

Sitka Sedge Dike Modification Planning Update



Town Hall meeting at the Kiawanda Community
Center in Pacific City, Oregon

November 15, 2024

3:00-4:30 PM

Meeting Purpose and Agenda

This meeting is being broadcast via Zoom webinar. The room has cameras and microphones in place to record meeting content from both the presenters and audience for the benefit of participants that cannot be here in person.

Meeting Purpose:

- ▶ To revive awareness and dialog after a year of hiatus due to lack of funding.
- ▶ To summarize the history and status of the project
- ▶ To discuss next steps
- ▶ To answer questions and receive comments

Meeting Agenda:

1. Panelist and project team introductions
2. Noel Bacheller - Summary of project history
3. Hunter White, ESA - Presentation of 30% preliminary designs for dike modification and setback dike construction
4. Chris Laity and Hunter White - Presentation of Tillamook County Public Works and ESA assessment of Sandlake Road Creek crossings
5. Questions/answers/public comments session

Dike Modification Investigation History



Town Hall Presentation
11/15/2024
Noel Bacheller, OPRD

Location and Setting

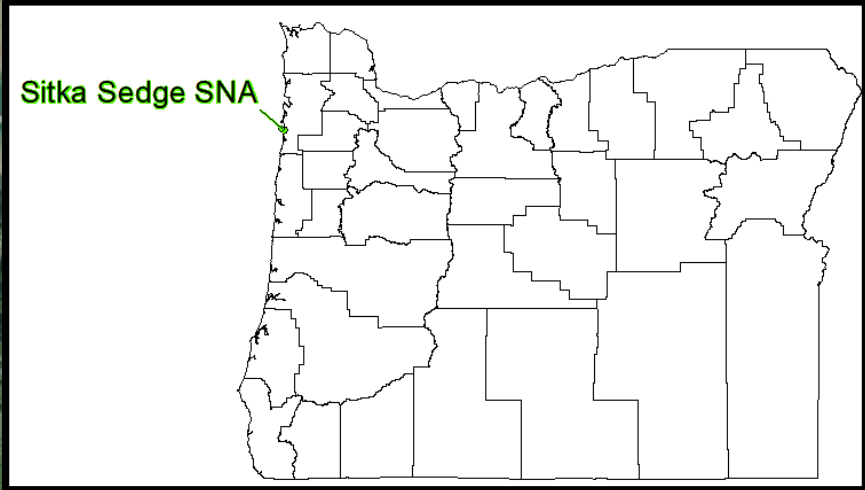

Source: Esri, DigitalGlobe, GeoEye, Earthstar Geographics, CNES/Airbus DS, USDA, USGS, AeroGRID, IGN, and the GIS User Community

Purpose and Need

- **Current tide gate is failing**
 - Boards on the flap are missing
 - The dike is eroded around the box culvert and wing walls
 - The box culvert itself appears to be compromised
 - The amount of work that would need to be done to repair and stabilize the existing gate would trigger fish passage regulations that would not allow the use of the current old-model structure
- **Current tide gate is undersized**
 - The 4' x 4' opening is insufficient to efficiently drain stormwater during major storms – resulting in backed up water inside the dike
 - “firehose” water velocity
- **Current tide gate restricts fish passage to Reneke, Beltz, and No-name Creeks as well as to the marsh behind the dike**
- **The current dike is only barely above current king tides and will soon be at risk of overtopping from sea-level rise**



What has been done so far?

Timing	Process
Sept 2014	Property acquisition
October 2014-June 2016	OPRD site and resource assessments: biological, cultural, recreation, scenic
June 2015-December 2016	Master planning for initial park opening and development
Oct 2015-June 2017	Initial hydrology studies
2016-2018	Groundwater and surface water monitoring and data collection
Sept 2017-June 2019	Detailed TDM groundwater effects investigation; Conceptual surface water refinements
Fall 2019	Technical team assessment of conceptual alternatives
February 2020	Presentation of findings to Tillamook County Commissioners and public
March 2020	OPRD decision to select the setback dike alternative for further investigation
2020-2022	TEP takes the lead on moving forward with designs. Grant applications by TEP to assess and preliminarily design setback dike refinements
Summer 2022	ESA begins detailed assessment of setback dike location concepts and Tierra Del Mar stormwater issues
Winter-Spring 2023	Conceptual design of refined alternatives and analysis of effects: setback dike locations, Tierra Del Mar stormwater system
June 2023	Presentation of consultant's preliminary work; northernmost setback dike location focus for continuing analysis
Spring 2024	ESA completed the SSTW 30% Plans and Basis of Design reports documenting 2023 work
Summer 2024	Coordination, scoping, and contracting final design and permitting phase, including geotechnical cost estimates

Public Involvement and Outreach

Meetings open to the public and advertised on the website and through mailing list

In all, at least 22 stakeholder meetings advertised and open to the public

Media

- ▶ news releases
- ▶ Website
- ▶ Email list release of notes and availability of materials on the website

Other

- ▶ Meetings with adjacent landowners
- ▶ Ongoing email collaboration and correspondence with TDM Community Association, interested landowners

Scenarios Compared in Assessments Completed Through the Years

No action/ existing condition – reference condition



Dike breach



Replace existing tide gate with modern muted tidal regulator– two 10' wide by 8ft' tall gates with 7', 8',9',10' closure setting



Setback dike- construct new dike closer to TDM that includes a modern tide gate, then breach the old dike... tide gate style/sizing/closure settings... location...



Existing

Modern Gate, 7 ft closure

Modern Gate, 8ft closure

Modern Gate, 9ft closure

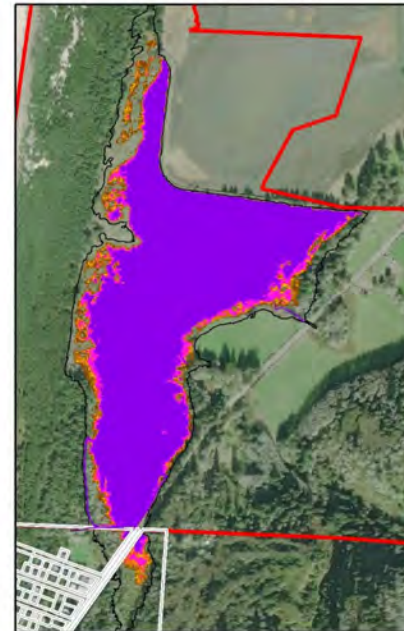
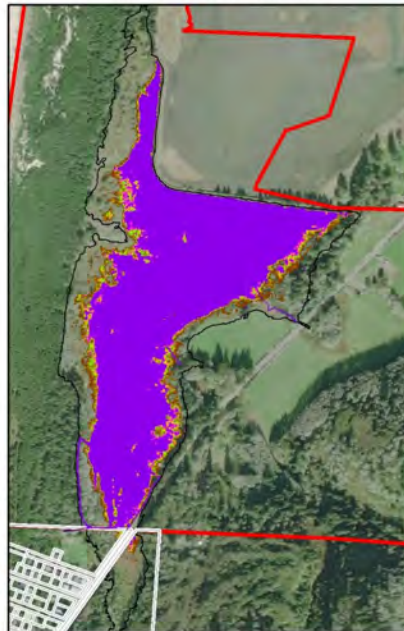
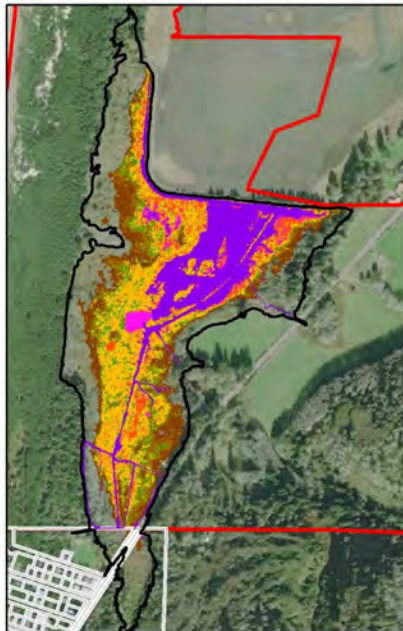
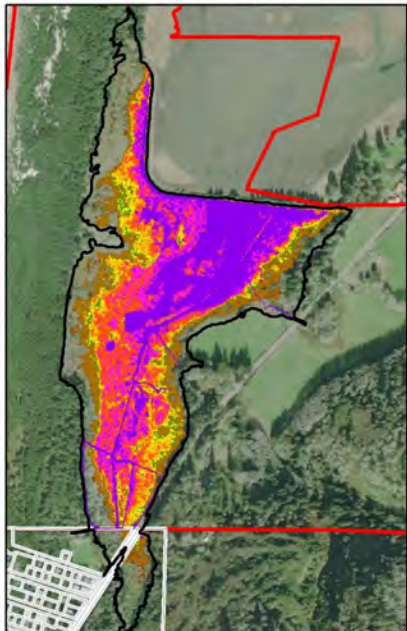

Modern Gate, 10ft closure

Breach

Setback dike, modern gate 7 ft closure

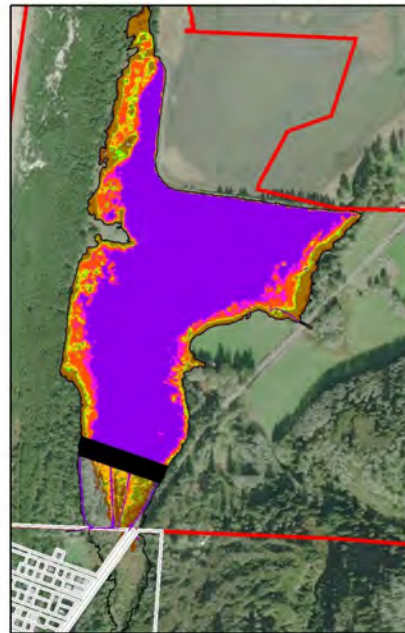
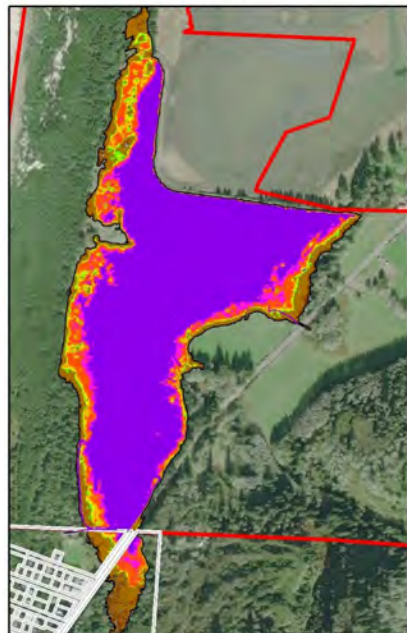
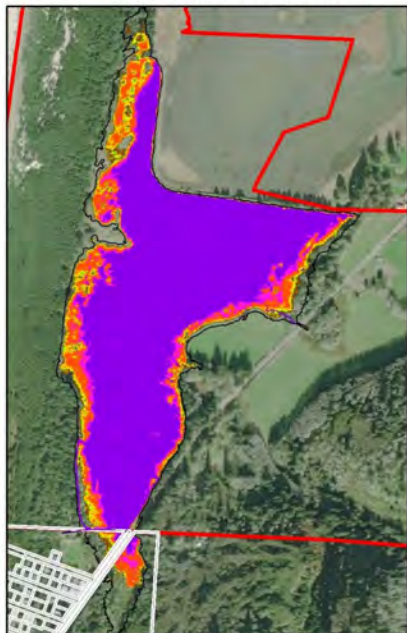

□ TDM taxlots

⊕ Sitka Sedge SNA Study Area

February frequency of inundation (days/month with some tide water)

■ 1 day

■ 2

■ 3

■ 4

■ 5

■ 5-10

■ 10-15

■ 15-20

■ 20+ days

2019 model. Just tides without a simulated storm event.

Extreme event conceptual model from 2019

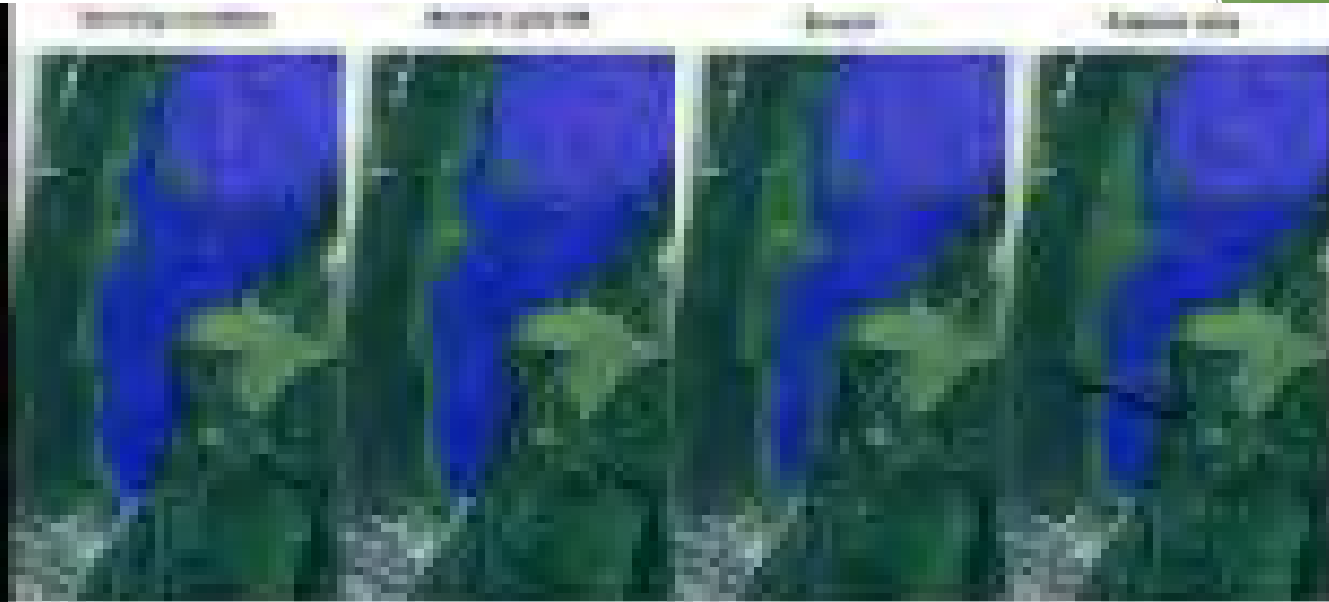

VIDEO SLIDE... Video link available on project website



OPRD Project Sideboards and Goals

1. The design should result in virtually no increase in tide water, stormwater, or elevated groundwater on private properties in Tierra Del Mar.
2. The design should result in meaningful improvements to estuary and fish habitats in the area inside the existing dike.
3. The design should restore fish passage to the mouths of Reneke and Beltz Creeks.
4. Recreational access across the marsh should allow visitors to see the marsh up close, reach the beach, and enjoy the diverse coastal environments in between.
5. The design should route Reneke Creek to the marsh naturally, rather than in an artificially constructed and channelized path near the parking area (that would enter the marsh on private property to the north), or along the roadside Sand Lake Road ditch to the south

Brief Summary Comparison of Options that Have Been Considered over the Life of the Project

1. No-action (leaving the dike and tide gate exactly how they are)

- Pros: none
- Cons: Least benefit and highest risk; dike will fail; existing dike is undersized and not to long term sustainable standards for sea level rise. Does not meet OPRD stated project goals.

2. Dike breach

- Pro: Highest estuary restoration value
- Cons: more frequent tidal effects to private properties than the other action-alternatives; Potentially lower protection from storm surge with sea level rise; Local public concern; Increased frequency of flooding on Sand Lake Road; Does not meet OPRD stated project goals.

3. Modern tidegates in the existing dike

- Pros: limits tide on private properties; lets stormwater out efficiently; improved fish passage
- Cons:

Dike not resilient to sea level rise. Current king tides reach top of dike low point already. Dike failure may become increasingly likely with increased sea levels or increased storm surge
Lower estuarine restoration and salmon benefits relative to breach and setback dike options
Existing dike is undersized. Building it up to install tide gates and increase height for sea level rise resiliency will result in very high cost - perhaps higher cost and more wetland fill than the setback dike option.

4. Setback dike

- Pros: Fish passage and rearing habitat benefits second only to those of the breach scenario. Higher protection to TDM than the existing dike. Resilient to sea level rise. Stormwater drainage from TDM comparable to Modern Tide Gate Scenarios. Requires much smaller and less expensive tide gate.
- Cons: Would be constructed through high value wetland habitat. Includes a mechanical tide gate structure that would require maintenance. Potential beaver issues. Expensive.

2020 Selection of the Setback Dike as the Alternative to Pursue

- In March 2020 - after the assessments and comparative ranking of alternatives by the Technical Team, public hearing with the Tillamook County Commission, and review by the Oregon Parks and Recreation Commission - OPRD leadership selected the setback dike alternative as the option to pursue for more detailed study and design.
- OPRD released a decision memorandum and a FAQ shortly thereafter
- OPRD received a letter of support for the setback dike alternative from the TDM community association in June 2020 to be used for the purposes of pursuing grants to continue the process

1. No-action
2. Dike breach
3. Modern tide gate in existing dike
4. New setback dike

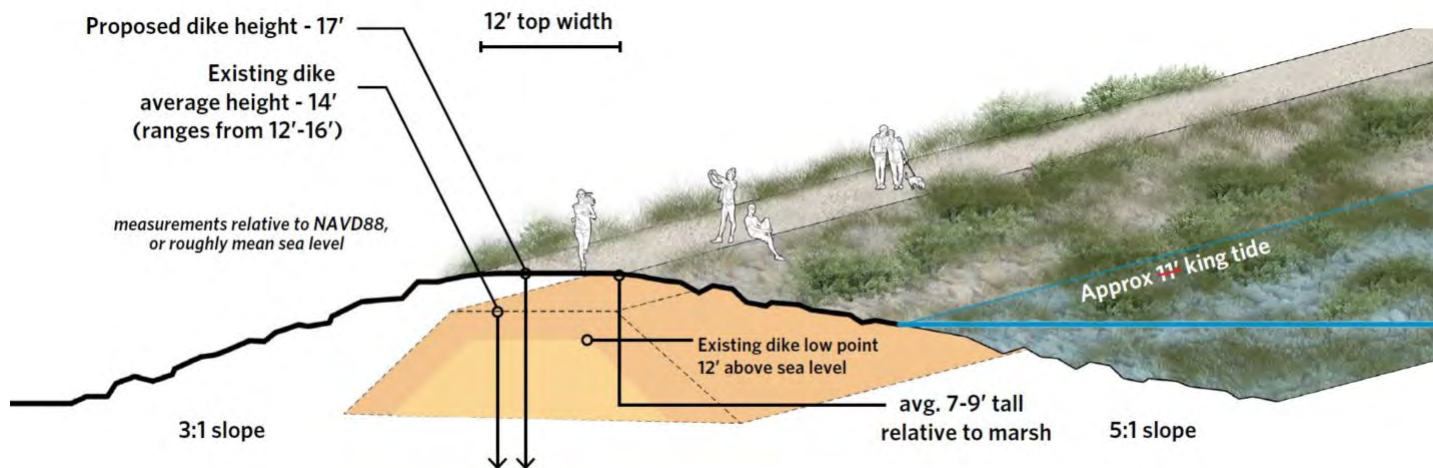

Further Study of the Setback Dike Alternative after 2020

Tillamook Estuaries Partnership and OPRD forged a relationship in 2020 to leverage TEP's expertise and experience in complex estuarine projects and stakeholder engagement

TEP has applied for and received grant funding to hire a consultant to pursue detailed designs

The current grant provides funding to continue to explore geotechnical aspects and advance design from 30% to 100%



Further Study of the Setback Dike Alternative in 2022-2023

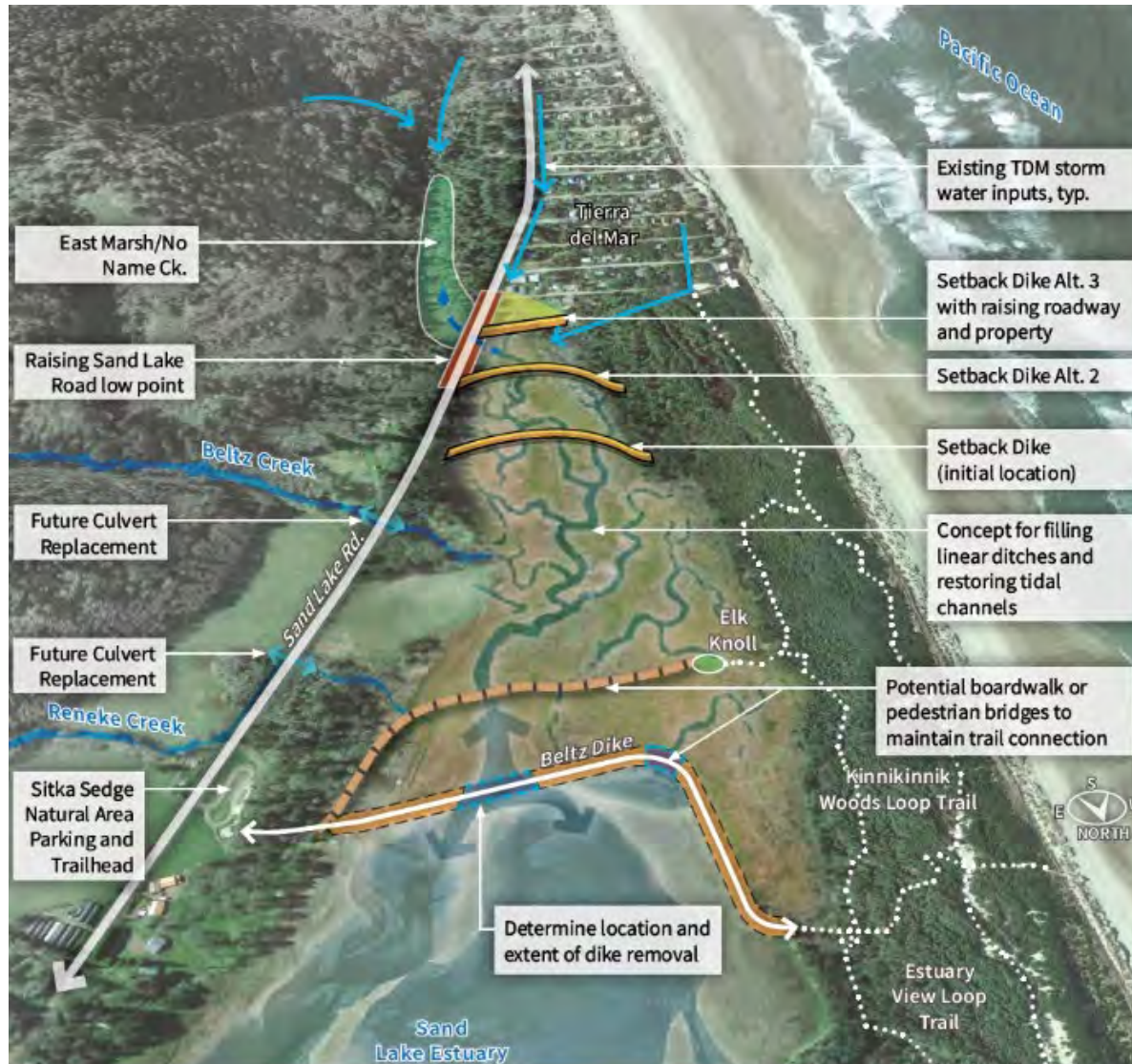

Also, Further Study of Tierra Del Mar Stormwater Drainage

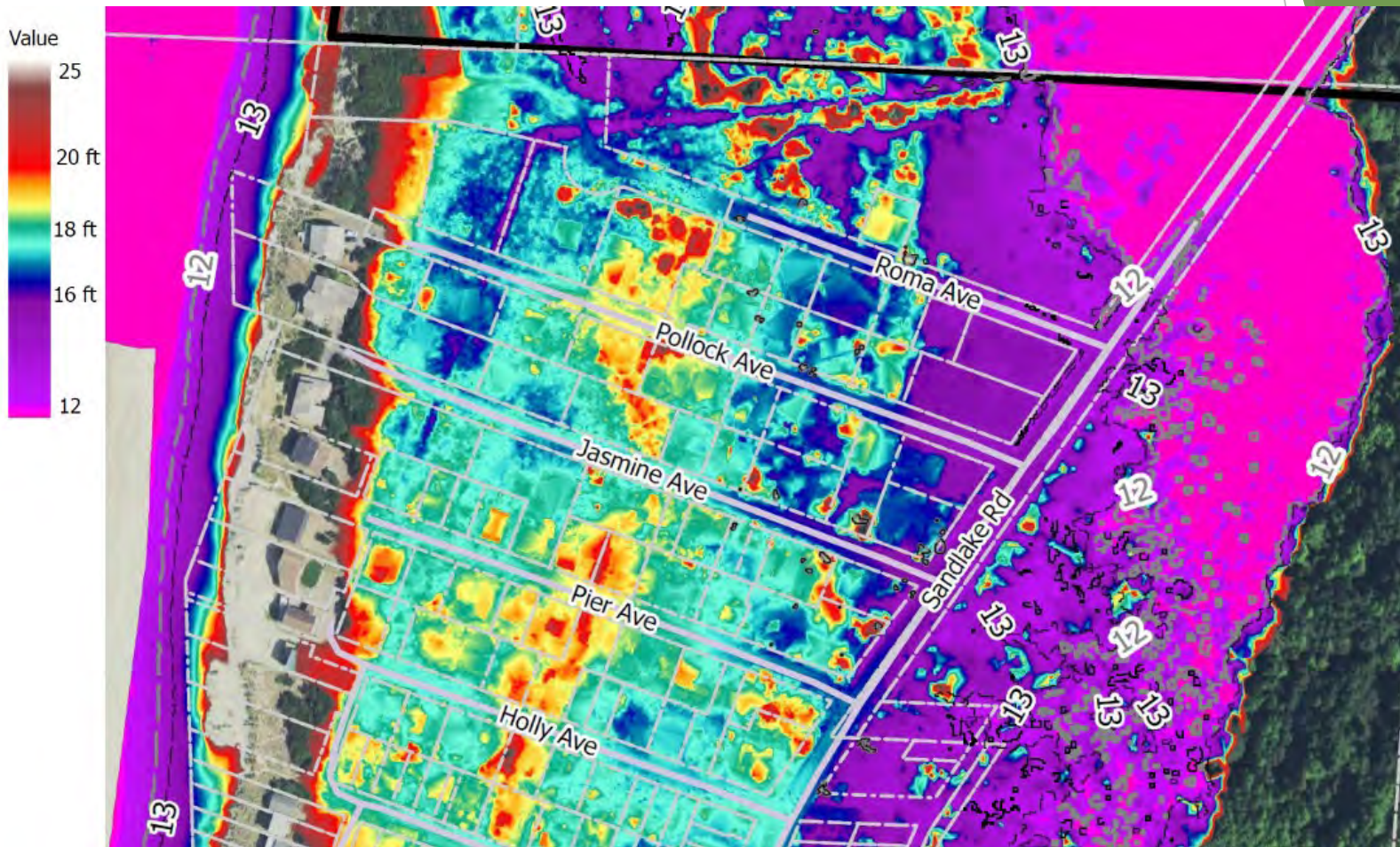

Setback dike location refinement: “tapping on the wall to find the stud”

Study involved exploratory trials of moving the potential location of the setback dike further and further back to try to find the sweet spot between:

- minimum footprint of the dike
and
- adequate storage basin for stormwater



The General Location of Alternative I Appears to be in the “Goldilocks Zone”



Alternative 1 is the only alternative that meets all of OPRD’s stated goals... but it is only a general location at this point and needs refinement and further investigation.

The goals that guide our work are:

- ✓ 1) The design should result in virtually no increase in tide water, stormwater, or elevated groundwater on private properties in Tierra Del Mar.
- ✓ 2) The design should result in meaningful improvements to estuary and fish habitats in the area inside the existing dike.
- ✓ 3) The design should restore fish passage to the mouths of Reneke and Beltz Creeks.
- ✓ 4) Recreational access across the marsh should allow visitors to see the marsh up close, reach the beach, and enjoy the diverse coastal environments in between.
- ✓ 5) The design should route Reneke Creek to the marsh naturally, rather than in an artificially constructed and channelized path near the parking area (that would enter the marsh on private property to the north), or along the roadside Sand Lake Road ditch to the south



Setback Dike Effects on habitat

- The footprint of the setback dike itself would result in fill of 1.5 acres of wetland habitat behind the current dike, which would be partially offset by removal of breached area(s) of the existing dike
- The project would restore approximately 70 acres of natural estuarine conditions and ecology relative to existing conditions
- Natural tide cycle and habitat would be restored in 78% of the land within the range of tides behind the existing dike, and 85% of the marsh within park boundaries.
- Higher tides north of the setback dike would provide fish and aquatic wildlife foraging and rearing habitat in areas previously not receiving tides and sea water, and this connection to new foraging habitat would be much more frequent in some areas that already receive muted tides.
- Full fish passage would be restored to the mouths of Beltz and Reneke Creeks
- Sediment accretion in the restored natural estuarine conditions north of the setback dike would increase likelihood of keeping pace with sea level rise.

Effects on habitat

Aside from hydrology and physical footprint, habitat composition shifts are expected due to altered hydrological niches of vegetation types

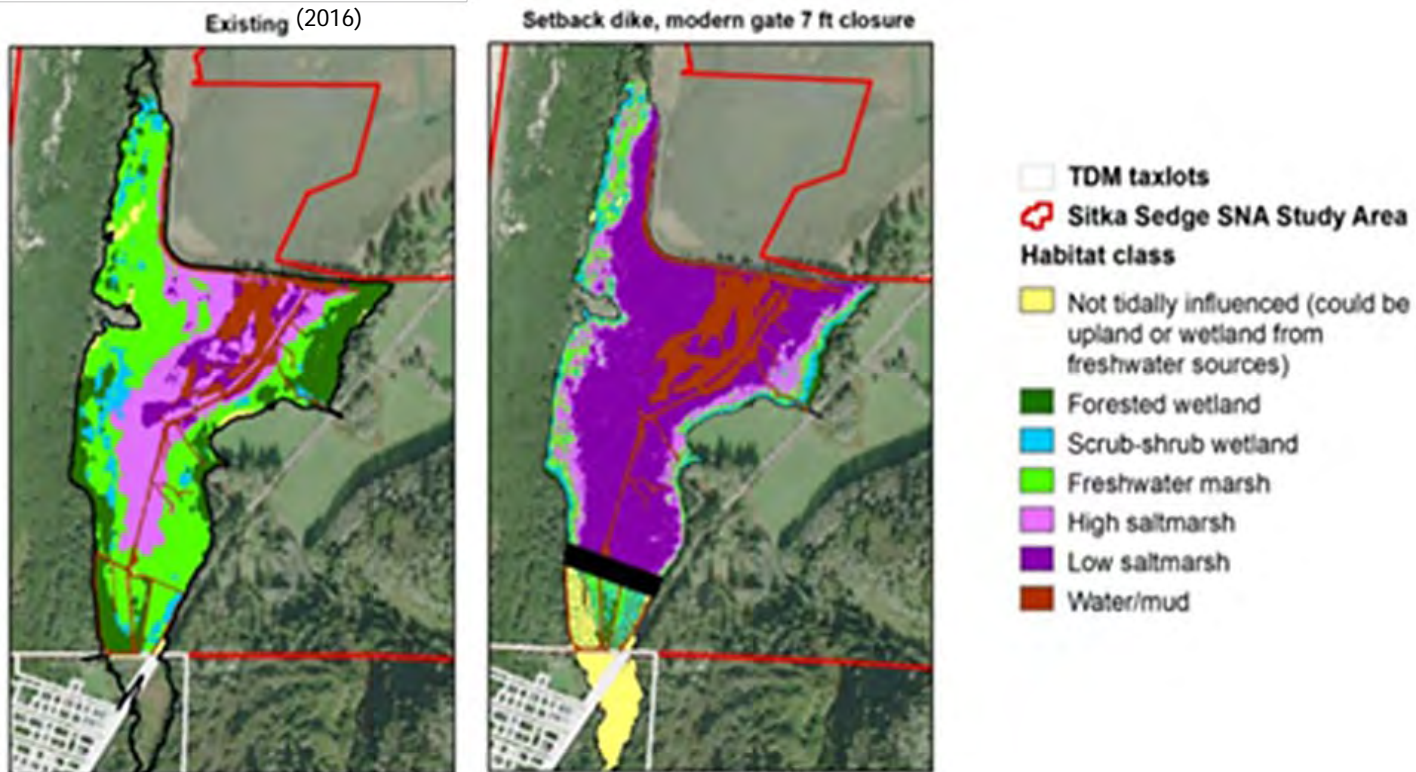

Note: vegetation data was not recorded outside of the park in 2016. This figure shows no habitat values outside of park property.

2019 modeling

Effects on habitat... hydrology-driven vegetation type shifts



	Existing dike	Setback (7ft closure)
Mud/water	6.8	9.6
Low saltmarsh	4.6	40.2
High saltmarsh	17.5	10.1
Freshwater marsh	29.5	6.5
Scrub-shrub	5.2	5.3
Forested wetland	15.4	4.3
Not tidally influenced	2.9	5.2
	81.9	81.2

Effects on habitat... physical footprint of the setback dike

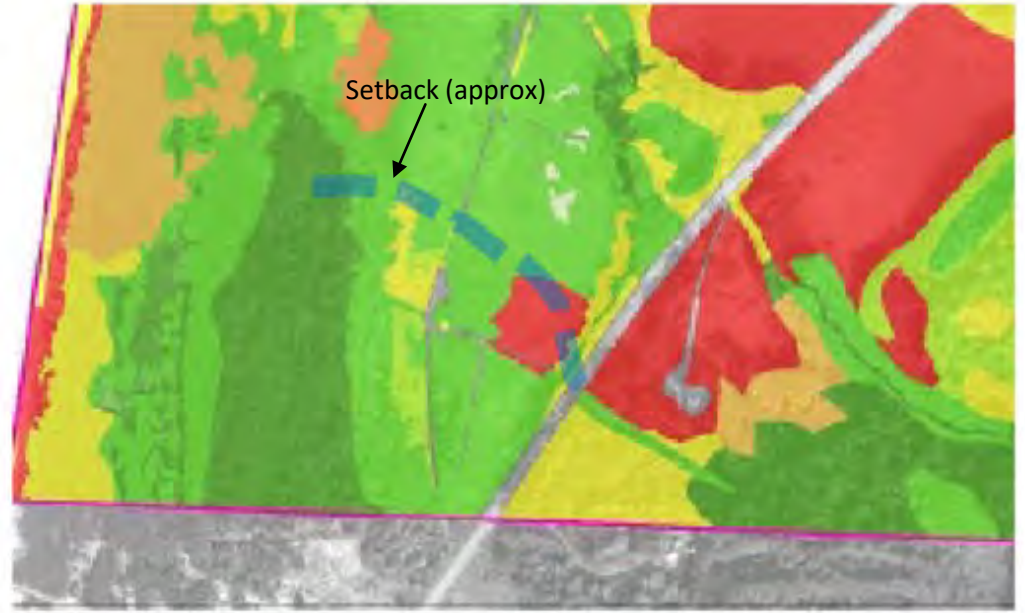
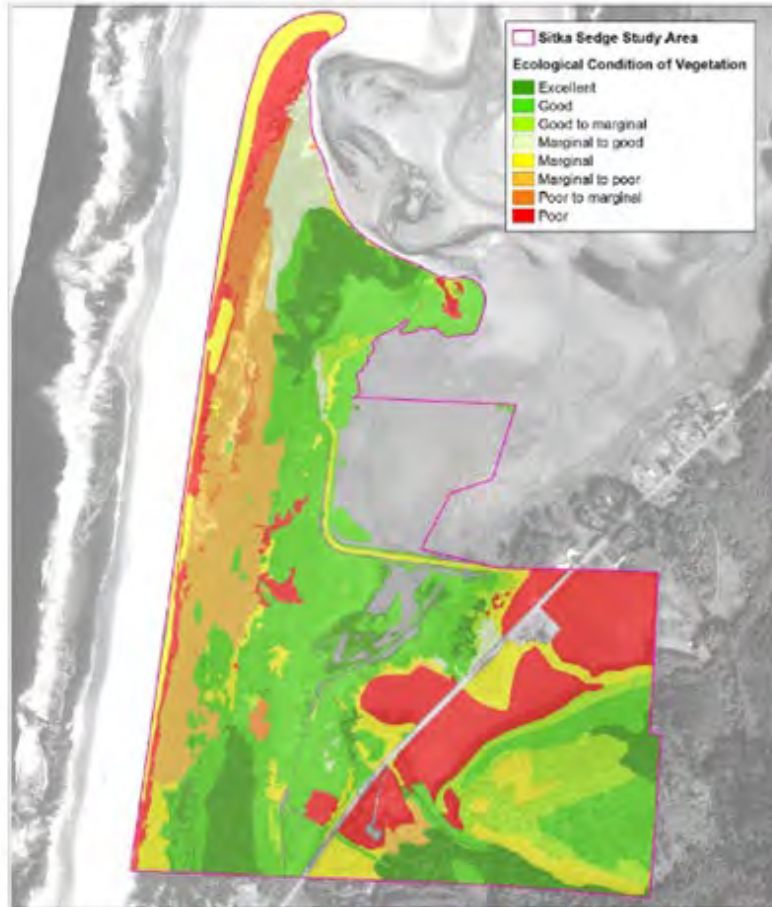

Effects on private property and public infrastructure

- The setback dike would block tides over the height of the tide gate closure setting from intruding onto private property
- The setback dike is taller than existing dike - giving several feet of resilience against sea level rise. The current dike is within inches of overtopping with current sea levels
- A setback dike would reduce groundwater elevation in properties adjacent to the park during major storm events
- Dramatically improves stormwater drainage from private properties adjacent to the park relative to existing conditions
- Sand Lake Road would be protected from flooding to allow continued usage of the road during major storms. Sand Lake Road currently overtops during extreme high stormwater flow events, and would overtop more frequently without modifications in the event of existing dike failure or overtopping due to elevated sea levels.

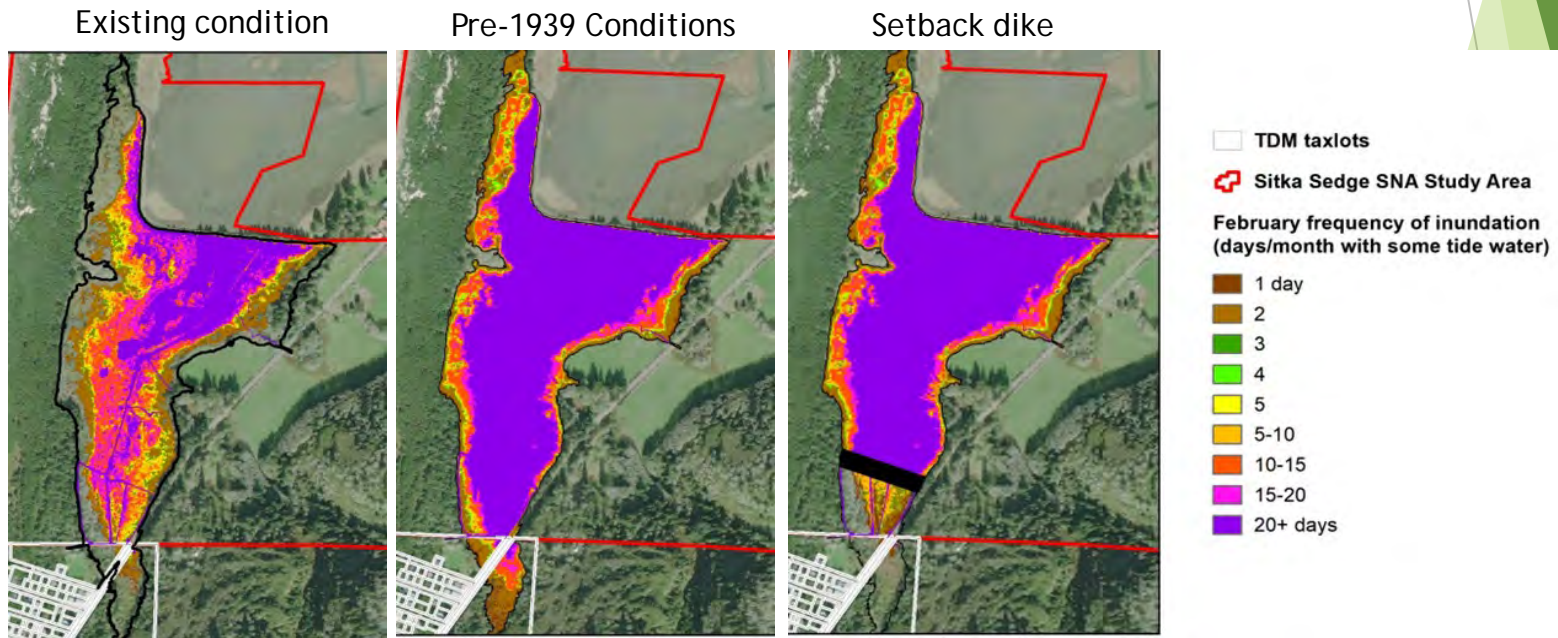

Mitigation for fill from the setback dike

- Breaching the existing dike will result in re-wetting of a band of elevation that is above the range of the currently muted tides.
- 50% Exceedance is a frequently used boundary for estuary extent, and has been determined through Pacific Marine and Estuarine Fish Habitat Partnership work to be at approximately 12 feet in the Sand Lake estuary.
- Muted tides inside the existing dike are approximately 1.5' lower than those outside of the dike under circumstances without extreme stormwater flows
- The band of increased tidal reach is depicted here in green and amounts to 5.6 acres of rewetted estuary.
- The current estimate of setback dike footprint is 1.5 acres, so estuarine creation is more than 3.7 times the area of the new fill.
- Further compensation could also be available in the dimensions of the breach of the existing dike, or through partial dike removal.
- This mapping is preliminary and would need to be adjusted for more precise estimates of current muting of tides

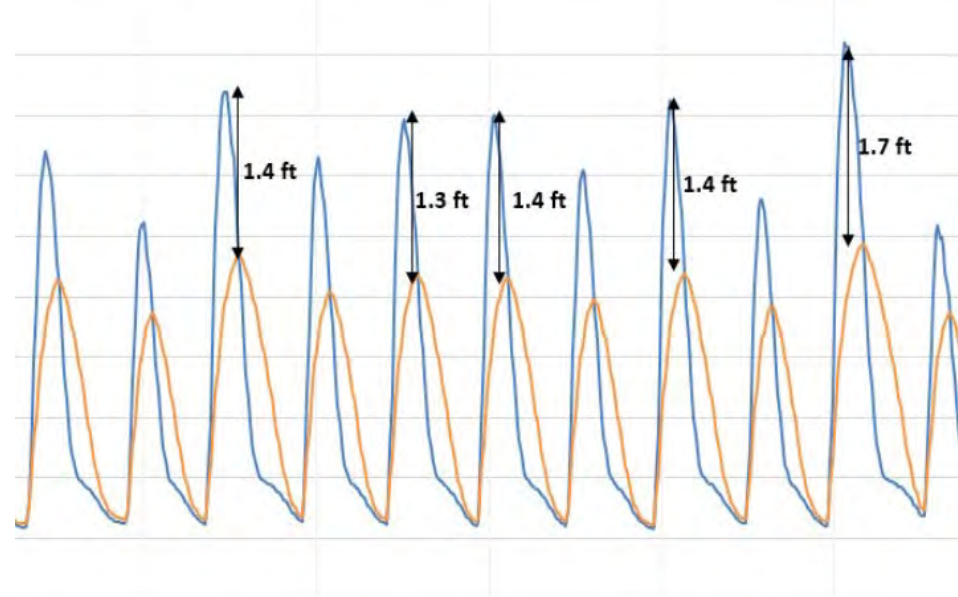

Next Steps

- Geotechnical assessment of technical constructability and design considerations that will drive cost, timeline.
- Continued design from 30-100% according to findings of Geotech and other analyses
- Permitability - Investigate regulatory situation in more depth
- New grants:
 - TEP has received a NOAA grant to conduct geotechnical work and resume design using the geotechnical findings (up to 100% design).
 - New grants will be needed for the construction phase

Sitka Sedge Tidal Wetland Restoration: Town Hall Meeting – 30% Design Project Update



November 15, 2024

Hunter White, P.E. – Principal Civil and Water Resources Engineer – ESA



**TILLAMOOK
ESTUARIES
PARTNERSHIP**



Sitka Sedge Tidal Wetland Restoration 30% Design Update

- Following Alternatives Analysis presented in Fall 2023, ESA completed 30% Design for Sitka Sedge Tidal Wetland Restoration
- 30% Design includes:
 - Single Dike Breach with Pedestrian Bridge to maintain trail access
 - Setback Dike north of existing main beaver dam (Setback Dike Alternative 1)
 - Drainage Structure/Tide Gate system at setback dike to prevent peak tides and drain runoff from TDM and East Marsh watershed
- ESA and team of subconsultants recently entered into new contract to advance the project to final design and permitting

Sitka Sedge Tidal Wetland Restoration 30% Design Update

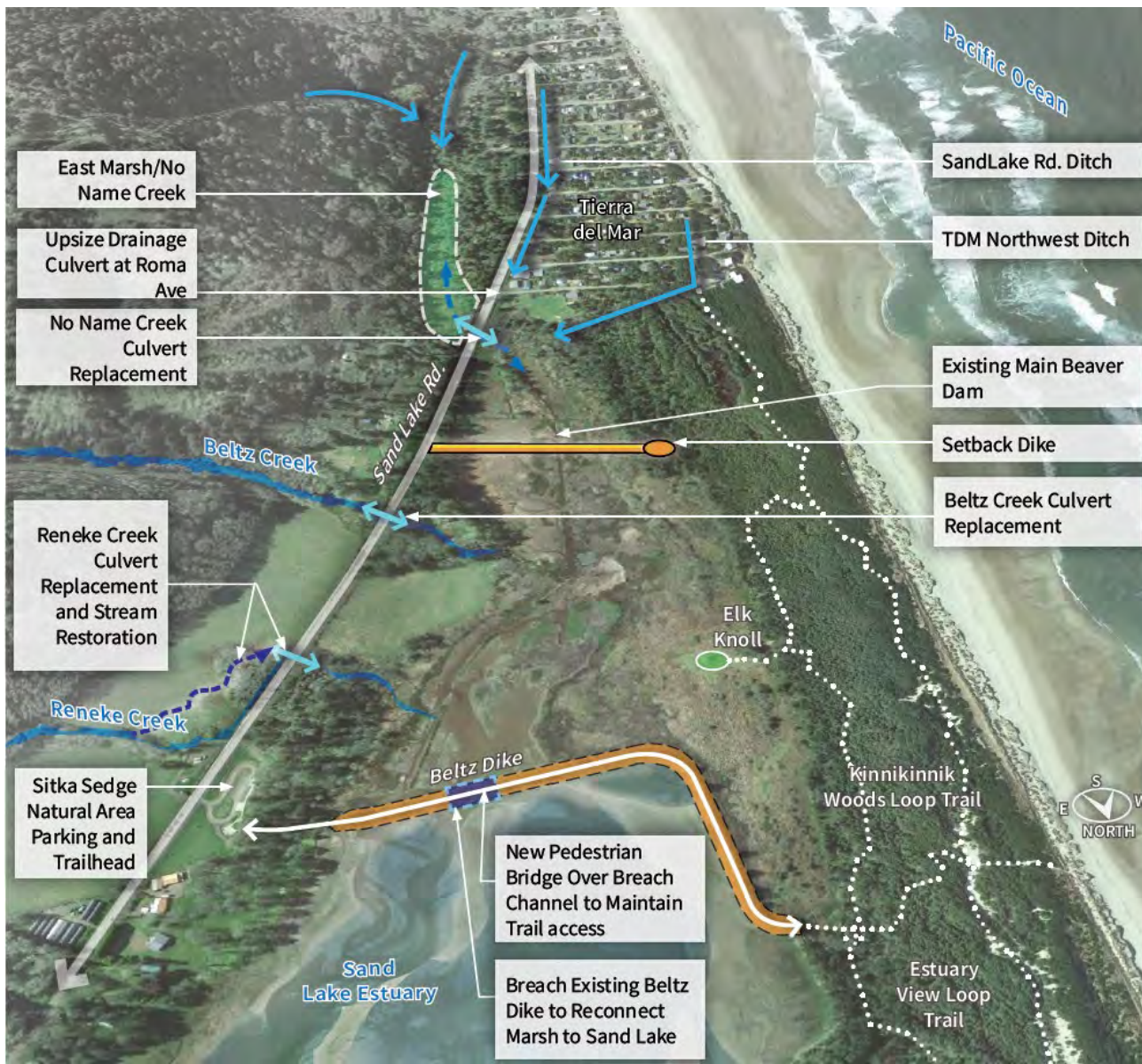

Sitka Sedge Tidal Wetland Restoration 30% Design Update

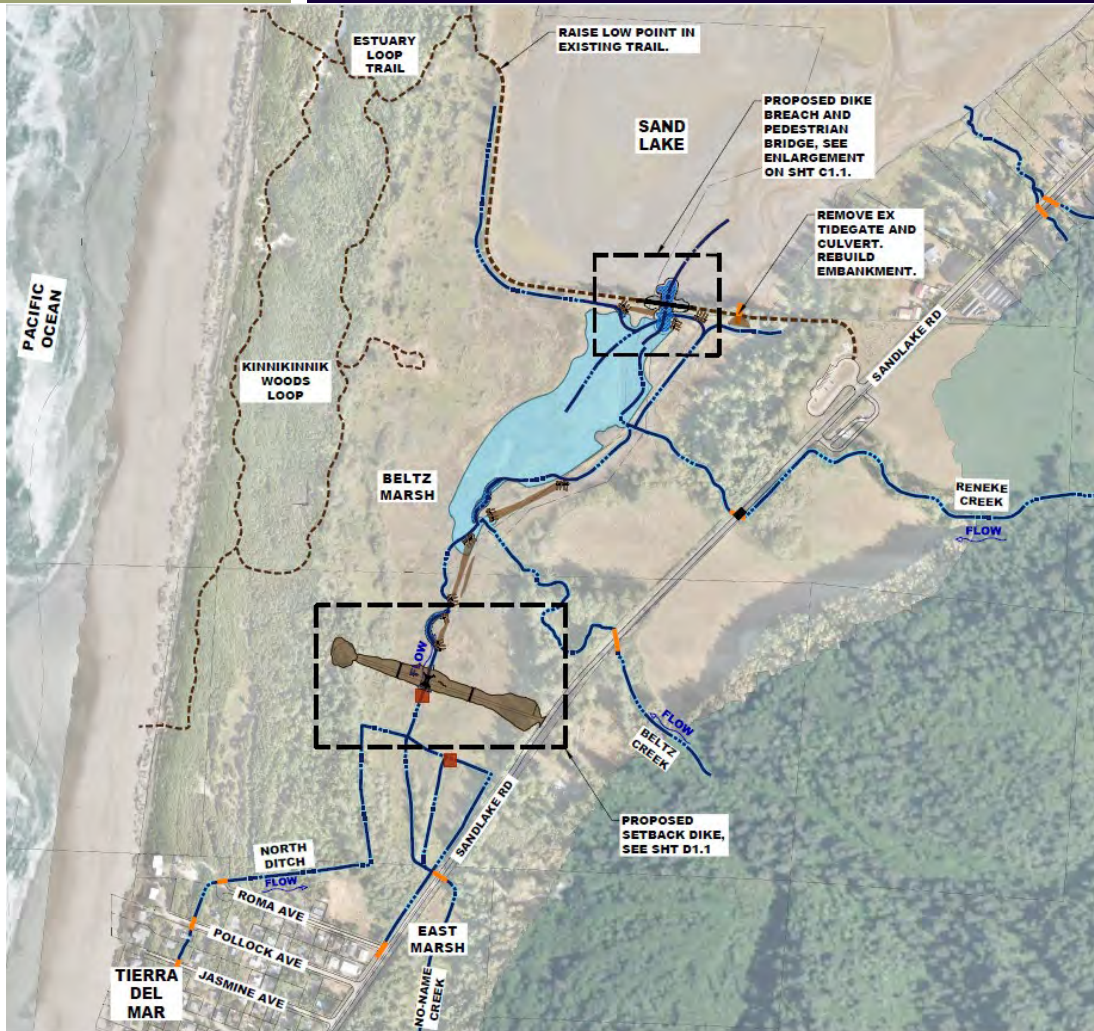

- Single Dike Breach with Pedestrian Bridge to maintain trail access
- Setback Dike (Alternative 1) north of main beaver dam with storage capacity for stormwater runoff from TDM
- Interior Enhancements
 - Tidal channels, ditch filling, large wood, vegetation/habitat enhancements

Dike Breach and Ped Bridge

- 30% Plans currently show a 200-foot dike breach and pedestrian bridge to be refined
- Bridge and breach design to be refined through coordination with OPRD and bridge engineer, and site-specific data analysis
- Depending on permitting requirements may still consider boardwalk option

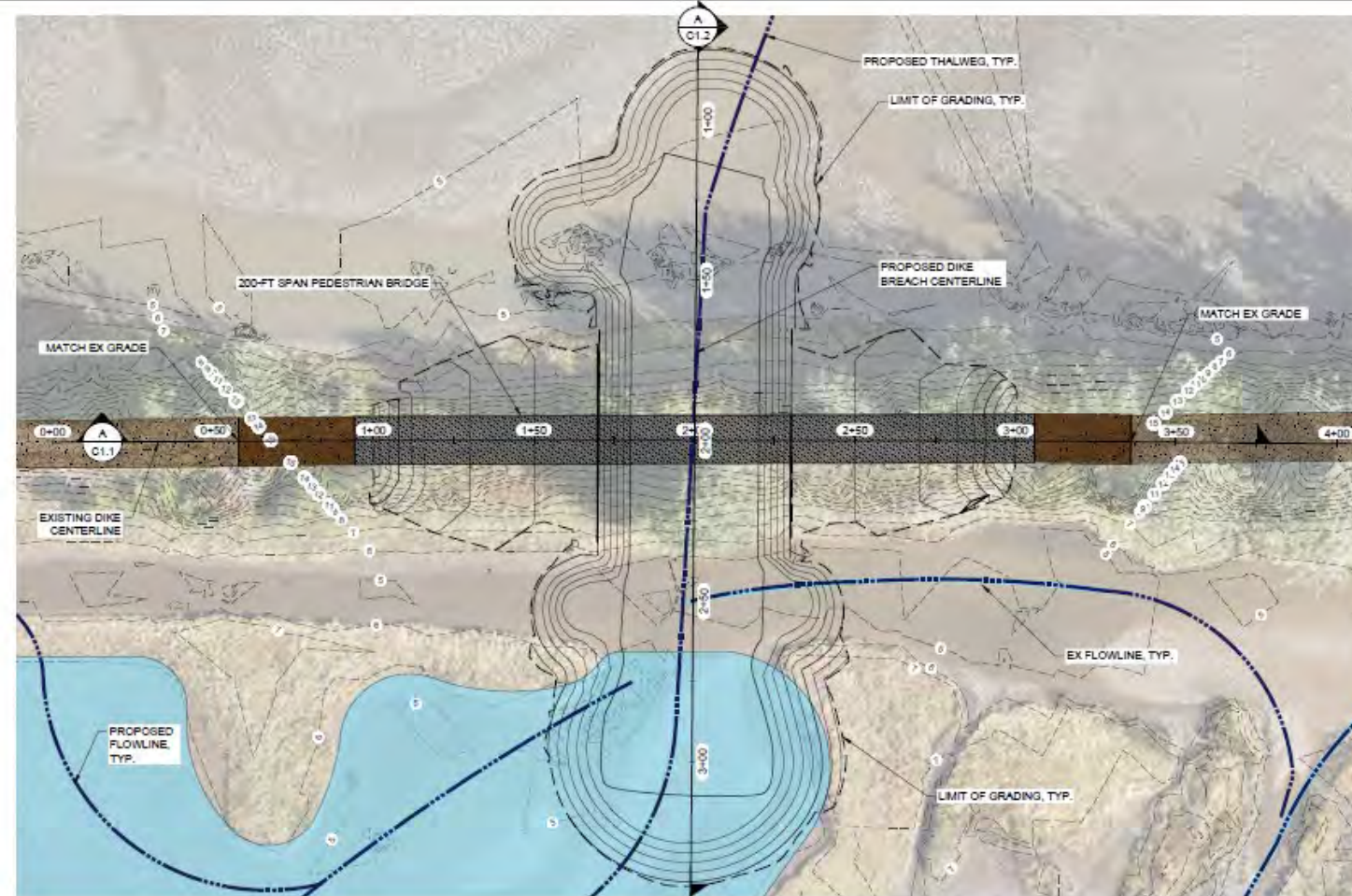

DIKE BREACH PLAN
SCALE: 1" = 20'

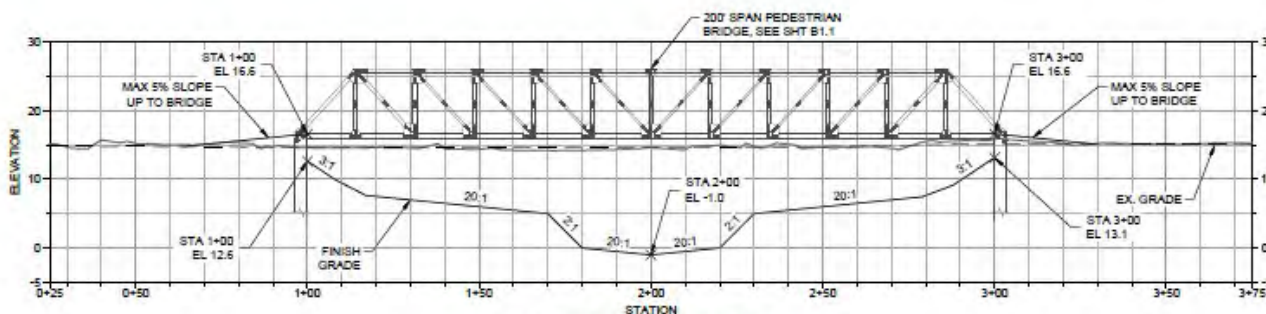
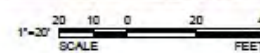

DIKE BREACH SECTION
PROFILE
HORIZONTAL SCALE: 1" = 20'
VERTICAL SCALE: 1" = 10'

Prefabricated Pedestrian Bridge Examples



Proposed Setback Dike Design

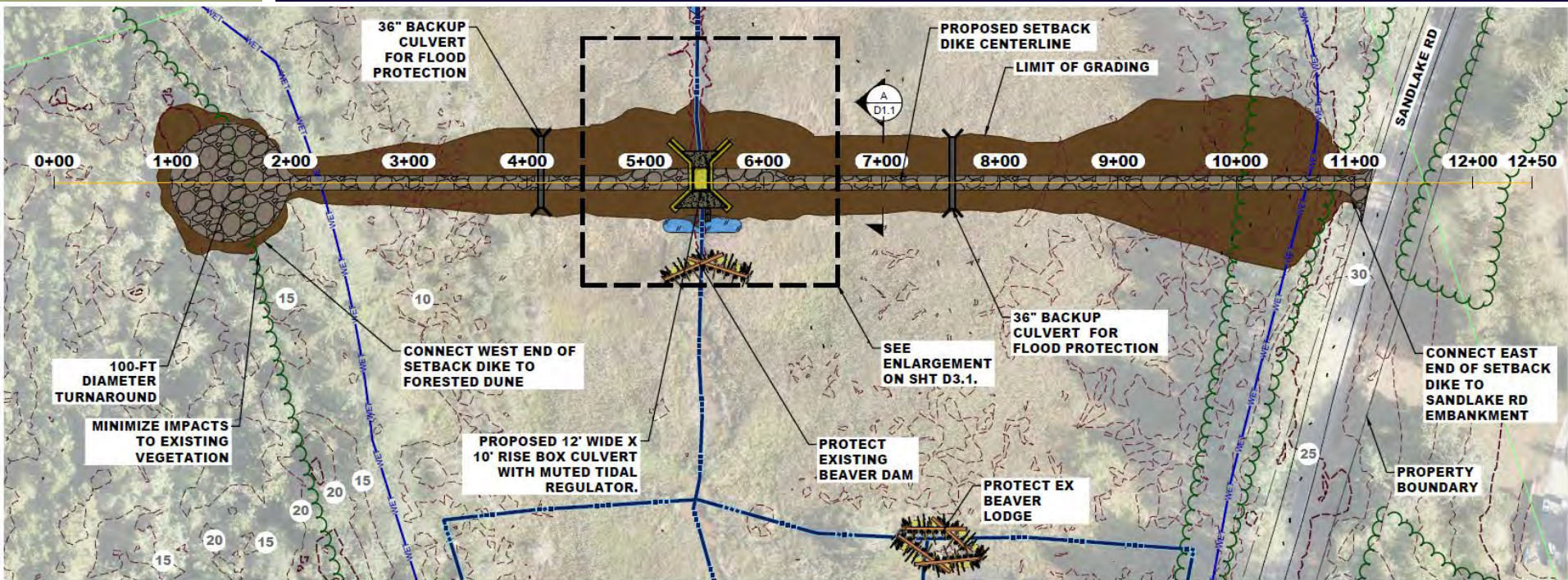

SETBACK DIKE PLAN
PLAN SCALE: 1" = 50'

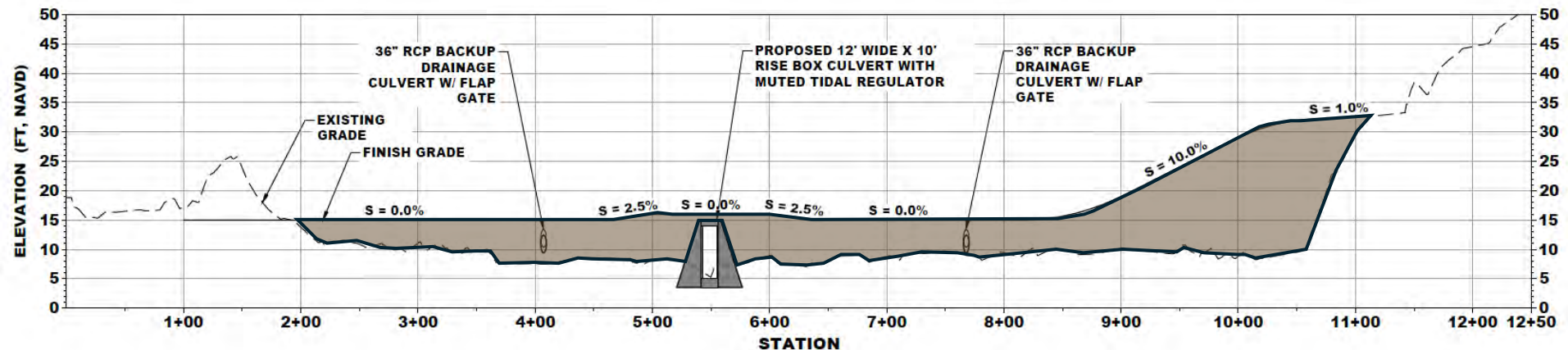
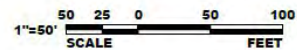

SETBACK DIKE PROFILE
PROFILE HORIZONTAL SCALE: 1" = 50'
VERTICAL SCALE: 1" = 10'

Proposed Setback Dike Design Geotechnical/Settlement Considerations

Likely will build over at least 2 years and overbuild height to account for settlement

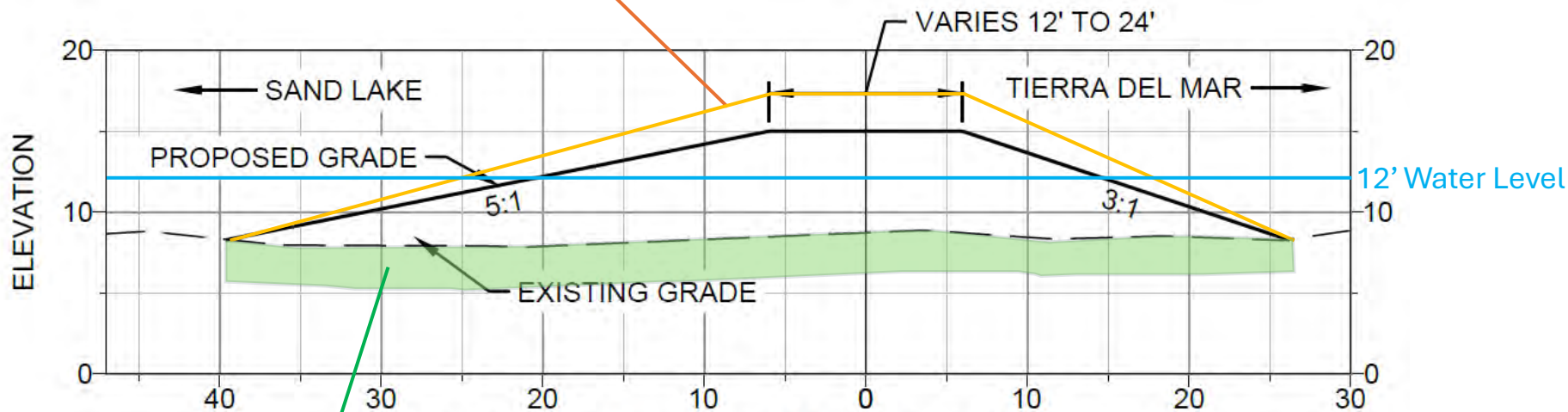

SETBACK DIKE TYPICAL SECTION

SECTION

HORIZONTAL SCALE: 1" = 10'

VERTICAL SCALE: 1" = 10'

Surface preparation likely includes removal of soft soils and subgrade stabilization measures

Proposed Setback Dike Design Drainage Structure and Tide Gate

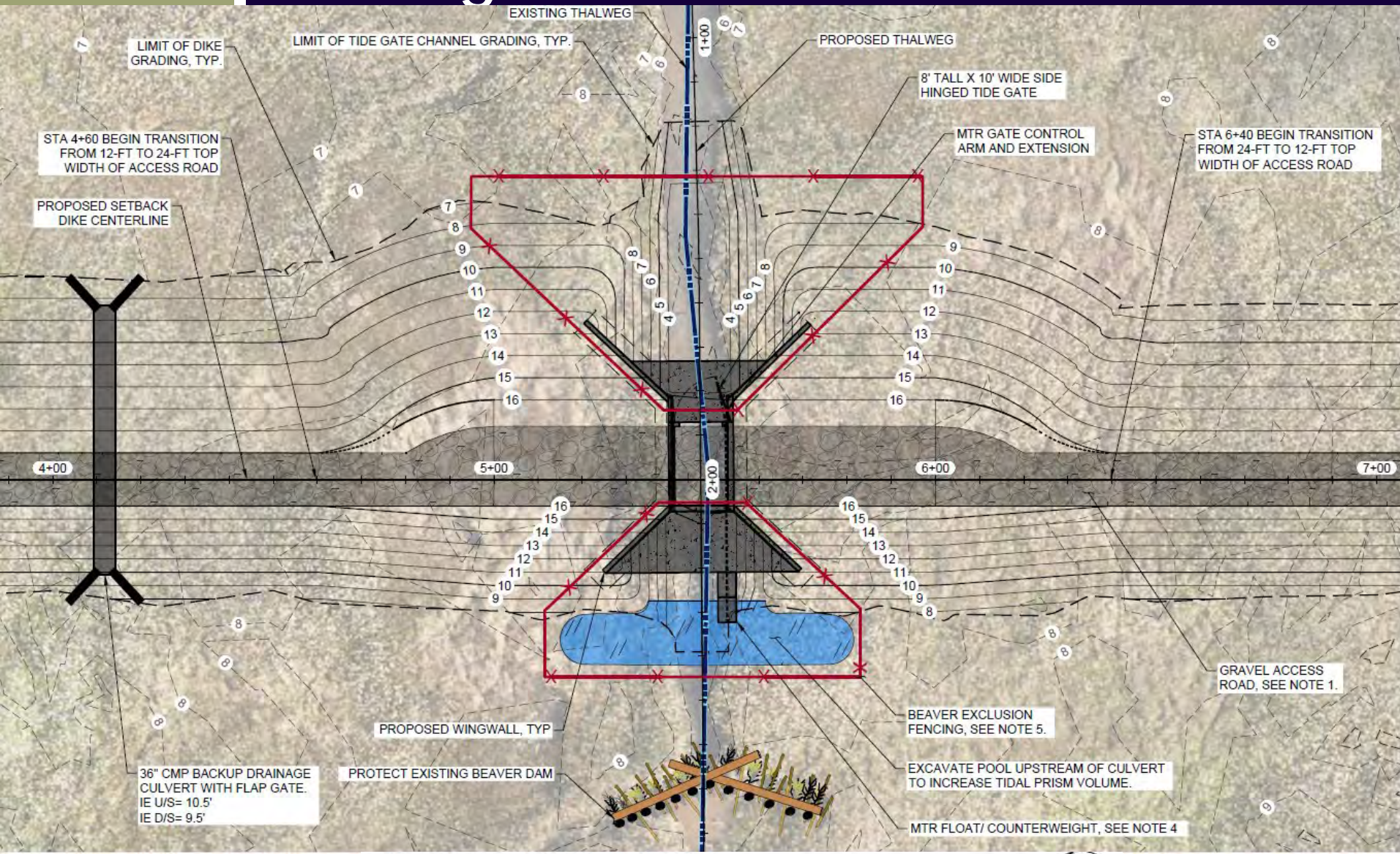

TIDE GATE GRADING PLAN ENLARGEMENT

PLAN

SCALE: 1" = 16'

1" = 16'



Proposed Setback Dike Design Drainage Structure and Tide Gate

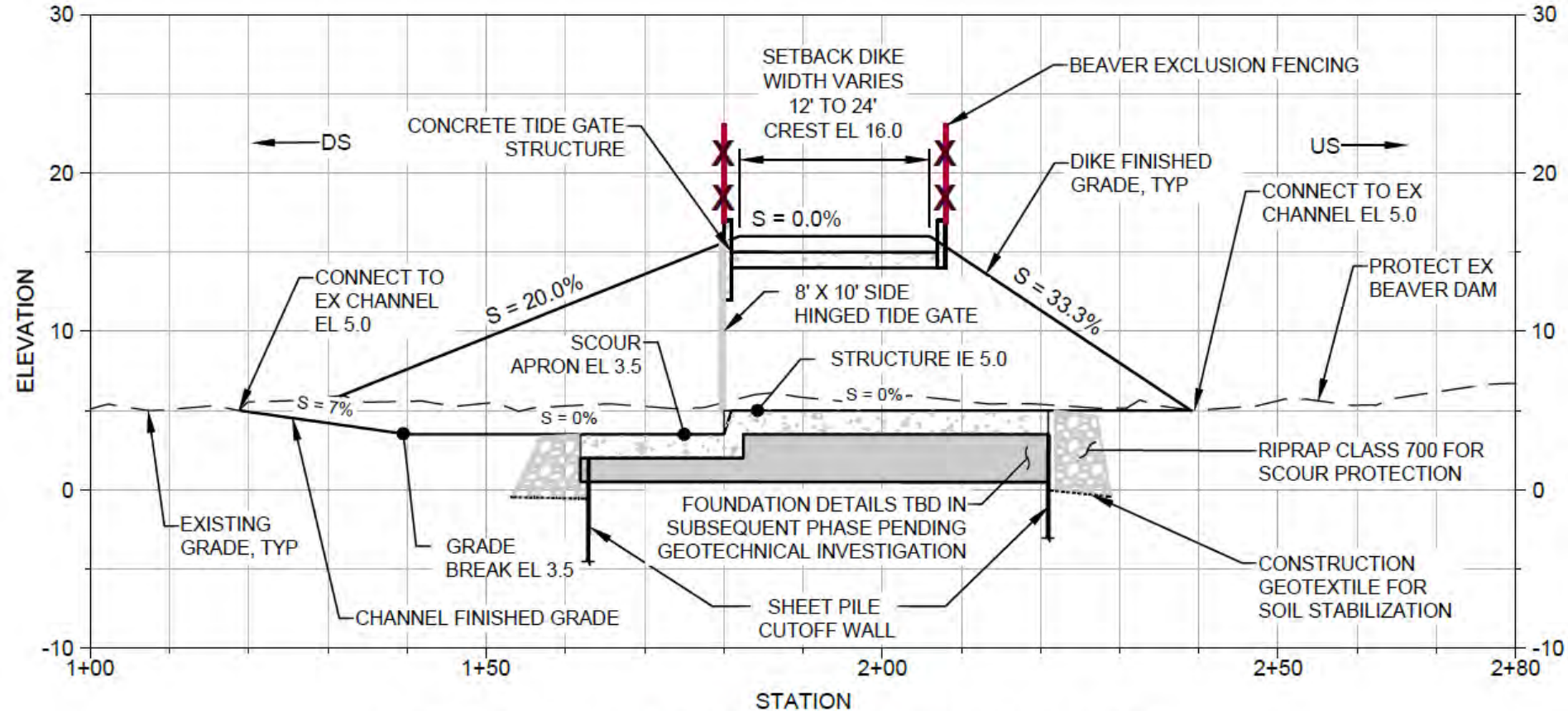

1 TIDE GATE CONNECTION CHANNEL PROFILE
 --- PROFILE
 HORIZONTAL SCALE: 1" = 16'
 VERTICAL SCALE: 1" = 8'

Proposed Setback Dike Design Drainage Structure and Tide Gate

- Tide Gate Structure Foundation to be designed based on geotechnical and structural engineering
 - Determining soil and bedrock conditions below ground

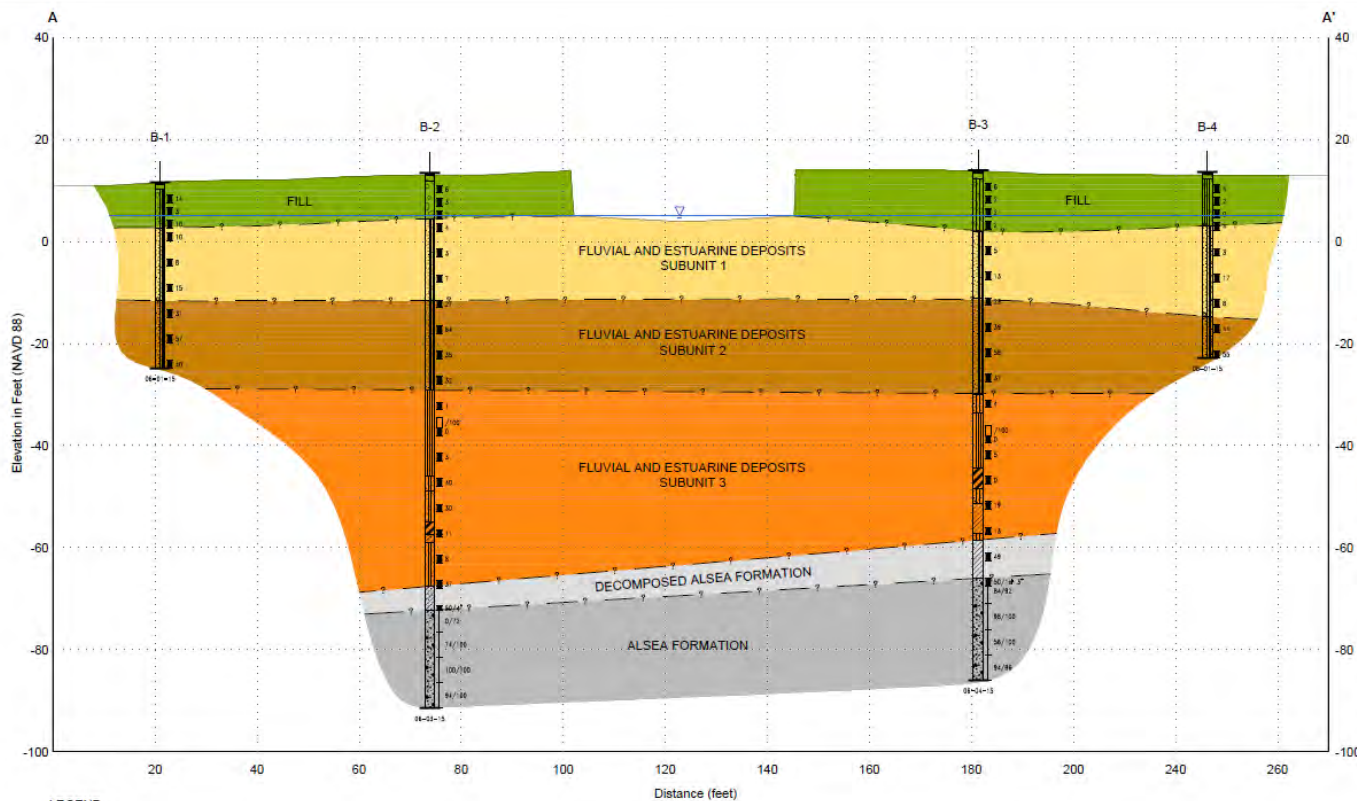

Long-term Beaver Influence on Setback Dike, Culvert, and Tide Gate

- **Beavers will likely remain at Sitka Sedge after reconnection**
 - **Likely to maintain blockages in channel network upstream and downstream of setback dike**
- **How will beavers behave around new setback dike's culvert and tide gate?**
 - **Beavers plug culverts when able and beneficial for their habitat (create ponded area)**
- **Drainage and flooding implications**
- **Maintenance implications**

Beaver Deceiver/Exclusion devices



Skip Lisle, Beaver Deceivers International
<https://beaverdeceivers.com/the-beaver-deceiver/>

Interior Marsh Enhancements, constraints, impacts, tradeoffs (ditch fill, new channels, large wood)

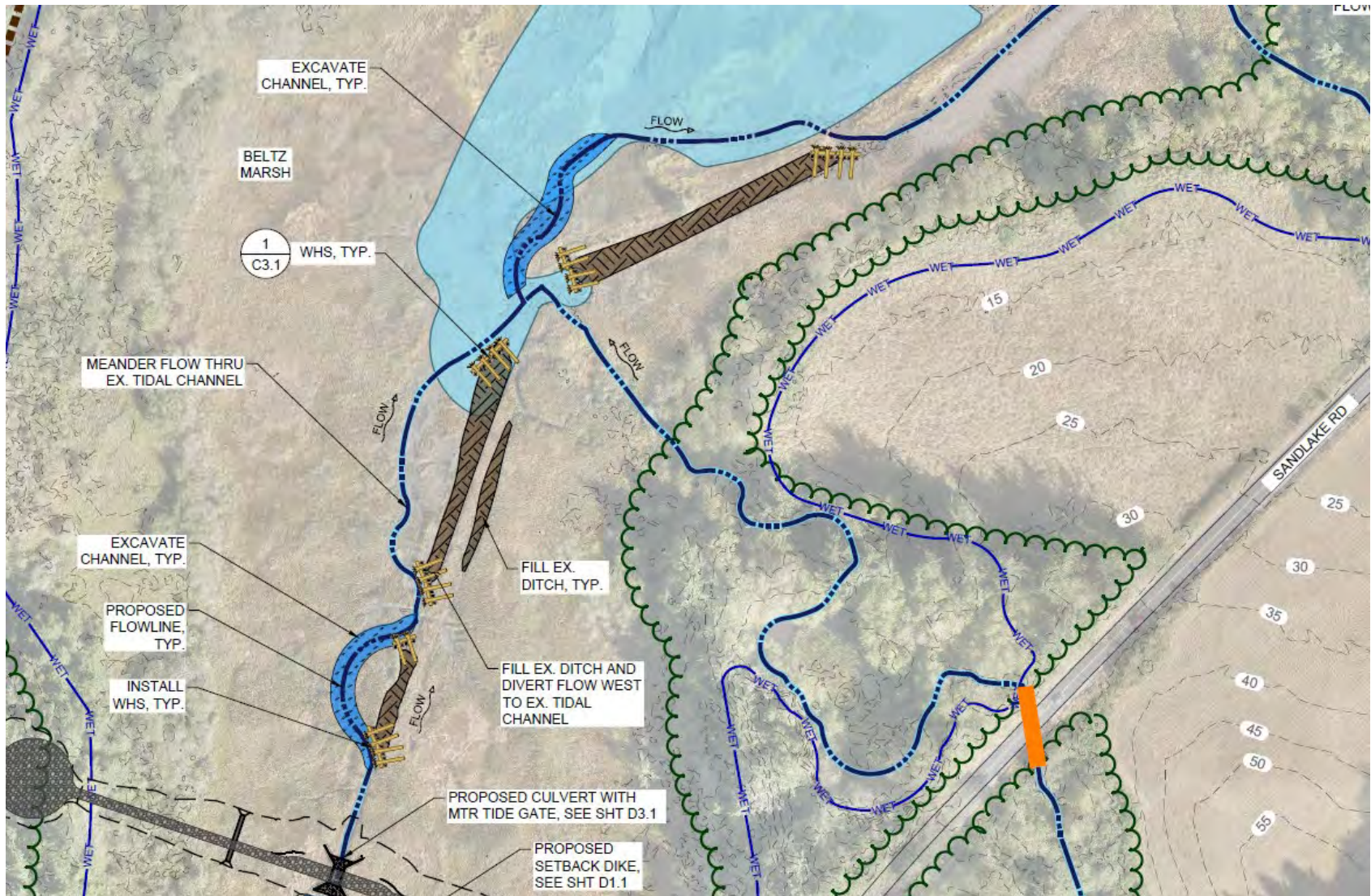

Roma Ave Culvert Inlet and Outlet



Roma Ave



Upsize Roma Ave Culvert (bottleneck at downstream end of Sandlake Rd Ditch)

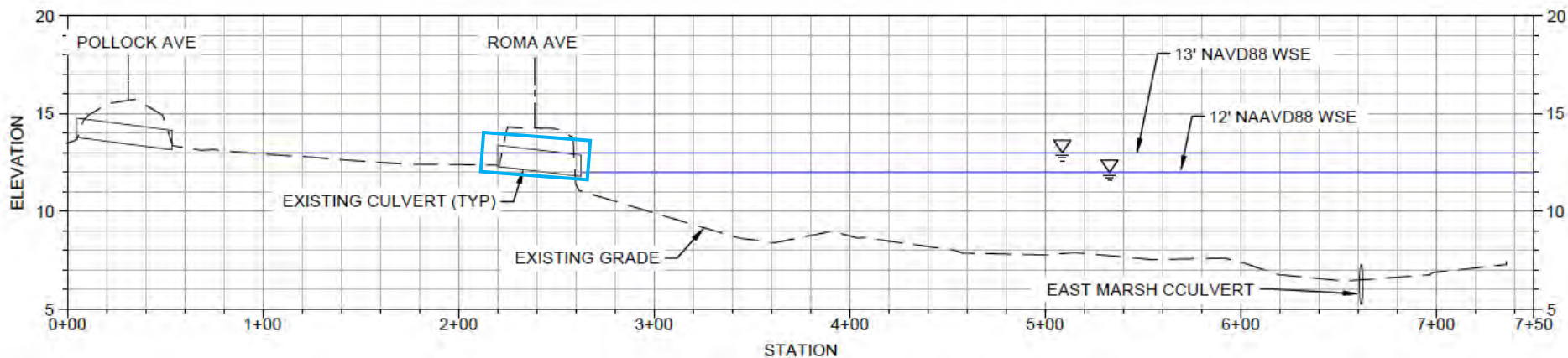

30% Engineer's Opinion of Probable Construction Cost – SSTW

Sitka Sedge Tidal Wetland Restoration

30% DESIGN - ENGINEER'S OPINION OF PROBABLE CONSTRUCTION COST

Categorized Summary of Estimated Construction Costs

<i>Item Description</i>	<i>Item Cost</i>
Mobilization/Demobilization	\$ 461,700
Access, Traffic Control, Water Management	\$ 763,500
Demo, Clearing and Grubbing	\$ 45,000
Dike Breach and Channel Excavation	\$ 357,500
Prefabricated Pedestrian Bridge and Foundations	\$ 960,000
Setback Dike Embankment and Imported Fill	\$ 1,550,000
Setback Dike Drainage Structure, Tide Gate, MTR	\$ 678,500
Backup Drainage Culverts and Flap Gates	\$ 62,000
Upsize Roma Ave/Sandlake Rd Ditch Culvert	\$ 12,500
Setback Dike Access Road	\$ 49,003
Seeding and Stabilization	\$ 49,000
Wood Habitat Structures	\$ 90,000
30% Contingency for early design stage	\$ 1,523,611
Estimated Total Construction Cost	\$ 6,602,314

Sandlake Road Culvert Crossings

- Reneke Creek
- Beltz Creek
- No Name Creek / East Marsh

Chris Laity, P.E. – Public Works Director and County Engineer
Tillamook County Public Works

ESA – hydraulic and geomorphic analysis, stream restoration design
David Evans and Associates – roadway and bridge design



Beltz Creek and No Name Creek/ Sandlake Road Culvert Replacements funded to 30% Design in this phase

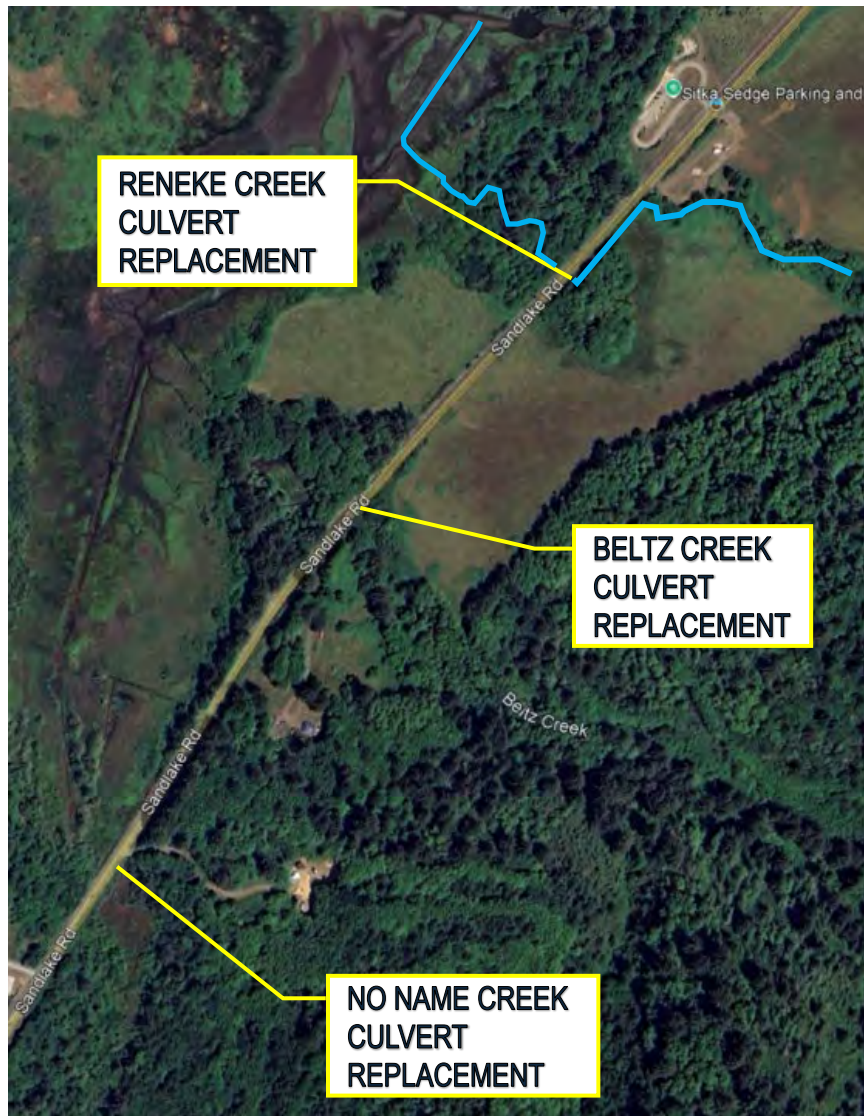

- Reneke Creek/Sandlake Road Culvert Replacement – Type, Size, and Location and 30% Design completed in Spring 2024 by ESA and DEA under separate contract with Tillamook County Public Works (TCPW)
- Reneke Creek design now being combined with Sitka Sedge project for Final Design and permitting – Partnership with TCPW, TEP, OPRD, and Salmon SuperHwy
- Beltz Creek and No Name Creek culvert replacements through 30% Design also included, pending funding for final designs

Reneke Creek Culvert Replacement - 30% Design for Tillamook County Public Works



Chris Laity, P.E. – Public Works Director and County Engineer
Tillamook County Public Works

ESA – hydraulic and geomorphic analysis, stream restoration design
David Evans and Associates – roadway and bridge design



DAVID EVANS
AND ASSOCIATES INC.



Reneke Creek Existing Conditions

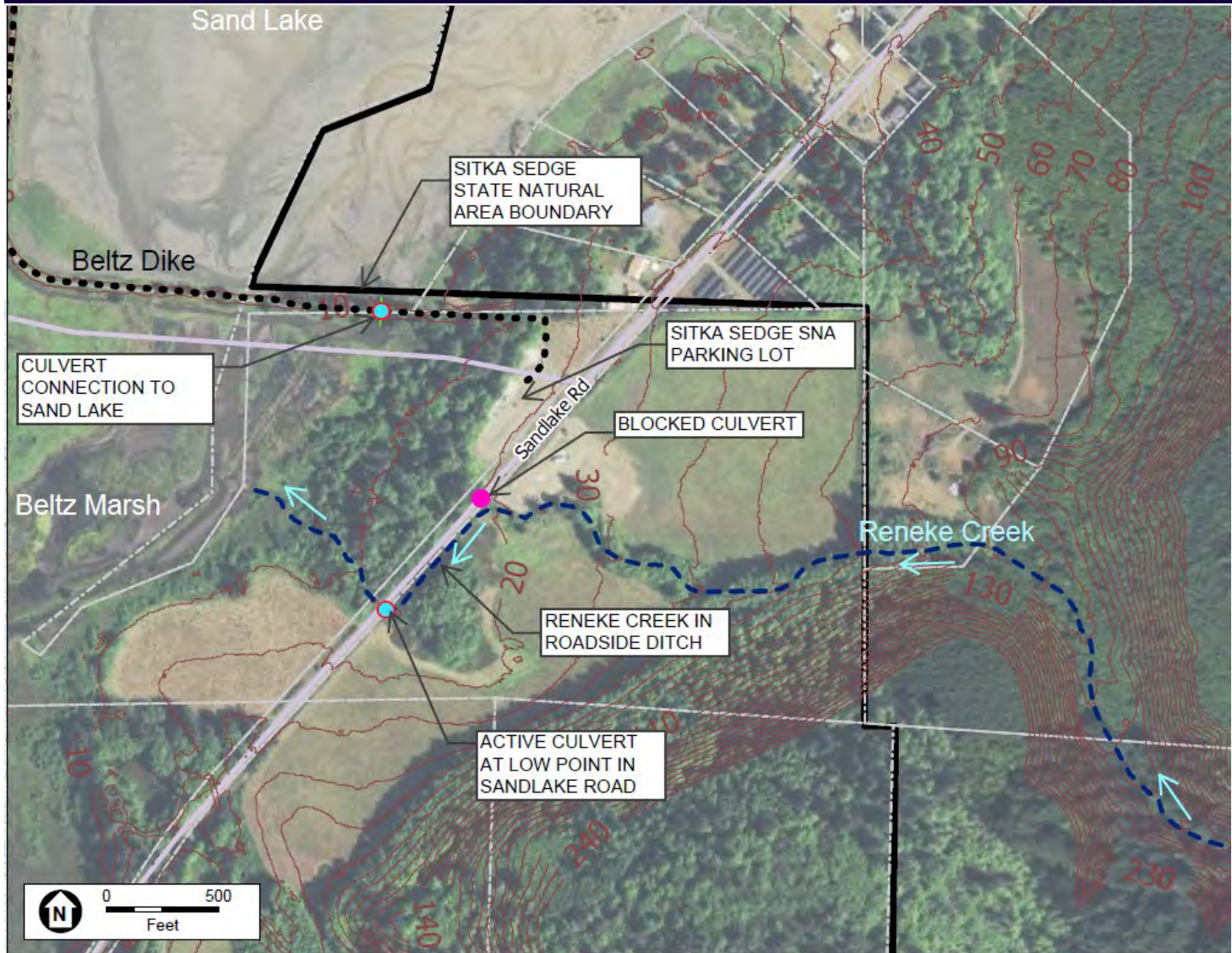

Reneke Creek Hydraulic and Geomorphic Analysis

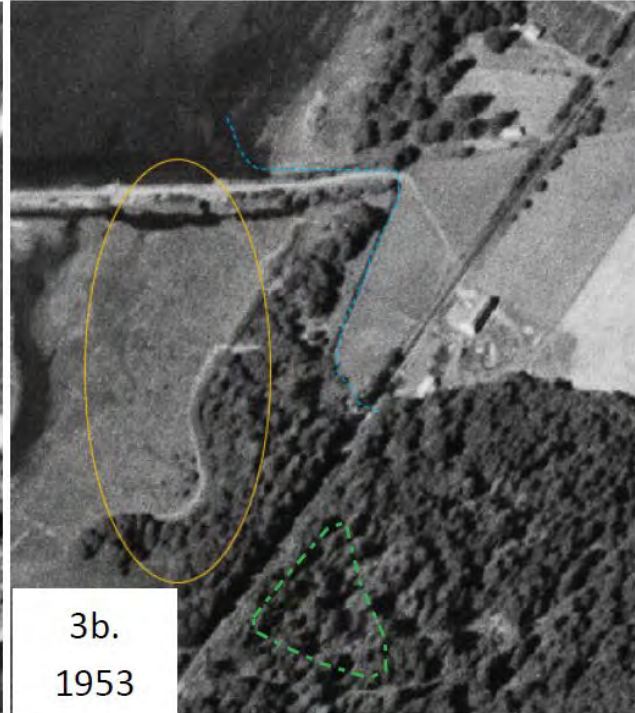
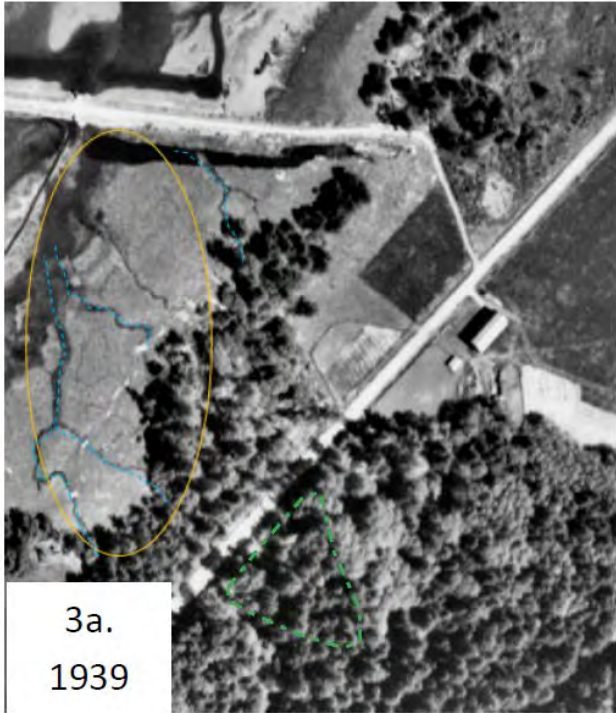

Reneke Creek Hydraulic and Geomorphic Analysis

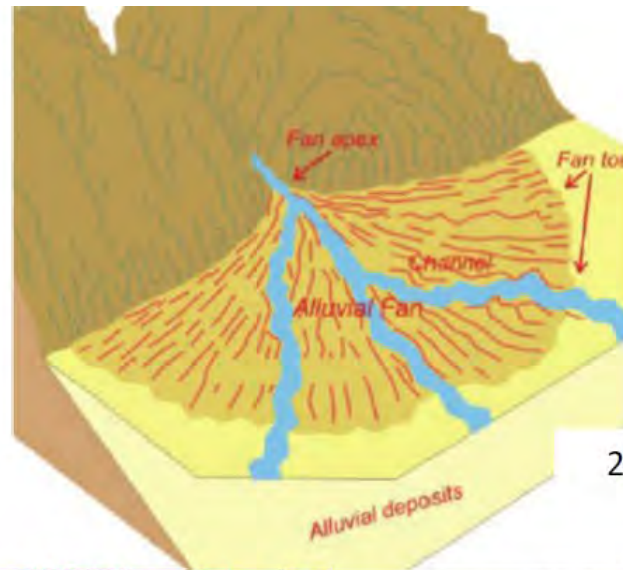

2a. Schematic representation of Alluvial Fan (Ferentinou, et al, 2011)

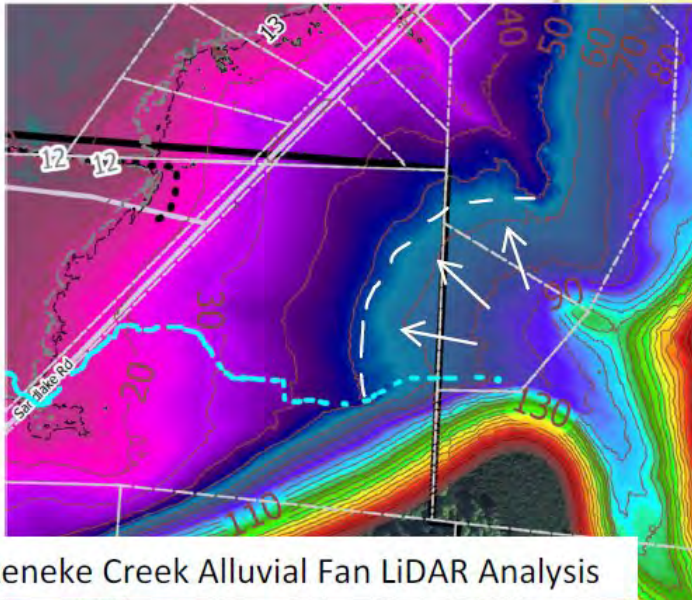

2b. Reneke Creek Alluvial Fan LiDAR Analysis

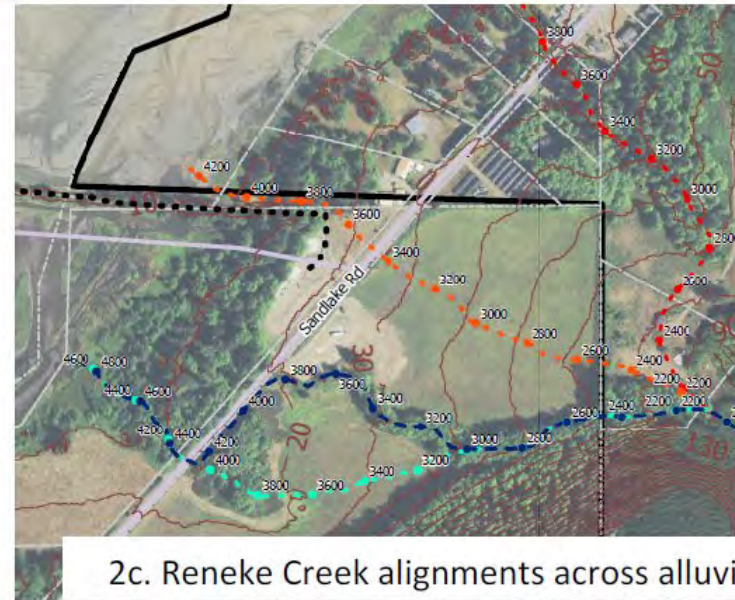

2c. Reneke Creek alignments across alluvial fan

Reneke Creek Hydraulic and Geomorphic Analysis

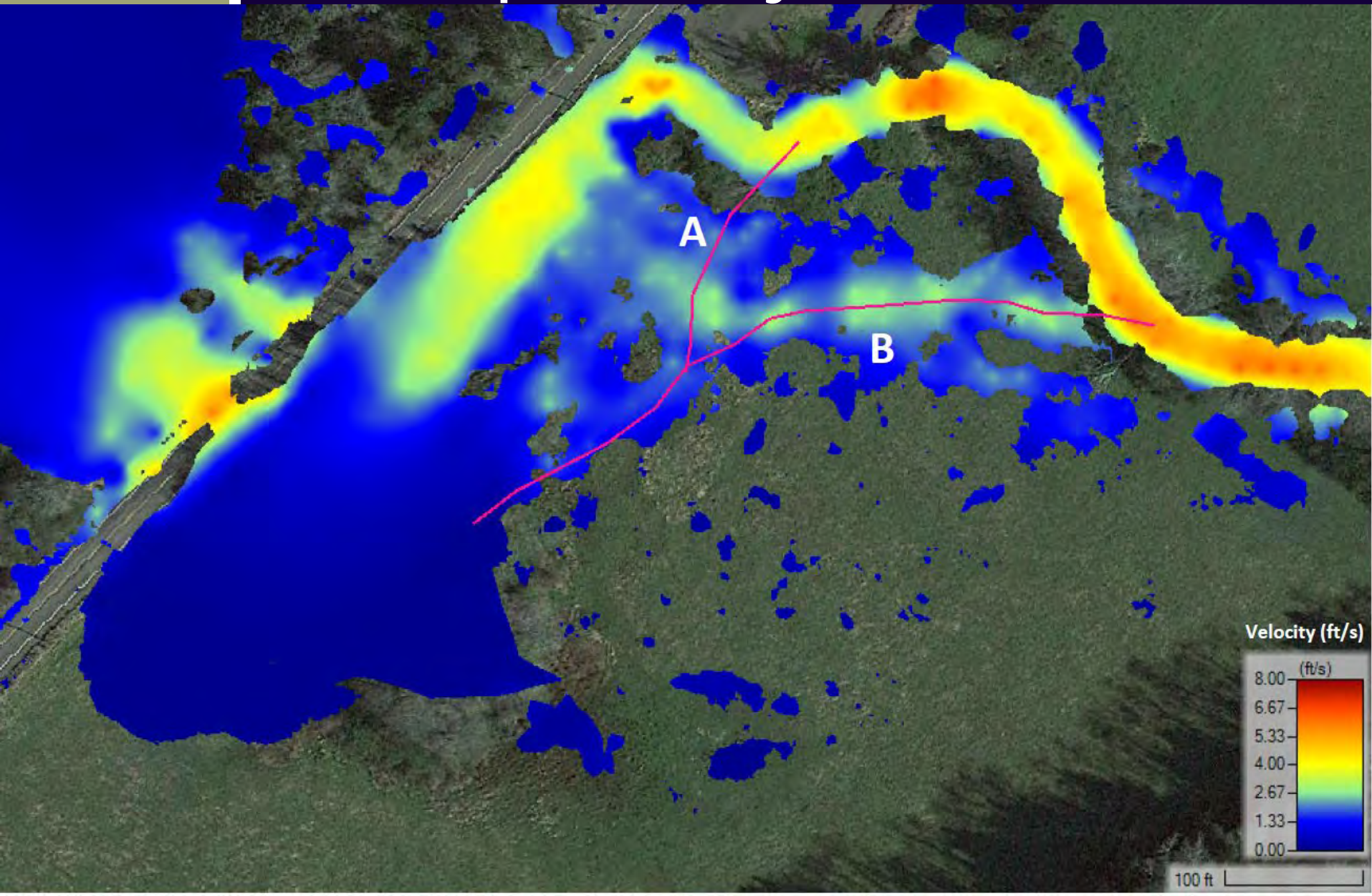

Reneke Creek Hydraulic and Geomorphic Analysis

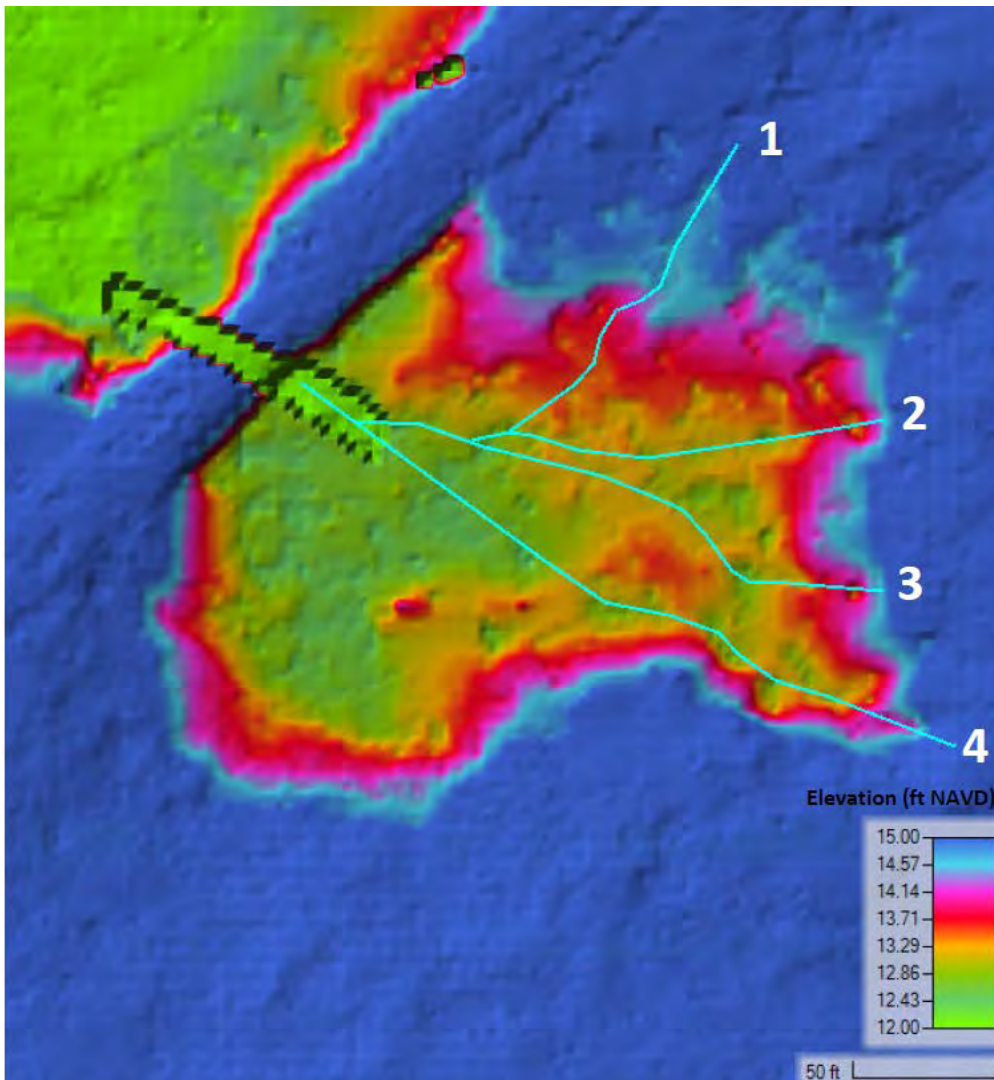

Reneke Creek Hydraulic and Geomorphic Analysis



Reneke Creek Culvert Replacement - 30% Design for Tillamook County Public Works



Reneke Creek Culvert Replacement - 30% Design for Tillamook County Public Works

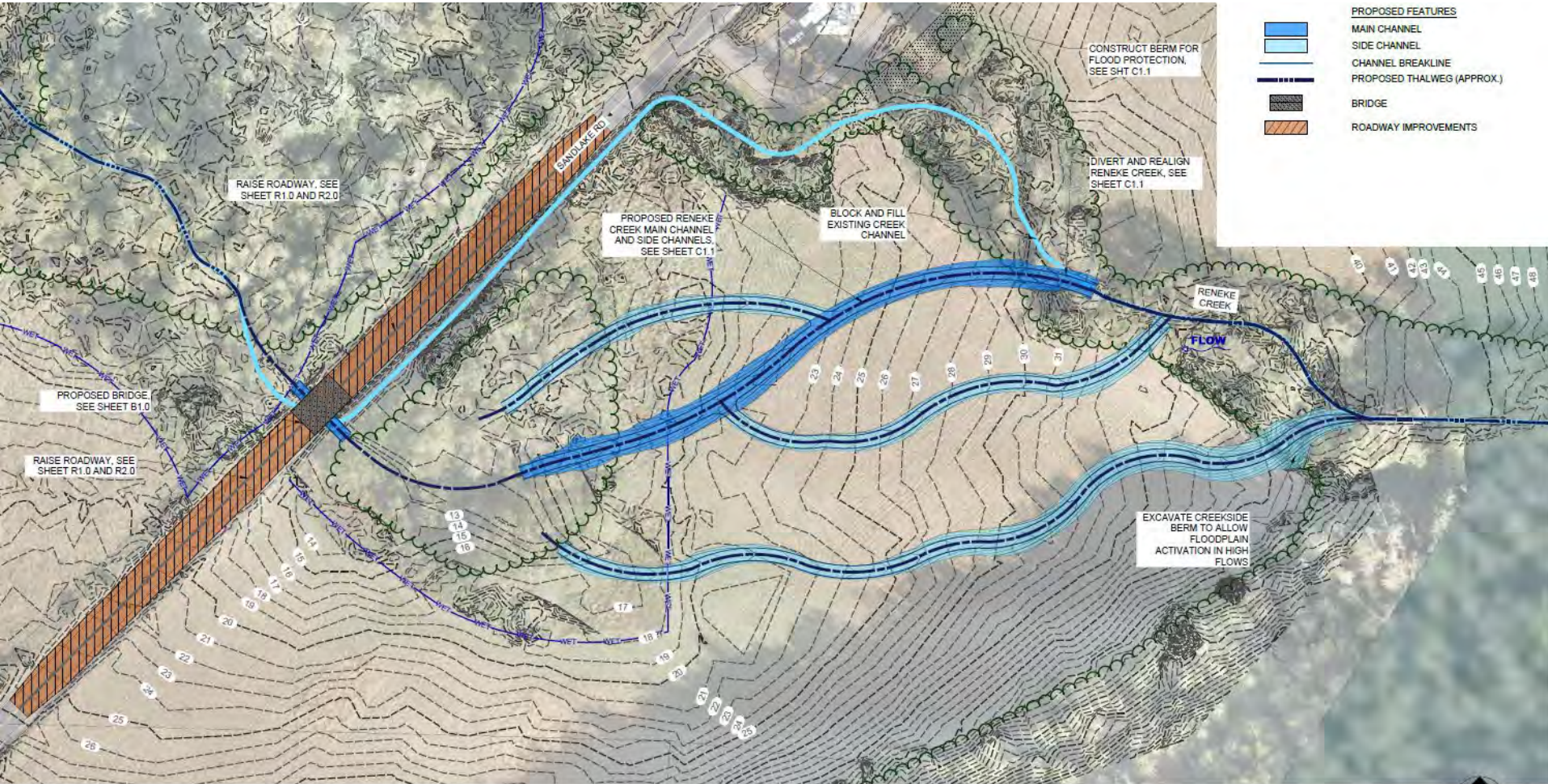

PROPOSED FEATURES

	MAIN CHANNEL
	SIDE CHANNEL
	CHANNEL BREAKLINE
	PROPOSED THALWEG (APPROX.)
	BRIDGE
	ROADWAY IMPROVEMENTS

SITE PLAN AND OVERVIEW
PLAN SCALE: 1" = 50'



Reneke Creek Culvert Replacement - 30% Design for Tillamook County Public Works

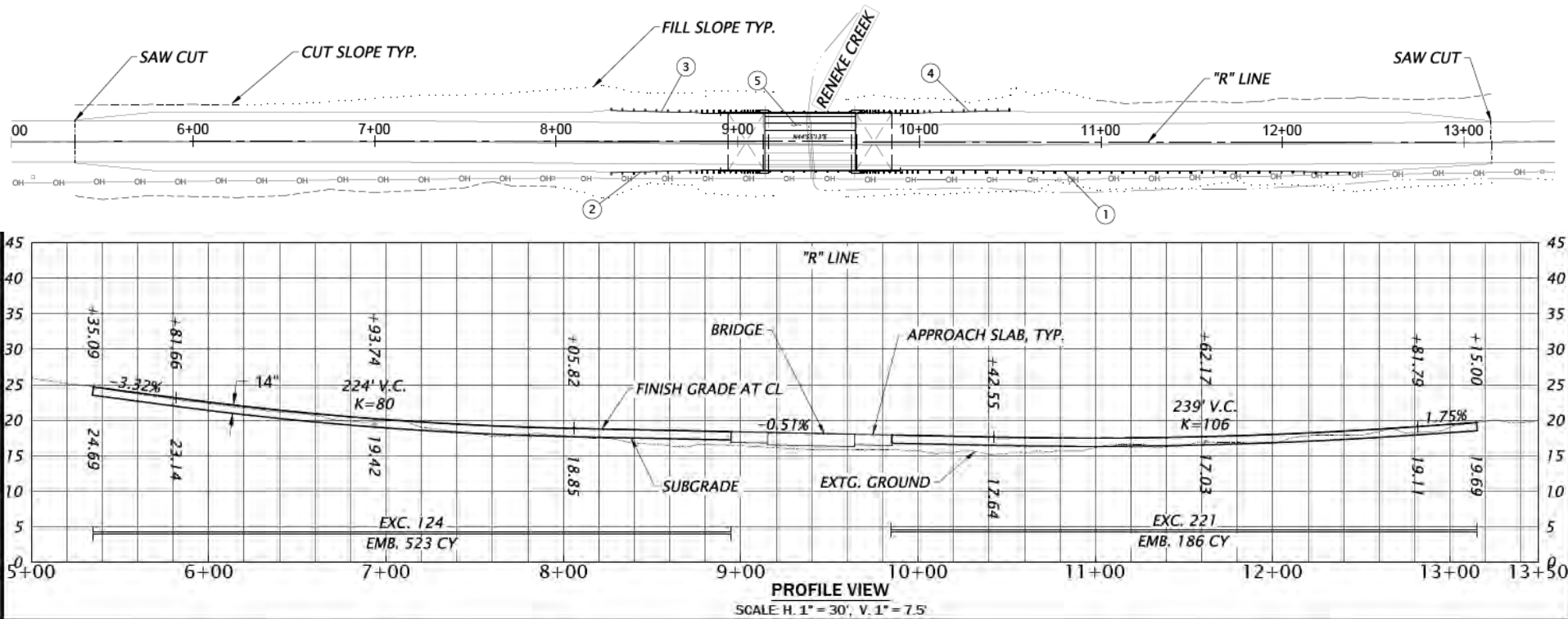

Structural and Roadway Engineering by David Evans and Associates

Reneke Creek Culvert Replacement - 30% Design for Tillamook County Public Works

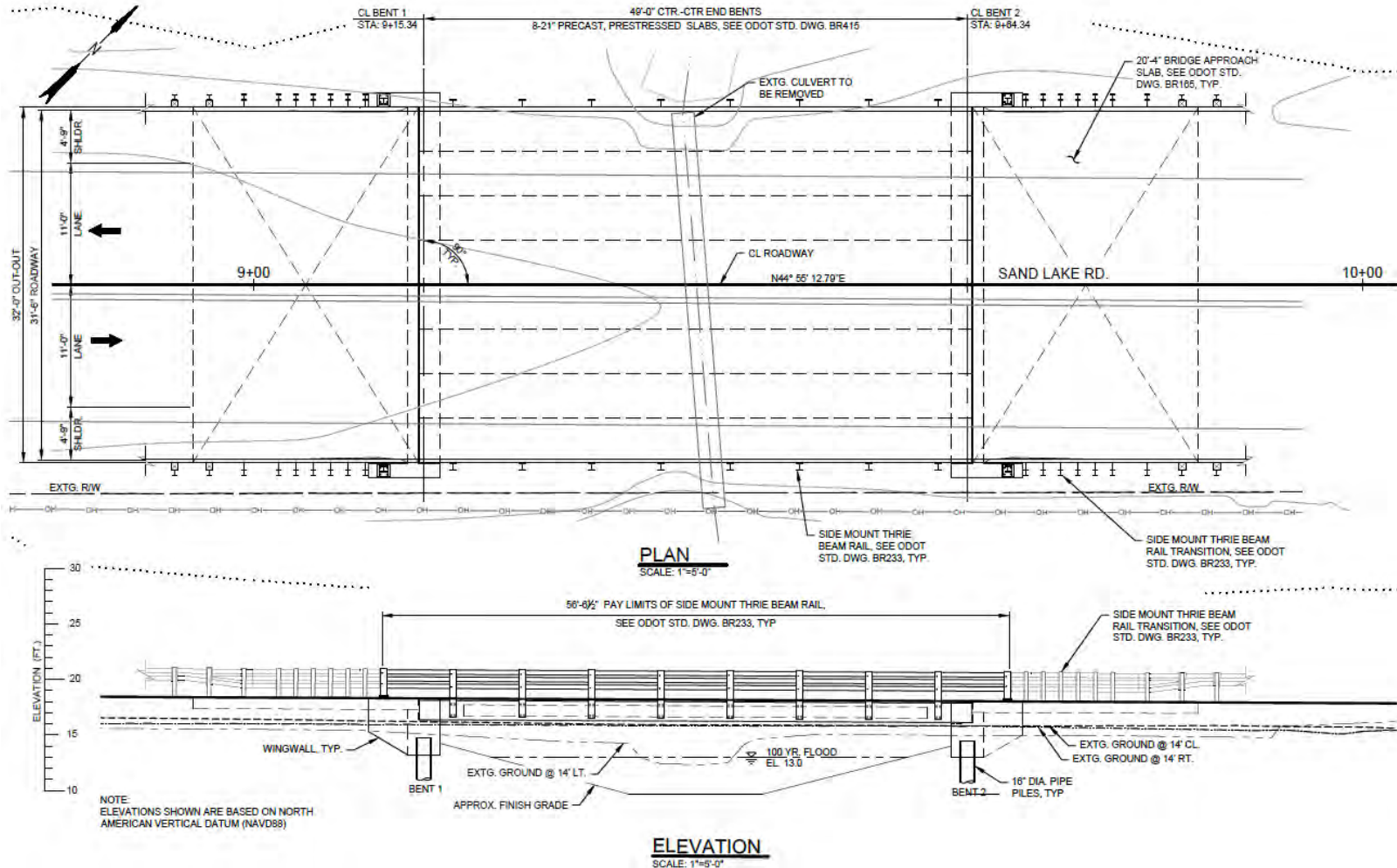

Reneke Creek Culvert Replacement - Next Steps

- Complete 100% Designs and Permitting
- County has applied for Federal Highways grant funding for \$3 Million for construction in partnership with Salmon SuperHwy
- Estimated Construction Cost for Reneke Creek:

<hr/>	
GRAND TOTAL CONSTRUCTION COST	\$ 3,184,079
<hr/>	
STREAM AND RESTORATION PORTION (APPROXIMATE):	\$ 1,270,280
BRIDGE AND ROADWAY PORTION (APPROXIMATE):	\$ 1,913,799

Sitka Sedge Flat Wetland Restoration: Town Hall Meeting – 30% Design Project Update

Questions or Comments?

In person participants:

Please limit questions and comments to 3 minutes to allow everyone a chance to speak.

Online participants:

There is a Q&A function to this meeting through which you can type questions.



**TILLAMOOK
ESTUARIES
PARTNERSHIP**

