

OPERATION & MAINTENANCE MANUAL

Water Quality Bioslope

Manual prepared: February 2019

DFI No. D01223

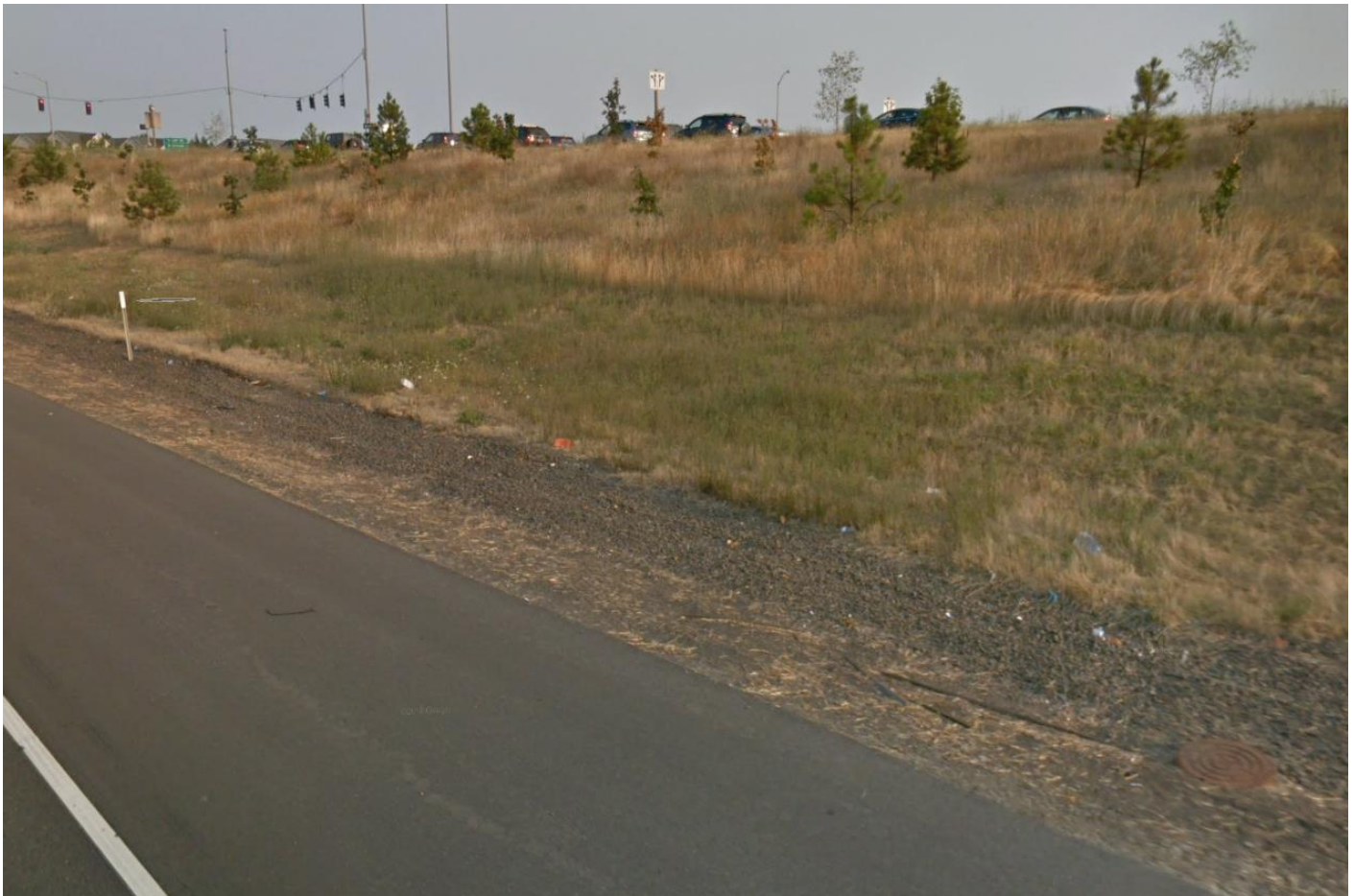

Figure 1: DFI No. D01223, looking southeast

1. Identification

Drainage Facility ID (DFI): D01223
Facility Type: Water Quality Bioslope/Media Filter Drain (MFD)
Construction Drawings: (V-File Numbers) 43V-086
Location: District: 2B
Highway No.: 047
Mile Post: 65.81 – 66.04, [Right side]

2. Manual Purpose

The purpose of this manual is to outline inspection needs and summarize maintenance actions.

3. Facility Location

The location map below details the facility location. The highway, mile posts, side streets, access location, and stormwater flow directions are noted on the map. **NOTE: Mile posts are based off of the V-File, and may vary from TransGIS mile posts.**

Facility location type: **Roadway shoulder**

Flow direction: West



Figure 2: Facility Map

4. Facility Summary

The width is measured perpendicular to the edge of pavement and is equivalent to the flow length. The length is measured parallel to the edge of pavement and is equivalent to the length of the contributing impervious area.

The length and width of the applicable facility components are:

Component	Length (feet)	Width (feet)
Bioslope	1,174	8

The slope of the facility is presented by a vertical distance (rise) followed by the horizontal distance (run).

Side Slope	Rise (feet)	Run (feet)
Bioslope	1	6

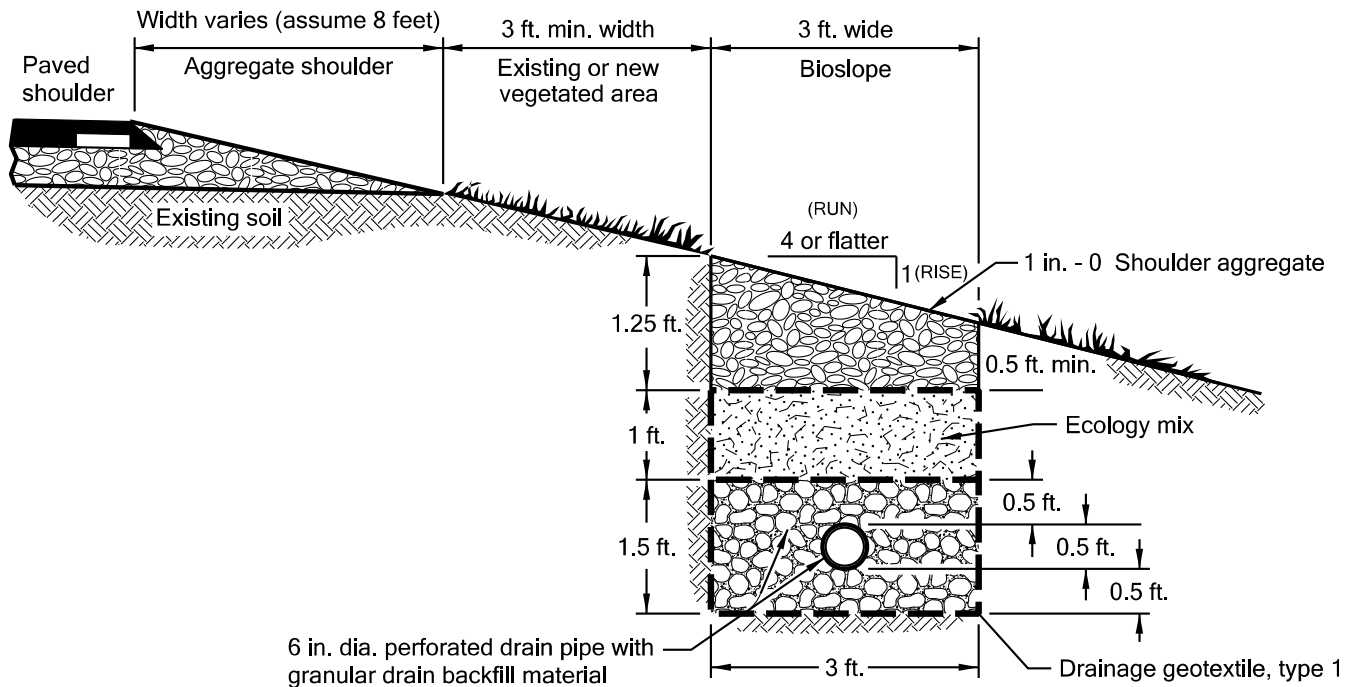

Figure 3: BioSlope Section (Typical)

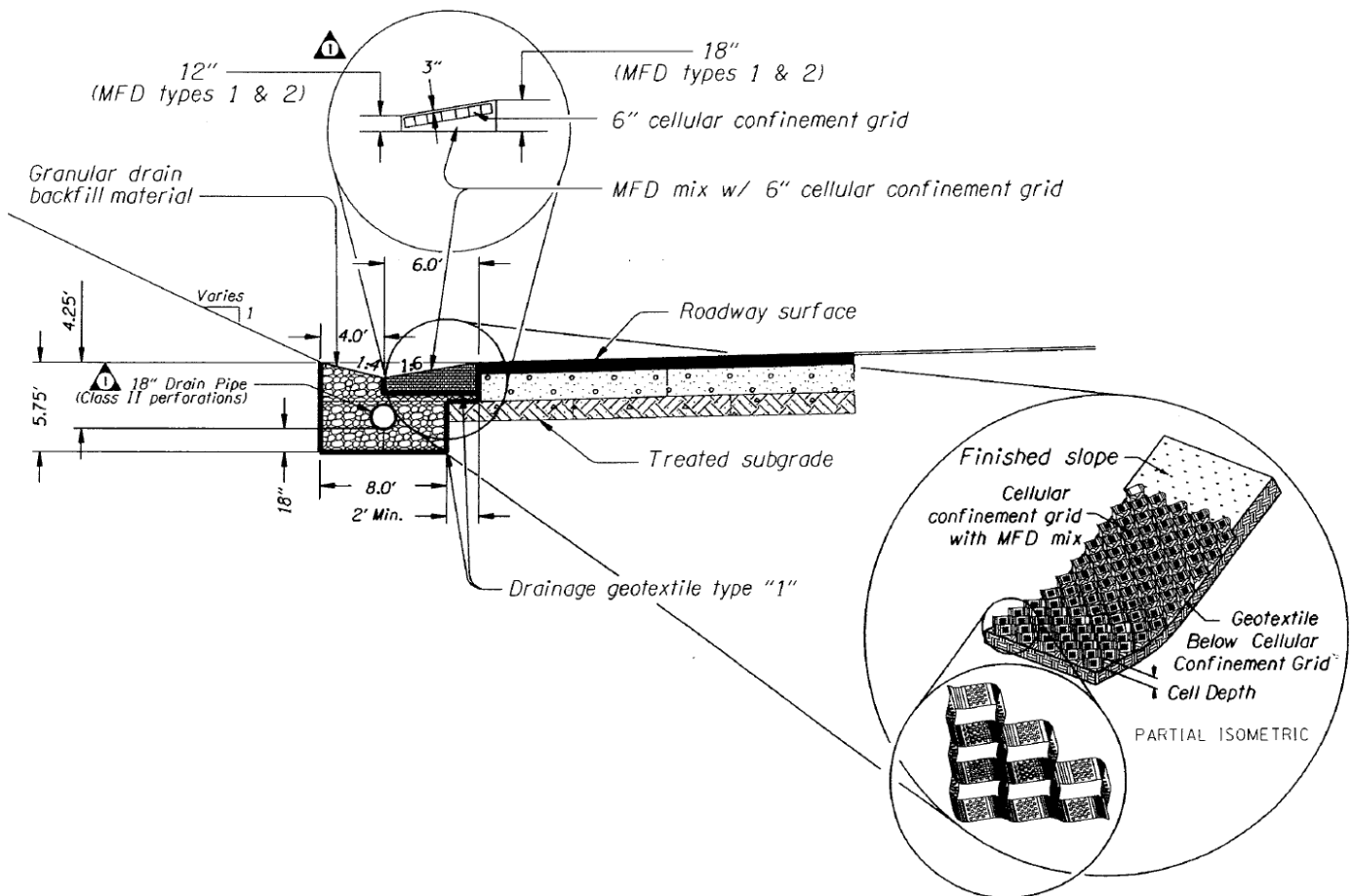

Figure 4: Type 1 bioslope with ditch configuration (No vegetated area/zone)

Site specific: This water quality facility only has a Type 1 bioslope. The water flows through the facility to the west. The water flows through a manhole and exits the facility to the north through a storm drain system. It ultimately drains into Willow Creek.

The facility is a modified version of the typical bioslope (Figure 3). The main difference is the exclusion of a vegetation area between the edge of pavement and the bioslope section. This was developed as a result of right of way limitations, and in some locations, the prohibitive costs of moving adjacent high voltage line and frontage road.

5. Facility Access

Maintenance access to the facility:

<input type="checkbox"/> Roadside pad	<input checked="" type="checkbox"/> Roadside shoulder
<input type="checkbox"/> Access road with Gate	<input type="checkbox"/> Access road without Gate

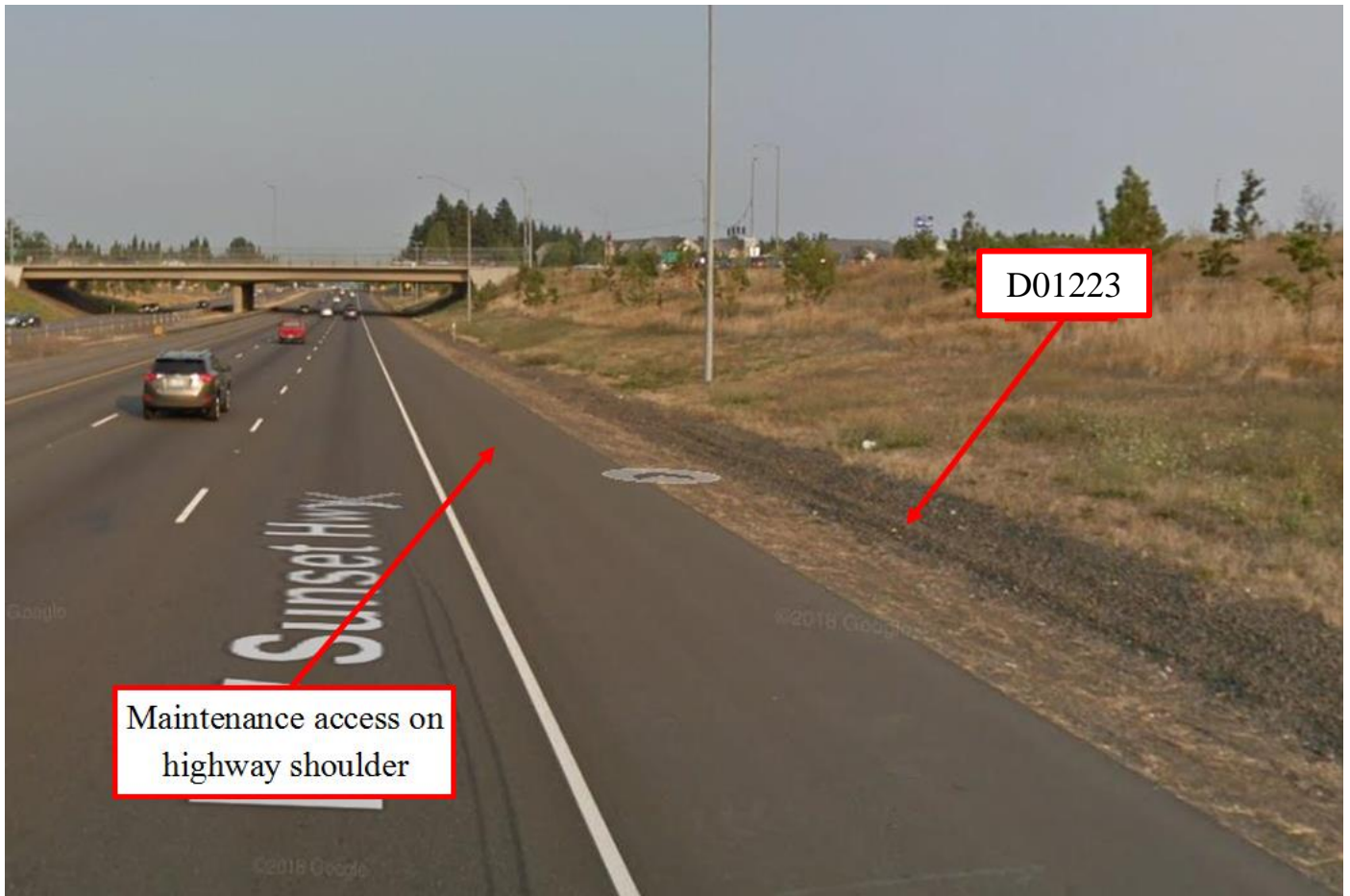

Figure 5: Maintenance Access

6. Operational Components / Maintenance Items

Classification and Standard Operational (Op) Plan:

This facility is classified as a:

<input type="checkbox"/> Filter Strip (Op Plan A)	<input checked="" type="checkbox"/> Bioslope (Op Plan B)
<p>A filter strip consists of a vegetated or media slope located parallel to the edge of pavement. It maintains sheet flow of stormwater runoff over the width of the strip.</p>	<p>A bioslope consists of a filter strip and treatment zone. It is a flow-through stormwater treatment facility located along roadside embankments.</p>
<p>A standard operational plan illustrates the general facility footprint configuration and explains the purpose of each facility component. Operational plans (A, B) are provided in the Standard Operation Manual.</p>	

See Appendix A for the site specific operational plan.

Operational Components

Filter strips and bioslopes have many components that assist with treatment, conveyance, and infiltration of stormwater runoff. The components in use can vary depending on the facility design. The facility components table (Table 1) has been provided to highlight the applicable components for this facility. The component is in use when the box contains an “x” (e.g.).

The Standard Operation Manual for Water Quality Filter Strips and Bioslopes (implemented February 2019) outlines facility operation, typical footprint configuration, and component definitions and details. A link to the manual is attached to the feature marker in TransGIS.

<https://gis.odot.state.or.us/TransGIS/>

Maintenance Items

Operational components marked in Table 1 should be inspected and maintained according to Section 7. Each facility component is defined and detailed in the Standard Operation Manual using the associated ID number indicated below.

Table 1: Bioslope/Filter Strip Components		ID #
Facility Inlet		
Pavement Sheet Flow	<input checked="" type="checkbox"/>	B1
Flow Spreader	<input type="checkbox"/>	B2
Ground Cover		
Vegetated Slope	<input type="checkbox"/>	B3
Aggregate Media Slope	<input type="checkbox"/>	B4
Underground Components		
Water Quality Mix	<input type="checkbox"/>	B5
Ecology Mix	<input checked="" type="checkbox"/>	B6
Granular Drain Backfill Material	<input checked="" type="checkbox"/>	B7
Geotextile Fabric	<input checked="" type="checkbox"/>	B8
Cellular Confinement Grid	<input checked="" type="checkbox"/>	B9
Structures		
Curb/Berm	<input type="checkbox"/>	B10
Check Dam	<input type="checkbox"/>	B11
Cleanout	<input type="checkbox"/>	B12
Facility Outlet		
Perforated Drain Pipe	<input checked="" type="checkbox"/>	B13
Open Slope Outlet	<input type="checkbox"/>	B14
Open Channel Outlet	<input type="checkbox"/>	B15
Storm Drain Outlet Pipe	<input checked="" type="checkbox"/>	B16
Outfall Type		
Waterbody (Creek/Lake/Ocean)	<input type="checkbox"/> C	B17
	<input type="checkbox"/> L	
	<input type="checkbox"/> O	
Outfall Channel	<input type="checkbox"/>	B18
Storm Drain System	<input checked="" type="checkbox"/>	B19
Outfall Components		
Pervious Berm	<input type="checkbox"/>	B20
Riprap Pad	<input type="checkbox"/>	B21

7. Maintenance

Maintenance Frequency/Maintain Records

- a. Inspect annually. Preferably prior to the rainy season.
- b. Clean and maintain as necessary. Refer to Activity 125 for conditions when maintenance is needed.
- c. Keep a record of inspections, maintenance, and repairs.

Maintenance Guide/Maintenance Actions

The ODOT Routine Road Maintenance Water Quality and Habitat Guide (the *Blue Book*) outlines the standard maintenance actions for water quality facilities under Activity 125.

There are standard maintenance tables for standard ODOT designs. The maintenance tables describe the maintenance component, the defect or problem, the condition when maintenance is needed, and the recommended maintenance to correct the problem. Use the following tables to maintain ODOT filter strips and bioslopes:

- Table 1 (General Maintenance): Contains general maintenance and inspection guidelines that are applicable to all ODOT water quality facilities
- Table 4 (Water Quality Filter Strips)
- Table 5 (Water Quality Bioslopes)

The ODOT Maintenance Guide can be viewed at the following website:

<http://www.oregon.gov/ODOT/HWY/OOM/pages/mguide.aspx>

The *Blue Book* can be viewed at the following website:

http://www.oregon.gov/ODOT/Maintenance/Documents/blue_book.pdf

8. Limitations

Filter strips and bioslopes are NOT designed to allow the use of heavy equipment. Vehicles entering the facility can create depressions (tire ruts), damage vegetation, and damage structural components (e.g. flow spreaders). These conditions may result in poor treatment and drainage performance.

9. Waste Material Handling

Material removed from the facility is defined as waste by the Department of Environmental Quality (DEQ). Refer to the road waste section of the ODOT Maintenance Yard Environmental Management System (EMS) Policy and Procedures Manual for disposal options:

<http://www.oregon.gov/ODOT/HWY/OOM/pages/ems.aspx>

Contact any of the following for more detailed information about management of waste materials found on site:

ODOT Clean Water Unit	(503) 986-3008
ODOT Statewide Hazmat Coordinator	(503) 667-7442
ODOT Region 1 Hazmat Coordinator	(503) 731-8290
ODOT Region 2 Hazmat Coordinator	(503) 986-2647
ODOT Region 3 Hazmat Coordinator	(541) 957-3594
ODOT Region 4 Hazmat Coordinator	(541) 388-6186
ODOT Region 5 Hazmat Coordinator	(541) 963-1590
ODEQ Northwest Region Office	(503) 229-5263

A Appendix A – Site Specific Operational Plan

Contents:

Operational Plan: DFI D01223

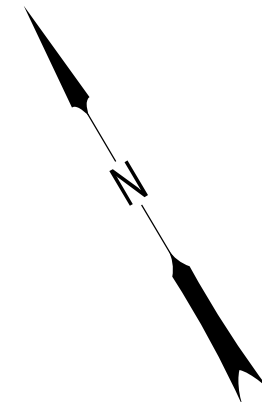
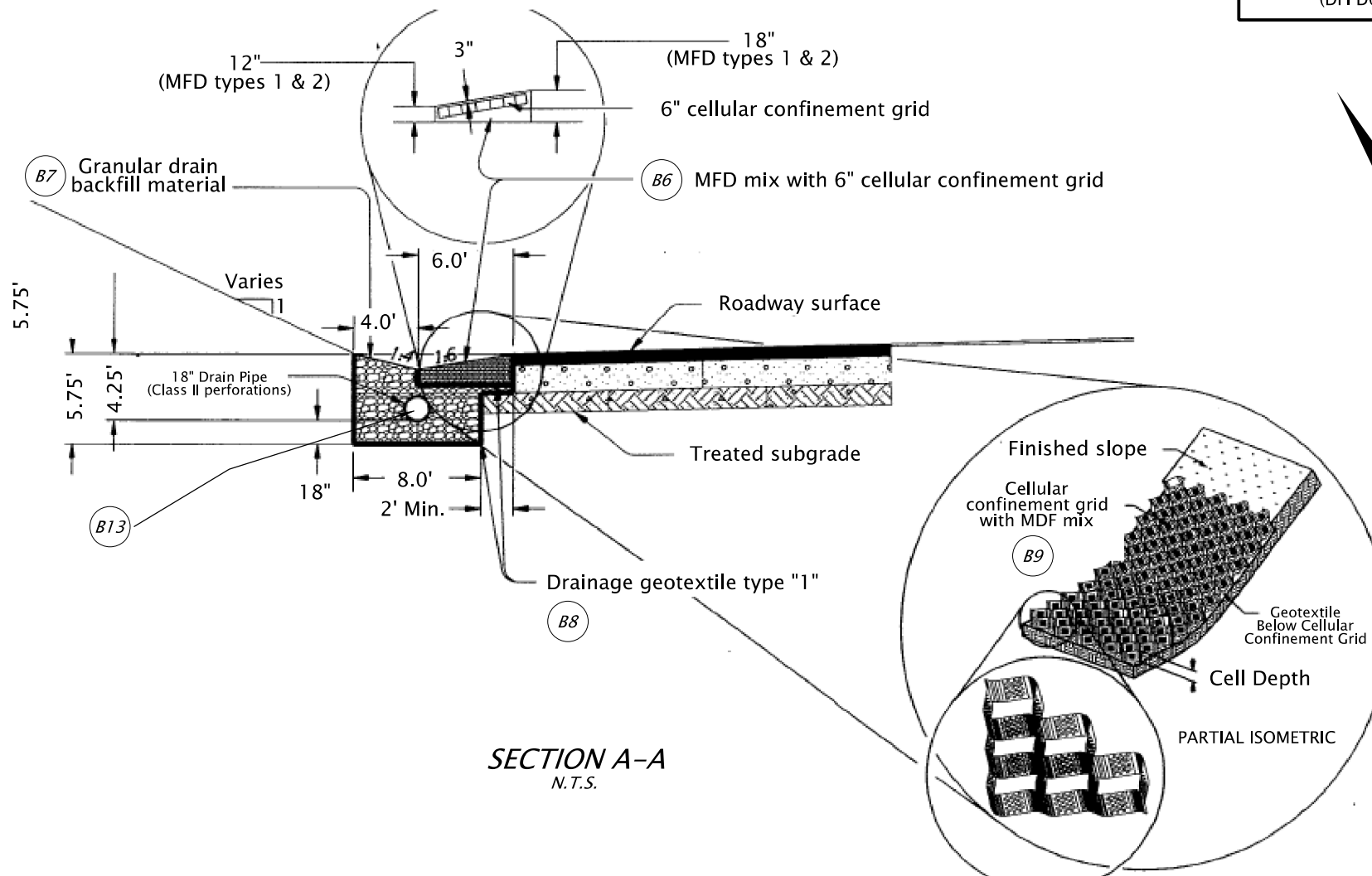
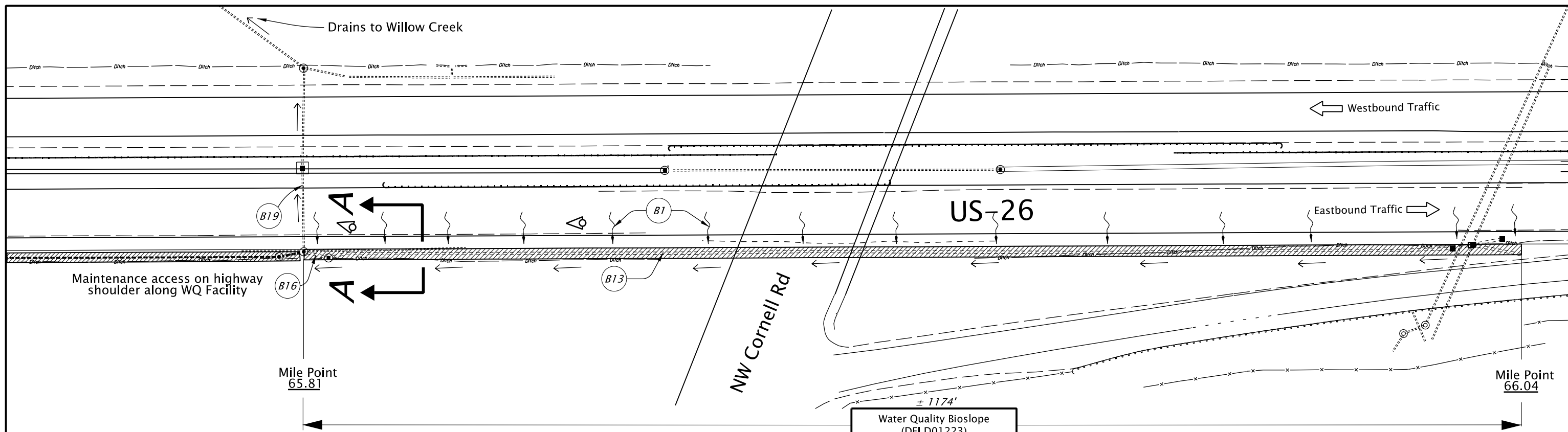

LEGEND	
■	Inlet
⊙	Manhole
→	Water Conveyance Direction
~	Water Flow Direction
⇨	Traffic Flow Direction
▨	Type "1" Bioslope
----	Pipe (Facility)
-----	Pipe (Not part of Facility)
⊙	Photo Location/Direction



Sht. 01 of 01

Prepared By:
Katrina Sepulveda

Drafted By:
Katrina Sepulveda

DFI D01223
MAINTENANCE DISTRICT 2B HWY 047
Water Quality Bioslope
 Sunset Highway MP 65.81 - 66.04
 Washington County

B Appendix B – Project Contract Plans

Contents:

Site Specific Subset of Project Contract Plan 43V-086

INDEX OF SHEETS	
SHEET NO.	DESCRIPTION
1	Title Sheet
1A	Index Of Sheets Cont'd.
1A-2	Std. Drg. Nos.

STATE OF OREGON
DEPARTMENT OF TRANSPORTATION

PLANS FOR PROPOSED PROJECT

GRADING, DRAINAGE, STRUCTURES, PAVING, SIGNING, ILLUMINATION,
SIGNALS & ROADSIDE DEVELOPMENT

US26: NW 185TH AVE - CORNELL ROAD SEC.

SUNSET HIGHWAY
WASHINGTON COUNTY

APRIL 2010

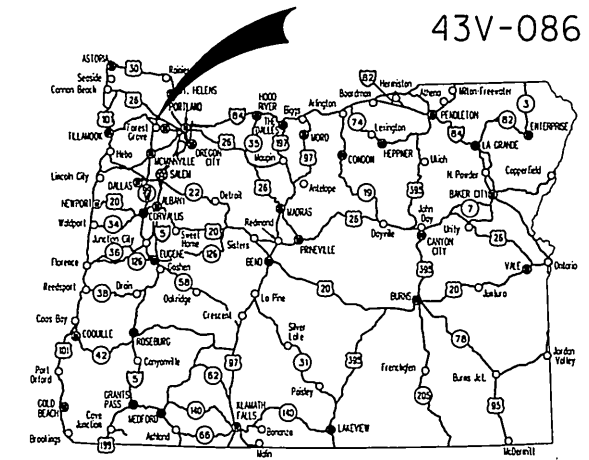

Overall Length Of Site - 2.10 Miles

ATTENTION:
Oregon Law Requires You To Follow Rules Adopted By The Oregon Utility Notification Center. Those Rules Are Set Forth In OAR 952-001-0010 Through OAR 952-001-0090. You May Obtain Copies Of The Rules By Calling The Center. (Note: The Telephone Number For The Oregon Utility Center Is (503) 232-1987.)

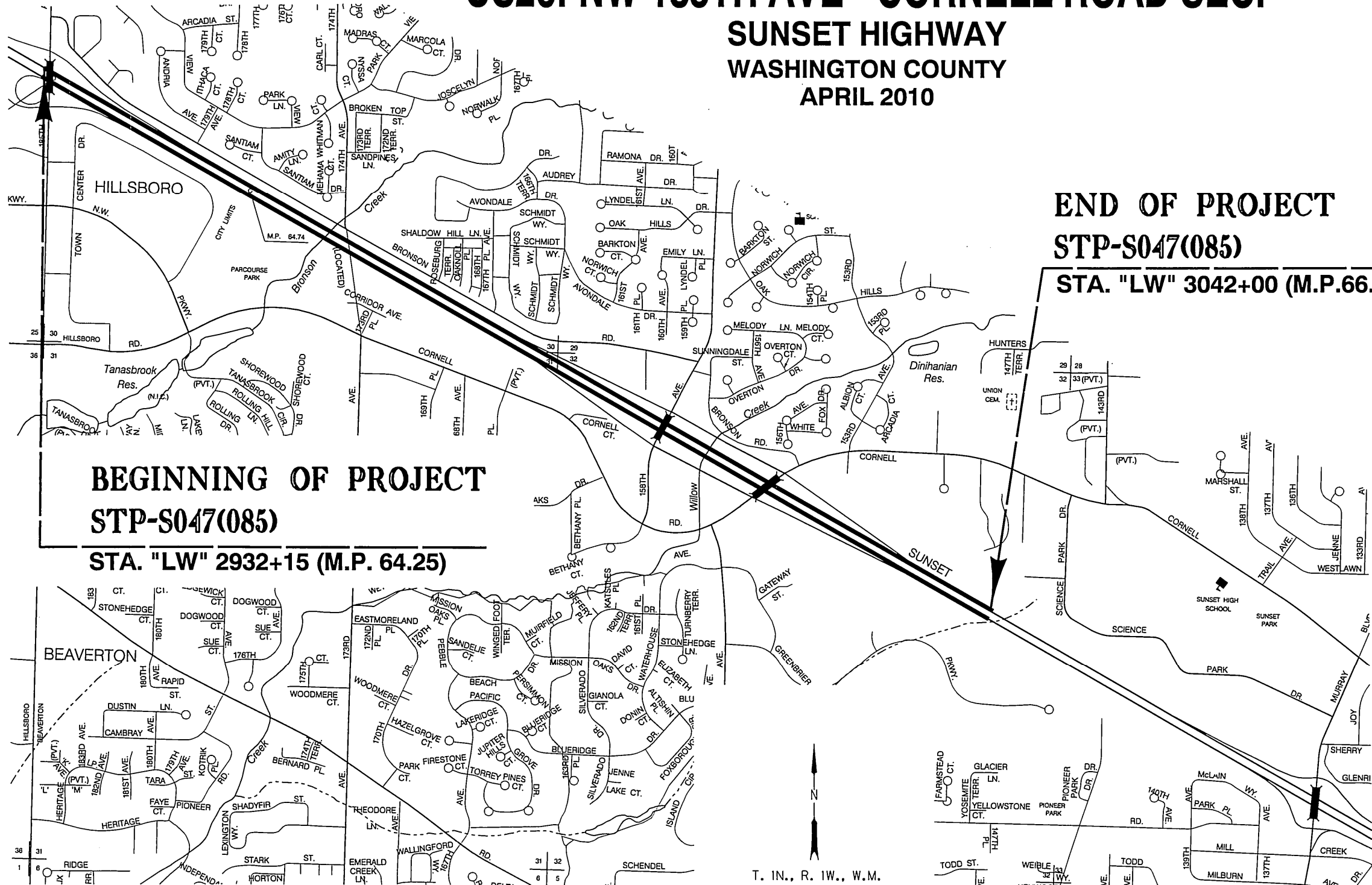

LET'S ALL
WORK TOGETHER
TO MAKE THIS
JOB SAFE

OREGON TRANSPORTATION COMMISSION
Gail Achterman CHAIR
Michael Nelson VICE-CHAIR
Janice Wilson COMMISSIONER
Alan Brown COMMISSIONER
David Lohman COMMISSIONER
Matthew L. Garrett DIRECTOR OF TRANSPORTATION

These plans were developed using ODOT design standards. Exceptions to these standards, if any, have been submitted and approved by the ODOT Chief Engineer or their delegated authority.

By: *Naveen G. Chandra*
Signature & date 2/8/10
Naveen G. Chandra P.E. - R1 Project Delivery Manager
Print name and title
[Signature]
Concurrence by ODOT Chief Engineer

US26: NW 185TH AVE - CORNELL ROAD SEC.
SUNSET HIGHWAY
WASHINGTON COUNTY

FEDERAL HIGHWAY ADMINISTRATION	PROJECT NUMBER	SHEET NO.
OREGON DIVISION	STP-S047(085)	1

INDEX OF SHEETS, CONT'D.	
SHEET NO.	DESCRIPTION
2, 2A, 2A-2 Thru 2A-16	Typical Sections
2B, 2B-2 Thru 2B-3	Details
2C, 2C-2 Thru 2C-24	Traffic Control Plans
2C-25 Thru 2C-31	Detour Plan
2D, 2D-2	Pipe Data Sheet
3	Alignment
3A	General Construction
3B	Drainage & Utilities
3C	Drainage Profile
4	Alignment
4A	General Construction
4B	Drainage & Utilities
4C	Drainage Profile
5	Alignment
5A	General Construction
5B	Drainage & Utilities
5C	Drainage Profile
6	Alignment
6A	General Construction
6B	Drainage & Utilities
6C	Drainage Profile
7	Alignment
7A	General Construction
7B	Drainage & Utilities
6C	Drainage Profile
8	Alignment
8A	General Construction
8B	Drainage & Utilities
8C	Drainage Profile
9	Alignment
9A	General Construction
9B	Drainage & Utilities
9C	Drainage Profile
10	Alignment
10A	General Construction
10B	Drainage & Utilities
10C	Drainage Profile
11	Alignment
11A	General Construction
11B	Drainage & Utilities
11C	Drainage Profile
12	Alignment
12A	General Construction
12B	Drainage & Utilities
12C	Drainage Profile

INDEX OF SHEETS, CONT'D.	
SHEET NO.	DESCRIPTION
PERMANENT PAVEMENT MARKERS	
ST	Striping Details
ST-2 Thru ST-11 Incl.	Striping Plan
GEO/HYDRO	
GA, GA-2 Thru GA-11 Incl.	Erosion Control Plan
GA-12 Thru GA-15 Incl.	Erosion Control Details
ROADSIDE DEVELOPMENT	
GN, GN-2 Thru GN-8	Roadside Development Details
GN-9 Thru GN-12	Roadside Development Plan

DRAWING NO.	SHEET NO.	DESCRIPTION
83488	GB	Geotechnical Data
83495	GB-2	Geotechnical Data
83498	GB-3	Geotechnical Data
83499	GB-4	Geotechnical Data
BRIDGE NO. 21329 - NORTH RETAINING WALL		
83489	GC	Retaining Wall Plan & Profile
83490	GC-2	Retaining Wall Plan & Profile
83491	GC-3	Retaining Wall Plan & Profile
83492	GC-4	Retaining Wall Plan & Profile
BRIDGE NO. 21328 - SOUTH RETAINING WALL		
83496	GC-5	Retaining Wall Plan & Profile
83493	GC-6	North Retaining Wall Details
83494	GC-7	South Retaining Wall Details
83497	GC-8	Retaining Wall Details

INDEX OF SHEETS, CONT'D.	
DRAWING NO.	DESCRIPTION
PERMANENT SIGNING	
S-11907 Thru S-11925 Incl.	Sign Installation Plan
S-11926 Thru S-11935 Incl.	Sign Details
S-11936 Thru S-11944 Incl.	Sign Post & Data Table
ILLUMINATION	
I-1688 Thru I-1698 Incl.	Illumination Plan
I-1699	Illumination Details
TRAFFIC SIGNALS	
ITS-889 Thru ITS-895 Incl.	Communication Plan
15564 Thru 15568 Incl.	Ramp Meter Plan
15569	Ramp Meter Details
AUTOMATED TRAFFIC RECORDER #34-010	
TDS-485	Base Mounted Service Cabinet
TDS-34-010A	Traffic Recorder Plan Legend
TDS-34-010B	Traffic Recorder Loop Details
SIGN SUPPORTS	
BRIDGE NO. 08404A - NW MURRAY BLVD.	
83409	Plan, Elevation & Section
83410	Details
BRIDGE NO. 08910A - NW CORNELL RD.	
83411	Plan, Elevation & Section
BRIDGE NO. 16966 - NW BETHANY BLVD.	
83412	Plan, Elevation & Section
CANTILEVER SIGN STRUCTURES	
S-11945	Plan & Elevation

US26: NW 185TH AVE - CORNELL ROAD SEC. SUNSET HIGHWAY WASHINGTON COUNTY		
FEDERAL HIGHWAY ADMINISTRATION	PROJECT NUMBER	SHEET NO.
OREGON DIVISION	STP-SO47(085)	1A

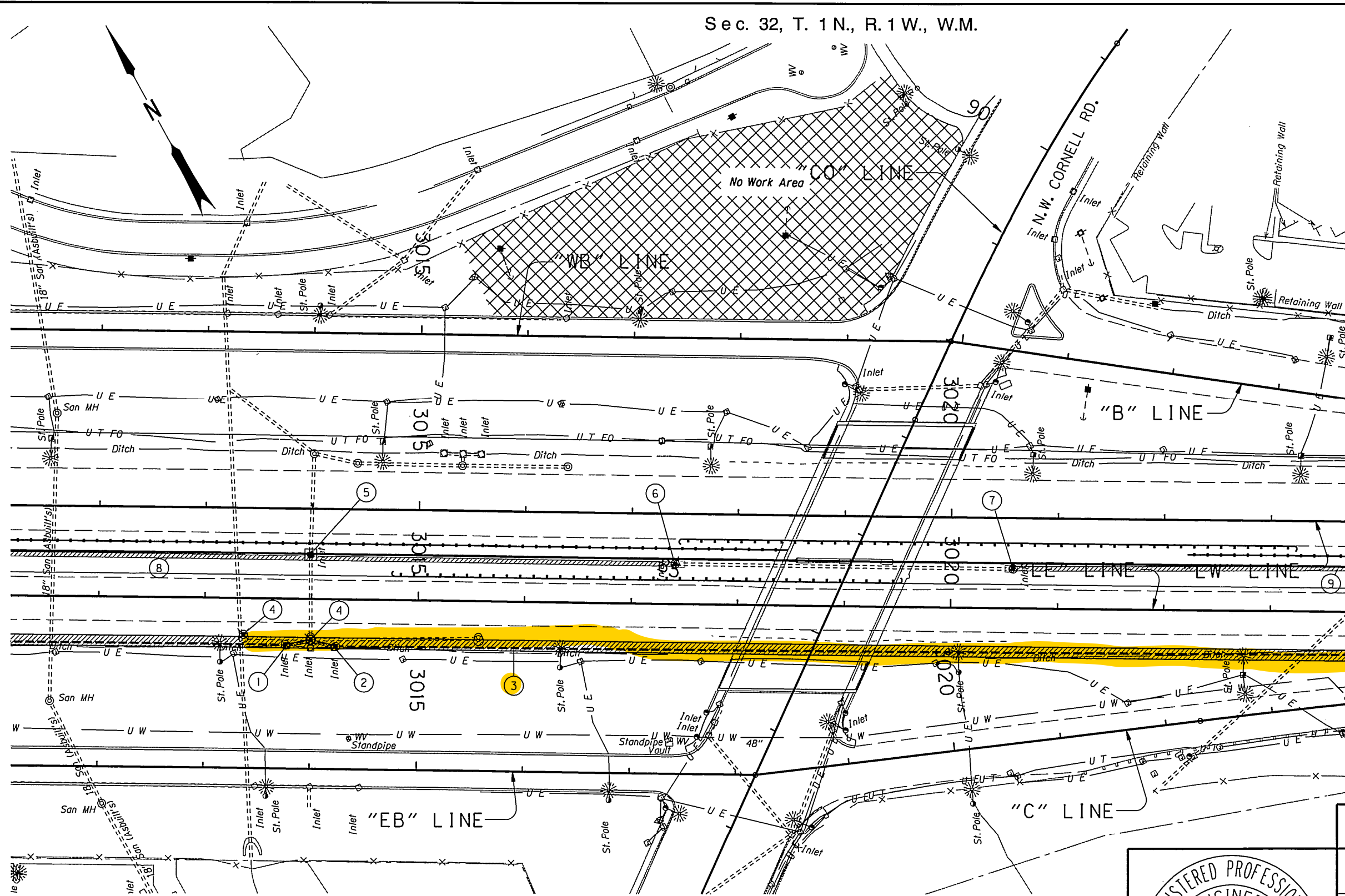

- ① Sta. "LE" 3013+76.29, 43.00 Rt.
Remove inlet
Const. storm sewer pollution control manhole, (Mod.)
Inst. 18" sew. pipe - 23.9'
5' depth
(For details, see sht. GJ-3)
- ② Sta. "LE" 3014+23.03, 44.00 Rt.
Remove inlet
Const. storm sewer pollution control manhole, (Mod.)
Inst. 18" sew. pipe - 24.1'
5' depth
(For details, see sht. GJ-3)
- ③ See sht. 8B note 15
Const. MFD
- ④ Adjust manhole - 2
(See drg. no. RD360)
- ⑤ Sta. "LE" 3013+98.48, Lt.
Remove inlet
Constr. shallow manhole around extg. 24" CMP
Connect median drain pipes to manhole
- ⑥ Sta. "LE" 3017+41.00, Lt.
Const. shallow manhole
Connect extg. 24" CMP to manhole
Connect drain pipe to manhole
Match extg. F.L. through manhole with both pipes
- ⑦ Sta. "LE" 3020+58.00, Lt.
Const. shallow manhole
Connect extg. 24" CMP to manhole
Connect drain pipe to manhole
Match extg. F.L. through manhole with both pipes
- ⑧ See sht. 9B note 8
Const. median drain
- ⑨ Sta. "LW" 3020+58.00, 42.00' Rt.
to Sta. "LW" 3028+90.00, 42.00' Rt.
Const. median drain - 832'
(For details, see sht. GJ-2)



Maintain minimum 6 foot clearance between edge of existing 48" dia. waterline and all excavations.

Protect and preserve existing waterlines.

- Adjust manhole shown thus:
- Remove manhole shown thus:
- Adjust inlet shown thus:
- Remove inlet shown thus:
- Plug and abandon pipe shown thus:

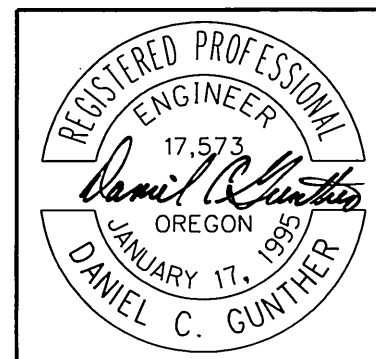

RENEWAL DATE: 6-30-2011

OREGON DEPARTMENT OF TRANSPORTATION

US26: NW 185TH AVE - CORNELL ROAD SEC.
SUNSET HIGHWAY
WASHINGTON COUNTY

Reviewed By - Bruce Council
Designed By - Dan Gunther
Drafted By - Dan Gunther

DRAINAGE & UTILITIES

SHEET NO.
10B

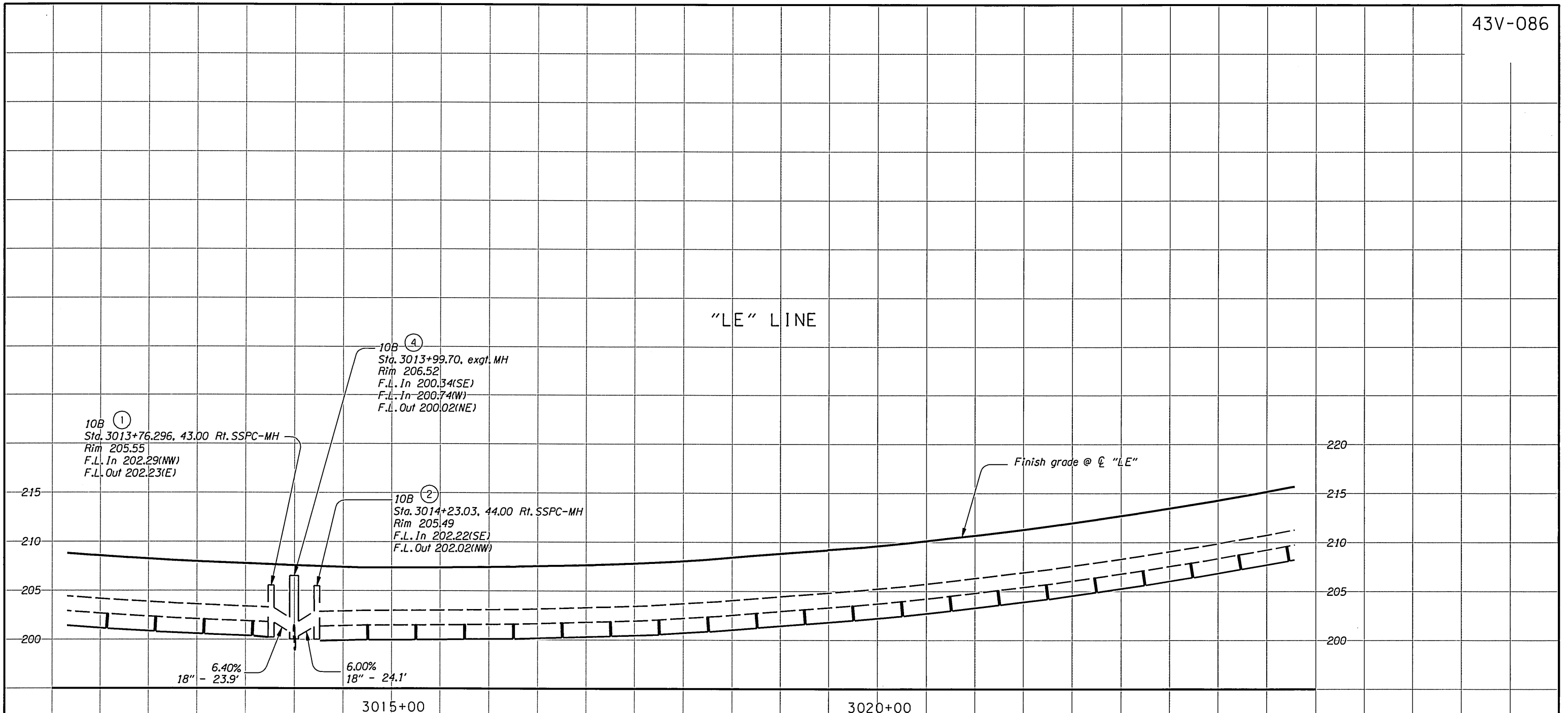

"LE" LINE

10B (1)
Sta. 3013+76.296, 43.00 Rt. SSPC-MH
Rim 205.55
F.L. In 202.29(NW)
F.L. Out 202.23(E)

10B (4)
Sta. 3013+99.70, exgl. MH
Rim 206.52
F.L. In 200.34(SE)
F.L. In 200.74(W)
F.L. Out 200.02(NE)

10B (2)
Sta. 3014+23.03, 44.00 Rt. SSPC-MH
Rim 205.49
F.L. In 202.22(SE)
F.L. Out 202.02(NW)

6.40%
18" - 23.9'

6.00%
18" - 24.1'

Finish grade @ LE

3015+00

3020+00

 OREGON DEPARTMENT OF TRANSPORTATION

US26: NW 185TH AVE - CORNELL ROAD SEC.
SUNSET HIGHWAY
WASHINGTON COUNTY

Reviewed By - Bruce Council
Designed By - Dan Gunther
Drafted By - Dan Gunther

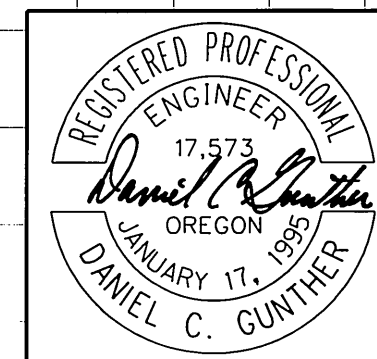

RENEWAL DATE: 6-30-2011

DRAINAGE PROFILE

SHEET NO.
10C

Sec. 32, T. 1 N., R. 1 W., W.M.

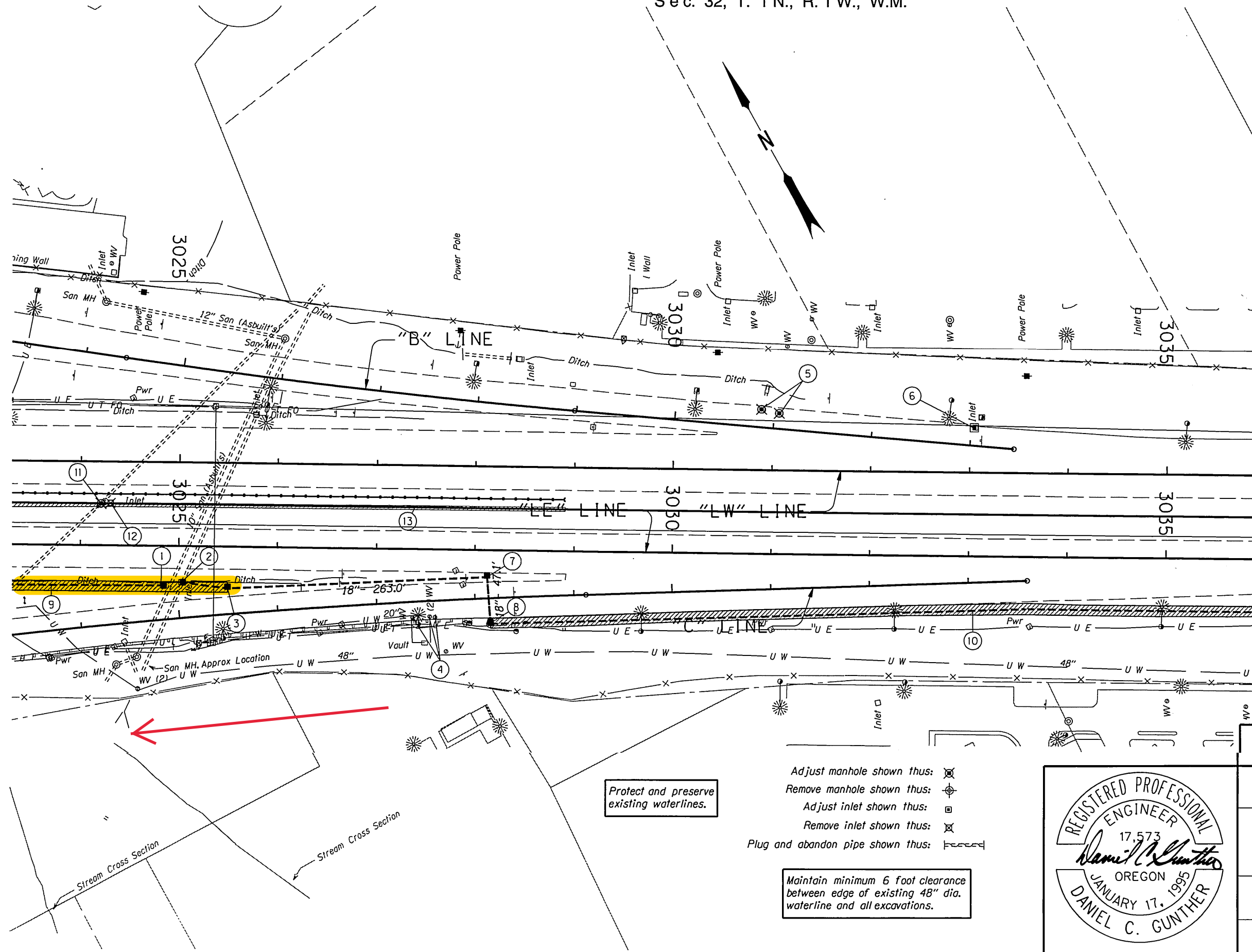

- ① Sta. "LE" 3024+82.28, 40.0 Rt.
Const. type "PVC" inlet
(For details, see sht. GJ-2)
- ② Sta. "LE" 3025+02.67, 36.41 Rt.
Connect drain pipe to exist. inlet
F.L. 210.00 into inlet
- ③ Sta. "LE" 3025+50.00, 42.00 Rt.
Const. type "PVC" inlet
Inst. 18" drain pipe - 47.6'
5' depth
(For details, see sht. GJ-2)
- ④ Adjust water valve to grade - 3
(By others)
- ⑤ Adjust manhole - 2
- ⑥ Adjust inlet
- ⑦ Sta. "LE" 3028+12.59, 27.21 Rt.
Const. type "PVC" inlet
Inst. 18" sew. pipe - 263.0'
5' depth
(For details, see sht. GJ-2)
- ⑧ Sta. "LE" 3028+16.61, 74.10 Rt.
Const. storm sewer pollution control
manhole, (Mod.)
Inst. 18" sew. pipe - 47.1'
5' depth
Trench resurf. - 16 sq.yd.
(For details, see sht. GJ-3)
- ⑨ See sht. 8B note 15
- ⑩ Sta. "LE" 3028+16.61
to Sta. "LE" 3041+99.97
Const. MFD - 1384' (Type 1)
- ⑪ Sta. "LE" 3024+20.44, Lt.
Connect median drain pipes to MH
Adjust manhole
- ⑫ Sta. "LE" 3024+30.39, 42.36 Lt.
Remove inlet
- ⑬ See sht. 10B note 9
Const. median drain

Protect and preserve existing waterlines.

- Adjust manhole shown thus:
- Remove manhole shown thus:
- Adjust inlet shown thus:
- Remove inlet shown thus:
- Plug and abandon pipe shown thus:

Maintain minimum 6 foot clearance between edge of existing 48" dia. waterline and all excavations.

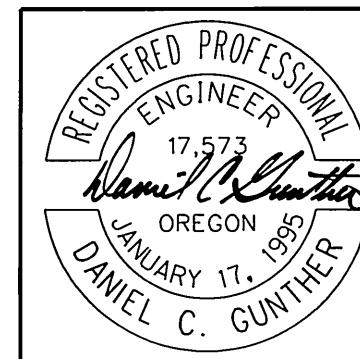

RENEWAL DATE: 6-30-2011

OREGON DEPARTMENT OF TRANSPORTATION	
REGION 1 - GEO/HYDRO UNIT	
US26: NW 185TH AVE - CORNELL ROAD SEC. SUNSET HIGHWAY WASHINGTON COUNTY	
Reviewed By - Bruce Council Designed By - Dan Gunther Drafted By - Dan Gunther	
DRAINAGE & UTILITIES	SHEET NO. 11B

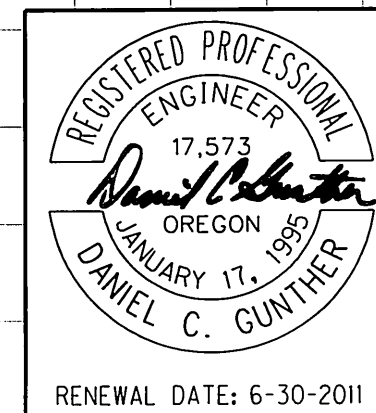
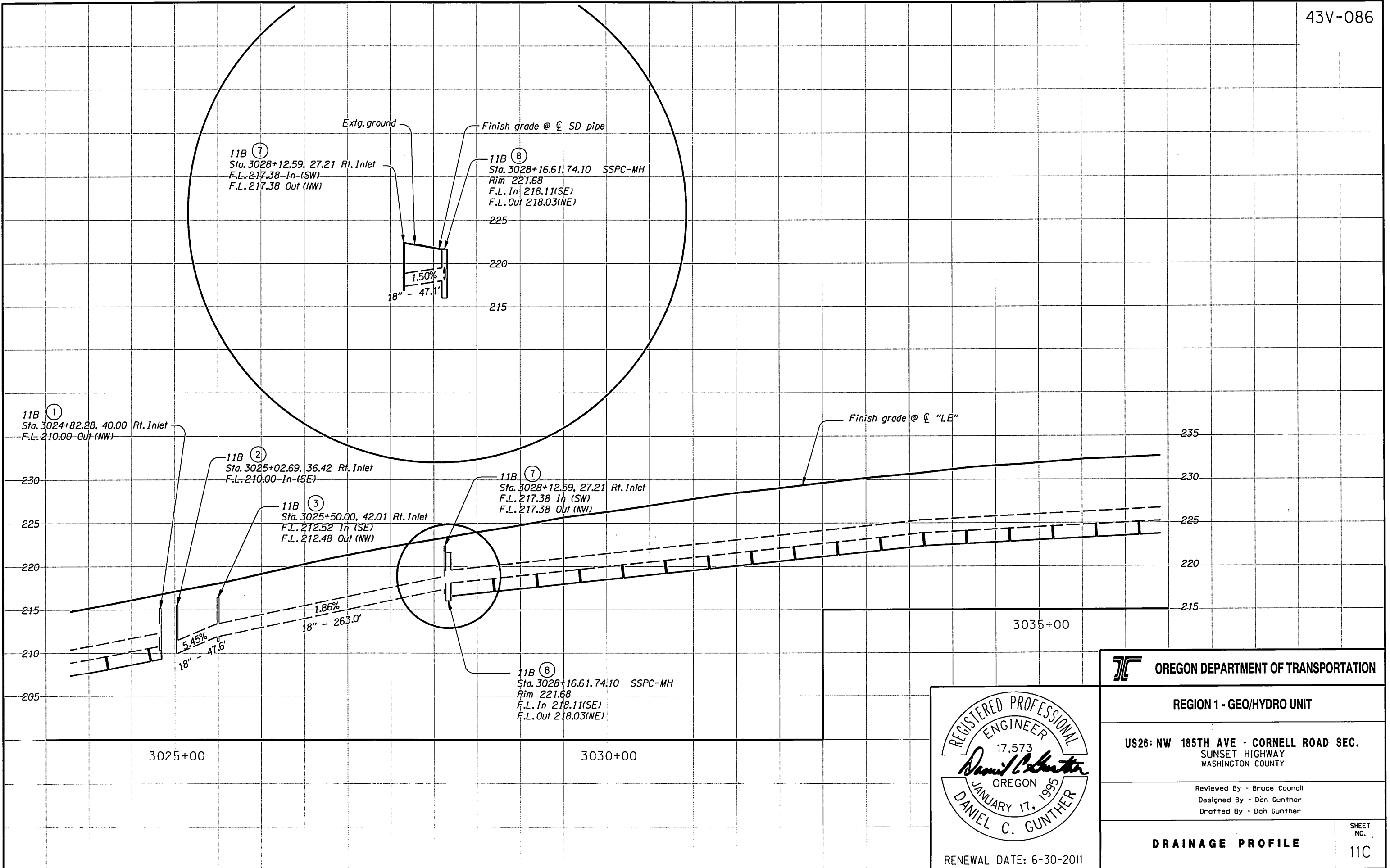

OREGON DEPARTMENT OF TRANSPORTATION	
REGION 1 - GEO/HYDRO UNIT	
US26: NW 185TH AVE - CORNELL ROAD SEC. SUNSET HIGHWAY WASHINGTON COUNTY	
Reviewed By - Bruce Council Designed By - Dan Gunther Drafted By - Dan Gunther	
DRAINAGE PROFILE	SHEET NO. 11C

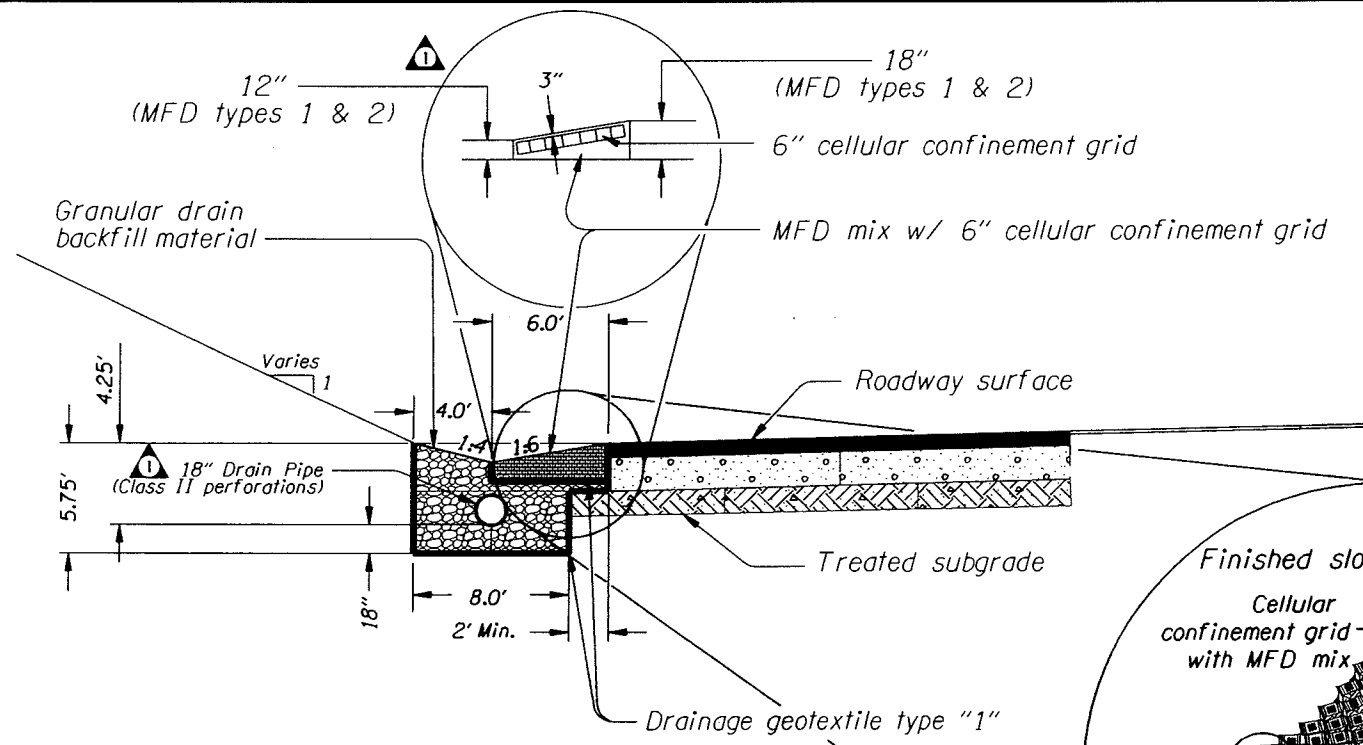

MFD (TYPE 1) SECTION DITCH CONFIGURATION

Horiz. Scale: 1"=10'
Vert. Scale: 1"=10'

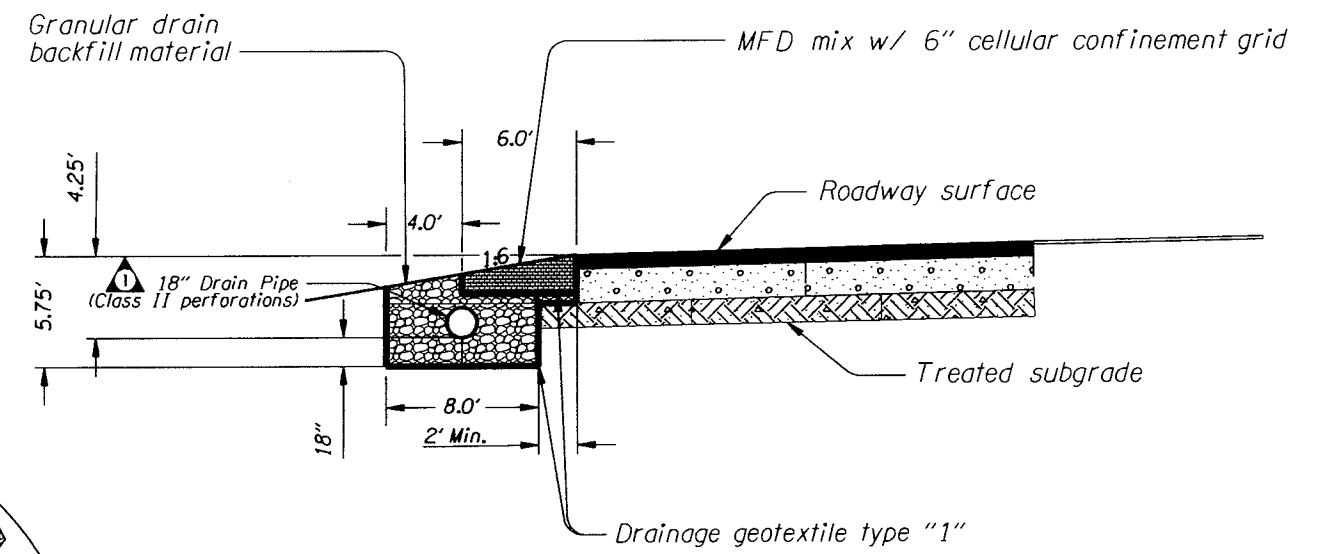
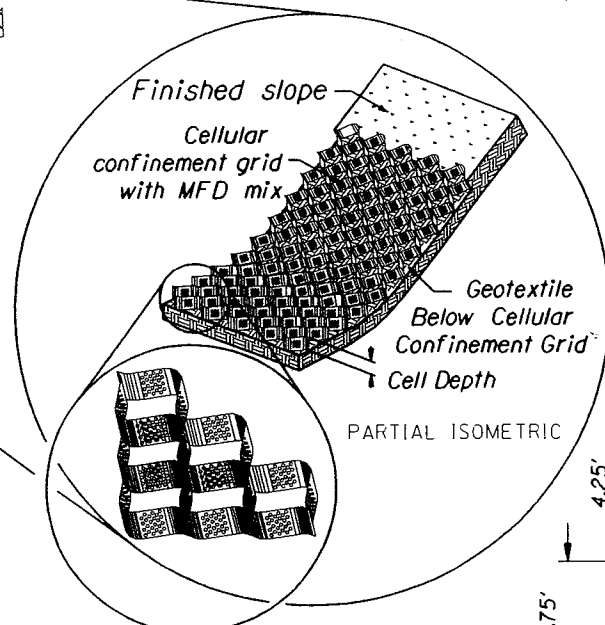

MFD (TYPE 1) SECTION SLOPE CONFIGURATION

Horiz. Scale: 1"=10'
Vert. Scale: 1"=10'

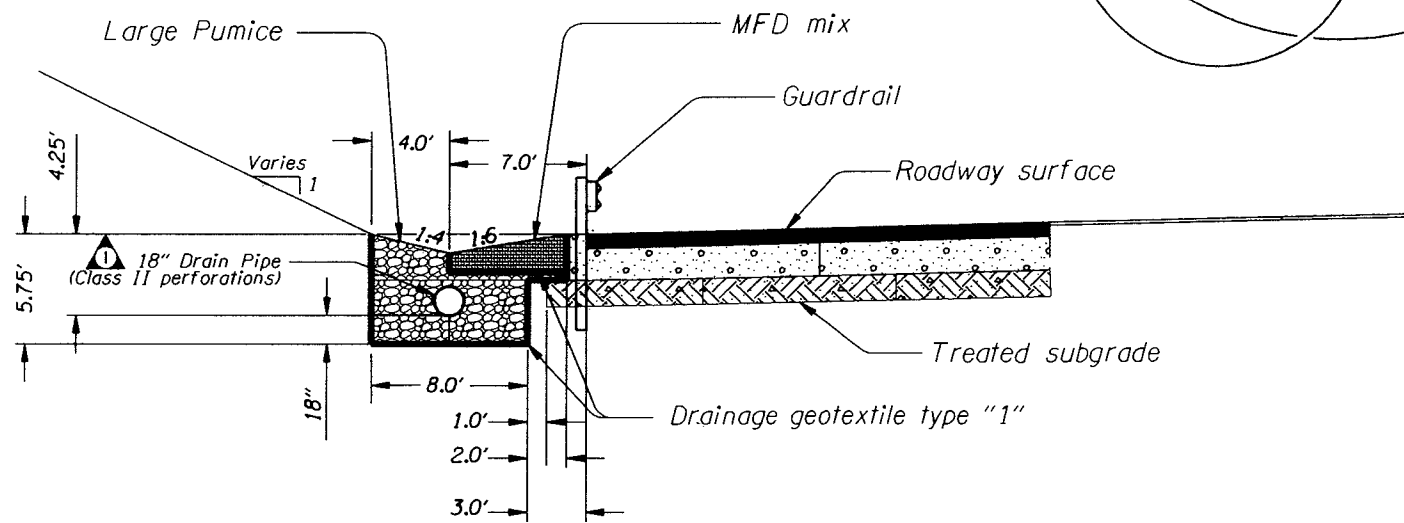

MFD (TYPE 2) SECTION DITCH CONFIGURATION

Horiz. Scale: 1"=10'
Vert. Scale: 1"=10'

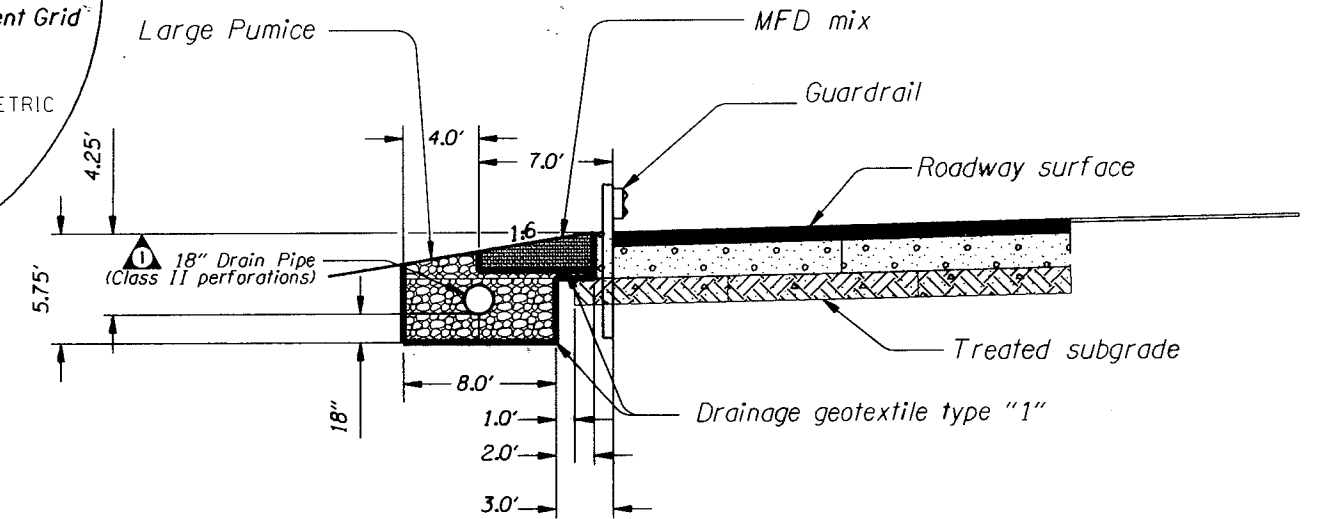

MFD (TYPE 2) SECTION SLOPE CONFIGURATION

Horiz. Scale: 1"=10'
Vert. Scale: 1"=10'

OREGON DEPARTMENT OF TRANSPORTATION

REGION 1 - GEO/HYDRO UNIT

US26: NW 185TH AVE - CORNELL ROAD SEC.
SUNSET HIGHWAY
WASHINGTON COUNTY

Reviewed By - Bruce Council
Designed By - Dan Gunther
Drafted By - Dan Gunther

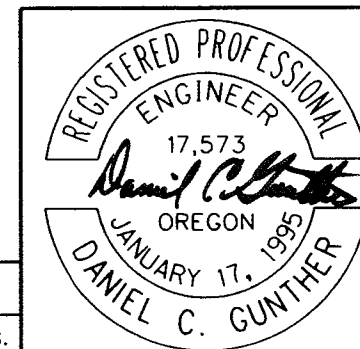

RENEWAL DATE: 6-30-2011

No.	DATE	REVISIONS	BY
1	04-01-10	Added drawing insert	D.C.G.
2	04-01-10	Added pipe callout	D.C.G.

WATER QUALITY DETAILS SHEET NO. GJ