

**CONCRETE ENCASEMENT DETAIL**

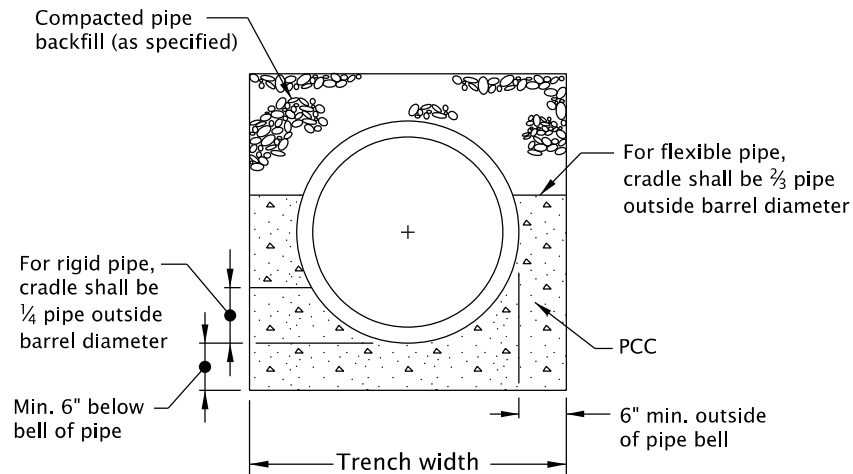

**CRADLE DETAIL**

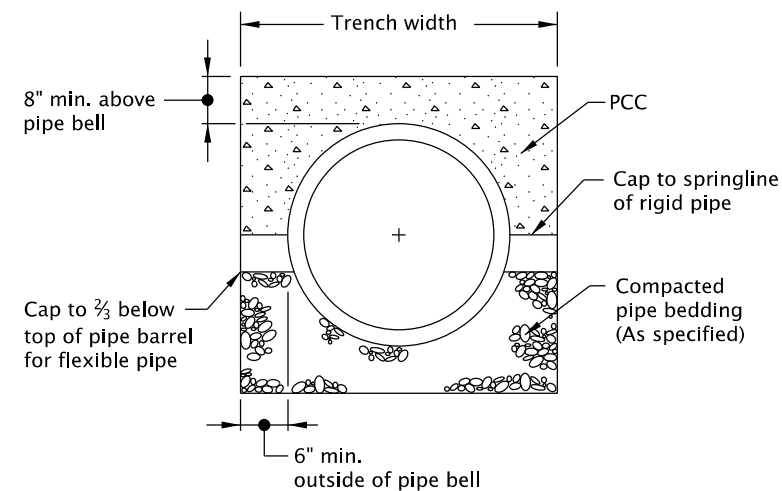

**CAP DETAIL**

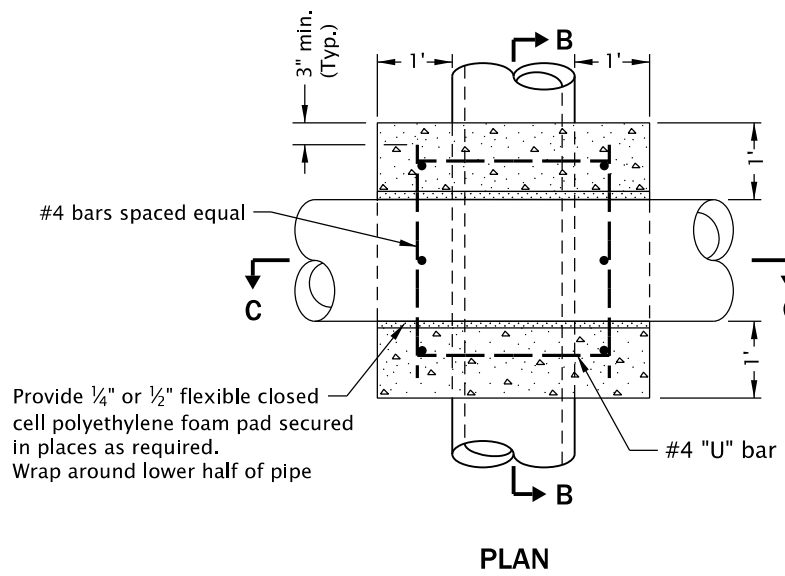

**PLAN**

**SADDLE**

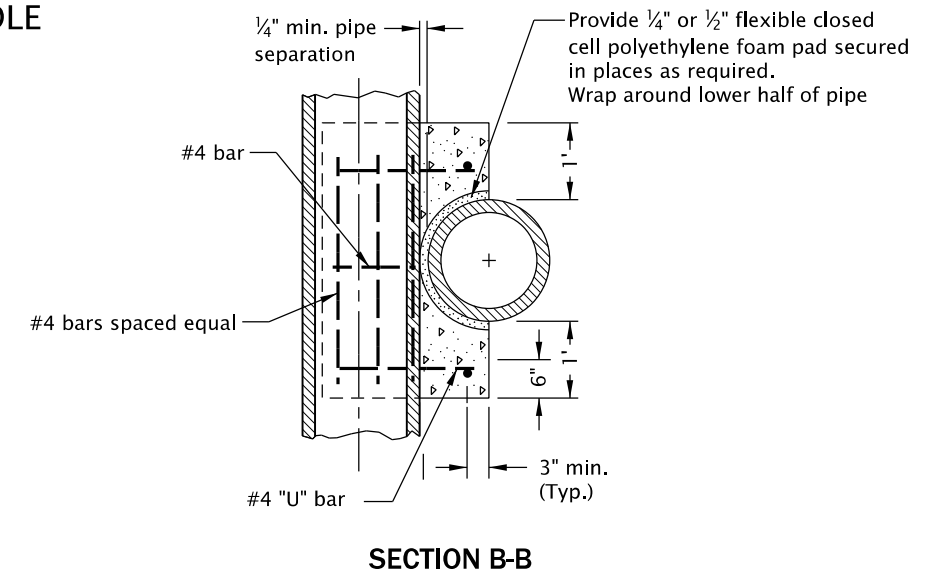

**SECTION B-B**

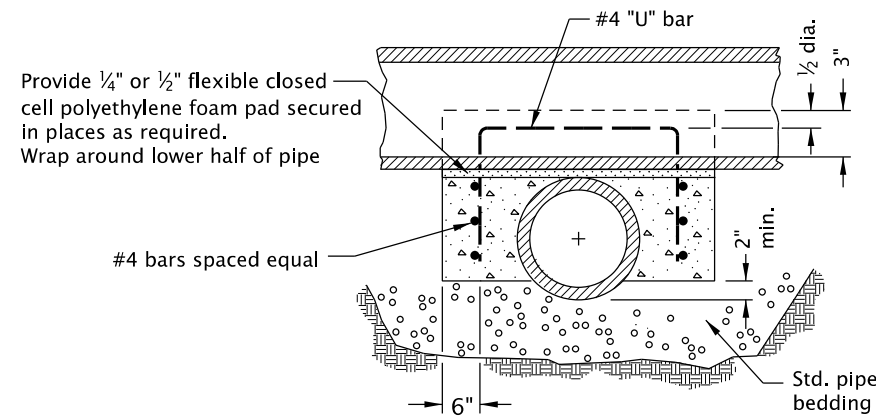

**SECTION C-C**

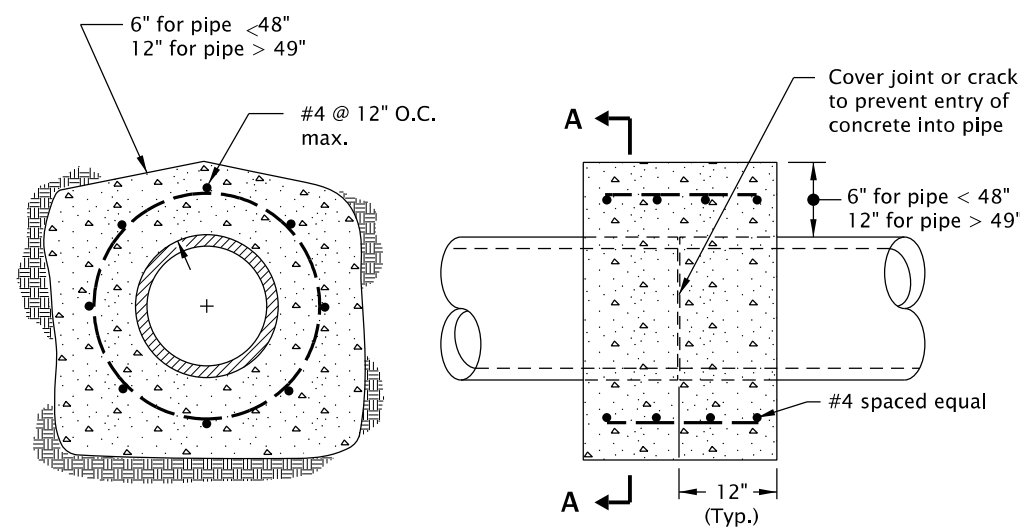

**SECTION A-A**

**PLAN**

**REINFORCED CONCRETE COLLAR**

**GENERAL NOTES FOR ALL DETAILS ON THIS SHEET:**

1. All concrete shall be commercial grade concrete.
2. End all reinforcing 3" clear of ground, forms or top surface, unless otherwise shown.
3. Trowel finish top surface of saddle, and cradle.
4. Reinforcement shall be # 4 vertical & horizontal bars as shown.
5. See Std. Dwg. RD300 for trench backfill, bedding, etc.
6. See Std. Dwg. RD336 for tracer wire details (When required).
7. Pipe over 72" diameter are structures, and are not applicable to this drawing.

CALC. BOOK NO. N/A

SDR DATE 14-JUL-2014

NOTE: All material and workmanship shall be in accordance with the current Oregon Standard Specifications

**OREGON STANDARD DRAWINGS  
CONCRETE ENCASEMENT,  
CRADLE, AND CAP DETAILS**

2021

DATE	REVISION	DESCRIPTION

*The selection and use of this Standard Drawing, while designed in accordance with generally accepted engineering principles and practices, is the sole responsibility of the user and should not be used without consulting a Registered Professional Engineer.*