



Over-Dimension Permit Application Guide

Use this guide when calling in permit requests to the Over-Dimension Permit unit at 503-373-0000 or ordering permits on [Oregon Trucking Online](#).

Depending on the commodity to be hauled, the following information will be required to process an over dimension permit. Questions may be asked out of the order as they appear below.

Please note, if your request requires route approval from a county or other road authority, your permit may be delayed.

Applications are worked in the order they are received.

Carrier and Vehicle Information

CCD Account Number

Contact the CCD Registration Unit at 503-378-6699 if you do not know your number, to get an account number or to get information on Oregon tax and registration requirements.

Contact Name and Phone Number

Include both should we have any questions about the application.

Email Address (optional for called in requests)

An email notification is sent when the application has been submitted and when it has been assigned to an analyst. This email includes the permit number and the name of the analyst assigned to the permit. Permits ordered on Oregon Trucking Online will also receive an email when the permit is completed. Completed permits can be emailed to one or more addresses.

Move Request Date

This is the date the permit is to begin. Single-trip permits are normally effective for 10 days, but may be less due to construction, maintenance, or other special provisions. All single trip permits must expire within 14 days.

Vehicle/Power Unit Information

Be prepared to provide the year, make, VIN, plate and unit number for your vehicle. Most times, we can find your information with just the plate and state, but have the other information available in the event we are not able to locate your truck in the system.

How Many Trips / Vehicles

Carriers have ability to list multiple trips and/or vehicles on an over dimension permit. Please note, a fee will be assessed for each trip or vehicle. Carriers may ask for an "Option of Vehicles" when it is unknown which specific truck is going to be used, but this must be clearly requested. Carriers may also request to use an "Equipment List" for certain permit types.

Send to Location for the Completed Permit

We currently are able to fax, email or send permits to your TOL account. In some cases, we may be able to send the permit to another ODOT office, but those locations are limited. Permits ordered through TOL will default to TOL as the Send to Location.

How to Pay

Eligible carriers can elect to charge the permit to their account or pay by credit card, when the permit has been processed. Charged permits will appear on statements (RUAF report for heavy haul permits over 98,000 lbs) mailed the following month.

Load and Dimensions

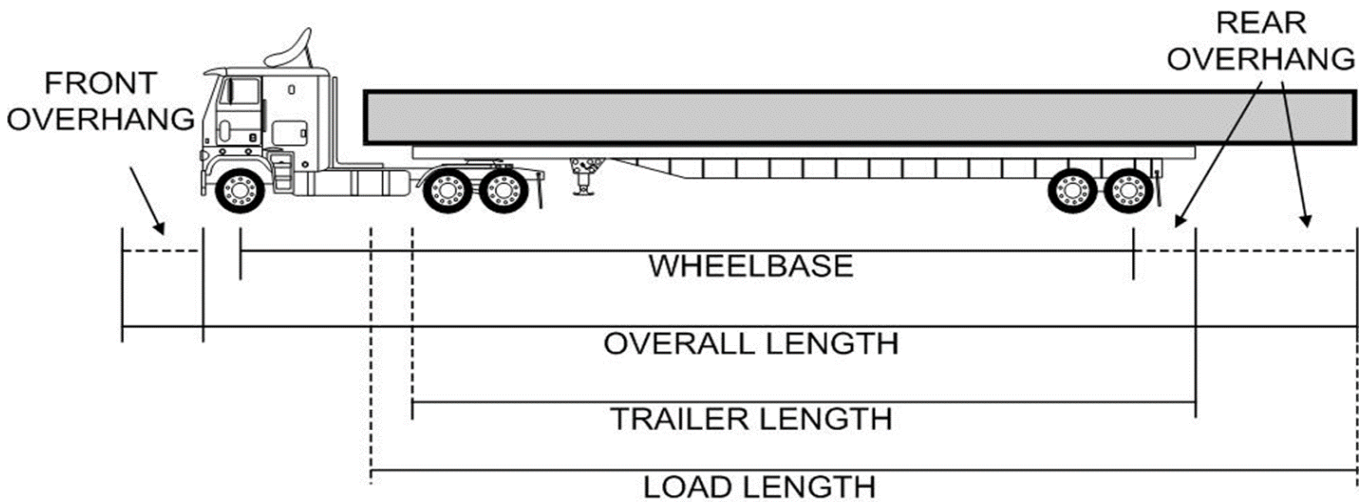

Commodity

The specific item being transported (such as log loader, air handling unit, poles). Non-divisible loads (such as dozer) with a part of the equipment detached (such as the blade) and reloaded (to reduce width) must be declared on the permit. Specific information is required, terms like "lumber" or "logging equipment" will need additional clarification.

Load Length

The length of the load being transported measured from extreme end to end at the longest point.

Width

The extreme width of the load measured at the widest points.

Height

The height of the load, measured from the ground to the highest point, loaded and ready for transport.

Overall Length

The total overall length of the hauling equipment including the load and any overhangs. For a self-propelled unit, such as a mobile crane, the overall length is the same as the load length.

Front Overhang

A permit is required if the load on the trailer extends forward of the rear of the cab of the power unit. Permits cannot be issued with both excessive front and rear overhang.

Rear Overhang

Enter the overhang as measured from the center of the last axle of the vehicle or combination of vehicles to the extreme end of the load. A load up to 5 feet from the end of the semitrailer is legal in Oregon. The amount of rear overhang for a non-divisible load extending more than 5 feet beyond the rear of the semitrailer must be specified on the permit.

Permits cannot be issued with both excessive front and rear overhang.

Description of Hauling Equipment

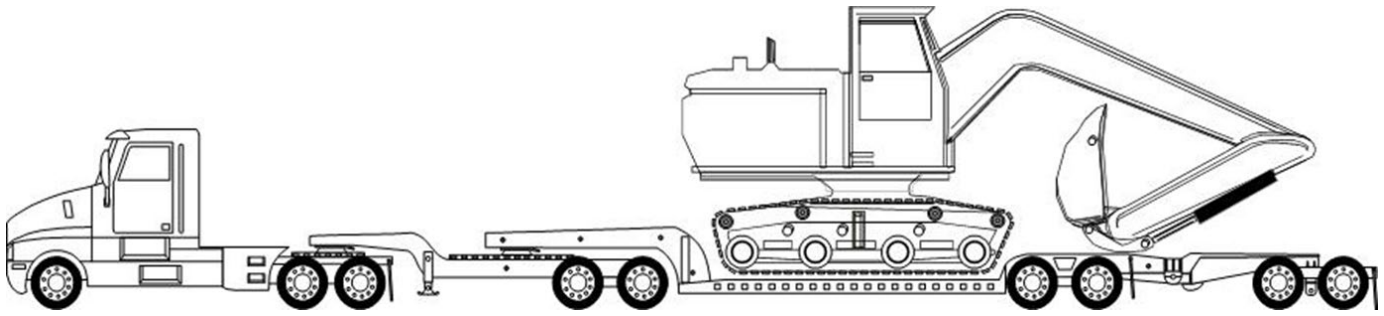

Description of Vehicles

A description of the hauling equipment being used, i.e.: truck-tractor and semitrailer, truck and trailer, etc. Other examples include 3-S2 for a 3-axle truck-tractor and 2-axle semitrailer, or 3-J2-S2-B2 for a 3-axle truck-tractor with a 2-axle jeep, 2-axle semitrailer, and 2-axle booster.

Trailer Length

The trailer length. Trailers exceeding 53 feet (or other length limits on certain highways) may be permitted on a case-by-case basis, depending on certain circumstances (mainly in a heavy haul combination).

Trailer Type

- **Fixed** – if the trailer is not reducible in length. Fixed trailer length of more than 53 feet is only allowed if flip axles(s) are deployed, a flip neck extension is deployed, or pinned axle(s) are added.
- **Stretch** – if the trailer is capable of increasing the distance from the kingpin or coupling device to the rearmost axle. This is accomplished by using a "telescoping" principle in the trailer. This does not include fixed or sliding extensions to either end of the trailer with removable deck sections.
- **Expanded** – if the trailer can be extended in length by adding removable deck section(s). In addition, flip axles(s) deployed, flip neck extension deployed, or pinned axle(s) may be allowed.
- **Special Use** – if the trailer is specifically designed to haul one type of commodity.
- **Tow-Away** – all equipment or tools mounted on wheels designed for towing by a motor vehicle, and which is not designed or used primarily for the transportation of persons or property but is only incidentally operated or moved upon a highway.
- **Flip Axle(s)** – an axle that is bolted or pinned to a vehicle and flips from the closed position on the trailer to a deployed position on the ground extending the length or hauling capacity of the trailer.
- **Flip Neck Extension** – a gooseneck extension to the front of a trailer which can be flipped up or down and can be used to adjust the axle weight(s) of a combination and load.
- **Pinned Axle(S)** – a separate vehicle pinned to another vehicle adding extra carrying capacity to a vehicle. The additional axle(s) do not pivot from side to side at the connection point or have wheels that steer during turning.
- **None** – If no trailer is part of the permit request (i.e. for solo vehicles, or fixed-load vehicles).

Trailer Width

Trailers wider than 8 feet 6 inches wide approved only on a case-by-case basis.

Weight

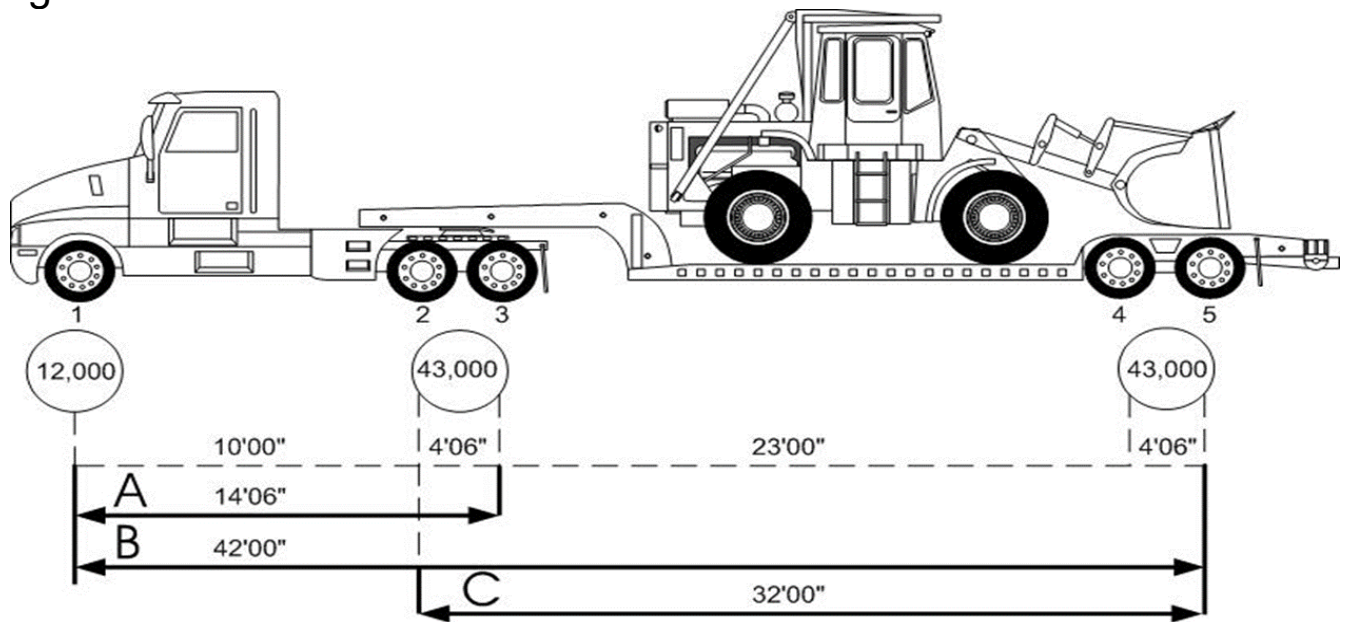

Gross Weight

The total combined weight inclusive of the load and vehicle or combination of vehicles.

Weight Table

Weight Table is the weight allowed over a given set of axle spacings. All axle and group axle weights must conform to a weight table for the permit to be valid - violations may result in enforcement action. Some bridges and roads may be restricted to a specific weight table. If you do not know which Weight Table your load conforms to, please leave this field blank and complete the axle spacing and weights section.

[Online Weight Analysis Calculator](#)

Additional information about Weight Tables can be found on our [Legal Vehicle Dimensions](#) web page.

If you have any additional questions about Weight Tables, please contact 503-373-0000, Option 1. We are available Monday through Friday between the hours of 7 a.m. and 5 p.m. Pacific time, closed on state holidays.

Number of Axles

Enter the total number of axles on the vehicle or combination of vehicles. When operating under Weight Table 3, 4, 5, or X, all available axles must be deployed.

Axle Width

For certain permits, axle width is required information for all superloads, even if the load is legal width.

Routing

Start Location

The specific location where the load is starting or entering Oregon. We will need the city, address, intersection and/or mile point.

End Location

The specific end location where the load will terminate or exit Oregon. We will need the city, address, intersection and/or mile point.

Requested Route

The route you wish to travel. Include the names of all county, or other, roads leading to or from the state highway system. The route may be changed by ODOT due to size, weight, or other road restrictions.

Unladen Travel

If the hauling equipment exceeds legal parameters for the route - you may need an unladen return or unladen travel to next destination.

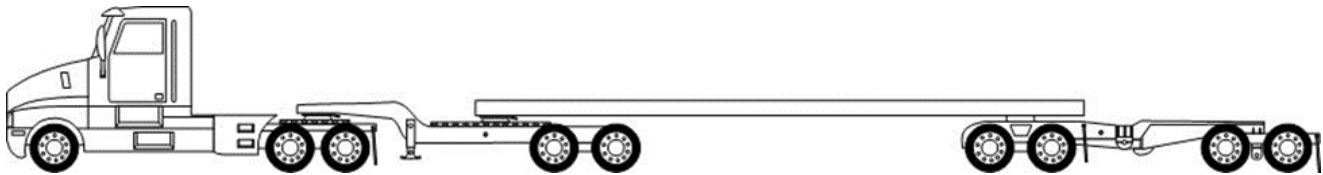

Mobile Units / Modular Buildings

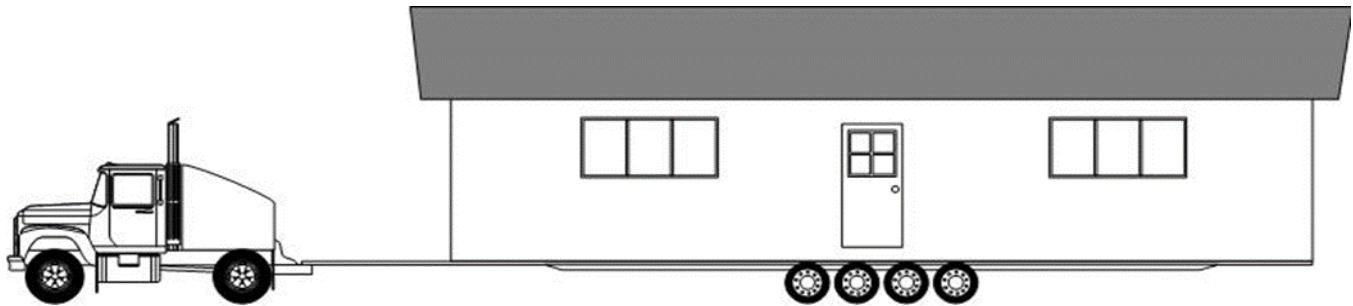

When ordering permits for either a mobile unit or modular building, additional/separate questions will be asked. Additional questions will include:

Base Width

Base width of the mobile unit including all appurtenances, but excluding eaves. A mobile unit base width greater than 16 feet is not allowed in Oregon.

Eave Width

Indicate eave width, if any. If there is an eave on each side, add the eaves together for total eave width.

Overall Width

The total width of base and any eaves combined.

Serial Number

The serial number of the manufactured/mobile home or modular building. Each piece should have an individual number or letter designation.

Building / Land Use Permit Number

Enter the building or land use permit number. This is only required if delivering to certain county jurisdictions, such as Benton, Clackamas, Lane, or Linn County.