

Chapter 25

Contents

25 Automatic Traffic Recorder (ATR) plan 25-1

25.1 General..... 25-1

25.2 Design Responsibility for ATR Plans 25-1

25.3 Detection - General 25-1

25.4 Inductive Loops..... 25-2

 25.4.1 Loop Layout..... 25-2

 25.4.2 Lane & Loop Numbering 25-3

 25.4.3 Loop/Piezo Wiring Diagram..... 25-3

25.5 Piezoelectric Sensors..... 25-8

 25.5.1 Piezoelectric Layout..... 25-8

 25.5.2 Piezoelectric Wiring Diagram..... 25-8

25.6 Non-Invasive Detection 25-9

25.7 Junction Boxes, Wire Entrance, and Pavement Cuts..... 25-9

25.8 Unique Geometry Considerations 25-13

25.9 Conduit and Wiring..... 25-14

 25.9.1 Service Cabinet to Controller Cabinet Wiring 25-14

 25.9.2 Loop Wire and Loop Feeder Cable 25-14

 25.9.3 Piezo Cable 25-14

 25.9.4 Conduit..... 25-16

25.10 Controller Cabinet and Service Cabinet 25-16

25.11 Controller 25-19

25.12 Communication..... 25-20

25.13 Maintenance Pad..... 25-20

25.14 Anti-Vandalism Treatments 25-20

25.15 Standard Drawing and Standard Details 25-22

25.16 Specifications, Cost Estimates, Bid Items, and Construction Support 25-22

25.17 Drafting Standards..... 25-23

25.18 Design Approval, Drawing Numbers, and ATR Site Number 25-25

Traffic Engineering Section

Traffic Signal Design Manual – Automatic Traffic Recorder (ATR) Plan

25.19 ATR Cabinet Prints 25-26

 25.19.1 Page 1 – Cabinet Layout 25-27

 25.19.2 Page 2 – Terminations 25-28

 25.19.3 Page 3 – ATR Site Drawing 25-29

25.20 Example Plan Sheets 25-30

25 Automatic Traffic Recorder (ATR) plan

25.1 General

Automatic traffic recorder (ATR) stations are operated and maintained by the transportation systems monitoring unit (TSM unit). This chapter provides the design standards for stand-alone ATR installations.

There are a handful of existing ATR sites that are part of a traffic signal. These ATR sites are no longer allowed for new construction as they are difficult to maintain and disruptions to data collection are more likely to occur. These existing sites should be designed to the current standards contained in the chapter. However, if it is not feasible to separate the traffic signal and the ATR, work with the state traffic signal engineer and the TSM unit to determine the site-specific design needs.

25.2 Design Responsibility for ATR Plans

The signal designer is responsible for producing ATR plans for new ATR sites, replacing detection due to other project work, and upgrading existing ATR sites at the end of their service life at the direction of the TSM unit.

Existing ATR stations are often overlooked during scoping and design because the TSM unit is typically not involved in STIP project development. As such, the signal designer shall verify if the project limits include any ATR sites and if they will be impacted by the project work. Verification tools include the [ATR locations map](#) and the [ODOT TransGIS](#) (see section 25.18 for information on using the TransGIS tool). If an ATR site will be impacted, contact the TSM unit at 503-986-4147 or e-mail trafficcunts@odot.state.or.us to coordinate the design details and plan reviews.

25.3 Detection - General

ATR sites, depending on the type of data to be collected, use different forms of detection:

- Inductive loops only - for basic counting needs
- Inductive loops AND piezoelectric sensors (piezos) - for accurately collecting the full FHWA 13 vehicle classifications

Note that non-invasive detection (e.g., radar or video) and newer technologies are currently being tested and evaluated by the TSM unit. See section 25.6.

The TSM unit will provide direction on which form of detection is required at each site. If only loops are required, the design should accommodate the potential for a future installation of piezos as per section 25.7.

25.4 Inductive Loops

Loop detection works by measuring a change in inductance. When the loop wire is coiled and a current is applied to the coil, a magnetic field is produced. A vehicle entering the magnetic field causes the inductance of the loop to decrease which is then detected by the controller and ultimately used to determine vehicle length and speed.

25.4.1 Loop Layout

The standard ATR loop layout is described below and shown in Figure 25-1.

- 6-foot diameter round loop
- Two loops per lane, spaced 16 feet apart ($\pm 1''$)
- The loops in each lane are staggered 18 inches from the loops in the adjacent lane.

Figure 25-1 | Loop Detection Spacing

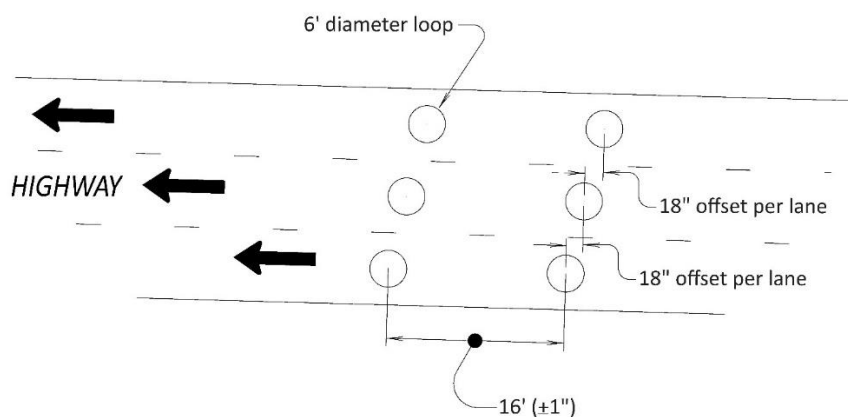

25.4.2 Lane & Loop Numbering

The lane and loop numbering are described below and shown in Figure 25-2:

- Lane no. 1 always starts with the WB or SB direction.
- Lane numbering starts at the outside lane for the WB or SB direction and then over to the outside lane in the other direction.
- Lead loops are always odd numbered and trail loops are always even numbered.

Figure 25-2 | Lane Line and Loop Numbering Example

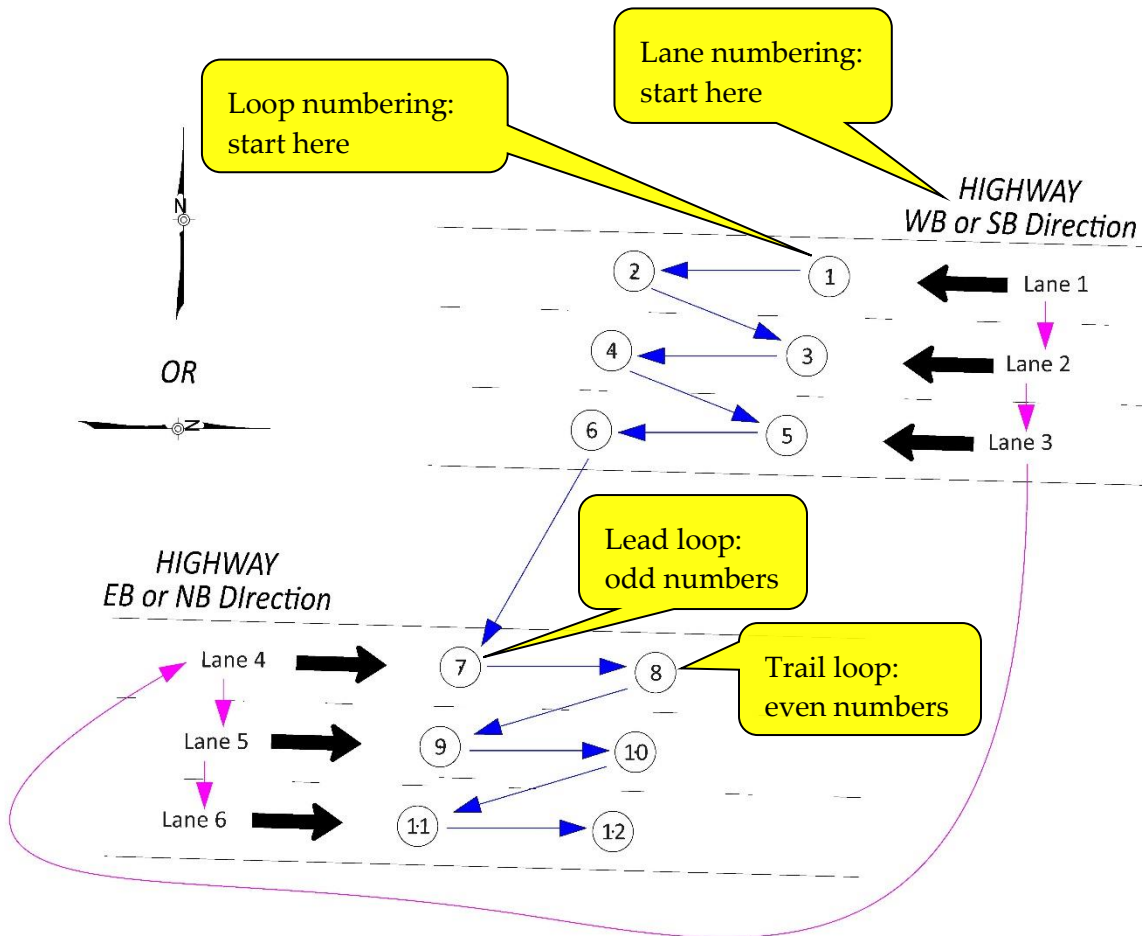

25.4.3 Loop/Piezo Wiring Diagram

The loop/piezo wiring diagram details the controller cabinet terminal block location for each loop and piezo. Starting with the left most column, the loop or piezo number is listed, followed by the lane number in the next column. The horizontal line for each loop/piezo after the lane number column represents the loop feeder cable/piezo cable for each loop/piezo which then

Traffic Signal Design Manual – Automatic Traffic Recorder (ATR) Plan

crosses the rectangle that represents the controller cabinet (e.g., loop feeder cable/piezo cable entering the controller cabinet). Each loop/piezo requires a separate loop feeder cable/piezo cable back to the controller cabinet. ATR loops/piezoes are never wired in series. Within the controller cabinet, the location where the loop feeder cables/piezo cables are terminated and the connection to the controller is shown. See Figure 25-3 for the standard wiring for a 332 cabinet and Figure 25-4 for a 332X cabinet. Note that the information shown in these two figures is specific to the loop/piezo number and does not change. The only modification needed to the wiring diagram is to delete the row(s) of loop/piezo numbers that are not on the project. For example in Figure 25-3, if the project has no piezos and a total of 8 loops, just delete the rows for loops 9 thru 16 and all piezo rows. These standard wiring diagrams are available on DET4480.

Figure 25-3 | Standard 332 Loop/Piezo Wiring Diagram

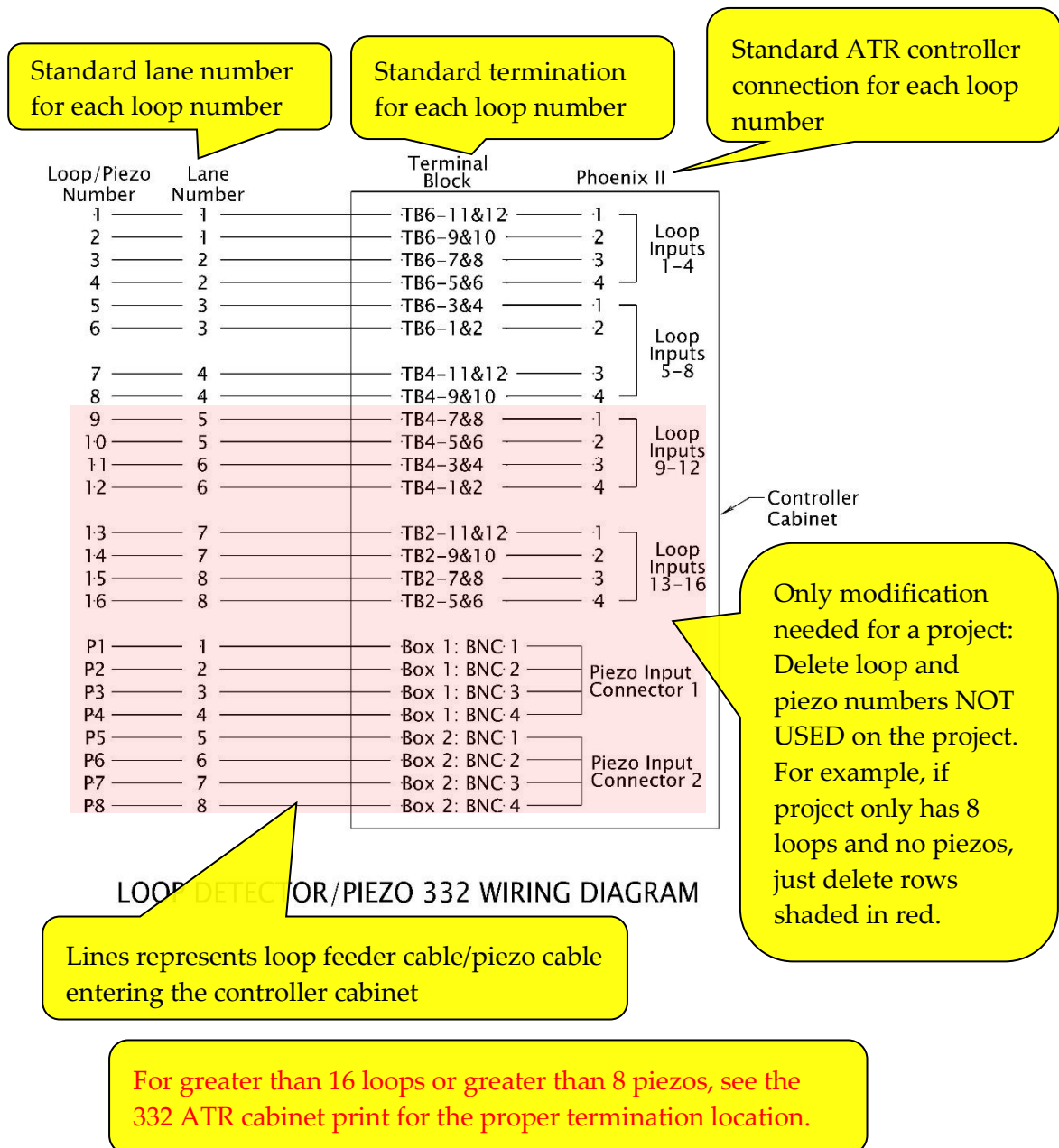

Traffic Signal Design Manual – Automatic Traffic Recorder (ATR) Plan

Figure 25-4 | Standard 332X Loop/Piezo Wiring Diagram

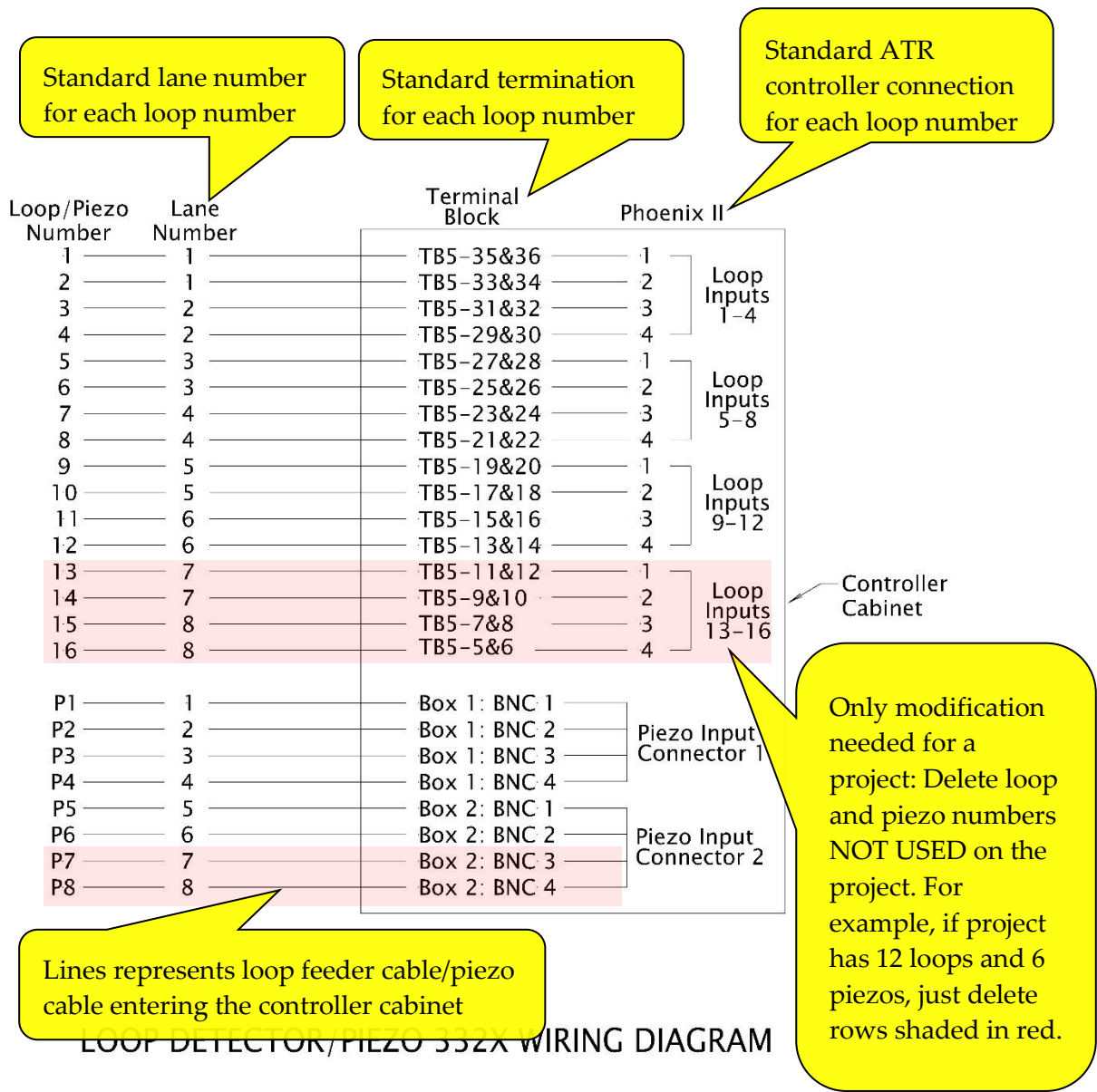

The standard loop terminations for the 332X match the 332 ATR terminations as they relate to the input file slot location (e.g., the input file slot location associated with each loop termination is consistent: 1 file, slots 2 thru 9). This allows for an easy transition/conversion to the possible future use of an ATC controller that uses the input file.

Traffic Signal Design Manual – Automatic Traffic Recorder (ATR) Plan

The loop/piezo wiring diagram is shown on the ATR plan sheet in its entirety, even if the project work doesn't include all of the loops/piezos. Loops/piezos that are to be retained and protected are labeled as "NO WORK" on the left side of the wiring diagram, either bracketed or directly next to the loop/piezo number. See Figure 25-5 for how to show no work areas on the wiring diagram.

Figure 25-5 | Showing No Work Areas in Loop/Piezo Wiring Diagram

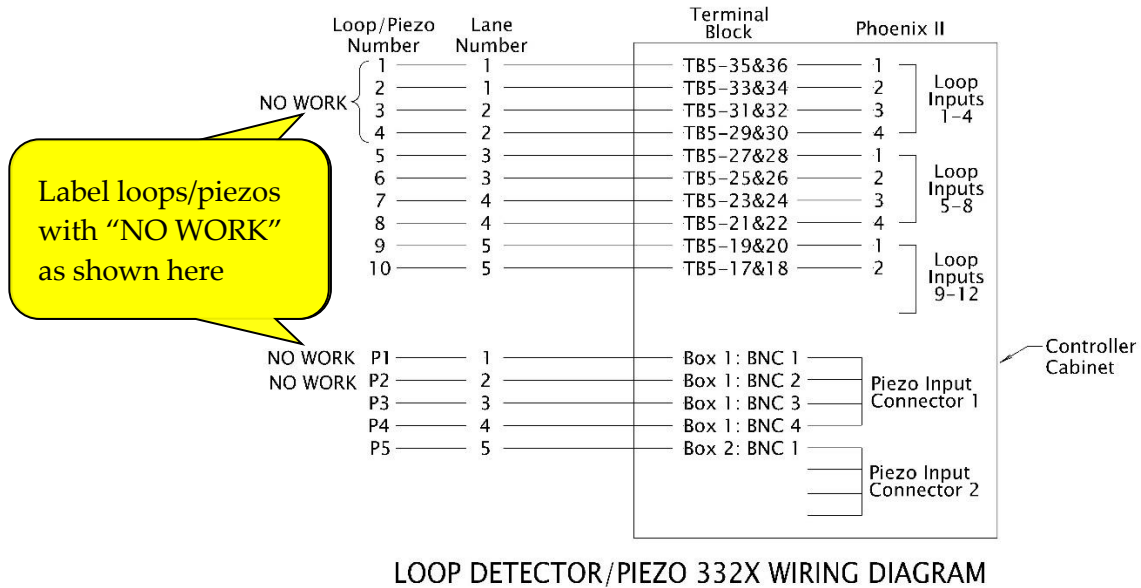

Traffic Signal Design Manual – Automatic Traffic Recorder (ATR) Plan

Splices are normally not used for the piezo cable (see section 25.9.3 for more information), but in the rare case where a splice is used, it will be shown on the plan sheets via the loop detector/piezo wiring diagram. See Figure 25-6.

Figure 25-6 | Piezo Splices Shown in the Loop/Piezo Wiring Diagram

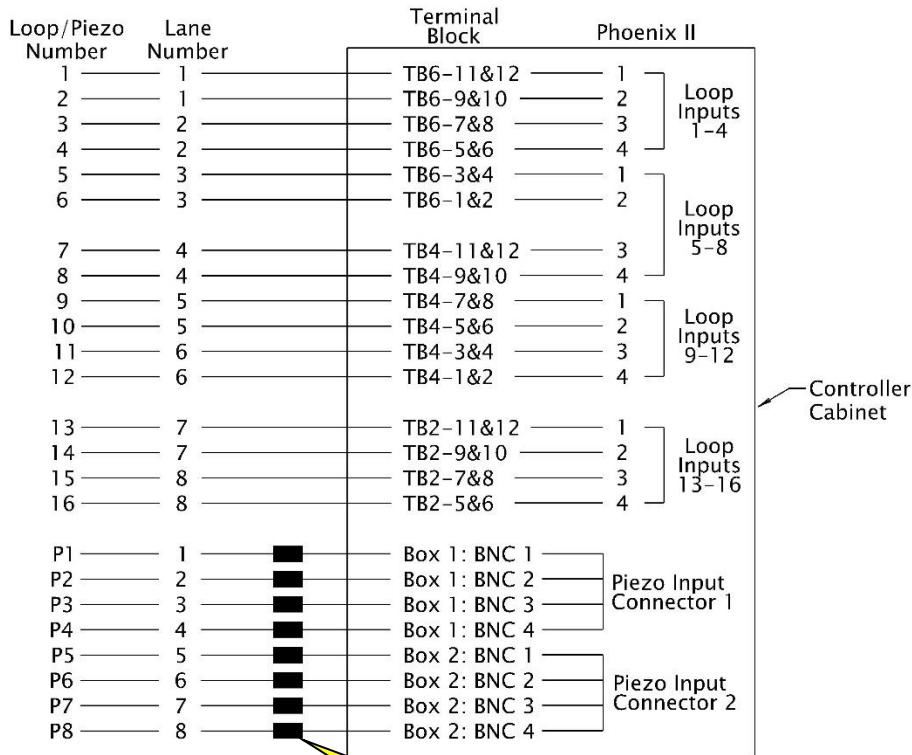

LOOP DETECTOR/PIEZO WIRING DIAGRAM

■ = Piezo Cable Splice

Piezo splices are shown with a filled-in rectangle for each cable that is spliced.

NOTE: splices should be avoided! If splices aren't necessary, these rectangles should be deleted.

25.5 Piezoelectric Sensors

Piezoelectric sensors (piezos) are used to sense each axle in a vehicle that passes over it. They work by producing a signal (voltage current) when an axle/tire comes in contact with them in the roadway. This signal pattern, which is unique to each vehicle configuration, is detected by the electronics in the controller. Using piezos in combination with loops results in the ability to gather additional data such as number of axles, axle length between individual axles, and overall axle length. It is currently the most accurate way to classify vehicles.

The decision to include piezos at a site is determined by the TSM unit.

25.5.1 Piezoelectric Layout

The piezo numbering and layout are described below and shown in Figure 25-7.

- Piezos are class II and 11 feet in length. They are a state furnished item.
- Piezos are centered between the lead loop and the trail loop (8' from the center of the loops). When the loops have been staggered according to section 25.4, the piezos in each lane also will be correctly staggered by 18 inches. This stagger is important for the piezo installation (downstream pavement cuts as per section 25.7) and to minimize crosstalk.
- Piezos are numbered according to the lane they are in (e.g., piezo 1 is in lane 1 and abbreviated as "P1").

Figure 25-7 | Standard Piezo Layout

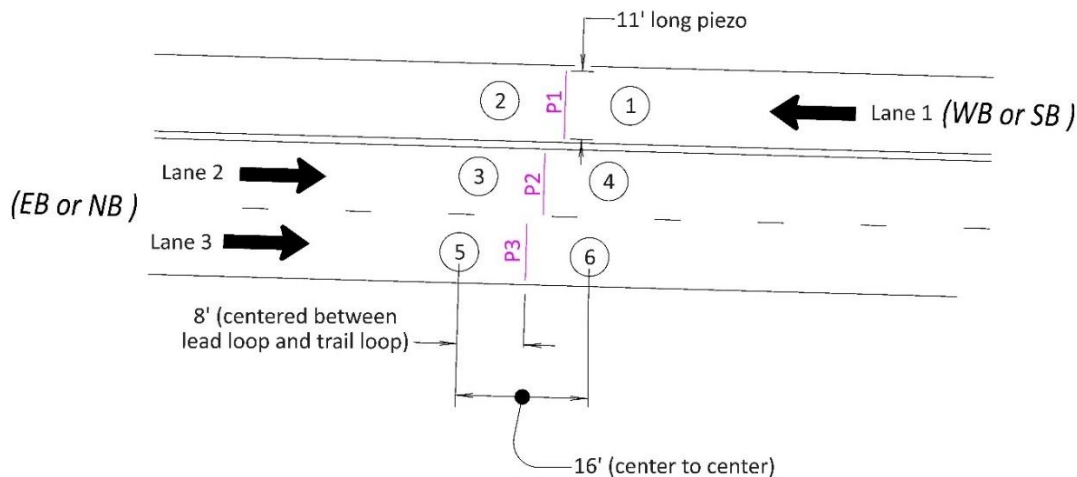

25.5.2 Piezoelectric Wiring Diagram

See section 25.4.3 for information on how the piezo wiring is shown.

25.6 Non-Invasive Detection

Cameras and radar detection devices are currently being evaluated by the TSM unit at a few trial sites. These are not the same devices used for traffic signal detection. They are typically complete systems from the manufacturer that includes a pole mounted controller cabinet with all the necessary circuitry and wiring. Follow the manufacturer's recommended installation. This is a state furnished item. Items that are not state furnished for this type of installation include:

- The pole (and pole foundation) that the camera and controller cabinet are mounted to. Typically, the mounting height required by the manufacturer will result in a luminaire pole (without the luminaire arm). However, a pedestal may be used to mount the radar as per TM457 if the required mounting height can be accommodated. A 3'x3' concrete pad next to the pole foundation where a person would stand when opening the controller cabinet should be provided. The luminaire pole and foundation should follow the requirements of TM629 thru TM635 and specification 00962.
- The service cabinet. See section 25.10.
- Conduit and wiring from the service cabinet to the controller cabinet. See section 25.9.
- Conduit (typically contractor installed) and wiring (typically utility provided and installed) from the power source to the service cabinet. See chapter 5 for more information.

The detection zones and any other necessary software programming information are configured by the TSM unit and will be shown on the cabinet print, not the ATR plan sheet.

25.7 Junction Boxes, Wire Entrance, and Pavement Cuts

Junction boxes should be installed as per TM472. See chapter 5 for general information on junction box placement and design considerations.

A JB/3 size junction box should be used near the controller. A JB/2 size junction box should be used for the detection, next to the wire entrances (sand pocket as per DET4428).

A separate wire entrance (sand pocket) is used for each "line" of loops and each "line" of piezos. The conduit size for the wire entrance will be either 2" (accommodates 1 to 4 loops OR up to 30 piezo cables) or 2.5" (accommodates 5 to 8 loops). The pavement cuts for each "line" of loops are typically installed to the outside of the loop, leaving the space in between the loops for the "line" of piezos.

If the project only includes loops, install a wire entrance for the piezos that can be used in the future.

See Figure 25-8 for an illustration of the typical junction box, wire entrance and pavement cuts.

Traffic Signal Design Manual – Automatic Traffic Recorder (ATR) Plan

Figure 25-8 | Typical Junction Box, Wire Entrance, and Pavement Cuts

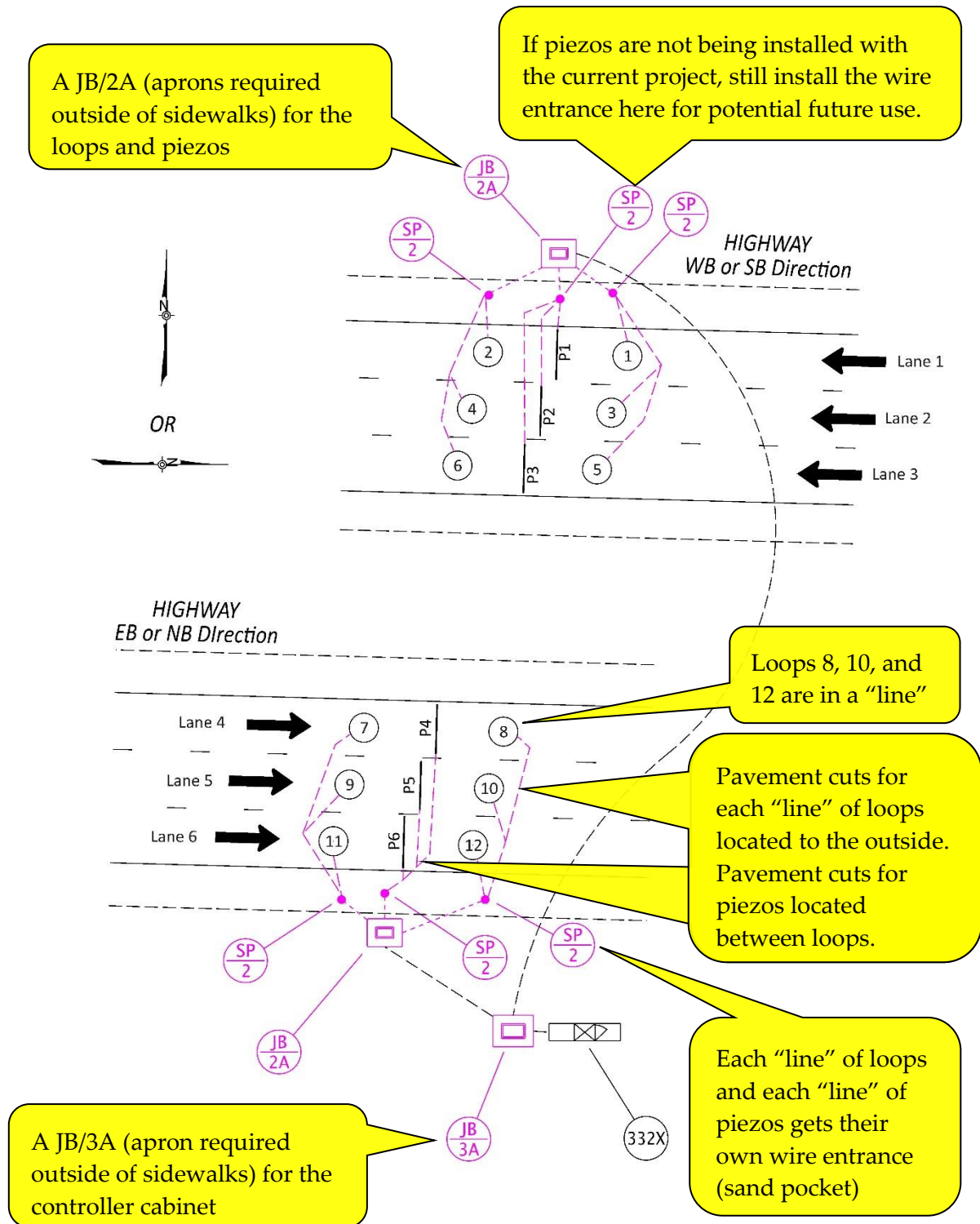

Traffic Signal Design Manual – Automatic Traffic Recorder (ATR) Plan

The default standard requires one junction box for each direction of travel. The junction boxes are located on the outside shoulders. Do not locate junction boxes in the median. When using a junction box for each direction of travel, the 18" stagger of detection to adjacent lanes applies to each direction separately (there is no need for line up the stagger for both directions of travel). See Figure 25-9.

Figure 25-9 | Default Junction Box Standard – One Junction Box for Each Direction of Travel

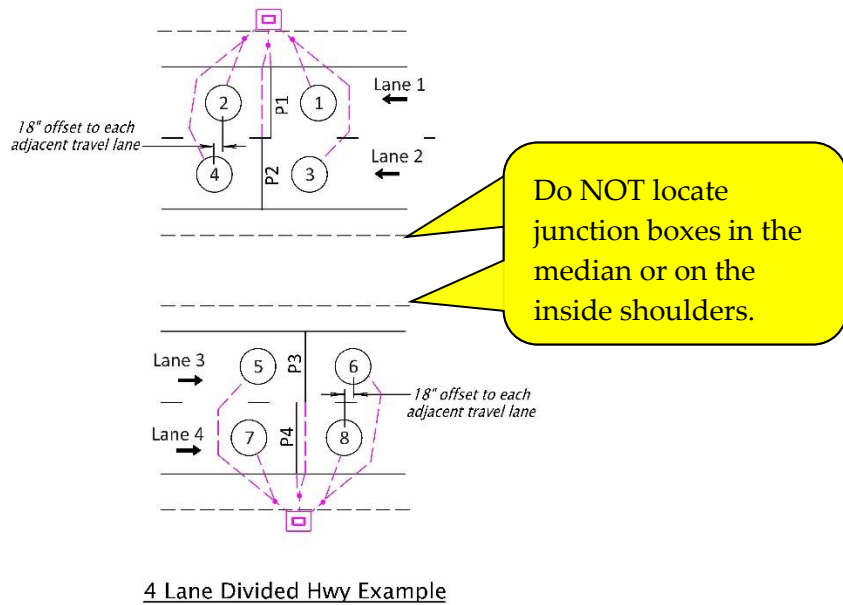
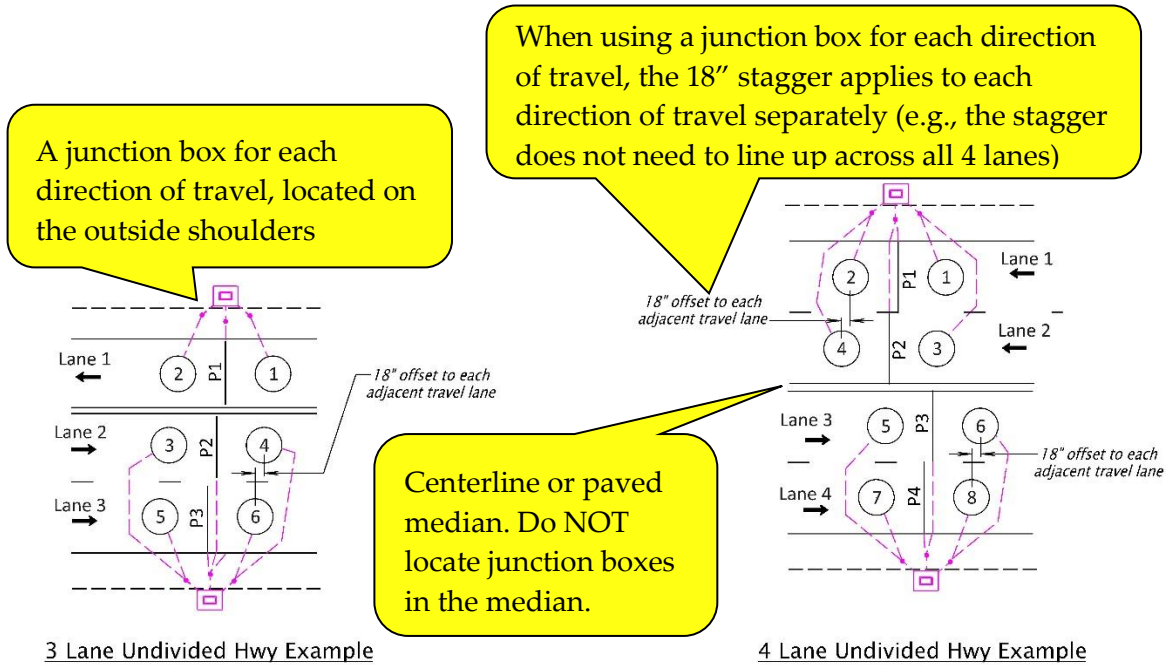

Traffic Signal Design Manual – Automatic Traffic Recorder (ATR) Plan

One exception to the default standard of providing one junction box for each direction of travel is for undivided highways where both directions of travel have just one travel lane. In this case, one junction box should be used for **both** directions of travel and it can be placed on either side of the roadway. The 18" stagger of detection to the adjacent lane is required. See Figure 25-10.

Figure 25-10 | Exception to Junction Box Default Standard – One Junction Box for Both Directions of Travel

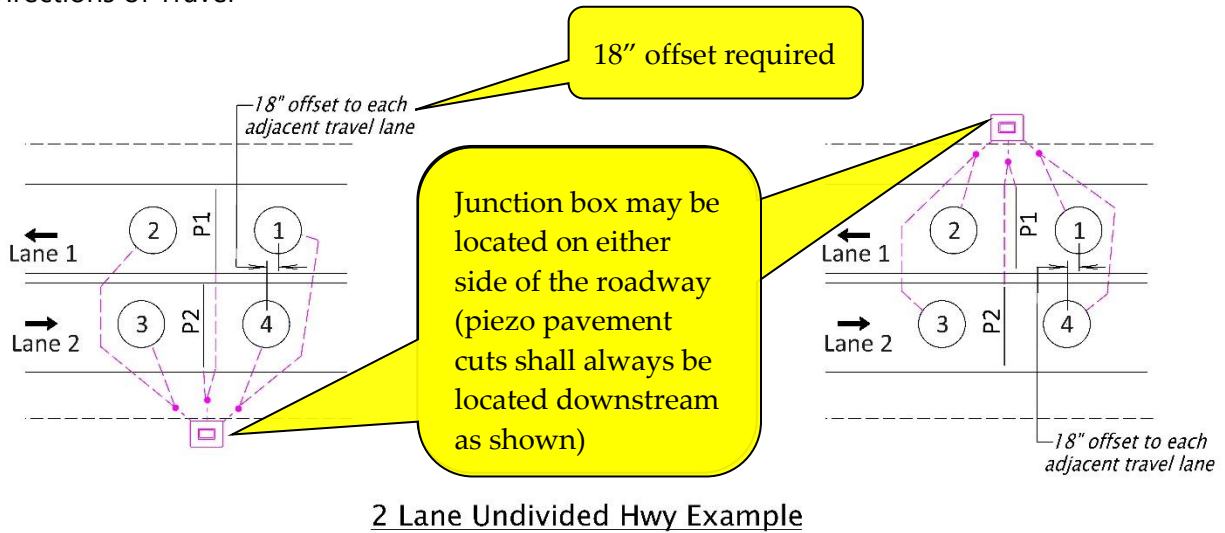

The location of the pavement cuts for piezos is very important. In addition to sensing an axle hitting the piezo itself, the piezo can also pick up the vibration of an axle hitting a nearby crack or pavement cut from a nearby piezo. The piezo is more sensitive to this kind of vibration when the crack is ahead of the piezo. For this reason, the pavement cuts from piezos are always placed downstream of the of the piezos nearer the sand pocket. Verify the stagger of the detection and placement piezo cuts (or future piezo cuts) will be correct. See Figure 25-11.

Figure 25-11 | Piezo Pavement Cuts Always Downstream

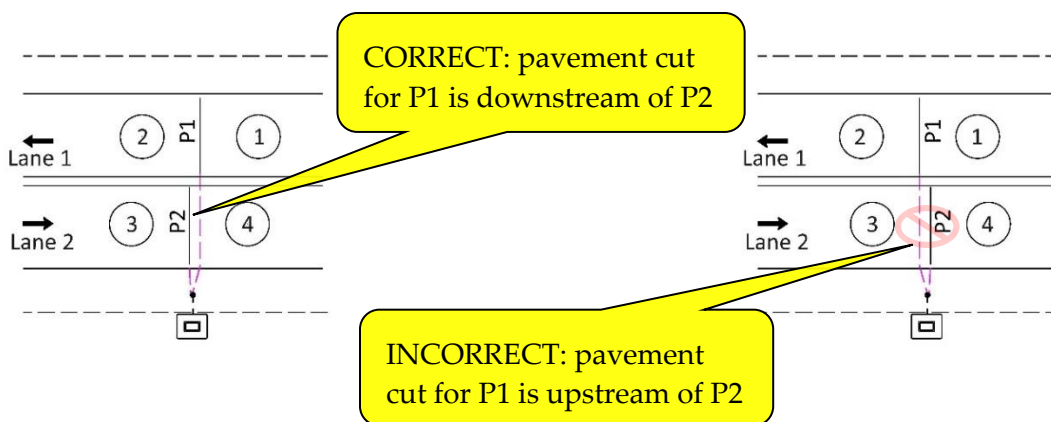

25.8 Unique Geometry Considerations

The previous sections of the manual show a very typical, standard ATR site lane geometry (e.g., two directions of travel, with the two directions of travel located on the same road surface or on two road surfaces separated by a standard median). However, there are various unique geometries (e.g., interchange configurations) that will require an ATR site where the standard ATR design guidance is either not applicable or requires some adjustment to meet the site-specific needs. See Figure 25-12. These unique geometries will require consideration of the project scope, data collection needs, initial installation costs, ability to maintain, and maintenance costs to determine the appropriate:

- Location for controller and service cabinets
- Location to install the detection (and the resulting type of detection). Note: on bridge decks, preformed loops during bridge construction or non-invasive detection are the only options. If possible, moving the detection location off of a bridge deck is preferred.
- Location of junction boxes and conduit

Figure 25-12 | Unique Geometry – Interchange ATR Example

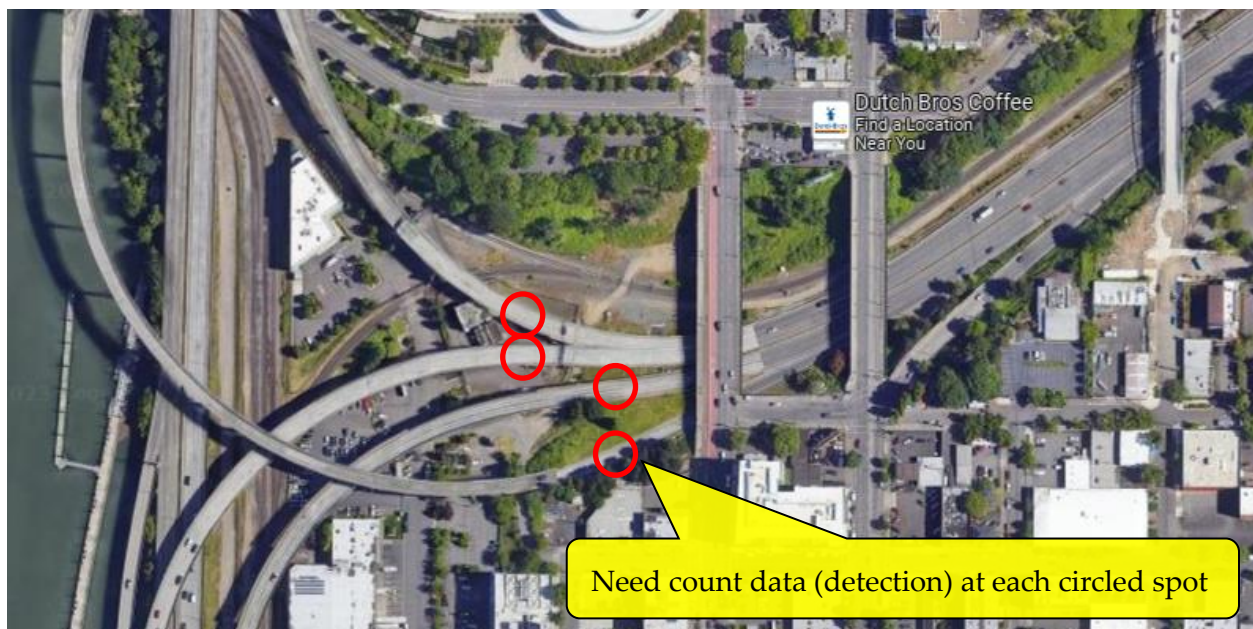

25.9 Conduit and Wiring

Conduit and wiring should be installed as per TM470 and TM471. See chapter 5 for general information on verifying the proper size of conduit and wiring.

25.9.1 Service Cabinet to Controller Cabinet Wiring

The default standard wire used from the service cabinet to the controller cabinet is No. 6 AWG XHHW wire. However, voltage drop must be verified for long runs of wire.

25.9.2 Loop Wire and Loop Feeder Cable

Loop wire is used in the pavement, with a standard of 5 turns of wire as per DET4428. Five turns of wire is adequate to provide the necessary change in inductance for any loops placed closer than 645 feet from the controller cabinet (measured from the circular loop edge, to the wire entrance, via the conduit to the controller cabinet, including slack wire), which should accommodate all ATR sites.

Loop feeder cable is used to connect the loop wire (in the pavement) to the controller cabinet. It consists of a polyethylene jacketed shielded twisted pair of No. 14 AWG wire. A smaller gauge loop feeder cable (no. 18 AWG) is also an option for use in retro-fits when the existing conduit cannot accommodate the standard no. 14 AWG cable.

All loop wire is spliced to a loop feeder cable in the junction box (not in the sand pocket). Loop feeder cables are continuous from the junction box all the way to the controller cabinet.

25.9.3 Piezo Cable

Piezo sensors come from the manufacturer with the cable (passive signal cable) already connected as splices are not recommended and should be avoided when possible. The standard piezo cable lengths available are 100, 150, 200, 250 or 300 feet. If the required length will exceed 300 feet (including the required slack as per TM470), contact the manufacture to determine the best solution. The contractor will field verify correct length to install.

The piezo cable is an RG-58 coaxial cable with an underground/direct burial rated outer jacket. The OD of the cable is 0.187 inches.

The piezo cable is terminated in the controller cabinet via a connector box with BNC connections. See Figure 25-13.

Figure 25-13 | Piezo Cable Connection in Controller Cabinet– Connector Box with BNC

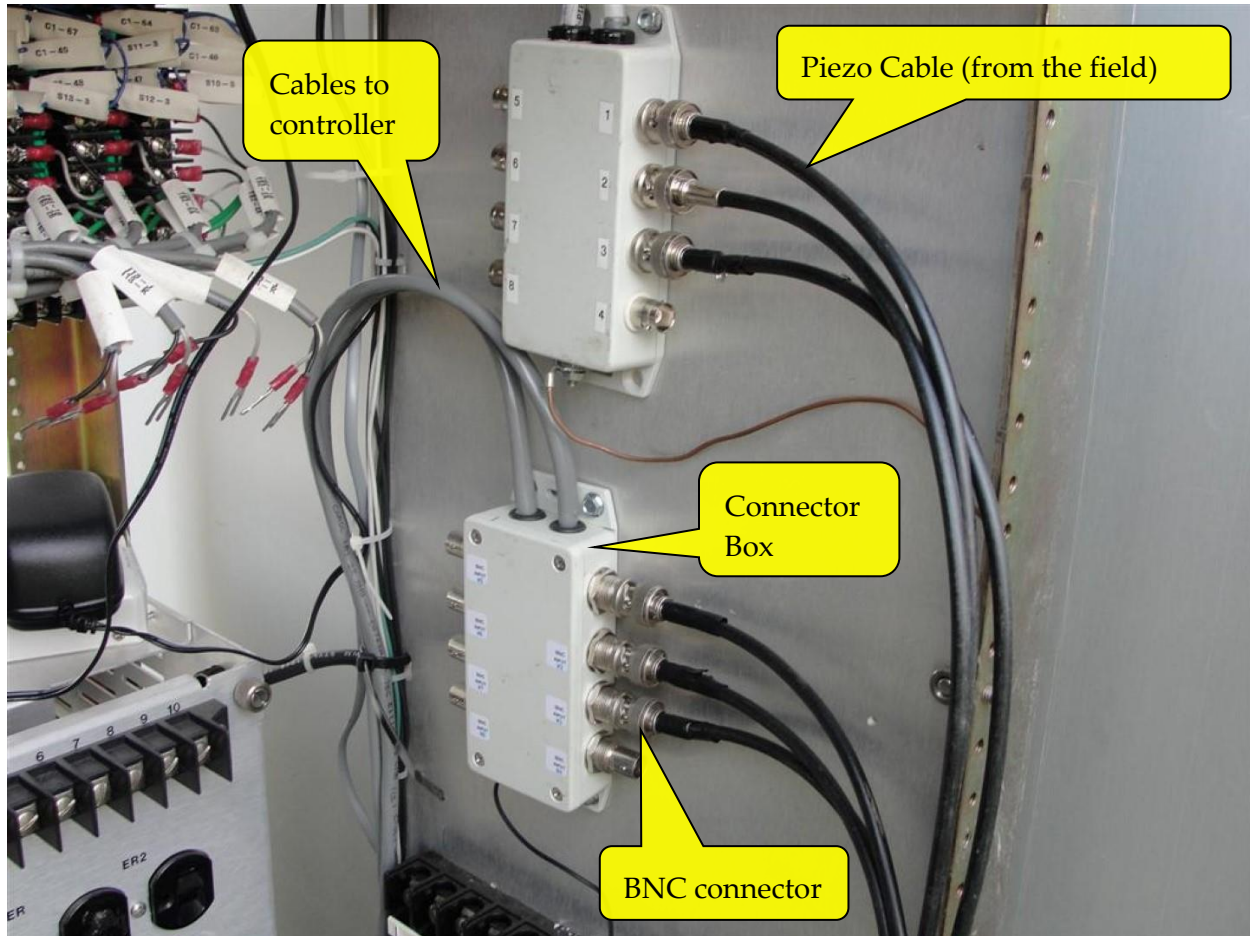

If a splice cannot be avoided, it will be done in the junction box (not the sand pocket) and it should be done according to the manufacturer's recommendations:

- The cable that is spliced to the cable attached to the piezo sensor should be the same cable as that supplied with the piezo sensor.
- Sealing should be done with an electrical sealing resin, such as 3M Scotchcast 2130. It is recommended that a splice kit such as a 3M 82-F1 Inline Splice Kit be used to provide the form for the sealing resin.

Piezo cable splices should be shown in the plans via the loop/piezo wiring diagram. See section 25.4.3 for example.

25.9.4 Conduit

The conduit requirements stated in chapter 5 apply to ATR installations. The TSM unit may request larger than the minimum conduit size depending on site-specifics and future needs. Figure 25-14 shows the ODOT minimum conduit sizes for the typical number of loop feeder cables and piezo cables installed. If the project happens to require cables/wires not shown in Figure 25-14, see chapter 5 for information on how to calculate the minimum conduit size.

Figure 25-14 | Loop Feeder Cable and Piezo Cable Allowed in Conduit

Typical Number of Loop Feeder Cable ("LF") + Piezo Cable ("P") in Conduit	ODOT Min. Conduit Size (See Chapter 5)
2 LF + 1 P	1 ½"
4 LF + 2 P	1 ½"
6 LF + 3 P	2"
8 LF + 4 P	2"
10 LF + 5 P	2 ½"
12 LF + 6 P	2 ½"
14 LF + 7 P	3"
16 LF + 8 P	3"
18 LF + 9 P	3"

A spare 2" conduit (with capped ends and a poly pull line) shall be installed from the controller cabinet to the first junction box (JB/3). This spare conduit will allow for easy access into the controller cabinet for future devices.

Avoid unnecessary conduit crossings of the roadway by placing junction boxes, the controller cabinet and/or the service cabinet on the same side of the roadway when possible.

25.10 Controller Cabinet and Service Cabinet

A 332X controller cabinet is standard (332S cabinet shell with ATR specific hardware configuration), unless using a complete system from the manufacturer (e.g., non-invasive detection as described in section 25.6). The controller cabinet should be located outside the clear zone in rural locations if possible or at the back of sidewalk in urban locations. It should also be located near the detection, with the louvered front door opening so that it will not block the view of roadway when a person is facing the front of the cabinet. See Figure 25-15 for example of proper controller cabinet orientation.

Figure 25-15 | Correct Orientation of Controller Cabinet

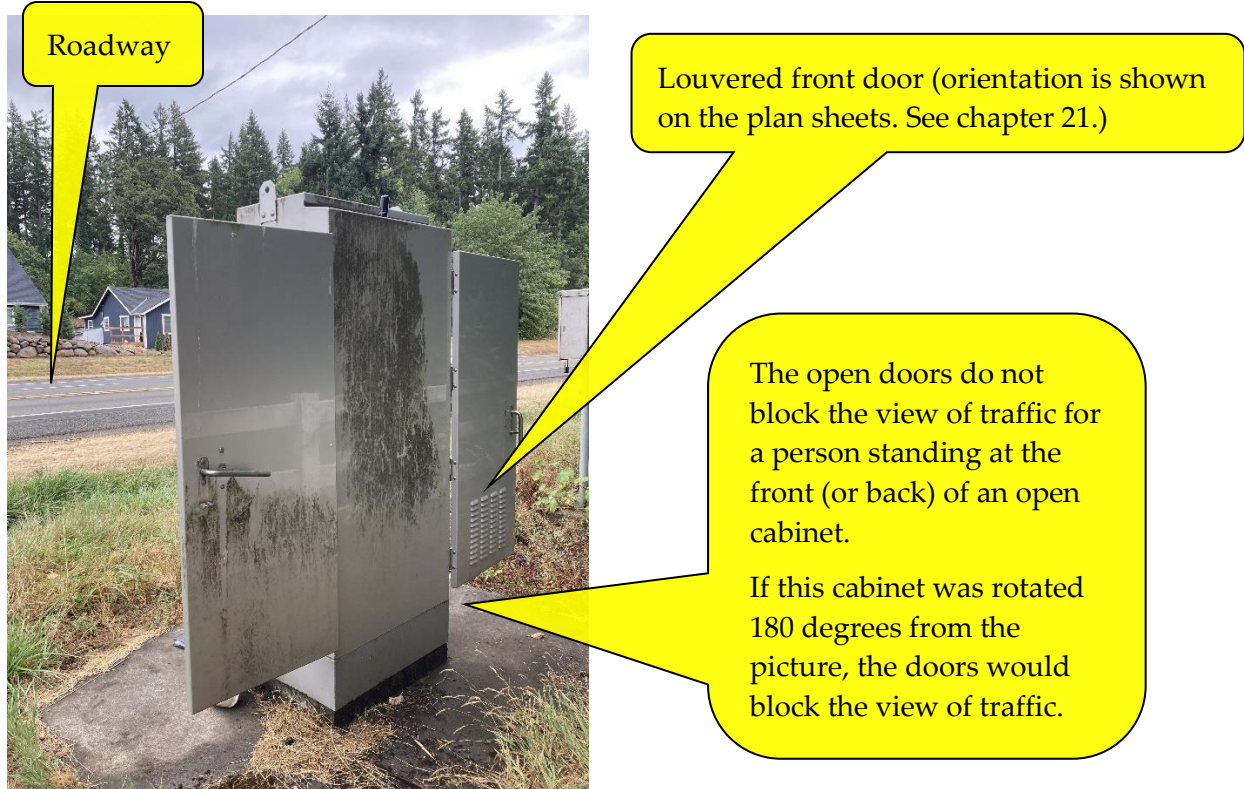

Other types of controller cabinets and service cabinets have been used in the past and may continue to be used if they are not at the end of their service life. If an existing controller or service cabinet is damaged or needs to be relocated, it shall be replaced with the current standard.

A base mounted service cabinet (BMC) is the standard service for ATR sites. If possible, it is ideal to place the base mounted service cabinet near the controller cabinet as shown in TM482 for ease of maintenance. However, this may not be possible in all locations. It is typical for the utility to have a maximum distance the service cabinet can be from the power source (e.g., approx. 50 feet). In rural locations, the nearest available power source may be several hundred to several thousand feet from the location of the ATR site. In these cases, the service cabinet will need to be placed according to the utility's requirements. Contact the region utility specialist to determine the requirements/constraints for placement of the service cabinet.

Note that TM482 requires a walkway from the edge of pavement to the both the controller cabinet and the service cabinet foundations. For rural locations, this needs to be shown on the plan sheets, as each walkway will be site-specific. See Figure 25-16 for example. Also, the standard 36" x 24" landing pads for the cabinet foundation on TM482 may be enlarged at the direction of the TSM unit to further discourage the surrounding vegetation from encroaching on the equipment in remote areas. This will require a custom detail in the plan sheets. See Figure 25-17 for examples.

Figure 25-16 | Rural Location Walkway to Controller Cabinet Example

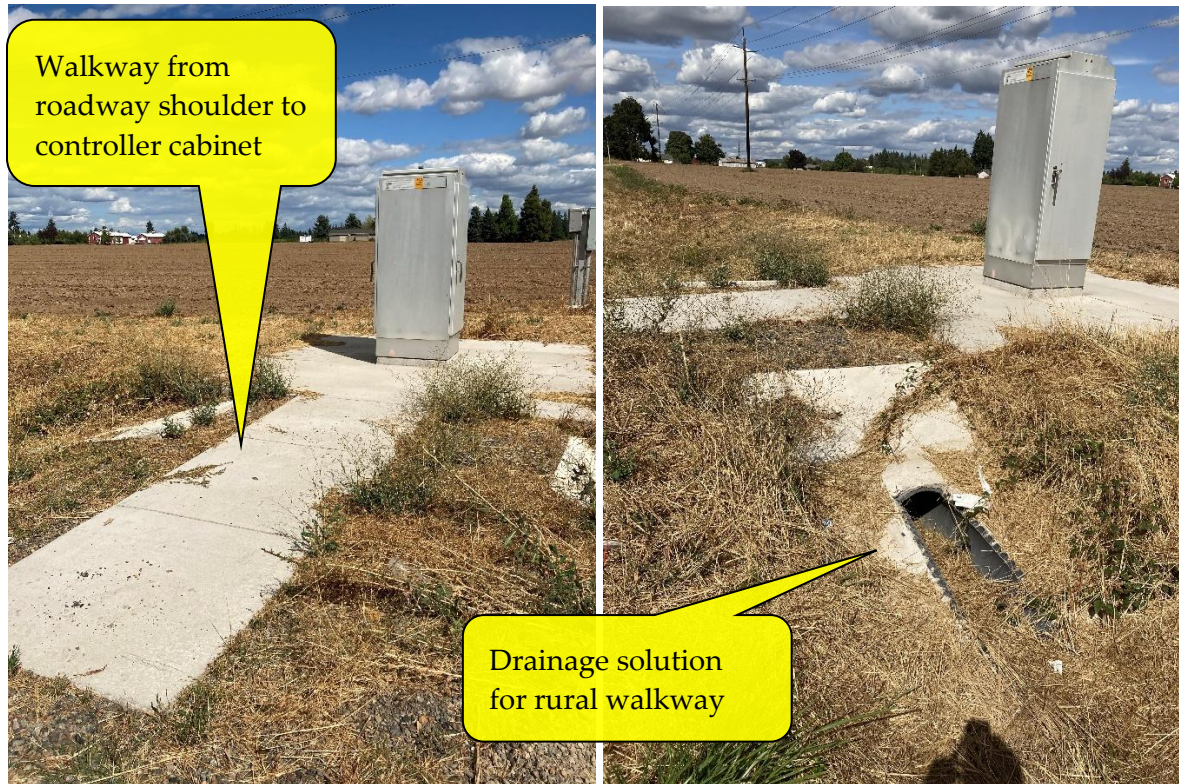

Figure 25-17 | Custom Controller Cabinet Landing Area Examples



25.11 Controller

The [phoenix II controller](#) is the standard controller for ATR sites. It can accommodate up to 16 loop detectors and 8 piezos. See Figure 25-18. If more loop detectors or piezos are needed, an additional Phoenix II controller will need to be installed in the controller cabinet. See Figure 25-19. The controller is a state furnished item.

If non-invasive detection is used, a manufacturer specific controller will be required. See section 25.6 for more information.

Figure 25-18 | Phoenix II Controller – Accommodates 16 Loop Detectors and 8 Piezos



Figure 25-19 | Two Phoenix II Controllers – Accommodates 32 Loop Detectors and 16 Piezos



25.12 Communication

Communication for ATR sites is not allowed on the state network. A modem is used with a site-specific private connection that will either be cellular (preferred if cell coverage is available in the area) or dial-up. The TSM unit will provide information on the proper communication plan and equipment needed for each site. The communication equipment is a state furnished item.

25.13 Maintenance Pad

The TSM unit will determine if a maintenance pad should be installed. See Figure 25-20. See chapter 5 for more information on maintenance pad use and design.

Figure 25-20 | ATR Site Maintenance Pad Example



25.14 Anti-Vandalism Treatments

Certain locations may require consideration of anti-vandalism treatments to better protect the controller cabinet and service cabinet. Fences, anti-graffiti coating, custom locking mechanisms, and/or custom fortresses may be necessary. See Figure 25-21 through Figure 25-23. The TSM unit will determine if any of these additional treatments are necessary.

Figure 25-21 | Anti-Vandalism Treatment – Fortress Example

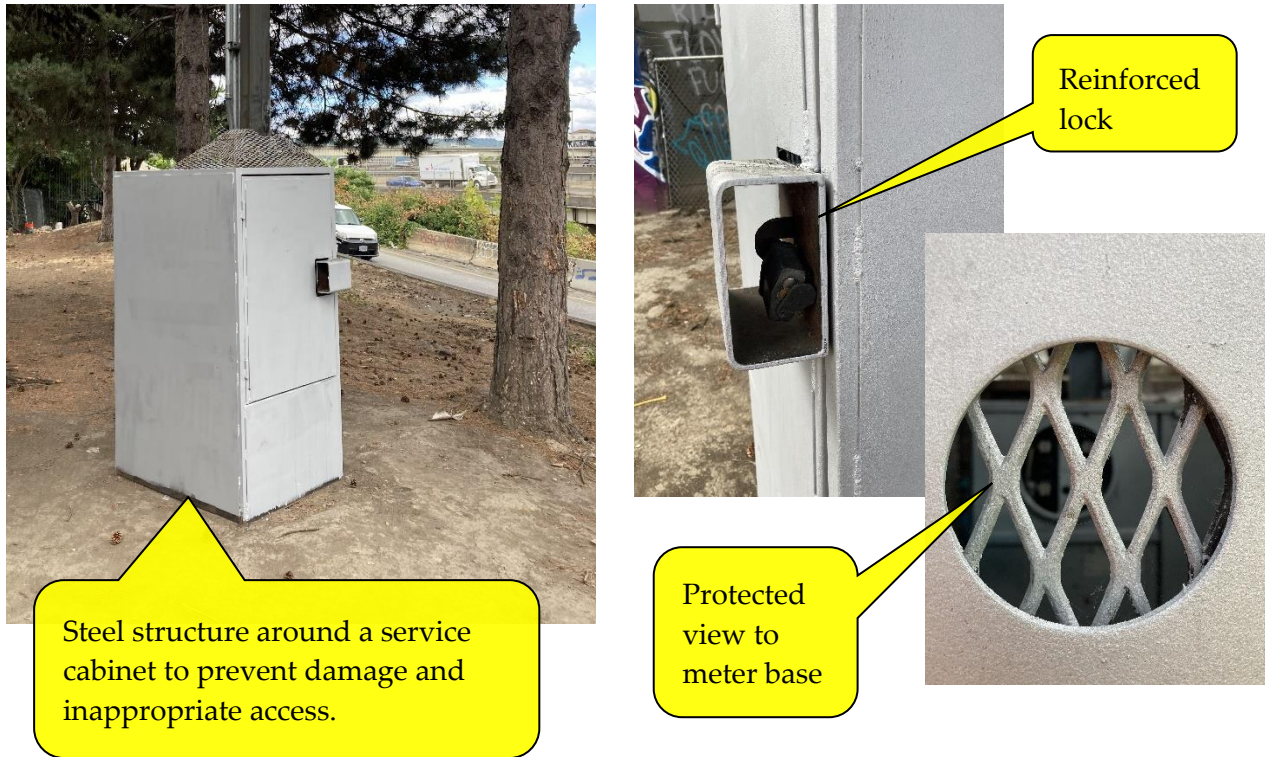
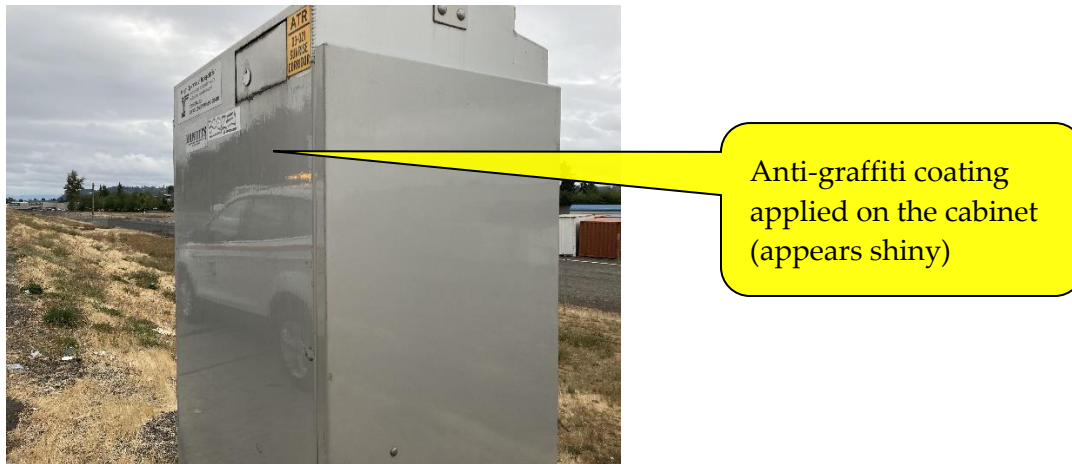

Figure 25-22 | Anti-Vandalism Treatment – Custom Locking Mechanism



Figure 25-23 | Anti-Vandalism Treatment – Anti-Graffiti Coating



25.15 Standard Drawing and Standard Details

The following standard drawings should be referenced for ATR work:

- TM470 for general wiring and cable installation notes
- TM471 for trenching and conduit installation
- TM472 for junction box installation
- TM482 for controller cabinet and base mounted service cabinet foundation
- TM485 for service cabinet wiring details

The following standard details should be used to create site-specific plan sheets for ATR work:

- DET4428 for general loop detection installation
- DET4480 for ATR drafting & wiring diagrams
- DET4481 for ATR typical layout details
- DET4485 for ATR Piezo details

25.16 Specifications, Cost Estimates, Bid Items, and Construction Support

The traffic signal cost estimate spreadsheet may be used for the majority of the items (e.g., conduit, junction boxes, wiring, etc.). The TSM unit will provide cost estimates for any state furnished items (e.g., piezos). State furnished items require a letter of public interest finding (LPIF) and are an anticipated item. See chapter 19 for information on the LPIF process and anticipated items.

Specifications 00960 and 00990, with special provision boiler plates should be used.

The bid item is in 00990, “Automatic Traffic Recorder Installation”, as a lump sum.

For additional information on specifications, cost estimates and bid items, see chapter 19.

The TSM unit will supply the state furnished items to contractor.

Figure 25-25 | DET4480 Drafting Content Example

NOTE TO DESIGNER: CHOOSE APPLICABLE NOTE(S) FOR PROJECT
General Notes:

1. Contact _____ at _____ for onsite observation and re-connection of counter equipment 48 hours prior to loop replacement
2. Install after permanent striping and rumble strips have been installed.

NOTE TO DESIGNER: Use the ODOT traffic signal workflow for all other standard bubble notes (JBs, conduit, controller cabinet, loop wire, loop feeder cable, sand pocket).

ATR specific bubble notes:

- (332X) Install a model 332S cabinet with ATR specific control equipment (see cabinet print) with riser frame, orient louvered door as shown
- (C PHC) Install model phoenix II count controller. (Agency furnished)
- (LD C) Install 6" round vehicle count loop as per typ. layout detail
- (LF X) Install (X=number of cables) function loop feeder cables
- (LF CON) Install spade type connectors, crimped and soldered, at the terminal end of each loop feeder cable
- (PZO) Install class 2 type 11' -0" long sensors as per typ. layout detail and according to manufacturer (Agency Furnished)
- (PZ X) Install (X=number of cables) piezo cables
- (PZ BNC) Install BNC type connectors at the terminal end of each piezo cable

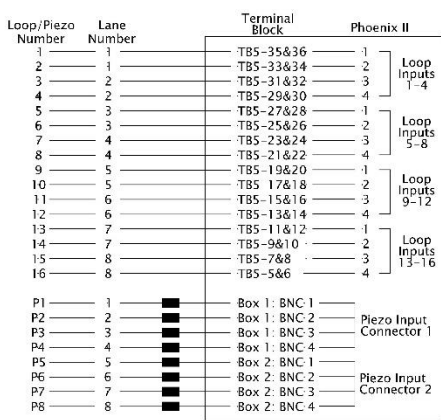

LOOP DETECTOR/PIEZO 332S WIRING DIAGRAM

■ = Piezo Cable Splice

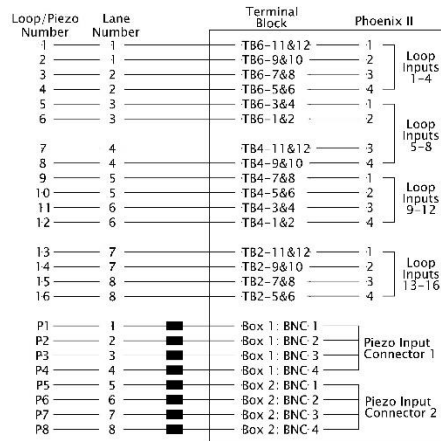

LOOP DETECTOR/PIEZO 332 WIRING DIAGRAM

■ = Piezo Cable Splice

NOTES TO DESIGNER:

1. Standard lane number and terminal block are shown for each loop number for the 322S and 322 cabinet. Delete loop numbers and piezo numbers not used.
2. Piezo cable splice should be avoided if possible. Delete purple splice info if piezo splices aren't used on the project

Standard details typically have instructions to the designer – follow them and delete them from final plan sheets.

25.18 Design Approval, Drawing Numbers, and ATR Site Number

ATR plan sheets do not require a design approval signature on the plan sheets, but the TSM unit shall review and concur with the design.

Each ATR related plan sheet is issued a unique drawing number (referred to as either “TRS drawing number” or “unit file code”) that is assigned by the traffic engineering section. See chapter 2 for the process to get the drawing number(s).

The ATR site numbers are assigned by the TSM unit for all ATR installations. This info is used in producing the various data reports for the [Transportation Volume Tables](#), maintenance, and asset management purposes. The format of the site numbers is 00-000 and is accompanied by a name (e.g., location description), for example “Monroe, 02-007”. For existing ATR sites, TransGIS can be used to determine the ATR site number and name using the “Traffic Data” layer which contains “Automatic Traffic Recorders”. See Figure 25-26.

Figure 25-26 | TransGIS ATR Layer

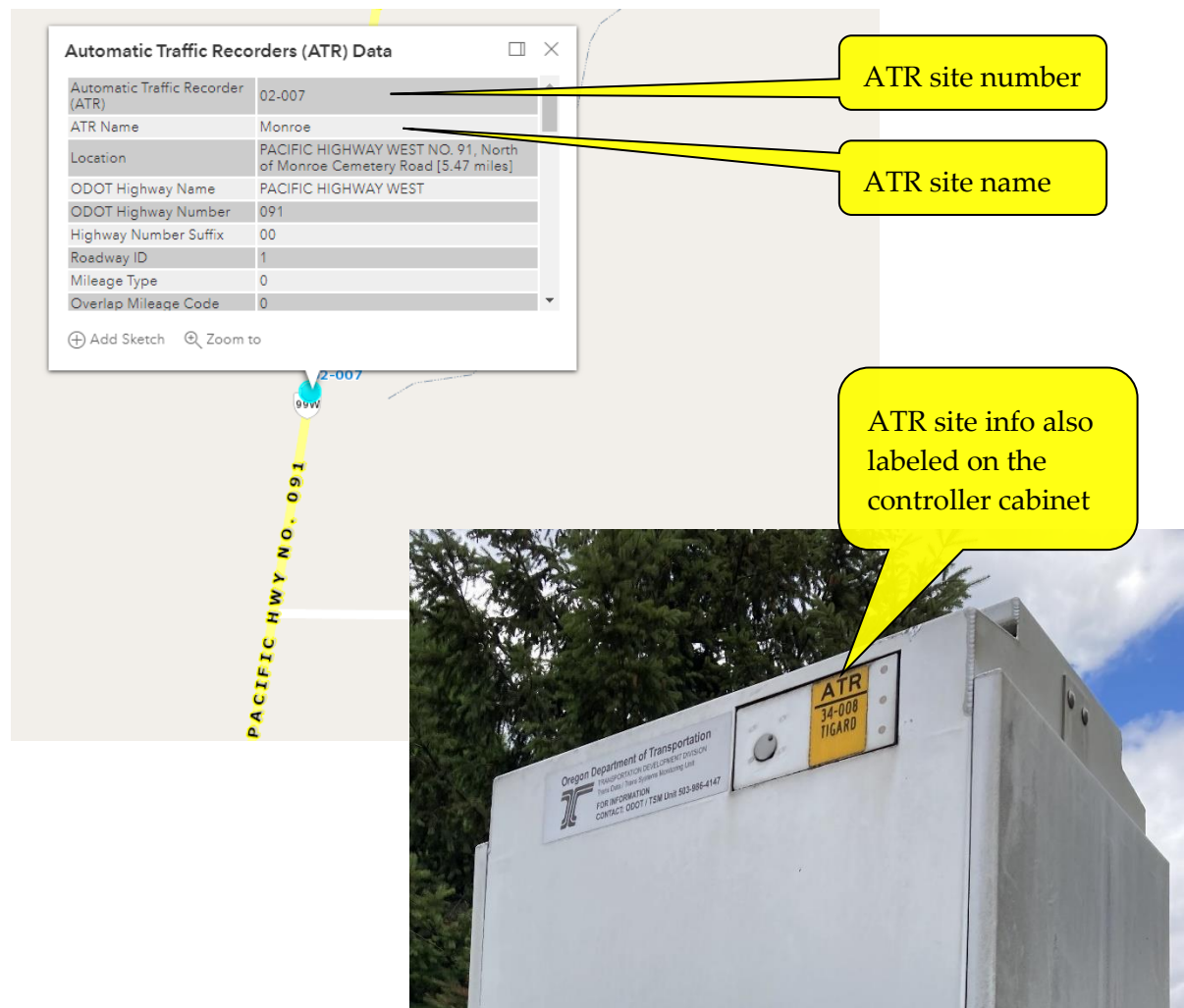

25.19 ATR Cabinet Prints

The cabinet print is a schematic representation of the components that are inside the controller cabinet. This schematic is used mainly by the TSM unit and electricians on-contract to perform maintenance. A hard copy of the cabinet print is required to be in the controller cabinet at all times. Cabinet prints must be accurate for proper maintenance of the ATR site and data collection.

The signal designer is responsible for creating the cabinet print(s) for the project. The cabinet print should be completed prior to PS&E, with review by the TSM unit. When completed, the MicroStation file and the PDF file of the cabinet print is sent to the TSM unit, where it is archived. The TSM unit is responsible for any updates to the cabinet print after the project (documenting changes made during maintenance work, correcting typos, etc.).

There are ATR specific Microstation base files for 332X (standard) or the 332 modified (to document existing ATR sites with a 332 cabinet) on the [traffic signal standards website](#). In the MicroStation base files, the areas that can be modified are typically shown in red. There are different levels that can be turned on or off depending on the equipment that is installed. Basic instructions for how to use and properly fill out the cabinet print will also be contained within the file.

Each ATR site should have its own cabinet print file. The file name should begin with the ATR site number followed by name, for example, “02_007_Monroe.dgn”

Cabinet prints are formatted for printing on 11x17 paper.

NOTE! All figures in this manual show a 332X cabinet. The cabinet print layout for the 332 will be slightly different, but all contain similar elements. The basic information in this manual can be used in conjunction with the appropriate base file.

25.19.2 Page 2 – Terminations

Page 2 of the cabinet print shows the terminations of the loop feeder cable and piezo cables. The only modifications necessary to this sheet are shown in Figure 25-28.

Figure 25-28 | 332X Cabinet Print (Page 2)

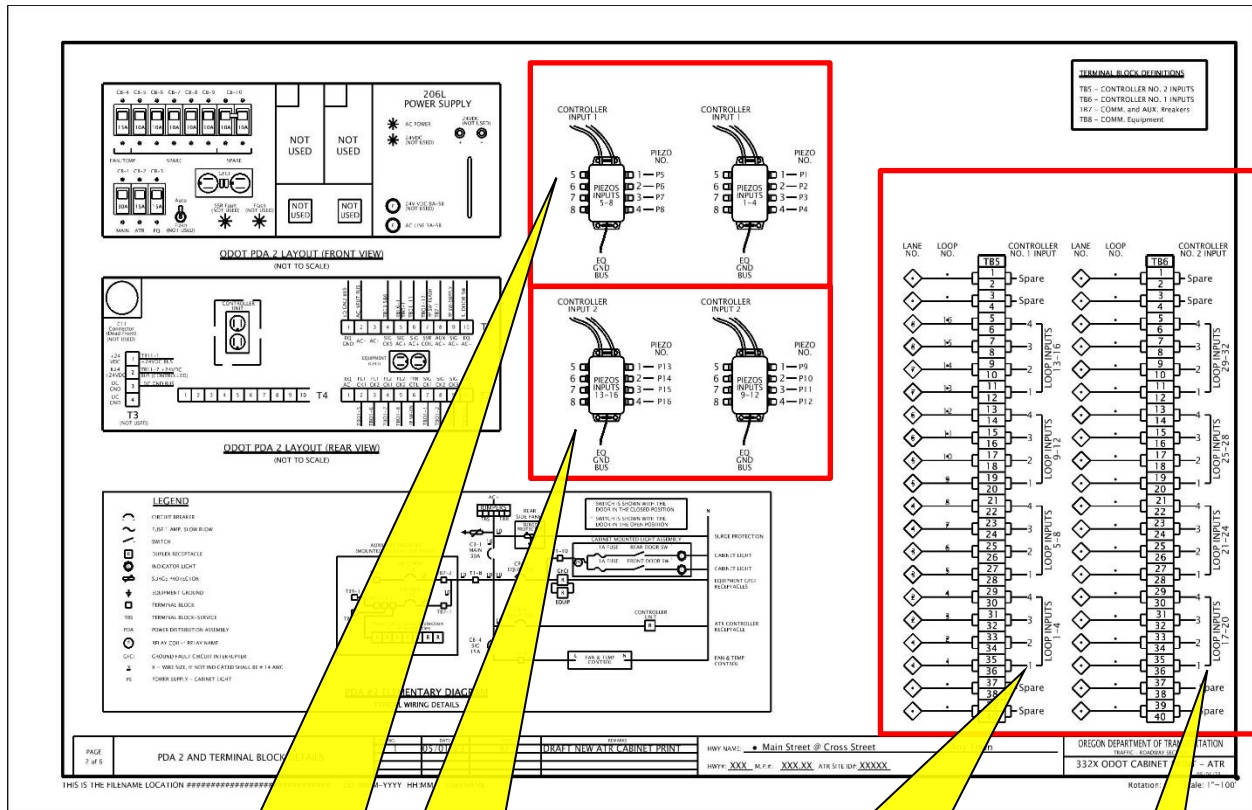

Piezo connector boxes for the standard placement of piezo sensors 1 thru 8.

Piezo connector boxes for the standard placement of piezo sensors 9 thru 16. REQUIRES A SECOND CONTROLLER.

Terminal block TB5 is the standard placement for loops 1 thru 16. Delete loop numbers/loop lane numbers not used.

Terminal block TB6 is the standard placement for loops 17 thru 32. REQUIRES A SECOND CONTROLLER.

25.20 Example Plan Sheets

Example project 1 includes both loops and piezos, which will typically have three plan sheets as shown in Figure 25-30 thru Figure 25-32.

Example project 2 includes non-invasive detection as shown in Figure 25-33 and Figure 25-34.

These figures are typical examples and highlight information that should be included on the project plan sheets.

Traffic Signal Design Manual – Automatic Traffic Recorder (ATR) Plan

Figure 25-30 | ATR Project Example 1, Sheet N01

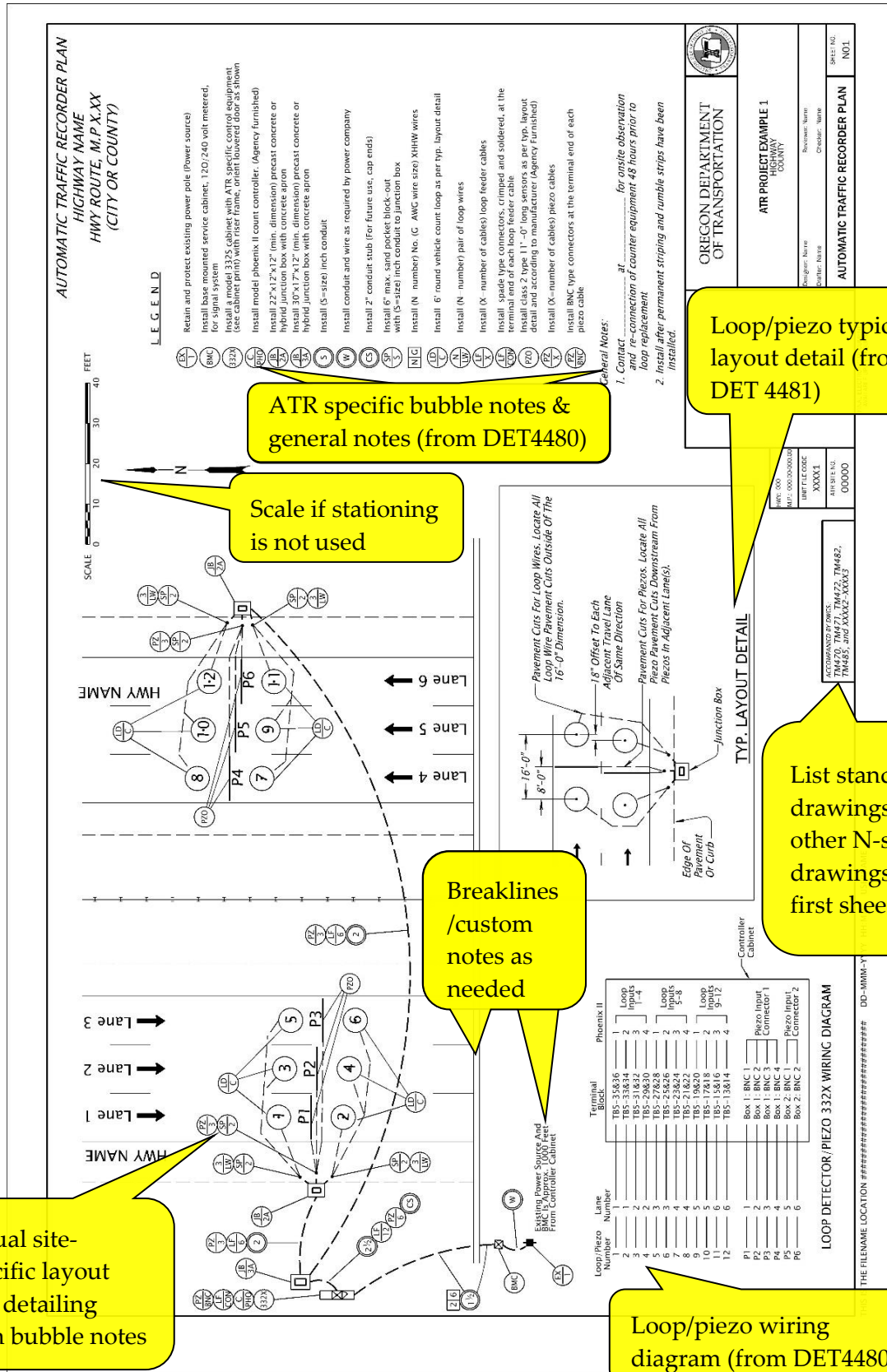

Actual site-specific layout and detailing with bubble notes

ATR specific bubble notes & general notes (from DET4480)

Scale if stationing is not used

Breaklines / custom notes as needed

Loop/piezo typical layout detail (from DET 4481)

List standard drawings & other N-series drawings on first sheet (N01)

Loop/piezo wiring diagram (from DET4480)

Figure 25-31 | ATR Project Example 1, Sheet N02

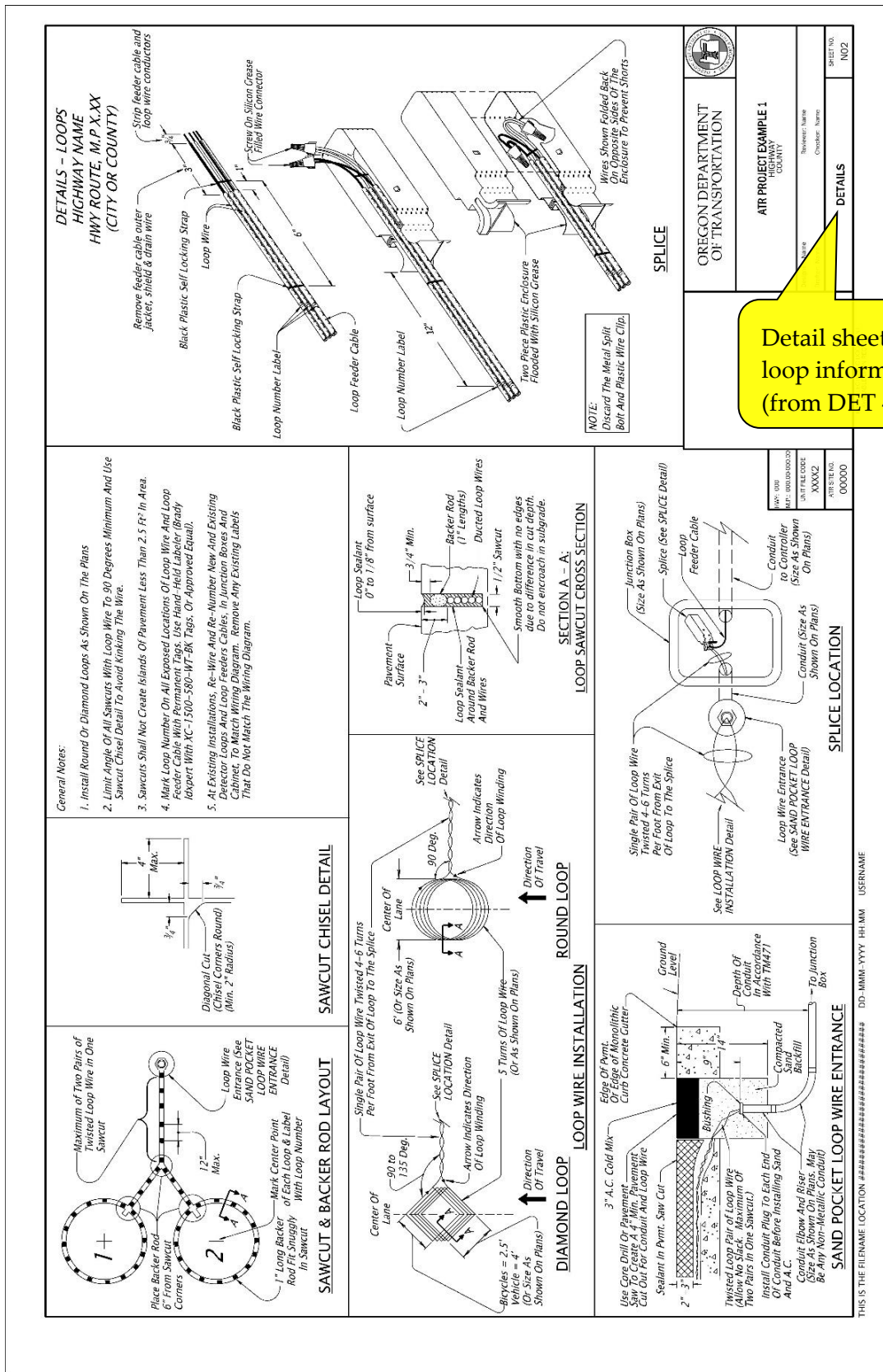

Figure 25-32 | ATR Project Example 1, Sheet N03

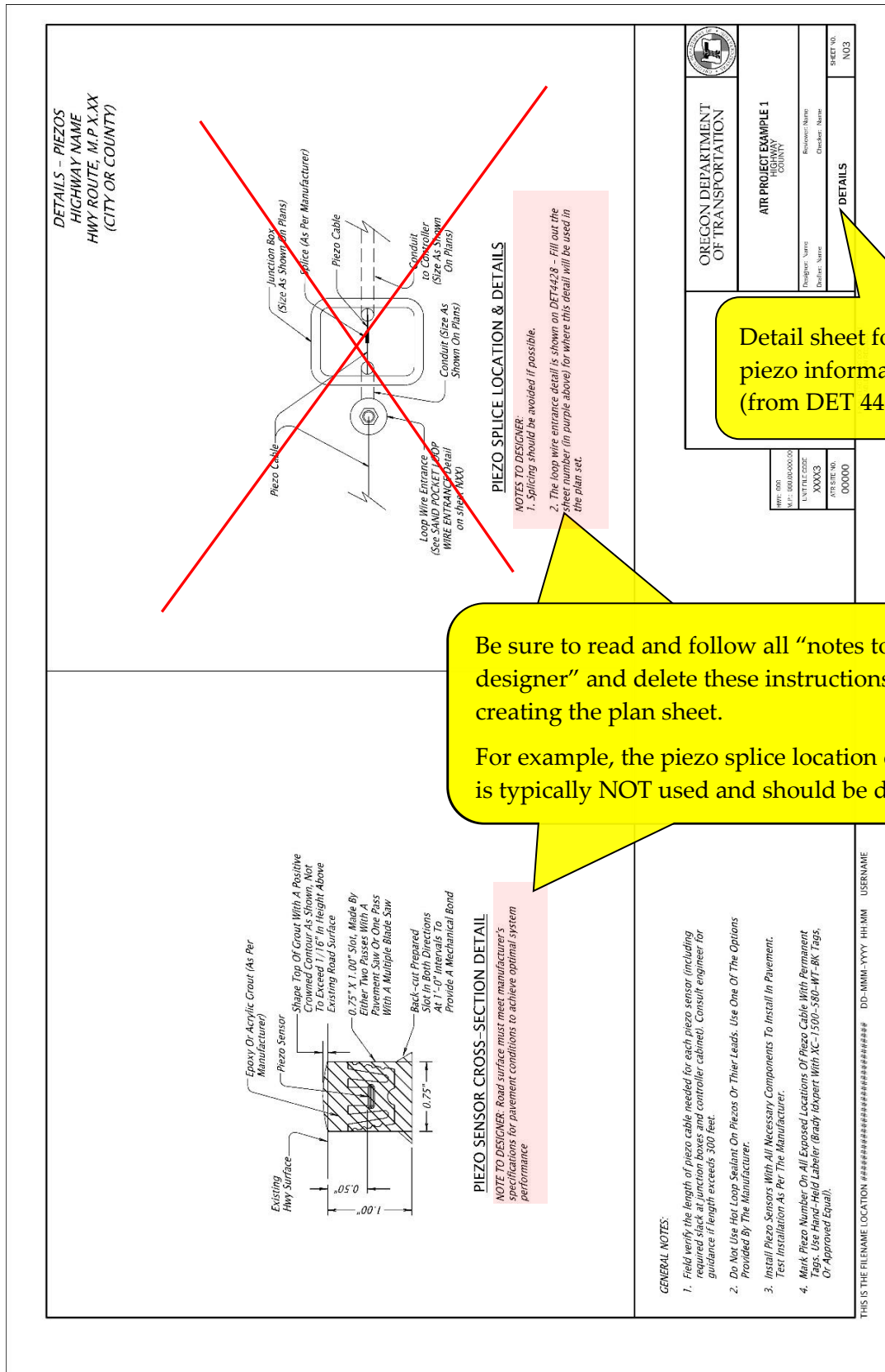
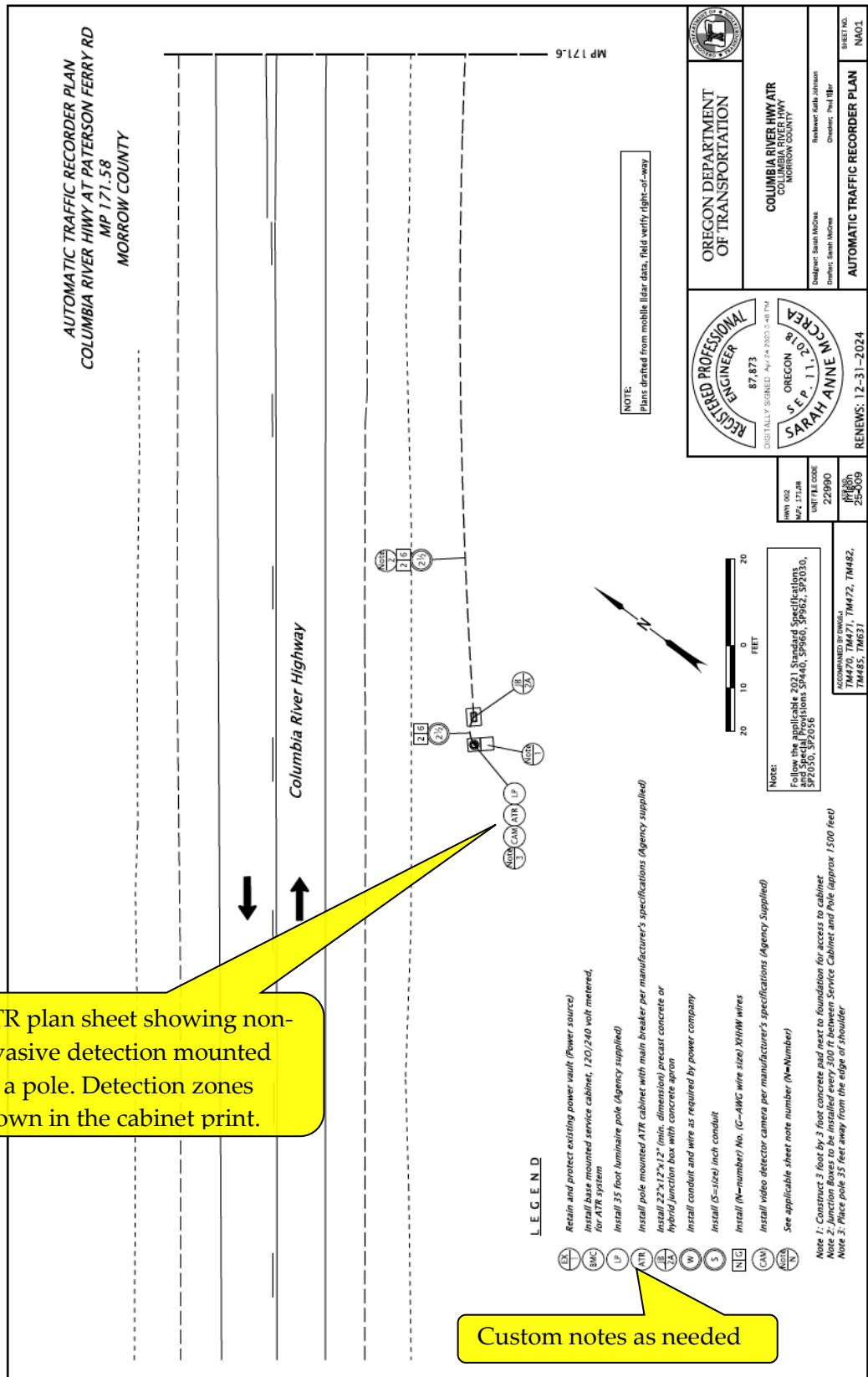

Figure 25-33 | ATR Project Example 2, Sheet NA01



ATR plan sheet showing non-invasive detection mounted on a pole. Detection zones shown in the cabinet print.

Custom notes as needed

Figure 25-34 | ATR Project Example 2, Sheet NA02

