

VERSION OCTOBER 2024

10/31/2024



BRIDGE DESIGN MANUAL

SECTION 2: PROCESSES

BRIDGE ENGINEERING SECTION

OREGON DEPARTMENT OF TRANSPORTATION

Table of Contents

Index of Tables and Figures..... vi

2.1 Introduction 1

2.2 Structural Design Software..... 2

2.2.1 Supported Software 2

2.2.2 Unsupported Software 3

2.2.3 MathCAD Template Library 4

2.3 Bridge Design Process (Design-Bid-Build), Overview..... 5

2.3.1 Field Scoping 5

2.3.2 Project Initiation and Project Kick-Off 6

2.3.3 Design Verification Package (End of Project Initiation Phase) 7

2.3.4 Bridge TS&L Package 7

2.3.5 Design Acceptance Package & DAP Phase Gate 8

2.3.6 Preliminary Plans Package Milestone 9

2.3.7 Advance Plans Package Milestone 10

2.3.8 Final Plans Package Milestone 11

2.3.8 PS&E Milestone 12

2.3.9 Bridge Design Project Close Out..... 12

2.4 Bridge Design Deliverables..... 13

2.5 Statewide Bridge Design Quality Plan..... 15

2.5.1 Bridge Design Quality Management..... 16

2.5.2 Quality and Technical Standards..... 17

2.5.3 Roles and Responsibilities 18

2.5.4 Quality Control..... 19

 2.5.4.1 Quality Control Milestones..... 20

 2.5.4.2 Quality Control Reviews and Checks 22

 2.5.4.3 Authority of the Reviewer 27

2.5.4.4 Software, Tool, and Data Validation 29

2.5.4.5 Quality Control Documentation 29

2.5.4.6 QC Communication 31

2.5.5 Quality Assurance..... 31

 2.5.5.1 Quality Assurance Review Process 31

 2.5.5.2 Quality Assurance Documentation 32

 2.5.5.3 QA Communications 32

2.5.6 Quality Verification 32

2.5.7 Additional Bridge Quality Review Processes 34

2.6 (Reserved) 36

2.7 QPL/Research..... 37

2.7.1 Qualified Products List (QPL)..... 37

2.7.2 Research..... 37

2.8 Scoping..... 38

2.8.1 Introduction 38

2.8.2 Local Agency 38

2.8.3 Bridge Scoping Tool (BST) 38

2.9 TS&L and DAP 41

2.9.1 Introduction 41

2.9.2 Bridge Design Criteria & Standards Assessment 41

2.9.3 Design Deviations and Exceptions 42

2.9.4 Bridge TS&L Package 42

2.9.5 Bridge TS&L Report..... 43

 2.9.5.1 Purpose of the Bridge TS&L Report 43

 2.9.5.2 When is a Bridge TS&L Report needed?..... 44

 2.9.5.3 Bridge TS&L Approval (In-House Design) 44

[2.9.5.4 Multiple Bridge Projects and the Bridge TS&L Report](#)..... 45

 2.9.5.5 Components of a Bridge TS&L Report..... 45

 2.9.5.6 Bridge Alternatives Study..... 46

2.9.6 Bridge Strategy Memo..... 46

2.9.6.1 Purpose of the Bridge Strategy Memo 46

2.9.6.2 When is a Bridge Strategy Memo needed?..... 46

2.9.6.3 Bridge Strategy Memo Approval..... 47

2.9.6.4 Multiple Bridge Projects and the Bridge Strategy Memo..... 47

2.9.6.5 Bridge Strategy Memo Contents 47

2.9.6.6 Bridge Options Study 48

2.9.7 Engineer’s Estimate at TS&L 48

2.9.8 Bridge TS&L Plan Sheets 48

2.10 Project Design/PS&E 49

2.10.1 Introduction 49

2.10.2 Sealing & Signing Requirements 49

2.10.3 Contract Plans..... 49

 2.10.3.1 At Preliminary Plans..... 49

 2.10.3.2 At Advance Plans..... 49

 2.10.3.3 At Final Plans..... 49

 2.10.3.4 At PS&E Package..... 50

2.10.4 Specifications & Special Provisions 50

 2.10.4.1 At Preliminary Plans..... 50

 2.10.4.2 At Advance Plans..... 50

 2.10.4.3 At Final Plans > Final Special Provisions..... 50

 2.10.4.4 At PS&E Package..... 50

2.10.5 Engineer’s Estimate 50

 2.10.5.1 At Preliminary Plans..... 50

 2.10.5.2 At Advance Plans..... 50

 2.10.5.3 At Final Plans..... 50

 2.10.5.4 At PS&E Package..... 50

2.10.6 Engineer’s Estimate of Probable Construction Schedule 51

 2.10.6.1 At Preliminary Plans..... 51

 2.10.6.2 At Advance Plans..... 51

 2.10.6.3 At Final Plans..... 51

2.10.6.4 At PS&E Package..... 51

2.10.7 Calculations & Calculation Books 51

 2.10.7.1 Types of Calculations..... 51

 2.10.7.2 Importance of Calculations..... 52

 2.10.7.3 Calculation Books..... 53

 2.10.7.4 Calculation Book Cover Sheet 54

 2.10.7.5 Table of Contents 54

 2.10.7.6 Calculation Sheets 54

 2.10.7.7 Other Calculation Material 54

 2.10.7.8 Calculation Book Numbers..... 54

2.10.8 Bridge Load Ratings 55

 2.10.8.1 Existing and Pre-Design Load Ratings..... 55

 2.10.8.2 Final Design and Stamped Load Ratings..... 56

2.10.9 Operations and Maintenance Manuals 56

2.11 PS&E to Award..... 58

2.11.1 Introduction 58

2.11.2 Changes to Bridge Deliverables after PS&E..... 58

2.11.3 Bridge Design Project Close-Out 58

2.11.4 Request for Information (RFI) 58

2.11.5 Addenda Letters..... 58

2.12 Construction Support..... 59

2.12.1 Introduction 59

2.12.2 Communications during Construction..... 59

2.12.3 Shop Drawing Review..... 59

2.12.4 Temporary Works Review 59

2.12.5 Construction Support Close-Out 59

 2.12.5.1 As-Constructed Drawings 59

 2.12.5.2 Final Calculation Book(s)..... 59

 2.12.5.3 Final Reports & Records..... 60

2.13 (Reserved) 61

2.14 Coordination with Other Project Team Members..... 62

2.14.1 General..... 62

2.14.2 Project Management 62

 2.14.2.1 Local & General Permits 62

2.14.3 Survey and Mapping, & Right-of-Way 63

 2.14.3.1 Survey and Mapping 63

 2.14.3.2 Right Of Way 63

2.14.4 Roadway 63

 2.14.4.1 Project Geometry 63

 2.14.4.2 Roadway Clearances..... 64

 2.14.4.3 Bikeways..... 69

2.14.5 Traffic and Mobility 70

 2.14.5.1 Traffic Handling and Data 70

 2.14.5.2 Moveable Bridge Traffic Control Equipment..... 70

2.14.6 Foundations and Geotechnical..... 71

2.14.7 Hydraulics and Scour 71

 2.14.7.1 Hydraulics, General 71

 2.14.7.2 Waterway Openings and Hydraulic Requirements for Stream Crossings 71

 2.14.7.3 Bridge Scour Design..... 72

 2.14.7.4 Hydraulics Documentation 74

2.14.8 Environmental 79

 2.14.8.1 Environmental Performance Standards & Permits 79

 2.14.8.2 Protection of Recreational/Cultural Resources 82

 2.14.8.3 Bird and Bat Habitat 83

2.14.9 Storm Water 84

2.14.10 Utilities – Roles and Responsibilities 84

2.14.11 Railroad 85

 2.14.11.1 Permits 85

 2.14.11.2 Railroad Considerations..... 86

 2.14.11.3 Railroad Clearances 86

2.14.12 Public Involvement..... 87
Appendix – Section 2.5 – Quality (In-House Design) 88

[Appendix A – ADA Design Bridge Curb Ramps](#)

[Appendix B – ADA Bridge Works Examples](#)

[Appendix C – Bridge TS&L Development Process Retooling](#)

[Appendix D – Roles & Responsibilities](#)

[Appendix E – Metric Conversion](#)

Index of Tables and Figures

Table 0-1 Supported Software 2
Table 2.2.2-2 Unsupported Software 3
Table 2.5-1 Statewide Bridge Design Quality Plan Revision History 15
Table 2.5.3-1: Bridge Design Quality Roles and Responsibilities 18
Figure 2.5.4-1 Bridge Quality Flowchart..... 19
Table 2.5.4.1-1 Quality Control Milestones -STIP..... 20
Table 2.5.4.1-2 Quality Control Milestones- Maintenance 22
Table 2.5.4.2.1-1 Criteria for Selection of Check Class for Bridge Elements 24
Table 2.5.6-1 Quality Verification Milestones 34
Figure 2.8.3-1 Bridge Scoping Tool Directions..... 38
Figure 0-1 Roadway Clearances for Structures..... 65
Figure 0-2 Clearance Envelopes 66
Table 2.14.4.2.4-1 Minimum Vertical Clearances..... 68
Table 2.14.4.2.5-1 Minimum Horizontal Clearances During Construction..... 69
Figure 2.14.7.4-1 – Sample Hydraulic Data Sheet..... 77
Figure 2.14.7.4-2 – Riprap Blanket and Toe Trench Detail..... 78
Figure 2.14.7.4-3 Hydraulic Data Example Table 78
Figure 2.14.11.3-1 – Railroad Construction Clearances 87

Note: Revisions for **October 2024** are marked with yellow highlight. Deleted text is not marked; past editions of the BDM are available for comparison.

2.1 Introduction

BDM Section 2 contains practices pertinent to design procedures and quality processes for completing highway bridge and structure design on STIP projects.

See *BDM Section 1* for standards, practices and design guidance pertinent to design of highway bridges and structures.

Procedure and Process Guides

[ODOT Project Delivery Guide](#)

[ODOT Highway Design Manual](#) – Design Standard Policies and Processes

2.2 Structural Design Software

2.2.1 Supported Software

The programs in *Table 2.2.1-1* are used and supported by the Bridge Section.

Table 0-1 Supported Software

Software Name	System	Comments	Contact Name
Midas Civil	7-64	bridge analysis and design	
DFSAP	7-64		
LPIle	7-64		
Group	7-64		
ODOT-Col	7-32	column analysis	
PAP	7-64		
FHWA INSTRUCT	Terminal Services		
Brass Girder LRFD	7-64		
Brass Girder STD	7-64		
Brass Library Utility	7-64		
Brass Pole			
PGSuper	7-64	WSDOT precast design program	
PSBeam	7-64		
Response 2000	7-64	Reinforced concrete sectional analysis using Modified Compression Field theory	
SIMON	7-64		
STLBridge LRFD	7-64	steel bridge design using LRFD	
QConBridge	7-64	WSDOT live load analysis program for continuous frames	
Convert 4.1	7-64		
Mathcad 15	7-64		
Mathcad Prime	7-64		

2.2.2 Unsupported Software

With the computer upgrade from Windows XP to Windows 7, most of the bridge legacy programs are out of date. The programs in *Table 2.2.2-2* are incompatible with the 64-bit systems or will no longer be supported.

Table 2.2.2-2 Unsupported Software

Software Name	Comments
Brig2d	replaced by RspBr2
CrkCol	
CrvBrgPc	Midas and GTStrudl have this function
DkElev	Microstation can perform this function
LdSort	
MStrudl	No longer in business – Midas and GTStrudl have this function
ODOT’s pole program	Uses MStrudl
Oregon’s PSBeam	Not Erikssons PsBeam, which ODOT now uses
Ultcol	Xtract can support this function
UltFtg	Program needed to do simple analysis for footing design (on piling and shallow foundation).
WinStrudl	No longer in business
XSection and WFrame	Caltrans programs
Drain2dx	Dynamic response analysis of inelastic plane structures
GTStrudl	Finite element analysis
LUSAS	
SAP 2000	Finite element analysis
SimQuake	DOS – simulation of time, position, and magnitude of earthquakes
Xtract	CalTrans – substitute for XSection and WFrame

2.2.3 MathCAD Template Library

The following MathCAD standard bridge rail calculations are posted on the [Bridge Standards website](#) under the “Software Tools for Design” section. The calculations document the bridge rail design and capacity:

- BR200_Calcs_2016 for *BR200*
- BR206_Calcs_2016 for *BR206*
- BR208_Calcs_2016 for *BR208*
- BR214_Calcs_2014 for *BR214* (will be updated in the near future)
- BR221_Calcs_2016 for *BR221*
- BR290_Calcs_2016 for *BR290*

The spreadsheet *Summary of ODOT Standard Rail Capacities* summarizes all the bridge rail capacities for deck overhang design.

ODOT IN-HOUSE DESIGN

Also available on the [Bridge Intranet](#) are the following calculation templates available for ODOT designers use to promote standardization and efficiency.

- Deck Overhang with Concrete Bridge Rail (MathCAD and MathCAD Prime)

2.3 Bridge Design Process (Design-Bid-Build), Overview

All processes described in this section use ProjectWise per:

- [Technical Services Directive TSB16-01\(D\) Use of ProjectWise for Project Design \(Engineering/Non Engineering\) Data Management](#)
- [Technical Services Bulletin TSB 17-01\(B\) ODOT ProjectWise Naming Convention](#)

2.3.1 Field Scoping

THE PROJECT (BY OTHERS)

Field scoping involves a reconnaissance level look at one or more alternatives for a project. It involves planning, conceptual design, and description rather than project-level design. This level of planning assists in securing funding and determining **level of effort** required by various work units. Field scoping identifies and documents site constraints, assumed or known design exceptions or deviations, and anticipated outsourced work.

BRIDGE DESIGN

The Bridge Program Unit initiates potential Bridge Program projects from queries run on the State's bridge data. The Bridge Program Unit completes a **Desk Scope**, and the Bridge Standards and Program Manager drafts an initial [ODOT Project Business Case](#). This information is then sent to the region for **Field Scoping**. By the end of Field Scoping, a Bridge Design Category(s), per *BDM 1.2.3* is determined. After the region scoping team completes the **Field Scoping**, the Region Project Sponsor completes the Final Business Case. Region representatives send the business case to the Bridge Program Unit for review and signature by the Bridge Standards and Program Manager. Should there be discrepancies the Bridge Standards and Program Manager would reconcile with the Project Sponsor before signing. The final ODOT Business Case is provided to a Transportation Project Manager (TPM) or Resident Engineer – Consultant Projects (RE-CP) by a Region Area Manager after STIP programming, and before the Project Initiation Phase. Also see [Highway Division Directive DES 01](#).

If there are significant unknowns about a project, an Advanced Investigation Phase may occur prior to STIP programming to better identify the proposed scope. Examples of advanced investigation include chloride testing of bridge decks, load rating, or strength testing of other bridge elements.

See *BDM 2.8.1* for additional information.

2.3.2 Project Initiation and Project Kick-Off

THE PROJECT (BY OTHERS)

Project Initiation is when the Final Business Case is revisited, scope is verified, and the Project Charter completed. Near the middle of the Project Initiation Phase the project is **kicked off** by the TPM or RE-CP. Final refinements to the scope, schedule and budget are documented for the completion of the Project Charter and the Project Initiation Phase.

BRIDGE DESIGN

The Regional Bridge Lead Engineer (RBLE) is involved at the beginning of the Project Initiation Phase when the TPM or RE-CP calls for resources to be assigned. The RBLE writes a Bridge Design Work Order (BDWO) to document bridge strategy (QC, scope, risks, assumptions, etc.) and propose bridge design or review resources to the State Bridge Design Engineer to approve (statewide basis). When Bridge Section elects to perform an internal review of the Bridge TS&L Report, a Bridge Standards Engineer will be assigned. For outsourced work, the RE-CP initiates the Statement of Work (SOW), with the assistance of subject matter experts, if not already done, or reviews any SOWs that have already been prepared. Also see [PDLT Operational Notice PD-02](#).

The bridge designer verifies the proposed bridge/structures scope of the project design and bridge design categories and begins development of design deviations and exceptions. Bridge designers use available scoping information, draft or final project charters, and the *BDM* to prepare the Bridge Design Criteria and Standards Assessment. Confirm completion of pre-design load rating, deck testing and certain preliminary analyses of existing bridges that will be not be replaced. Ensure results are appropriately reflected in the project charter and other work description documents.

ODOT IN-HOUSE DESIGN

The Bridge Design Team meets and reviews the BDWO, schedule and budget, project charters, CMR's, the project's scope and the ODOT Project Business Case. The Bridge portion of the *Region Quality Control Plan* is also reviewed at this time, and supplemented to cover any project specific needs.

The Bridge Designer and Reviewer complete the appropriate Bridge QC Checklist found in *BDM A2.5*. A list of responsibilities at this milestone for the Bridge Reviewer and Designer can be found in *Appendix D*.

2.3.3 Design Verification Package (End of Project Initiation Phase)

THE PROJECT (BY OTHERS)

The Design Verification Package consists of enough detail to **proof** the project concept that has been put forth and complete the Project Charter and CMR 0. Site constraints are identified, and alignments are close to final. Consider permanent and temporary traffic control, and note anticipated unique specification items. Include as many bid items as can be identified in cost estimates.

As needed, other work completed by others at this stage may include: survey control established, survey topography gathered, survey base map produced, existing right of way determined, environmental base map produced, Area of Potential Impact (API) identified, draft utility conflicts identified, horizontal and vertical alignments calculated, bridge bent locations set, and retaining wall locations set.

BRIDGE DESIGN

The appropriate bridge deliverables (*BDM 2.4*) for the assigned Bridge Design Category(s) are complete and ready to review by the Bridge Reviewer and the Bridge Standards Reviewer (if applicable). Review and update the Bridge Design Criteria and Standards Assessment and create a list of design deviations and exceptions for each alternative, if required. Structural analysis calculations may need to be started and sufficiently advanced to meet DAP milestone needs, and future Project Design Phase milestones. Include **significant cost** bid items on the Engineer's Estimate. A draft Bridge Plan Sheet may be prepared to include with the other project Design Verification Plans. Coordinate need with the Project Team.

ODOT IN-HOUSE DESIGN

The Bridge Designer and Reviewer complete the appropriate Bridge QC Checklist found in *BDM A2.5*. A list of responsibilities at this milestone for the Bridge Reviewer and Designer can be found in *Appendix D*.

2.3.4 Bridge TS&L Package

THE PROJECT (NEEDED INFORMATION FROM OTHERS)

The project is nearing the Design Acceptance Plans (DAP) milestone. Some items to be completed by others in support of the Bridge TS&L package include:

- Hydraulics: Preliminary Hydraulic Recommendations.
- Work Zone Decision Tree, traffic control method.
- Preliminary Geotechnical Report (see *GDM 21.4*).
- Roadway Alignments (horizontal and vertical).

BRIDGE DESIGN

The Bridge TS&L Package is complete, has been reviewed and approved by the Bridge Reviewer and the Bridge Section Internal Reviewer (if applicable), and is ready to include in the DAP. See *BDM 2.9.4* for what is included in the Bridge TS&L package.

Submit Bridge TS&L Package to the TPM or RE-CP and to the appropriate personnel to complete a Construction Review and Maintenance Review. Gather comments from a review meeting with Construction and Maintenance personnel to discuss comments

ODOT IN-HOUSE DESIGN

Submit Bridge TS&L Package to the State Bridge Design Engineer and to the Reviewer for review. The Bridge Designer, Reviewer and Drafter complete the appropriate Bridge QC Checklist found in *BDM A2.5*. A list of responsibilities at this milestone for the Bridge Reviewer and Designer can be found in *Appendix D*.

2.3.5 Design Acceptance Package & DAP Phase Gate

THE PROJECT (NEEDED INFORMATION FROM OTHERS)

The Design Acceptance Package (DAP) provides sufficient detail of project elements and staging to identify right of way and utility impacts, utility relocation needs, design deviations and exceptions, and to allow application for permits. Staging is complete except for minor details.

At this milestone, alignments are final and the project **footprint** is set. Changes after this stage should be seldom needed, and work after this stage is adding detail and refining the design. Each project team member is to review others' DAP deliverables to ensure the work is compatible between disciplines, and to address discrepancies.

Roadway often takes the lead on common products, such as distributing the DAP and compiling a complete cost estimate. A DAP Narrative will be prepared that incorporates all sections' commentaries. Reference may be made to other complete documents, such as the Bridge TS&L Report, providing only minimal data in the DAP Narrative for such sections. The DAP Checklist is completed by the TPM or RE-CP and the package submitted for the DAP Phase Gate Review.

Some items to be completed by others at or before the DAP milestone include:

- Roadway: Approved Design Exceptions, DAP Narrative, DAP Cost Estimate.
- Geotechnical: Preliminary Geotechnical Memo.
- Hydraulics: Draft Hydraulic Report and Preliminary Stormwater Recommendation.

BRIDGE DESIGN

Complete the Bridge portion of the DAP Narrative. Respond to any needs identified by the TPM or RE-CP. Participate in the Design Acceptance Workshop (DAW), if scheduled.

For Bridge Modernization and Retrofit Category projects, complete the following at the DAP Phase Gate to meet project PDII requirements:

- Design Controls, criteria and innovations.
- Structural issues to be considered.
- Alternatives studies.
- Special design elements.
- ADA considerations.
- Value Engineering.

Other items to be completed at or near the DAP milestone include:

- TS&L Report (including Alternative Study) or Bridge Strategy Memo.
- Approved Design Deviations and Exceptions.
- Bridge Section of the Project DAP Narrative.
- Information for permits.

Start structural analysis calculations and Project Development Phase plans. Calculations should be far enough advanced to identify significant interdisciplinary conflicts. For Phase II Seismic Retrofit projects, identify seismic deficiencies and proposed retrofit techniques. This likely requires seismic modelling.

Write unique specifications with enough detail to give reviewers an idea of the work and pay items involved. Include as many bid items in cost estimates as possible, although quantities may not be accurately calculated at this time.

ODOT IN-HOUSE DESIGN

A list of responsibilities at this milestone for the Bridge Reviewer and Designer can be found in *Appendix D*.

2.3.6 Preliminary Plans Package Milestone

THE PROJECT (NEEDED INFORMATION FROM OTHERS)

Preliminary Plans incorporate adjustments that are needed due to further refinement with right of way, utility, design deviations and exceptions completed, and permitting negotiations that have occurred. Each project team member is to review others' Preliminary Plans deliverables to ensure the work is compatible between disciplines, and there are no discrepancies. In some project schedules, the Preliminary Plans milestone is omitted.

Some items to be completed by others at the Preliminary Plans milestone include:

- Roadway: Preliminary Plans, Bid Summary/Cost Estimate.
- Geotechnical: Draft Geotechnical Report per *GDM*.
- Environmental: Obtaining permits is continuing during this phase.
- Utilities: Work with utility companies to establish utility relocations.

BRIDGE DESIGN

For Bridge Modernization Category work, the Project's Preliminary Plans Milestone (schedule) needs to be set such that the seismic design can be completed by this milestone. Include substantially complete structural calculations with Preliminary Plans milestone submission and prepare Preliminary Contract Plans. All plan sheets are started and show the basic geometry of all major elements. Identify boilerplate special provisions within the Engineers Estimate. When there is no applicable boilerplate special provision, provide a draft unique special provision. For unique specifications, begin the review process with appropriate [technical resources](#) and [specifications owners](#). Complete the Engineer's Estimate at Preliminary Plans including all bid items with rough calculated quantities. Provide bridge deliverables to the TPM or RE-CP for inclusion in the Preliminary Plans review package.

Provide bridge deliverables to the appropriate personnel to complete a Construction Review, Maintenance Review and State Bridge Engineer Review (see [BDM 2.5.6.4](#)). Gather comments from a review meeting with Construction and Maintenance personnel.

Some items to be completed at the Preliminary Plans milestone may include:

- Preliminary Plans.
- Engineer's Estimate that includes all bid items with rough calculated quantities.
- List of anticipated special provisions.
- All plan sheets are started and included in the review package.

ODOT IN-HOUSE DESIGN

When Preliminary Plans is skipped in the project schedule, for Bridge Retrofit and Bridge Modernization Category work, prepare Progress Plans (according to the BDWO) containing the standard Preliminary Plans deliverables. The Bridge Designer and Reviewer complete the appropriate Bridge QC Checklist found in [BDM A2.5](#). A list of responsibilities at this milestone for the Bridge Reviewer and Designer can be found in [Appendix D](#).

2.3.7 Advance Plans Package Milestone

THE PROJECT (NEEDED INFORMATION FROM OTHERS)

Advance Plans include all items necessary to bid and build the project. Each project team member is to review others' Advance Plans deliverables to ensure the work is compatible between disciplines; and review the entire plan set for clarity and consistency.

Some items to be completed by others at the Advance Plans milestone include:

- Roadway: Advance Plans, Construction Cost Estimate, Special Provisions.
- Construction: Construction Schedule.
- Geotechnical: Stamped Geotechnical Report per [GDM](#).
- Hydraulics: Stamped Final Hydraulics Report, Draft Stormwater Report.
- Environmental: Obtaining permits may be continuing during this phase.

BRIDGE DESIGN

Complete structural analysis calculations and prepare Advance contract plans. Substantially complete plan sheets (only lacking corrections based on QC Checking comments), including all geometry and details necessary for bidding and construction. Complete draft special provisions, including unique special provisions, and Engineer’s Estimate at Advance Plans, including a complete itemized list of bid items and accurately calculated quantities. Complete the Engineer’s Estimate of Probable Construction Schedule when required by project team. Provide bridge deliverables to the TPM or RE-CP for inclusion in the Advance Plans review package; and to the Bridge Checker for detailed structural QC check.

Some items to be completed at the Advance Plans milestone include:

- Advance Plans.
- Engineer’s Estimate.
- Special Provisions.
- Engineer’s Estimate of Probable Construction Schedule.
- Checker documents for Class II checks.

ODOT IN-HOUSE DESIGN

The Bridge Designer, Reviewer, and Checker complete the appropriate Bridge QC Checklist found in *BDM A2.5*. A list of responsibilities at this milestone for the Bridge Reviewer, Designer, and Checker can be found in *Appendix D*.

2.3.8 Final Plans Package Milestone

THE PROJECT NEEDED INFORMATION FROM OTHERS)

Completing Final Plans involves preparing for submittal of the design work and finalizing the PS&E package.

Some items complete at the Final Plans milestone include:

- Roadway: Final Plans, Construction Cost Estimate, Final Special Provisions.
- Construction: Final Construction Schedule.
- Environmental: Approved permits.

BRIDGE DESIGN

Address remaining comments from the detailed structural QC check and other reviews. Finalize structural analysis calculations and prepare Final contract plans. Complete the Bridge Checker calculations per *BDM 2.5.7.1* and submit to the Bridge Reviewer. Complete plan sheets (100 percent). Complete final special provisions, final Engineer’s Estimate of Probable Construction Schedule when required by project team, and Engineer’s Estimate at Final Plans. Provide bridge deliverables to the TPM or RE-CP for inclusion in the Final Plans package. Also see [PDLT Operational Notice PD-02](#) and [Final PS&E Submittal Checklist](#), and ensure the bridge related aspects of these documents are complete.

Some items to be completed at the Final Plans milestone include:

- Final Plans.
- Engineer’s Estimate.
- Final Special Provisions
- Bridge Design Calculation Book.

ODOT IN-HOUSE DESIGN

As noted on the BDWO, provide other deliverables that do not go to the TPM to the State Bridge Design Engineer. The Bridge Designer, Reviewer and Checker complete the appropriate Bridge QC Checklist found in *BDM A2.5*. A list of responsibilities at this milestone for the Bridge Reviewer, Designer and Checker can be found in *Appendix D*. Submit the draft calculation book to the Bridge Reviewer.

2.3.8 PS&E Milestone

THE PROJECT (BY OTHERS)

At PS&E, all the contract documents prepared by the Project Team are submitted to the Project Controls Office by the TPM or RE-CP to begin the process of advertising and bid letting.

BRIDGE DESIGN

Digitally sign plan sheets. Complete and digitally sign the Special Provision(s) POR sheet.

Finalize and digitally sign the calculation book(s) per *BDM 2.10.7* and email to Bridge Section: ODOTBridgeEngineeringSection@odot.oregon.gov. Assist the TPM or RE-CP to address any PS&E Package deficiencies before advertising; and to address any RFIs and Addendum Letters during advertising. When required, participate in the pre-bid meeting. Prepare the **design** bridge load rating per *BDM 2.10.8*.

ODOT IN-HOUSE DESIGN

The Bridge Designer, Reviewer and Checker complete the appropriate Bridge QC Checklist found in *BDM A2.5*. A list of responsibilities at this milestone for the Bridge Reviewer, Designer and Checker can be found in *Appendix D*.

2.3.9 Bridge Design Project Close Out

BRIDGE DESIGN

Within 60 days after award, complete Bridge Design Close-Out documents, per *BDM 2.11.3*.

2.4 Bridge Design Deliverables

1. Bridge Design Quality Plan (may be part of Region Design Quality Plan)
2. Beginning of Project Initiation
 - a. Bridge Design Criteria & Standards Assessment (DCSA)
 - b. Draft Bridge Design Deviations and Exceptions
 - c. Pre-Design Load Ratings (if applicable)
 - d. Site Visit Memo
3. Design Verification Package
 - a. Complete or substantially complete Design Alternatives Scoring Matrix
 - b. Alternatives Analysis
4. Bridge TS&L Package
 - a. Bridge TS&L Report (For Bridge Modernization Category) or Bridge Strategy Memo (For Bridge Retrofit Category)
 - b. DCSA
 - c. Bridge TS&L Plan Sheet(s)
 - d. Engineer's Estimate at TS&L
 - e. **Draft** Design Deviations and Exceptions
 - f. Alternatives or Options Study supporting data, if warranted
5. Design Acceptance Phase
 - a. DAP Narrative, Structures Section
 - b. DAP Plans
 - c. DAP Estimate
 - d. DCSA
 - e. Approved Design Deviations and Exceptions
6. Preliminary/Progress Plans Package
 - a. Preliminary Plans Plan Sheets
 - b. Engineer's Estimate at Preliminary Plans
 - c. Draft Unique Special Provisions
7. Advance Plans Package
 - a. Advance Plans Plan Sheets
 - b. Engineer's Estimate at Advance Plans
 - c. Engineer's Estimate of probable construction schedule (when required by project team)
 - d. Draft Special Provisions
8. Final Plans Package
 - a. Final Plans Plan Sheets
 - b. Engineer's Estimate at Final Plans
 - c. Updated estimate of probable construction schedule (when required by project team)
 - d. Final Special Provisions

- e. Draft Calculation Book(s)
- 9. PS&E
 - a. Signed Digital Plans
 - b. Signed POR Specification Sheet
 - c. Engineer's estimate
 - d. Final Calculation Book(s)
 - e. Final Design Load Rating (as required)
 - f. Microstation CAD Files
- 10. Bridge Design Project Close-Out
 - a. Native electronic computer files (Excel calculation files, MathCad calculation files, Structural analysis program files)
- 11. Construction Support documents
 - a. Responses to RFIs
 - b. Shop Drawing Reviews
 - c. Temporary Works Reviews
 - d. Falsework Reviews
 - e. Design Revisions
 - f. Site Visit Notes
- 12. At end of Construction (2nd Note)
 - a. Final Calculation Book(s)
 - b. Stamped Load Rating (as required)
 - c. As-Constructed Drawings

2.5 Statewide Bridge Design Quality Plan

Table 2.5-1 Statewide Bridge Design Quality Plan Revision History

Release Date	Changes Made By	Section(s) Updated	Summary of Change (what and why)
10/31/2024	Zach Beget	2.5	Changed ODOT internal QC Process to included back checking and QC Stamp.
4/30/2024			No changes.
10/31/2023	Zach Beget	2.5	Reformatted to match the Statewide Discipline QC template guide.
4/30/2023	Zach Beget	2.5	Added <i>Table 2.5-1</i> to document Bridge Design QC Plan Revision History
10/28/2022	Emily Clyburn, Zach Beget	All Sections 2.4 2.7 2.9.2 2.10.8	Moved from <i>BDM Section 3</i> to <i>BDM Section 2</i> . Cleaned up language in the deliverables section. Added Language around approval of items on the QPL. Cleaned up and added language for the DCSA. Added language about existing and Pre-Design Load ratings. Also cleaned up language for the Final design Load Rating.

Bridge QC Plan Revision Approval (Section 2 owner)

Signature on file

Zachary Beget – State Bridge Design Engineer

2.5.1 Bridge Design Quality Management

Quality in project delivery is the degree to which a product, service, or deliverable conforms with established project, design requirements, standards, satisfies its intended purpose, and meets the customer's requirements and expectations. Quality is the result of a cooperative partnership between the providers of project development services (engineering services and technical reports) and quality assurance. The deliverables that the Bridge Design Unit provides must undergo quality control (QC) to ensure that products and services meet customer requirements and expectations. Those responsible for quality assurance (QA) review the process to ensure the quality management efforts are achieving desired results. The bridge design quality management system efforts foster continuous improvement in the ongoing quest to meet customer expectations, provide high quality engineering and technical services, and make efficient use of resources.

The bridge designer is responsible for making sure that their deliverables are accurate and meet the requirements of the design. The bridge designer performs QC by establishing procedures for self-checking their own work for accuracy and correctness. The checker performs QC of the Designer's products. The reviewer and Region Bridge Lead Engineer (RBLE), practicing both QC and QA, are responsible for reviewing the overall work of the bridge designer and bridge checker to assure accuracy and correctness in meeting the design requirements and expectations of the bridge owner, and that they are conforming to this Quality Plan. For outsourced work, the consultants follow their approved QC Plan, but are expected to meet or exceed this quality plan. The Agency Bridge Reviewer (ABR), assigned by ODOT, performs Quality Verification (QV) of outsourced consultant work. The ABR reviews consultant work for conformance to standards, the work order contract, and the consultant quality plan. See *Bridge Design Manual (BDM) 2.5.3 and Appendix D* for additional information on designer, checker, and reviewer roles.

For the purposes of this document it will adhere to and be in compliance with FHWA '[Guidance on QC/QA in Bridge Design In Response to NTSB Recommendation \(H-08-17\)](#).' This guidance provides expectations for the establishment of Quality Control and Quality Assurance Programs in bridge design as well as definitions of the terms involved.

For internally developed projects, FHWA does not have a definition for Quality Verification (QV). Bridge section QA is the equivalent and fulfills the same purpose of QV in the Region Quality Plan for internal projects.

For a complete list of Glossary of terms see *BDM Appendix 1-1*.

Quality Control (QC): Procedures of checking the accuracy of the calculations and consistency of the drawings, detecting and correcting design omissions and errors before the design plans are finalized, and verifying the specifications for the load-carrying members are adequate for the service and operation loads.

Quality Assurance (QA): Procedures of reviewing the work to ensure the quality control are in place and effective in preventing mistakes, and consistency in the development of bridge design plans and specifications.

Quality Verification (QV): Procedures of reviewing consultant work and is completed by an Agency Bridge Reviewer (ABR) for outsourced work to verify that the consultant has completed and met the consultants' approved Quality Plan. The ABR completes the Bridge Review and Acceptance Checklist for every review performed on major milestones/deliverables.

2.5.2 Quality and Technical Standards

The [ODOT Project Delivery QA/QC Program website](#) provides an overview of the ODOT Project Delivery QA/QC Program, access to the quality standards of practice. The Project Delivery Quality Program Manual can be found there, as well as a listing of the quality plans and guidance documents, including the region Technical Center quality plans, the technical discipline quality plans, and the transportation project management statewide quality plan. There is also a listing of the associated quality forms and checklists.

Perform bridge design according to the Statewide Bridge Design Quality Plan in cooperation with the applicable Regional Technical Center Quality Plan and fulfilling the design standards outlined in *BDM 1.2.1*. The Region QC plans do not supplant the Bridge Design Quality Plan.

2.5.3 Roles and Responsibilities

The roles and responsibilities for implementing bridge quality management are described in this section. See *BDM Appendix D* for more detail on the roles and responsibilities.

Table 2.5.3-1: Bridge Design Quality Roles and Responsibilities

Roles	Responsibilities
Agency Bridge Reviewer (ABR)	An individual from ODOT's Bridge Engineering Section assigned to assist the Region's Transportation Project Manager (TPM) or Resident Engineer – Consultant Projects (RE-CP) when providing oversight for delivery of outsourced work on bridges and other structures. This includes assisting with the development of work order contracts, independent cost estimates, and quality verification reviews. See <i>BDM 2.5.6</i> for additional information.
Bridge Designer	An individual directly responsible for the development of design calculations, drawings, specifications and contract documents and review of shop drawings related to a specific bridge design with a level of technical skills and experience commensurate with the complexity of the subject structure or structures being designed.
Bridge Design Coordinator (BDC)	An individual that tracks changes in milestone delivery dates and coordinates with bridge project resources on upcoming milestones using the Bridge Deliverable Tracker.
Bridge Design Checker	An individual responsible for performing a full technical Quality Check of the design calculations, drawings, specifications, and contract documents.
Bridge Reviewer	An individual responsible for performing QC and QA beyond that of the structural check by the bridge checker. This may include all work performed before the bridge checker starts, integrated QC between disciplines, and spot checks of the structural design. May also act as a SME in lieu of a Standards Engineer.
Bridge Technical Resource/Subject Matter Expert (SME)	An individual assigned to the ownership of a set of standards or specifications. They perform QC through concurrence of the Specifications and review of plans to gain statewide technical consistency.
Bridge Engineer of Record (EOR)	An individual in responsible charge for overseeing aspects of the design of the structure including the design of all the structural and bridge systems and components. The Bridge Engineer of Record seals and signs the final contract plans and specifications for themselves or in supervision and control of non-licensed designers (OSBEELS Official Seals).
Region Bridge Lead Engineer (RBLE)	Performing as Bridge QA Reviewer when allowed in a Region Tech. Center Quality Plan.
State Bridge Design Engineer	Owner of the Bridge Discipline Quality Plan and ensures the established quality procedures and practices are followed and completed. Note: QA duties can be delegated to the Regional Bridge Lead Engineer (RBLE) or an assigned Bridge Reviewer.

2.5.4 Quality Control

Figure 2.5.4-1 Bridge Quality Flowchart

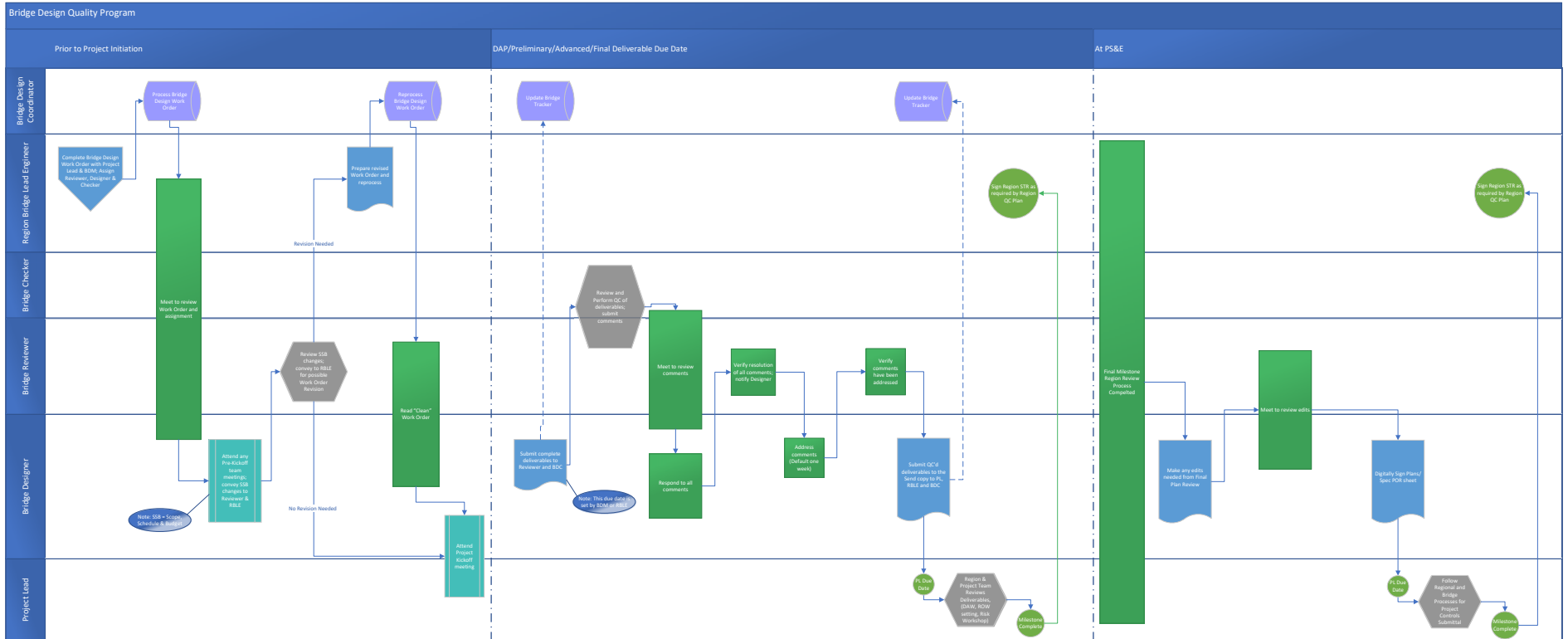

2.5.4.1 Quality Control Milestones

All bridge design work products that are intended to be used or reviewed by any discipline outside of bridge are required to undergo the QC process prior to distribution. *BDM 2.4* lists the most common deliverables that require undergoing the QC Process, ordered by milestone. This list is not exhaustive. For items not on the list reach out to your RBLE or manager to discuss.

Outsourced designs should have similar QC/QA touchpoints as listed in *Table 2.5.4.1-1*. See the consultant Quality Plan for specifics.

Consultant produced QC checklists need to meet or exceed the ODOT internal QC checklists. ODOT checklists are available to use by consultants.

Table 2.5.4.1-1 Quality Control Milestones -STIP

Milestone	Quality Documentation Required	Quality Review/Check Required
Project Scoping	<ul style="list-style-type: none"> Scoping Narratives Scoping estimate Bridge Scoping Spreadsheet 	Designer completes; Checker initials; Reviewer initials
Project Initiation	<ul style="list-style-type: none"> QC Bridge Designer Checklist, <i>ODOT form 734-5353</i> QC Bridge Reviewer Checklist, <i>ODOT form 734-5352</i> 	Signed checklist
Project Development Phase start-up	N/A	N/A
Design Verification Package (Completion of Project Initiation; Proof of Concept)	<ul style="list-style-type: none"> QC Bridge Designer Checklist, <i>ODOT form 734-5353</i> QC Bridge Reviewer Checklist, <i>ODOT form 734-5352</i> 	Signed checklist
Bridge TS&L Package	N/A	N/A
DAP/DAW	<ul style="list-style-type: none"> QC Bridge Designer Checklist, <i>ODOT form 734-5353</i> QC Bridge Reviewer Checklist, <i>ODOT form 734-5352</i> QC CAD Tech Checklist <i>ODOT form 734-5376</i> 	<ul style="list-style-type: none"> Signed checklist Signed checklist Follow <i>ODOT Bridge CAD Manual, see Section 203</i>
Preliminary Plans Package	<ul style="list-style-type: none"> QC Bridge Designer Checklist, <i>ODOT form 734-5353</i> QC Bridge Reviewer Checklist, <i>ODOT form 734-5352</i> 	Signed checklist

<p>Advance Plans Package</p>	<ul style="list-style-type: none"> • Bridge Designer QC Checklist, <i>ODOT form 734-5353</i> • Bridge Checker QC Checklist, <i>ODOT form 734-5354</i> • Bridge Reviewer QC Checklist, <i>ODOT form 734-5352</i> • Bridge CAD Review Checklist <i>ODOT form 734-5376</i> 	<p>Signed checklist</p> <p>Follow <i>ODOT Bridge CAD Manual, see Section 203</i></p>
<p>Final Plans Package</p>	<ul style="list-style-type: none"> • QC Bridge Designer QC Checklist, <i>ODOT form 734-5353</i> • QC Bridge Reviewer Checklist, <i>ODOT form 734-5352</i> 	<p>Signed checklist</p>
<p>PS&E Package/Project Close-out</p>	<ul style="list-style-type: none"> • QC Bridge Designer Checklist, <i>ODOT form 734-5353</i> • QC Bridge Reviewer Checklist, <i>ODOT form 734-5352</i> • STR (Region Tech Center QC), <i>ODOT form 734-5365</i> 	<p>Signed checklist</p>
<p>Construction Support</p>	<ul style="list-style-type: none"> • Revised calculations • Shop Drawings and RFIs • As-Constructed Plans 	<ul style="list-style-type: none"> • Reviewer/EOR to review and/or check calculations • Designer to review and mark; EOR to verify changes on shop drawings and RFIs • As constructed plans, follow <i>ODOT Bridge Cad Manual & Construction Manual</i>

Table 2.5.4.1-2 Quality Control Milestones- Maintenance

Milestone	Quality Documentation Required	Quality Review/Check Required
Final Plans Package	<ul style="list-style-type: none"> • Bridge Designer QC Checklist (Bridge Maintenance), ODOT form 734-5368 • Bridge Maintenance Reviewer QC Checklist ODOT form 734-5370 • Bridge Maintenance Checker QC Checklist, ODOT form 734-5369 	Signed checklist

2.5.4.2 Quality Control Reviews and Checks

Bridge designers, checkers, and reviewers are the key personnel to provide well designed and constructible plans to build quality bridges. They must be technically competent in the design element(s).

The EOR is responsible for the design. A checker’s duty is to ensure the technical content is correct and to identify potential efficiencies, overly conservative designs, and constructability improvements.

2.5.4.2.1 Class of Checks

Design checks fall into one of the following classes. Either the bridge designer or checker’s experience and competency will be commensurate with the complexity of the bridge work being designed, as ensured by *Table 2.5.4.2.1-1*. Supply quality documentation for all calculation books according to *BDM 2.10.7.3*.

When the bridge or bridge element being checked is not described in *Table 2.5.4.2.1-1*, Independent (Class 1) calculations are required.

A check starting as Line-by-Line can be escalated to independent calculations with approval of the Bridge Reviewer. A check starting as independent calculations may not be reduced to Line-by-Line.

The items in *Table 2.5.4.2.1-1* were agreed to between the Bridge Standards, Program Manager and FHWA Bridge Representative circa 2013. No changes or deviations from this table should be made without discussing with both parties. To request a deviation from the practice noted in *Table 2.5.4.2.1-1*, see *BDM 1.2.2*.

CLASS 1:

- Prepare independent structural calculations and quantity calculations.
- Check plans, specifications, and estimate.

In an independent check, the checker prepares their own calculations based off plan sheets and sketches prior to seeing designer calculations. After the checker has prepared their calculations, the checker and designer compare results. Generally, this type of check takes longer than a line-by-line. An independent check can be used as a tool to build technical competency.

CLASS 2:

- Perform Line-by-Line check of bridge designer's structural calculations.
- Prepare independent check of quantity calculations.
- Check plans, specifications, and estimate.

A Line-by-Line check means the checker will work from a substantially complete copy of the designer's calculations. The checker reviews the Table of Contents to ensure it is in order, complete, and that all expected entries are included. The checker then reviews the givens and the assumptions, and the Design Criteria & Standards Assessment. The checker then goes through the calculations line-by-line. Besides checking line-by-line, the checker must also see if the designer included all required calculations.

CLASS 3:

- No structural calculations.
- Prepare independent check of quantity calculations.
- Check plans, specifications, and estimate.

Use Class 3 check procedures for Bridge Preservation Category work except for calculations in support of phase 1 seismic retrofits.

Use *Table 2.5.4.2.1-1* to determine if a line-by-line check is acceptable, or if an independent check is required based on the experience of the checker. This ensures the checker is technically competent to perform a line-by-line check in the discipline they are reviewing and possesses equal or greater technical competency than the designer. Classes of checks can only be different for a bridge if more than one checker is assigned for superstructure and substructure elements. If one element experience on the superstructure or substructure (or one checker assigned to entire bridge) directs to a Class 1 check, then the entire superstructure and substructure elements will require a Class 1 check as well.

These are minimum guidelines and no matter the element or experience, a Class 1 check can be used at the agency or consultant's discretion. High complexity of a bridge might still warrant a Class 1 check.

Table 2.5.4.2.1-1 Criteria for Selection of Check Class for Bridge Elements

Design Element	Class 2	Class 1
Geometry / Layout	Regular; Tangent; Simple-Span	Irregular; Curved ¹ ; Skewed ² ; Multi-Span
Standard Drawings / Details	Acceptable	If judged necessary
Major / Unusual / Complex	Not acceptable	Required
Seismic Design / Retrofit ³	Acceptable for Design Categories A & B	Required for Design Categories C & D
Prestressed Slabs ⁴	Must have successfully completed 2 prior designs	< 2 prior designs
Prestressed Boxes ^{Error! Bookmark not defined.}	Must have successfully completed 2 prior designs	< 2 prior designs
Prestressed Tubs ^{Error! Bookmark not defined.}	Must have successfully completed 2 prior designs	< 2 prior designs
Prestressed Girders ^{Error! Bookmark not defined.}	Must have successfully completed 2 prior designs	< 2 prior designs
Post-Tension anything	Not acceptable	Required
Steel Plate Girder	Must have successfully completed 2 prior designs	< 2 prior designs
Steel Trapezoidal Girder	Must have successfully completed 2 prior designs	< 2 prior designs
Abutments	Acceptable for Regular; Non-Integral	Required for Integral & Semi-Integral
Columns	Not acceptable	Required
Bridge Strengthening and element repair and replacement	Must have successfully completed 2 similar designs	< 2 prior designs
Rail Retrofits	Must have successfully completed 2 similar designs	< 2 prior designs
Temporary Works	Must have successfully completed 2 similar designs	< 2 prior designs

1 Curvatures with radius < 1000 feet.

2 Skew > 20 degrees.

3 Includes capacity protection design.

4 ODOT standard shapes only; other do independent calculations.

2.5.4.2.2 QC Workflow

This is the expected internal to ODOT workflow to be followed. All documents need to be stored and worked on in ODOT's ProjectWise.

BRIDGE DESIGN REVIEWER/DESIGNER/CHECKER:

Step 1

The Designer of deliverable(s) will:

- Create a PDF with a sheet at the start of the file with the QC Stamp added and filled out (date and signature; first line) appropriately for all deliverables of the original documents for the given milestone (except for Special Provisions) using the file naming convention (BR_K#####_QC_##) and a similar Document Description (Example: QC Document DAP TS&L Memo - to Reviewer). List all Bridge/Structures Numbers for the project in the file Attributes. There are two QC Stamps depending on who is responsible for performing the QC, Reviewer or Checker. Use the appropriate one.
- Place a Special Provisions Comment Log into the ProjectWise folder and add titles for all included Special Provision sections. Only one Special Provisions Comment Log is created, use new sheets to show different milestones.
- Create a 'Set', in the Structures folder, for all the QC files that will be used throughout the entire Project Development process; names the set file (QC K##### - BR#####) and creates a Document Description that clearly describes Set file contents (Example: Bridge QC Files - K#####).
- If not already added, place a Quality Checklist Set file into the 7_Quality Folder in PW and link the Checklists used/needed. See BDM Section 2.5.5.2 for naming convention.
- Complete QC Checklists for the appropriate milestone section(s).
- Emails links to the set files to the Reviewer/Checker, RBLE and BDC to initiate the QC Review or check.

Step 2

The Reviewer (and Checker) of deliverable(s) will:

- Perform the QC review and places comments inside the QC documents. Date and sign (second line) the QC Reviewer/Checker Stamp. In Bluebeam "flatten" all comments (Document, Flatten).
- Reply with links to the designer, via email, stating the QC Review or Check is complete.
- If needed, the checker will place calculations into ProjectWise and use the checker naming convention for these (Example: BR_K#####_CQC_Calc_##).
- Complete QC Checklists for the appropriate milestone section(s).

Step 3

The Designer of deliverable(s) will:

- Address all QC review comments graphically (not only in a markup list alone) inside

the QC document. Date and sign (third line) the QC Reviewer and Checker Stamp. In Bluebeam “flatten” all comments (Document, Flatten).

- Reply to the reviewer with links, via email, that all QC review comments have been addressed.
- Schedule and attends a ‘Sit Down’ with reviewer to review comment responses.
- Complete QC Checklists for the appropriate milestone section(s).

Step 4

The Reviewer and Checker of deliverable(s) will:

- Verify Designer responses to comments. Date and sign (fourth line) the QC Reviewer/Checker Stamp.

Step 5

The Designer of deliverable(s) will:

- Address comments with the CAD Tech to make needed changes to the plans.
- Make changes to the estimate as needed.
- Date and sign (fifth line) the QC Reviewer/Checker Stamp.
- Emails links to the set files to the Reviewer/Checker, RBLE, BDC to backcheck the QC review or check.

Step 6

The Reviewer and Checker of deliverable(s) will:

- Perform a back check to verify that all comments are incorporated into the deliverable.
- Email the Designer to make further change or to proceed with submitting to the Region.
- Date and sign (sixth and last line) the QC Reviewer/Checker Stamp.

After the above QC Process is complete:

1. The designer submits milestone deliverables to Region in accordance to the Region’s submittal process. Inquire with the respective Regions RBLE for Region-specific processes.
2. Sends an email (or cc: on submittal email to Region) to RBLE and BDC for Deliverables Tracker update.
3. Reviewer verifies all QC checklists are completed through the appropriate project milestone.

2.5.4.3 Authority of the Reviewer

2.5.4.3.1 Troubleshooting Bridge Design Quality

The following is what to do when Bridge Design Quality is not being met:

- Early intervention by the reviewer will get the best results and get a project back on track.
- Discussion/Review by State Bridge Design Engineer, Region Tech Center Manager, Bridge Reviewer, and Bridge Program and Standards Engineer.
- Review of approved bridge design resources by State Bridge Design Engineer to see if a change in resourcing is needed or change resource's other assignments before making resource reassignment.
- Provide training, internal or external, as schedule allows.
- Provide coaching or mentoring of resource as schedule allows.

2.5.4.3.2 Recovery Plans

The purpose of a recovery plan is to document specific tasks that need to be done, with dates required to get back on schedule or back in budget. Develop a recovery plan when changes in scope or issues related to standards arise in the Project Design Phase.

IN-HOUSE DESIGN

After troubleshooting any bridge design Quality issues, the State Bridge Design Engineer or RBLE will prepare a brief narrative plan documenting these tasks and measures; keeping a copy and providing a copy to the bridge designer and the bridge reviewer.

OUTSOURCED DESIGN

Consultants to follow their approved QC Plan for recovery and the authority of the reviewer. If consultants do not have a recovery plan as part of their QC plan, then they will defer to ODOT's.

BRIDGE REVIEWER REVIEW (QC/QA)

The bridge reviewer should be familiar with ODOT Bridge Engineering Section's Standards of Performance and ODOT's project delivery and construction practices, procedures, and policies. The bridge reviewer is a senior level engineer and has the authority to oversee and guide the direction of the bridge design portion of the project.

- May request Subject Matter Expert review (not a check), including welding, protective systems, and bridge inspection.
- May request Structural Materials Engineer review.
- May request Region Bridge Inspector (RBI) review for bridge inspection features.
- Ensures that Construction Review (Region QC Plan) has been performed.
- Ensures that Maintenance Review (Region QC Plan) has been performed.
- Ensures that checker review has been performed.

Most often, the reviewer and EOR will address recommendations and changes in a collaborative manner and create a work product that satisfies both parties. However, situations will arise where this is not tenable. For those cases, guidance is needed as follows:

- Recommended changes to the work will generally fall into three categories:
 - 1) those that represent different ways to analyze or view the work that are suggested or advisory.
 - 2) those that represent differences of opinion that do not violate the standard of care or impact the safety of the public, and
 - 3) those that violate the standard of care or impact the safety of the public.
- Compromise and open-minded communication are crucial. Further, it is the EOR's first duty to try and solve the matter with the reviewer. The reviewer should make every possible effort to explain their position to the EOR and listen to feedback. Failing resolution between the parties, the resolution will vary depending on the nature of the dispute.
- For changes requested by the reviewer that would fall into the first category and would be considered suggestions of feedback, the EOR should respond to the reviewer but does not need to document their choice to not incorporate the suggested changes.
- For the second category, differences not violating the standard of care or impacting the safety of the public, the EOR should respond to each item individually and document why they are not implementing the recommendation.
- For differences that either party (EOR or reviewer) considers violating the standard of care or impact safety of the public and that cannot be resolved, the EOR shall next work with the unit manager and then the Technical Center manager (or section manager in the case of a centralized discipline) prior to seeking other ways of resolving the problem. Other ways of resolving the issue include an approval to a deviation or design exception by the delegated authority for the discipline.
- Reviewers cannot require licensed engineers to change work in a way that would endanger the public or violate the standard of care.
- Licensed engineers are expected to address issues of standard of care or public safety. Only if proposed changes jeopardize the safety of the public or violate the standard of care, would the licensed professional have an argument for not being responsible for sealing the work. Responsible for performing role as noted in *Appendix D* and per bridge reviewer QC Checklist.

2.5.4.4 Software, Tool, and Data Validation

See the internal bridge website, and *BDM 2.2*, for list of ODOT supported and unsupported software. [Bridge Software \(sharepoint.com\)](#)

COMMERCIALLY AVAILABLE SOFTWARE WITH WHICH ODOT IS FAMILIAR:

- Software that is shown on the Supported Software section of the website has been in use and approved through many design and checking iterations.
- A designer/mentor/reviewer experienced in the use of the software will provide training for other designers new to the use of that software.
- Software users can complete hand calculation spot checks to ensure that calculations performed within the software are providing accurate results.
- Software users will document inputs and assumptions by means of a written design criteria or a basis of design narrative.
- EORs will perform software input & output reviews to confirm that software has been used correctly.
- Checkers will perform checks (Class of Check is dependent on BDWO and the experience of the Checker) and independent results when compared to designer values.

COMMERCIALLY AVAILABLE SOFTWARE NEW TO ODOT:

- Standards Engineers or delegate will become familiar with the software and its methodology to determine it is accurate and appropriate for the intended use.
- Standards Engineers or delegate will validate software results before implementing its use on a project.
- Software requirements for consultant designs are incorporated into the SOW.

SPREADSHEETS/MATHCAD:

Designers and engineers will check their spreadsheet formulas and logic. The EOR will complete review of spreadsheet formulas for non-licensed designers and validate spreadsheet results to confirm that equations and paths are correct.

2.5.4.5 Quality Control Documentation

As project QC work is done, quality records are created that provide reviewable evidence documenting that quality work was done. These quality records also provide the basis for quality reviews and/or audits (performed by professional auditors).

The following are the checklists that are utilized to track and direct the QC process for the individual resources.

STIP

The following is a list of the primary Bridge documents to retain in Agency's ProjectWise system. In the rare case the project is not in ProjectWise, retain documents in a folder on the Bridge Section server in which the data can be accessed for Quality Assessment/Auditing purposes. Electronic

pdf files are required in lieu of paper hardcopies. For A&E Consultant designs, the Design Contractor will submit these documents to the ODOT Agency Project Manager (APM) identified in the contract. The ODOT APM will transmit the documents to the assigned bridge reviewer (or the RBLE if there is no assigned bridge reviewer) and the State Bridge Design Engineer copying the BDC. The supporting Hydraulics and Geotechnical Reports are retained in the ODOT Geo-Environmental Section.

1. For in house design: ODOT Bridge Design Work Order (retained on Bridge Server);
2. For external design: A&E Personal Services Contract
3. Project Initiation deliverables
4. Bridge TS&L Submittal (reviewed and final copy(s))
5. Preliminary/Progress Plans Package (reviewed and final copy(s))
6. Advance Plans Package (reviewed and final copy(s))
7. Final Plans Package (reviewed and final copy(s))
8. Calculation Book(s) per *BDM 2.10.7.3*
9. Checker Review Comments/Forms
 - Review Comments, Responses, and QC Verification
 - Checker: <https://www.oregon.gov/odot/Forms/2ODOT/7345354.pdf>
10. Reviewer Review Comments/Forms
 - Review Comments, Responses, and QC Verification
 - Reviewer: <https://www.oregon.gov/odot/Forms/2ODOT/7345352.pdf>
 - ABR: <https://www.oregon.gov/odot/Forms/2ODOT/7345371.pdf>
11. Designer: <https://www.oregon.gov/odot/Forms/2ODOT/7345353.pdf>

DISTRICT

The following is a list of the bridge documents to retain in a folder on the Bridge Section server or ProjectWise folder (when available).

- ODOT Bridge Design Work Order, if available, original and any revisions.
- Project Initiation deliverables, when required.
- Options Memo (reviewed and final copy(s)) when required.
- Checking Package (reviewed and final copy(s)).
- Final Plans Package (reviewed and final copy(s)).
- Calculation Book(s).
- Checker & Reviewer Review Comment Forms.
 - Designer: <https://www.oregon.gov/odot/Forms/2ODOT/7345368.pdf>
 - Checker: <https://www.oregon.gov/odot/Forms/2ODOT/7345369.pdf>
 - Reviewer: <https://www.oregon.gov/odot/Forms/2ODOT/7345370.pdf>
- Review Comments, Responses, and QC Verification.

These forms and documents along with the ProjectWise process stated in *Section 2.5.4.2.2* will provide the digital paper trail that is needed for others to perform a quality audit. For projects that have a ProjectWise folder all the QC records in ProjectWise are stored in their regular discipline or milestone directory, with either “QC”, “QA”, or “QV” in the document title or

description, to facilitate searches for quality documentation. A set of quality files from each discipline or milestone folder in ProjectWise will be created in the ProjectWise “7_quality” folder. The set naming convention for <discipline> will be as follows:

BR_K#####_##.

For MBM projects that do not have a ProjectWise folder the same process in *Section 2.5.4.2.2* will be followed, but the files will be stored on the Bridge Share Drive in the location of the Leadworker folders.

2.5.4.6 QC Communication

Email will be used to document all QC communication. The process for who to email is outlined in *Section 2.5.4.2.2*.

Designer:

- To Reviewer: Send email to the RBLE, reviewer and Bridge Design Coordinator on all internal QC deliverables. Place links to all QC files within the body text of the email.
- To Checker: Send email to the RBLE, reviewer, checker, and Bridge Design Coordinator on all internal QC deliverables. Place links to all QC files within the body text of the email.
- To Region: Send email to the RBLE, reviewer and Bridge Design Coordinator on all final Milestone deliverables. Place links to all QC files within the body text of the email.

Checker:

- To Designer: Send email to Designer and Reviewer on pertinent QC correspondence.

Reviewer:

- QC Closeout: Send email to RBLE, Designer and Bridge Design Coordinator stating that all QC is completed for the subject project.

2.5.5 Quality Assurance

Quality assurance (QA) is a system undertaken to maximize the effectiveness of the quality program. The QA process will assist in measuring the effectiveness of the quality efforts to provide input into continuous improvement of the work and assist in identifying technical development needs.

2.5.5.1 Quality Assurance Review Process

The bridge reviewer provides Quality Assurance at a project-by-project level. The reviewer is verifying that all QC deliverables (even their own) are completed and filled out according to the process defined in the document.

Together the State Bridge Design Engineer and the RBLE follow and maintain technical competency gaps of employees. When it comes to resourcing the designer and checker on

projects the technical competencies, the individual employees' strengths, and their availability are evaluated to find the right fit for the given project.

The State Bridge Design Engineer(s) and the RBLE's meet quarterly to hold forums to discuss anything related to bridge design. A topic that is always open and discussed is on improvements to the current QC Plan. Lessons from projects are discussed and what went well and what didn't and then adjust as needed to improve the Bridge Quality Plan.

2.5.5.2 Quality Assurance Documentation

Quality records in ProjectWise are stored in their regular discipline or milestone directory, with either "QC", "QA", or "QV" in the document title or description, to facilitate searches for quality documentation. A set of quality files from each discipline or milestone folder in ProjectWise will be created in the ProjectWise "7_quality" folder. The set naming convention for Bridge will be as follows:

BR_K#####_QC/QA/QV

2.5.5.3 QA Communications

Reviewers follow the outline in [Section 2.5.4.2.2](#).

2.5.6 Quality Verification

AGENCY BRIDGE REVIEWER (REGION CONTRACT)

An Agency Bridge Reviewer (ABR) will provide QV for outsourced projects with work on bridges and other structures. The assigned ABR is the bridge representative for the Contract Administrator (CA). The ABR contributes to quality through consultant selection (when requested), assisting with development of the statement of work (SOW), assisting with development of the Breakdown of Costs (BOC), negotiating costs (when requested), and deliverable review.

Once Notice to Proceed (NTP) is released, the ABR will transition into QV and be the first line of answering questions from the consultant; being proactive early with the consultant and Bridge Standards during project initiation will help to set the project on the correct path.

ABR's document project comments according to Bridge's and the Region's established quality process. Recommendations for acceptance, partial acceptance, or rejection are documented using the A&E Review & Acceptance Checklist, ODOT form 734-5371.

The ODOT ABR shall review the approved consultant Quality Plan and refer to the Quality Plan to ensure the consultant's quality process and documentation are being followed and met throughout the entire project.

Deliverables are accepted or rejected by the Contract Administrator (CA). Due to the numerous disciplines within ODOT, CA's regularly delegate deliverable review to specific disciplines. In the case of ODOT Bridge Section, these duties are performed by the ABR.

The A&E Review & Acceptance Checklist is broken into two broad sections for 'Substantial Conformity' and 'Technical Review'. Substantial Conformity focuses on compliance with the Work Order Contract and fulfillment of the goals and needs agreed to by the region and funding program, as documented in Project Control documentation (Business Case, Project Charter, Approved Change Management Request). Technical Review focuses on compliance standards incorporated into the Work Order Contract by reference (Bridge Design Manual, Bridge CAD Manual, etc.).

When the ABR identifies an issue with conformity or a technical matter, they do not have authority to alter those requirements alone. Issues related to substantial conformity should be elevated to the CA. Neither the CA nor ABR have authority to authorize deviation for a technical matter. Technical non-conformity must be corrected at the project level or gain approval through a Design Deviation or Exception from the appropriate technical resource. Work with the ABR to gain approval for all structural related Design Deviations and Exceptions.

AGENCY BRIDGE REVIEWER (BRIDGE SPECIFIC PRICE AGREEMENT)

For in-house projects that are typically delivered by ODOT resources in Region Tech Centers, the Bridge Design Unit's contracting staff may be engaged to partially or completely outsource specific bridge design tasks that regions expect to be provided by the Bridge Design Unit. In these instances, the ABR duties will be performed by the CA and Agency Project Manager (APM). The purpose is to enable the Bridge Design Unit to fulfill its commitments, regardless of fluctuations in staffing and workload levels.

OUTSOURCED

The ODOT approved Quality Plan is outlined in the Work Order Contract. In order to gain approval, follow the ODOT Consultant Quality Plan Guidance found at <https://www.oregon.gov/odot/ProjectDel/QAQC/consultantQPguidance.pdf>.

Consultants shall direct all bridge design technical questions to the assigned ABR. If the ABR does not have specific experience or the consultant questions the response, set up a meeting with the ABR, appropriate Standards Engineer. Seek a workable solution and keep elevating until both ODOT and the consultant agree. If at any time the discussion changes from a technical matter to a contract issue, bring the CA into conversations. Document all decisions made either through a Design Deviation/Exception (if deviating from standard) or email (if meeting standard).

All bridge design work products being delivered by a consultant are reviewed by the ABR. *BDM 2.4* lists the most common deliverables that require undergoing the QV Process, ordered by milestone. This list is not exhaustive.

Table 2.5.6-1 Quality Verification Milestones

Milestone	Quality Documentation Required	Quality Review/Check Required
Project Initiation	QV Bridge A&E Review and Acceptance Checklist, <i>ODOT form 734-5371</i>	ABR signs
Project Development Phase start-up		
Design Verification Package (Completion of Project Initiation; POC)	QV Bridge A&E Review and Acceptance Checklist	ABR signs
Bridge TS&L Package	N/A	N/A
DAP/DAW	QV Bridge A&E Review and Acceptance Checklist	ABR signs
Preliminary Plans Package	QV Bridge A&E Review and Acceptance Checklist	ABR signs
Advance Plans Package	QV Bridge A&E Review and Acceptance Checklist	ABR signs
Final Plans Package	QV Bridge A&E Review and Acceptance Checklist	ABR signs
PS&E Package	QV Bridge A&E Review and Acceptance Checklist	ABR signs
	STR (Region Tech Center QV), <i>ODOT form 734-5365</i>	Manager or RBLE signs
Project Close-out		

2.5.7 Additional Bridge Quality Review Processes

There can be many different types of design reviews that aid in the development of quality products. The following are a few of the more typical reviews that may be done in conjunction with the above stated processes:

STATE BRIDGE/STATE PROGRAM/STANDARDS ENGINEER REVIEWS

For all Bridge Modernization Projects (In-house and outsourced designed) the design team will present the DVP or Proof of Concept/draft TS&L alternative analysis to the State Bridge Engineer, Program Manager and Standards Engineers, seeking their approval for the preferred alternative.

An internal review will be performed by the following personnel:

- State Bridge Engineer.
- Relevant Funding Program Manager, on selected projects.
- Bridge Standards Engineers; the outcome of this review is typically advisory comments or recommendations. The Standards Engineers may request to be involved on future

milestone reviews. Consultant designs are subject to the same additional design reviews as shown below.

See *Appendix C* for further details.

Consultant designs are subject to the above Bridge Section Internal Review of Bridge TS&L Reports. The design consultant will submit Bridge TS&L Report(s) to the A&E Agency Project Manager for distribution and review as described in the A&E WOC/Contract.

SUBJECT MATTER EXPERT AND BRIDGE PEER REVIEWS

For major projects involving unusual, complex, and innovative features, a peer review may be desirable to raise the level of confidence in the quality of design and construction. A peer review is generally a high-level review by a special panel of professionals specifically appointed by the State Bridge Engineer or designee to meet the demands for quality and accuracy, recognizing the complexity of the design. Peer review is an effective way to improve quality and to reduce the risk of errors and omissions. The need for such peer reviews is at the discretion of the State Bridge Engineer.

TPM/RE-CP (TECH CENTER/REGION QC) REVIEW

This review is completed after the Bridge discipline work is completed and the milestone deliverables are submitted to the Region. The TPM/RE-CP leads and distributes documents and completes this review as directed by the Region Technical Center Quality Plans. The Bridge Designer, reviewer and sometimes Standard Engineer(s) participate in this review. The focus is on cross-discipline integration rather than performing another round of Bridge specific QC.

REGIONAL BRIDGE LEAD ENGINEER AND STATE BRIDGE ENGINEER REVIEWS

A design review may be performed by the following personnel:

- RBLE
- State Bridge Design Engineer, on selected projects.
- RBLE may request Bridge Standards Section review (Subject Matter Expert review, including welding, protective systems), however, the outcome of this review is typically advisory comments or recommendations.

2.6 (Reserved)

2.7 QPL/Research

2.7.1 Qualified Products List (QPL)

The Structure Services Unit of the Construction Section is responsible for the evaluation of products for use on construction and maintenance projects. Products proposed cannot be approved by EOR. Only use projects on the *QPL* when applicable.

If a product is approved for use, it is included in the [Qualified Products List](#) (QPL) published every six months. The QPL is covered in [Section 00160.05](#) of the *ODOT Standard Specifications for Highway Construction* as modified by the special provisions. The special provisions of a project will identify which edition of the QPL is in effect for that contract.

A product can be evaluated as an **equal product** or a **new product**:

- Equal products are similar to ones currently used by ODOT and are covered by existing specifications or standards.
- New Products are ones not addressed by current specifications or standards.

After evaluation, a product's status becomes one of the following:

- Conditional – Equal or new product will be allowed a trial installation on one project only, recommended for a demonstration project, or recommended as an experimental feature.
- Qualified – Product is equal to existing approved products or has test results that meet ODOT specifications.
- Approved – Approved for use.
- Rejected - Product does not meet ODOT specifications or has failed performance testing.

Products with Conditional status will have trial installation on projects where they can be monitored during installation and for a limited performance period. The manufacturer or supplier is responsible for locating an active project, either construction or maintenance, for the proposed product. Normally, a product will be considered Conditional first, and then move to Qualified after it establishes a good track record. A previously qualified product can fall from grace and become rejected because of unsatisfactory field performance.

2.7.2 Research

(Reserved for future use)

2.8 Scoping

2.8.1 Introduction

ODOT performs a high-level scoping effort to help in the programming and funding of projects. This scoping effort determines the most likely project alternatives, documents assumptions and risk and develops a cost estimate. Bridge Section has a vital role in this effort to provide accurate information on bridges and other structures.

The following is direction specifically for ODOT bridge discipline. For additional information refer to the [ODOT Scoping Manual](#) for process information.

2.8.2 Local Agency

Scope local agency projects per standards requirements in *BDM 1.2.3.6*.

2.8.3 Bridge Scoping Tool (BST)

The BST is used to populate the Smartsheets housed within the TPMS (Transportation Project Management System) and develop a bid item driven scoping cost estimate.

Directions for use of the BST are in *Figure 2.8.3-1*.

Figure 2.8.3-1 Bridge Scoping Tool Directions

Step 1

In the [1. Narrative] tab, complete the header information.

BRIDGE SCOPING NARRATIVE			
Project Name	OR39 N. Klamath Interchange to S. 6th St	Scoping No.	2730-00050
Bridge Design Category	Bridge Retrofit		
Scoped by	Ben Pung	Scoping Date	6/24/2024
Reviewed by	Paul Strauser	Review Date	6/27/2024

Step 2

In the [1. Narrative] tab, under 'Bridge No.' use pulldown list to select bridge numbers included in project.

The Structure Name, Highway, and MP will auto-populate.

Bridge No.	Structure Name	Highway	MP
18276	USBS Main Canal A, Hwy 50	OR 39 (HWY 050)	1.57
02716A	Lost River Diversion Canal, Hwy 50	OR 39 (HWY 050)	3.81

Step 3

In the [1. Narrative] tab, complete the Narrative, Assumptions, and Risks Sections.

Note: Ensure risks are written in "If..., Then...." format.

Narrative
 BR18276 (USBS Main Canal A, Hwy 50) is a single span (102'-0") PS box girder bridge with a 44'-0" Roadway. The bridge has an 2 tube side mount bridge rail.
 The bridge is located in snow area and receives heavy deicing and plow traffic.
 The 08/10/2019 Bridge Inspection Report shows a Deck Condition State of 3-Fair with several concrete patches, exposed reinforcing, and severe cracking. The bridge has a controlling Rating Factor of 1.15 for Moment in the exterior girder.
 The Scope of the project is to raise the deck condition to Good and repair joints.
 It is proposed to place a Structural Overlay on the deck and replace joints in kind.

Assumptions
 The following assumptions were made during scoping:
 -Advanced Investigation per RDM 1.9.4.4. will be conducted to determine the chloride levels or other chemicals of interest.
 -Traffic can be placed and maintained in a two-way single 16'-0" wide lane during the duration of the rehabilitation work. This lane would be separated from the work with a concrete barrier.

Risks
 The following risks were identified during scoping:
 - If traffic volumes or mobility are such that traffic cannot be placed in a single lane, then a detour or other method of traffic control or an alternate overlay material will need to be used which could increase project cost and timelines.
 - If the Load Rating shows that the bridge cannot handle additional Dead Load from the structural overlay, then a concrete inlay or strengthening will be required which would increase project cost and timelines.

Step 4

In the [1. Narrative] tab, add relevant sketches and photos



Step 5

In the [3. Est] tab, Using the pull down menus, select the 'BRIDGE No.', 'SPEC GROUP', & 'SPEC' for each bid item required for the scoping estimate

ITEM No.	BRIDGE No.	SPEC GROUP	SPEC	MEASURE
0010	18276	0500 - Bridges	0501-0100000A - BRIDGE REMOVAL WORK	SQFT
0020	18276	0500 - Bridges	0504-0100000J - CLASS 2 PREPARATION	SQYD
0030	18276	0500 - Bridges	0559-0300000K - STRUCTURAL CONCRETE OVERLAY MATERIAL	CUYD
0040	18276	0500 - Bridges	0559-0302000L - CONSTRUCT STRUCTURAL CONCRETE OVERLAY	SQYD
0050	18276	0500 - Bridges	0559-0401000M - SAW CUT TEXTURING	SQYD

Note: The 'ESTIMATED ITEMS' and 'BID ITEMS' cells will autopopulate when the bid item in the 'SPEC' pull down is selected.

Note: Complete the 'NOTES' cell as needed to better describe the bid items

ITEM No.	BRIDGE No.	SPEC GROUP	SPEC	MEASURE	ESTIMATED QUANTITY		BID QUANTITY		TOTAL	UNIT COST	TOTAL COST	NOTES
					QTY	UNIT COST	QTY	UNIT COST				
0010	18276	0500 - Bridges	0501-0100000A - BRIDGE REMOVAL WORK	SQFT	1.00	\$0.00	0.00	\$0.00	1.00			
0020	18276	0500 - Bridges	0504-0100000J - CLASS 2 PREPARATION	SQYD	21.07	\$0.00	0.00	\$0.00	21.07			
0030	18276	0500 - Bridges	0559-0300000K - STRUCTURAL CONCRETE OVERLAY MATERIAL	CUYD	14.44	\$0.00	0.00	\$0.00	14.44			
0040	18276	0500 - Bridges	0559-0302000L - CONSTRUCT STRUCTURAL CONCRETE OVERLAY	SQYD	0.00	\$0.00	0.00	\$0.00	0.00			
0050	18276	0500 - Bridges	0559-0401000M - SAW CUT TEXTURING	SQYD	0.00	\$0.00	0.00	\$0.00	0.00			

Step 6

In the [3. Qty] tab, calculate estimated quantities for each bid item. Ensure the quantity is reference in the boxed cell.

Note: It is important to clearly document how quantities are calculated.

The quantities referenced in the boxed cell will populate the 'QTY' in the '3. Est' tab.

Item Number	Bridge Number	Spec. Number	Item Description	Quantity					Spec Unit		
				Item	Qty	Unit	Number	Total			
0050	18276	0559-0300000K	STRUCTURAL CONCRETE OVERLAY MATERIAL							31.42	CUYD
				L =	102.25	F	Length of bridge				
				W =	44.00	F	Deck Width				
				T =	2.25	F	Assumed overlay thickness				
				V =	31.42	CV	Structural concrete volume				

Step 7

In the [2. Smartsheet Data] tab, click the [Smartsheet](#) link in the upper right corner to navigate to the Bridge Scoping Smartsheet, where the scoping data is documented.

SMARTSHEET DATA INPUT

Project Name OR39 N. Klamath Interchange to 8.6th St **Scoping No.** 2730-000

Bridge Contact(s)
List designer(s) performing scoping and Region Bridge Lead Engineer (RBLE) for the Region if they are not otherwise a member of the scoping team.

Region 4
Scoped by Ben Pung, Reviewed by Paul Strauser, R4 RBLE is Paul Strauser

Notes

[Smartsheet](#)

Step 8

Select the project from the list to open the Bridge Scoping Smartsheet.

The Smartsheet includes entry fields for items including 'Bridge Contact(s)', 'Structure Number(s)', etc.

The [2. Smartsheet Data] tab has autopopulated cells corresponding to the Smartsheet entry fields.

Highlight and copy the corresponding cells in Excel file and paste into the Smartsheet entry fields to complete the Smartsheet.

Narrative, Assumptions & Risks - Executive Summary

Executive summary of all work on all bridge for the scoping project. Copy from Bridge Scoping Tool (BST).

NARRATIVE
BR18276 (17025 Main Canal A, Hwy 60) is a single span (182'-0") PS box girder bridge with a 44'-0" Roadway. The bridge has an 2' take side access bridge and.

The bridge is located in areas with moderate heavy-duty driving and slow traffic.

The 06/10/2019 Bridge Inspection Report shows a Deck Condition Score of 5-Fair with several concrete patches, exposed reinforcing, and severe cracking. The bridge has a controlling Rating Factor of 1.13 for Moment in the exterior girder.

Bridge Narrative, Assumptions, & Risks

Executive summary of all work on all bridge for the scoping project. Copy from Bridge Scoping Tool (BST).

NARRATIVE
BR18276 (17025 Main Canal A, Hwy 60) is a single span (182'-0") PS box girder bridge with a 44'-0" Roadway. The bridge has an 2' take side access bridge and.

The bridge is located in areas with moderate heavy-duty driving and slow traffic.

The 06/10/2019 Bridge Inspection Report shows a Deck Condition Score of 5-Fair with several concrete patches, exposed reinforcing, and severe cracking. The bridge has a controlling Rating Factor of 1.13 for Moment in the exterior girder.

The scope of the project is to raise the deck condition to Good and repair joints.

It is proposed to place a Structural Overlay on the deck and replace joints in kind.

Assumptions
The following assumptions were made during scoping:
Advanced investigation per BDM 3.9.4.6 will be conducted to determine the relative levels or other alternatives of interest.
Traffic can be placed and maintained in a two-way single 10'-0" wide lane during the duration of the stabilization work. This lane would be separated from the work with a concrete barrier.

2.9 TS&L and DAP

2.9.1 Introduction

Project Development Phase (aka, DAP Design Phase) is the phase between the milestones Project Initiation (Kickoff) and Design Acceptance Package (DAP). The Project Development Phase concludes with the acceptance of the DAP. When the project includes bridge structures, the DAP will include a section for Bridges.

The Bridge Criteria & Standards Assessment is the first deliverable provided by the designer in this phase, establishing the framework within which the bridge work is designed.

Bridge TS&L Report development provides the opportunity for the State Bridge Engineer and delegated Bridge Personnel to have input on the type of bridge, or work affecting the bridge, under design on Bridge Modernization Category projects.

Consider the bridge location, length, width, span arrangement and superstructure system considering practical design measures, traffic requirements, safety measures, channel configuration, stream flow, etc in the alternatives analysis. Identify and assess feasible alternatives for a proposed bridge crossing along with their merits and shortcomings, in the Design Alternative Scoring Matrix.

The Bridge Strategy Memo provides a description of the different bridge features being modified or replaced on a Bridge Retrofit Category project, along with a brief exploration of the selected retrofit method for each feature.

2.9.2 Bridge Design Criteria & Standards Assessment

The bridge Design Criteria & Standards Assessment (DCSA) is required for all projects with work on bridges. Document the following in the DCSA:

- Specifications, manuals, and codes. Identify each by version. Refer to *BDM 1.2.1.1*.
- References to relevant standards, guidance, standard drawings, and standard details.
- Whether the design is compliant or non-compliant with standards. Document items that are most relevant to the layout and design of the proposed work.
- Whether a design deviation or design exception is necessary for non-compliant elements. Technical concurrence is only required when a design deviation or exception is necessary.
- The status of required design deviations and exceptions.
- When not documented in a design deviation, relevant notes such as how the standard is fulfilled, why deviation from standard is necessary or beneficial, and summaries of correspondence with ODOT Technical Resources & Agency Bridge Reviewers.
- Deck treatments on all existing state-owned structures, including overlay type, joint modifications, thickness and material types. All deck treatment selections must be given a line on the DCSA. Input from the Structural Materials Engineer is required.

Store relevant correspondence in ProjectWise Structure folder. Correspondence is necessary when:

- Required by the *BDM*.
- The Engineer of Record considers it necessary or beneficial to deviate from standards.
- A standard or guidance requires clarification.
- The standard is absent and a project specific standard is needed.

Complete the first draft of the DCSA during project initiation, as specified in the BDWO (In-House Design) or SOW (Outsourced Design). This documents current design criteria and standards to be used during the Project Development Phase. The DCSA is a living document and this is only the initial version, not intended to include comprehensive project information.

Continue to refine the DCSA during the Project Development Phase and submit with the Bridge TS&L Package and Design Acceptance Package.

On Bridge Preservation Category projects, submit the DCSA to accompany the Design Narrative. Update the list of relevant specifications and standard versions to document the design criteria and standards to be used from DAP through the end of the Project Design Phase.

Continue to refine the DCSA during the Project Design Phase and include the DCSA in the Bridge Calculation Book. Issues related to standards are expected to be resolved by the DAP Phase Gate and as such, the DCSA is not identified as a formal deliverable for milestones in the Project Design Phase. When changes in scope or issues related to standards arise in the Project Design Phase document according to project management best practice.

The Agency's DCSA template (<https://www.oregon.gov/odot/Bridge/Pages/Bridge-Forms.aspx>) is required for in-house design. For outsourced design, Consultants may use the Agency's template or a Consultant prepared form that serves the same function.

2.9.3 Design Deviations and Exceptions

The DCSA will be reviewed by the Bridge Reviewer (In-House Projects) or Agency Bridge Reviewer (Outsourced Projects) and Technical Resources, when appropriate (all projects). When required, prepare design deviations or exceptions. See *BDM 1.2.2*. Include approved design deviations and exceptions in the calculation book.

2.9.4 Bridge TS&L Package

The Bridge TS&L Package is comprised of:

- Bridge TS&L Report or Bridge Strategy Memo.
- Engineer's Estimate at TS&L.
- Bridge TS&L Plan Sheet(s).
- Bridge Design Criteria & Standards Assessment.
- Draft Design Deviations and Exceptions.
- Pre-Design Load Rating, where required.

2.9.5 Bridge TS&L Report

2.9.5.1 Purpose of the Bridge TS&L Report

The purpose of a Bridge TS&L Report is to document:

- Alternatives studied or reasonable alternatives/options considered in the Design Alternative Scoring Matrix.
- Recommended alternative (or option), and the **approved** alternative advanced to the Project Design Phase.
- Rationale for **why** the recommended and **approved** alternative(s) or option(s) was(were) selected over the other alternatives or options.
- Selected type, geometry, size, and location of the recommended and **approved** alternative or option.
- Deviations from design practices.
- Background information on rationale for reviewers, owners, or clients to effectively evaluate and approve an alternative to advance to Post-DAP final design.

Provide just enough information to address each discussion item as a bridge designer; typically it is not necessary or desirable to provide the supporting information used by other disciplines (i.e., biologists, hazmat specialists, roadway engineers, traffic engineers, historians, etc.).

C2.9.5.1

There may be a misconception that the Bridge TS&L Report is prepared so that the Bridge Hydraulics Report, Geotechnical Subsurface Exploration, and Preliminary Geotechnical Reports can be prepared. In actuality, each of these documents should be prepared at the same time with each document preparer working in close coordination and collaboration with the other document preparers.

A Bridge TS&L Report provides specific bridge information required by FHWA for their review and approval of projects using Federal funding (and recommended for projects without Federal funds). It is the concluding documentation of the Alternatives Study. The name was coined by FHWA circa 1990. The acronym TS&L stands for Type, Size & Location. The FHWA/ODOT Stewardship Agreement of the Federal Aid Program has delegated the TS&L review and approval process to ODOT for federal-aid projects that are designated as NOT Full Federal Oversight (FFO). ODOT will submit Bridge TS&L Reports to the FHWA on projects designated as FFO.

If adequate background information is NOT provided the Bridge TS&L Report may be rejected, which could result in an undesirable delay in the project schedule.

Bridge Section makes a distinction between the Bridge TS&L and the DAP. The Bridge

TS&L is used as the approval document for the bridge discipline. The DAP is the approval document for the entire project. The duties of the Bridge Reviewer (QC) include official approval of the Bridge TS&L for the bridge discipline.

The DAP submittal provides ODOT the opportunity to officially **approve** a developing project. However, since it includes the entire project, review of this submittal is typically higher level, focusing on project footprint rather than individual structures. For this reason, the primary Quality Control requirements for the bridge discipline are focused on the Bridge TS&L.

To ensure an appropriate review of the Bridge TS&L, adequate time in the schedule is necessary to allow modifications to the design and revisions of the Bridge TS&L prior to submittal of the DAP.

2.9.5.2 When is a Bridge TS&L Report needed?

A Bridge TS&L Report is required for Bridge Modernization Category work. The required components of a Bridge TS&L Report are discussed in [BDM 2.9.5.5](#).

2.9.5.3 Bridge TS&L Approval (In-House Design)

Under the direction of a State Bridge Design Engineer, the Bridge Reviewer (and a Bridge Section Internal Reviewer when identified) will review and approve the Bridge TS&L Report. The Bridge TS&L Report will be signed by both the Bridge Designer and the Bridge Reviewer. The Bridge Reviewer's signature will constitute **approval** of the Bridge TS&L by a person knowledgeable in bridge design.

See [Appendix C](#) for more details of this review and approval process.

Multiple Bridge Projects and the Bridge TS&L Report

For projects with more than one bridge structure, create a separate section/chapter within the same Bridge TS&L Report for each bridge structure. Creating a separate section/chapter for each bridge will make it easier to:

- Add or subtract bridges, should the scope change.
- Focus discussions on individual bridges.
- Not have to flip through pages of information on other bridges that are not relevant to the bridge of interest.

2.9.5.5 Components of a Bridge TS&L Report

1. Cover Page
2. Signature Page
3. Table of Contents
4. Body of Narrative,
 - a. Project Information (location)
 - b. Bridge Alternatives Study
 - c. Design Alternatives Scoring Matrix
 - d. Recommended Alternative
 - e. Accelerated Bridge Decision Criteria
 - f. ADA Compliance
 - g. Mobility (AADT, # lanes to remain open, detours)
 - h. Roadway (horizontal & vertical alignment, superelevation, roadway x-section)
 - i. Hydraulics (design flood, ordinary high water, scour)
 - j. Geotechnical & Foundations (subsurface conditions)
 - k. Environmental Information & Constraints, related to the bridge design
 - l. Traffic (signs, signals, illumination), attached to the bridge
 - m. Utilities (on bridge, near bridge)
 - n. Railroad (clearances)
 - o. Right of Way (temporary and permanent), related to the bridge
 - p. Superstructure (type, geometry, length, width, clearances)
 - q. Substructure (type, geometry, size, clearances)
 - r. Preliminary Bent Loads
 - s. Aesthetics
 - t. Other Design Justification (if rationale for decisions made is not provided above)

Tables and figures are an integral part of a well-written Bridge TS&L Report. If the text is crowded with detail, especially quantitative detail, consider creating a table. Do not overload the text with information that could be presented better in a table. Tables are often used for reporting extensive numerical data in an organized manner.

If the Hydraulics Report or Geotechnical Report are not available at the time the Bridge TS&L Report is written, always include comments about assumptions made in consultation with the

hydraulics or geotechnical designer. Ensure these assumptions stand out in the narrative, identifying the risks assumed by continuing the bridge design without vetted design information.

Do not use the Bridge TS&L Report to provide all the data needed for environmental permitting. Include this permitting information in a separate memo. See [BDM 2.14.8](#) for further guidance.

2.9.5.6 Bridge Alternatives Study

Refer to [Appendix C](#) for detailed guidance. Bridge Strategy Memo

2.9.6 Bridge Strategy Memo

2.9.6.1 Purpose of the Bridge Strategy Memo

The purpose of a Bridge Strategy Memo is to document the:

- Proposed work on bridges in the Bridge Retrofit Category;
- Rationale for the recommended and **approved** option(s) selected;
- Deviations from standard design practices;
- Results of Pre-Design Load Ratings.

2.9.6.2 When is a Bridge Strategy Memo needed?

A Bridge Strategy Memo is required when the Bridge Design Category is Bridge Retrofit, see [BDM 1.2.3.3](#).

C2.9.6.1

The Bridge Strategy Memo was created by the Bridge Section at the same time Bridge Design Categories was introduced (May 2021). The Bridge Strategy Memo was introduced as a means to write a simpler document than a Bridge TS&L for bridge work that did not require the full Bridge TS&L Report.

C2.9.6.2

If the scope of work at the end of the Project Development Phase is the same as the scope of work at the beginning of the Project Development Phase the Bridge Strategy Memo will simply document that the scope is the same. If the scope of work at the end of the Project Development Phase has changed, the Bridge Strategy Memo should document the reasons why the scope has changed. The primary reason for the Bridge Strategy Memo is to establish a baseline of project scope prior to proceeding to post-DAP final design.

2.9.6.3 Bridge Strategy Memo Approval

IN-HOUSE DESIGN

Under the direction of the State Bridge Design Engineer, the Bridge Reviewer will review and approve the Bridge Strategy Memo. The Bridge Strategy Memo will be

signed by both the Bridge Designer and the Bridge Reviewer. The Bridge Reviewer's signature will constitute **approval** of the Bridge Strategy Memo by a person knowledgeable in bridge design.

OUTSOURCED DESIGN

(Reserved for future use)

2.9.6.4 Multiple Bridge Projects and the Bridge Strategy Memo

For projects with more than one bridge structure, create a separate section/chapter within the same Bridge TS&L Report for each bridge structure.

2.9.6.5 Bridge Strategy Memo Contents

- Body of Memo
 - Project Information (location)
 - Bridge Options Study
 - Selected Retrofits
 - Rationale for changes in scope
- When any of the following are considered to be a risk to a project, include relevant information in the Project Information:
 - Historic preservation requirements / ADA Compliance
 - Park land impacts
 - Deck condition and chloride content
 - Staging of the work
 - Load rating status (i.e., should the bridge be strengthened as part of the project, and can the bridge support any needed work access or other temporary works?)
 - Items from the list in *BDM 2.9.5.5*:
 - Mobility.

C2.9.6.3

For Bridge Program funded bridge projects, it is very important for the Reviewer to have the concurrence of the Bridge Standards and Program Manager and the State Bridge Engineer on final scope before approving and proceeding to Post-DAP final design. When scope in Bridge Strategy Memo does not match Final Business Case, confirm with Bridge Standards and Program Manager as soon as possible.

- Environmental Information & Constraints.
- Utilities.
- Railroad.

2.9.6.6 Bridge Options Study

Sometimes bridge retrofit work has options. When relevant, document the options study and reference in the Bridge Strategy Memo. Include this study documentation in ProjectWise.

2.9.7 Engineer's Estimate at TS&L

The Engineer's Estimate at TS&L documents the estimated construction cost of the preferred alternative. Prepare an itemized estimate for each alternative studied. Base the estimate on calculation of quantities based on the preliminary design and documented assumptions. Include all alternative estimates in Bridge TS&L Submittal.

2.9.8 Bridge TS&L Plan Sheets

The Bridge TS&L Plan & Elevation Drawing(s) contains the following items, where applicable:

- Title Block.
- Vicinity Map (with north arrow).
- Plan View (with north arrow).
- Elevation View.
- Typical Section.
- Bent Elevation(s).
- Grade Diagram.
- Construction Staging Section(s).
- Hydraulic Data.
- Bridge TS&L General Notes.

Additional sheets may be included to show bent elevation and construction staging typical sections, when significant/applicable.

See *Bridge CAD Manual* for specific information pertaining to the drafting and detailing of the Bridge TS&L Plan & Elevation drawing.

Include plan sheet(s) in the Bridge TS&L Package.

2.10 Project Design/PS&E

2.10.1 Introduction

The Project Design Phase begins after receiving approval of the DAP. For Design-Bid-Build projects, the Contract Documents are prepared during the Project Design Phase. These documents include sealed and signed contract plan sheets, Special Provisions, Engineer's Estimate, and estimates of probable construction schedule. Other bridge deliverables prepared during the Project Design Phase may include calculation books, the bridge load rating, and Operation and Maintenance manuals.

2.10.2 Sealing & Signing Requirements

[ORS 672.002\(10\)](#) requires the stamping engineer to be in **responsible charge**; that is, to have supervision and control of the work.

The Bridge Engineer of Record is to seal and sign the final digital Bridge drawings; other roles noted on the drawing may be signed or printed. Current practice requires only one stamp on the plans. (Refer to [TSB11-02D](#))

The Bridge Engineer of Record or the Bridge Designer (when registered) is to seal and sign other applicable work products per [TSB11-02D](#). (ODOT Intranet link: [DES 05-02](#))

It is expected that a person possessing a professional engineer's license in the State of Oregon will seal and sign their own work.

See ODOT Technical Services [Professional of Record Guidance](#) for further guidance.

2.10.3 Contract Plans

2.10.3.1 At Preliminary Plans

Start all plan sheets and show gross geometry of the elements. Start details if information is available; however, it is not necessary to have all details shown at this time.

2.10.3.2 At Advance Plans

Complete **unchecked** plan sheets. All geometry and details are to be shown at this time. Prepare Check Print set of plan sheets for the Bridge Checker and the Bridge Reviewer.

2.10.3.3 At Final Plans

Corrected plan sheets based on resolution of QC Check comments. Prepare digital plan sheets for signatures.

2.10.3.4 At PS&E Package

Clear and complete detailed plans with information necessary to obtain a fair bid and to layout and construct the project.

2.10.4 Specifications & Special Provisions**2.10.4.1 At Preliminary Plans**

Unique special provisions will be identified in the Engineers Estimate file.

2.10.4.2 At Advance Plans

Complete a draft of the Special Provision package.

2.10.4.3 At Final Plans > Final Special Provisions

Complete the final Special Provision package.

2.10.4.4 At PS&E Package

Specifications, Supplemental Specifications, and Special Provisions necessary for construction of the project.

2.10.5 Engineer's Estimate**2.10.5.1 At Preliminary Plans**

Calculated quantities of materials in the project, based upon the current Bid Item list.

2.10.5.2 At Advance Plans

Calculated quantities of materials in the project, based upon the current Bid Item list.

2.10.5.3 At Final Plans

Calculated quantities of materials in the project, based upon the current Bid Item list.

2.10.5.4 At PS&E Package

Calculated quantities of materials in the project, based upon the current Bid Item list. Estimate of the cost of design assistance during construction.

2.10.6 Engineer’s Estimate of Probable Construction Schedule

A Project Construction Schedule is required to be submitted with the PS&E Package per 4.2.i of the [Phase Gate Delivery Manual](#). The contribution from bridge design will vary based on Region and project.

2.10.6.1 At Preliminary Plans

Not applicable.

2.10.6.2 At Advance Plans

Refer to the *Phase Gate Delivery Manual*, and prepare and submit a draft of the estimated probable construction schedule for the bridge or structure construction for review when required by the project team.

2.10.6.3 At Final Plans

Update the estimated schedule, and submit a final copy when required by the project team.

2.10.6.4 At PS&E Package

Not applicable. (A complete Project Construction Schedule, including the bridge and structure work will be submitted to the Project Controls Office by the TPM or RE-CP.)

2.10.7 Calculations & Calculation Books

2.10.7.1 Types of Calculations

- Geometry.
- Structural.
- Quantity.
- Designer’s Calculations – A structural analysis and design of the bridge and related components. Documentation of the work with hand calculations, computer output and detailed notes. The Design Engineer is responsible for the meaning and applicability of computer generated data.
- Design Check Calculations – A check of: the structural analysis and design of the bridge and related components, plan detail sheets, specifications and special provisions, and project quantities; Document the work with hand calculations, and computer output and detailed notes.

2.10.7.2 Importance of Calculations

Designers are responsible for well-organized, legible, neat design calculations properly assembled in a calculation book. Remember: **YOUR CALCULATION BOOK COULD BECOME AN EXHIBIT IN THE COURTROOM.**

Be selective, including only calculations that support what the contract plans show. Do not include calculations that led down the wrong path and are not shown on the contract plans. However, calculation sheets voided by a project **redo** should not be discarded/deleted, but stored outside of the calculation book, until it is certain they are no longer needed.

2.10.7.2.1 Submittal

Internally to ODOT, calculation books are a living document and reside in the appropriate PW folder. Add calculations to the book as developed, and compile calculation books at each project milestone submission. Submit calculation books with deliverables according to *BDM 2.4*.

After the design phase of a project is completed and the project is awarded, submit a calculation book for archiving. Submit electronic calculation book(s) to ODOT Bridge Section at the Bridge Design Project Close Out.

Email the ProjectWise URN link for the completed calculation book to: ODOTBridgeEngineeringSection@odot.oregon.gov.

Update calculation books when design changes occur during construction. See *BDM 2.12.5.2* for additional guidance.

The Bridge Section maintains the archiving process for all pertinent design/check calculations for documentation and future reference.

C2.10.7.2.1

For projects prior to October 2017, submit the electronic (contained in CD or USB thumb drive) calculation book to:

ODOT Bridge Engineering Section
4040 Fairview Industrial Drive SE, MS #4
Salem, OR 97302

2.10.7.3 Calculation Books

For a bridge, the paperwork (usually excluding most correspondence) generated by the final design and construction stages becomes a **set of calculations**, or a Calculation Book. Typically for a bridge, a calculation book includes:

- Cover Sheet.
- Table of Contents.
- Designer’s QC Form.
- Updated Bridge Design Standards Assessment Table.
- Updated Design Criteria.
- Approved Design Deviations/Exceptions.
- Structural calculations.
- Quantity calculations.
- Checked Engineer’s Estimate @ Final Plans.
- Final Engineer’s Estimate of Probable Construction Schedule.
- Construction stage calculations such as falsework calculations, alternate design checks, and design corrections or revisions.
- Copies of Project Discussion Memos relevant to the calculations.
- Checker QC documents (calculations, QC Form, quantities) as an Appendix (unless required as a separate calculation book).

In the above lists, if it does not say “copy”, it means use the original.

Calculation books must:

- Contain work from only one project. Request a different calculation book number for each project.
- Contain work from only one EOR, with the exception of documents in the Appendices. Calculation books can contain work from multiple EORs when they are working on different parts of the same structure, on the same project.
- Contain work for only one bridge when substantial structural analysis is required. Calculation books can contain work for multiple bridges when only minor or no structural analysis is required. If the expectation is unclear, clarify when creating the Bridge Design Work Order or SOW and document accordingly.
- Have a PE stamp and signature.

Separate checker calculation books must follow the same rules as calculation books listed above. Checker calculation books are required under the following circumstances:

- When required by SOW.
- As requested by the State Bridge Engineer.

When a separate checker calculation book is not required, include checker QC documents (calculations, QC forms, quantities) as an Appendix to the calculation book. Checker QC documents do not need a PE stamp.

Calculations for bridge load rating are handled differently from design calculations. Load rating calculations have their own calculation book and naming convention. For details, refer to the *ODOT LRFR Manual 22.1.1*.

2.10.7.4 Calculation Book Cover Sheet

The first sheet of every set of design calculations is a completed Calculation Book Cover Sheet. This sheet must contain the calculation book number and a PE stamp with signature. Digital signatures are acceptable.

2.10.7.5 Table of Contents

Take time to tie calculation pages together by careful cross-referencing.

2.10.7.6 Calculation Sheets

Fill out all headings completely for each sheet used. You may want to number the sheets of a set with its own sequence of numbers while working on an assignment, but you will need to renumber with page numbers in the upper right corners when the set is bound into a calculation book.

To make your calculations understandable later:

- Put them in logical order.
- Show design assumptions.
- Show formulas complete with references.
- Reference the source of any numbers taken from other calculations.
- Reference Design Deviations.

2.10.7.7 Other Calculation Material

Make sure other material such as computer output, diagrams on graph paper, or completed forms also have the same identifying information as the calculation sheets.

2.10.7.8 Calculation Book Numbers

Each calculation book has its own number. See *BDM 2.10.7.3* for additional guidance.

Calculation book numbers are requested from and assigned by the Bridge Section. When requesting a calculation book number, fill out the request form at:

[Calculation Book Number Request Form](#)

At the time Advance Plans are first distributed for review, the designer will need a calculation book number for the title blocks of the drawings.

Although more than one book may be used for a project with several bridges, do not reserve additional book numbers when requesting the first one. Book numbers for a project with several

bridges are not required to run consecutively. Request additional book numbers when needed or when preparing a set or sets of calculations.

2.10.8 Bridge Load Ratings

All Oregon bridges, regardless of ownership, are rated following the *ODOT Load and Resistance Factor Rating* procedures outlined in the *ODOT LRFR Manual*.

Load rating calculations have their own calculation book and naming convention. For details, refer to the *ODOT LRFR Manual 22.1.1*.

The following subsections define practices for Existing, Pre-Design, Final Design, and Stamped Load Ratings delivered with construction projects. Compress load rating files into a single folder (ZIP format) for storage in ProjectWise. This format has been approved to enhance productivity and clarity. As a load rating develops over the course of a project, version the folder for each iteration and update the description of the new version accordingly.

Refer to *BDM 1.12.6* for load rating requirements of utility installations.

2.10.8.1 Existing and Pre-Design Load Ratings

Contact Bridge Engineering Section (ODOTBridgeEngineeringSection@odot.oregon.gov) for a copy of existing load rating(s) whenever Bridge Retrofit or Bridge Modernization work will alter the load carrying capacity of or demand on an existing bridge. Review existing load rating(s), Bridge Inspection Reports, and understand risks related to alterations.

Update an existing load rating per *ODOT LRFR Manual Section 1.7*. Notify the Senior Load Rating Engineer whenever a load rating update will be delivered as part of a project. When alterations to an existing bridge require updates to an existing load rating, perform a Pre-Design Load Rating of the proposed condition during project initiation per *BDM 2.3.2*.

Use Pre-Design Load Rating results to inform decisions during Bridge TS&L Package development. Results may demonstrate that the bridge is suitable for the proposed condition without restriction or identify critical rating factors and a need for further action. For load ratings associated with a project going to construction, proceed with a final design load rating to address critical rating factors with additional analysis, testing, or strengthening to minimize the risk of load restrictions for legal and permit vehicles after completion of the project. Follow-up actions vary by project, but typically include one or multiple of the following items:

- Considering alternatives to the proposed condition.
- Applying simple load rating refinements. See *ODOT LRFR Manual Section 1.6* for guidance. When rounding is recommended, obtain approval via design deviation. Include information regarding the cost to strengthen and likelihood of future load restriction.

- Communication with ODOT’s Load Rating Unit to determine the suitability of complex load rating refinements. Contact the Senior Load Rating Engineer. Document this correspondence and the outcome in the DCSA.
- Material testing. See *BDM 1.15.1.1* and *ODOT LRFR Manual Section 1.6*.
- Strengthening when feasible, cost effective, and prudent. See *BDM 1.15.1.1* and *BDM 1.3.3.4* for strengthening requirements.
- Obtaining approval via design deviation to accept the load restriction.

2.10.8.2 Final Design and Stamped Load Ratings

Complete Final Design Load Rating(s) near PS&E whenever Bridge Modernization or Bridge Retrofit work requires a new load rating or updates to an existing load rating.

When bridge construction is complete, update load rating(s) for as-constructed changes, when necessary, and submit the Stamped Bridge Load Rating per the *ODOT LRFR Manual*.

2.10.9 Operations and Maintenance Manuals

Bridge engineering has been changing and numerous emerging technologies are on the horizons that enable facility owners to improve the performance and to monitor the safety of their bridges. To ensure these innovations are properly applied and monitored for their effectiveness, the owner is requiring Operations and Maintenance manuals to be submitted along with the design calculations for all unconventional, complex or unusual systems or details. The specifics of the service manuals will be determined at the beginning of design of which they relate to the bridge type design selected.

The intent of this provision is to provide additional information to the agency for the efficient and effective operation of any innovations that are installed and specific to a facility. The manual may include shop drawings, fabrication details and manufacturer’s technical product information. The manual should be clear in providing instructions on how and when to inspect and maintain the systems or details and how often to perform condition assessment of the unit.

Examples of deliverables:

1. NDT/E Monitoring Systems:
 - a. Example of deliverable: Operations and Maintenance Manual for all the NDT/E monitoring systems for recording fracture critical stresses and potential fatigue crack locations
2. Electrical and Mechanical Systems on Movable Bridges
 - a. Operations and Maintenance Service Manuals for the all electrical controls on movable bridges. Maintenance manual should include servicing the machine components and gears, brake systems, drive motors and span locks.
 - b. Operating instructions should include electrical service disconnect, wiring and labeling of electrical power distributions, traffic control systems, span lift control

and lock systems, navigational and channel lightings, HVAC, fire and security alarms, and remote camera and sensing systems.

3. Seismic Monitoring Systems:
 - a. Operations and Maintenance Manual for seismic monitoring system for recording ground motions.
 - b. Operating instructions should include system inspection and checks, recorder working properly, troubleshooting, and accelerometers working condition.
4. Cathodic Protection Systems:
 - a. Operations and Maintenance Manual for all cathodic protection system to include such components like cabinets, wiring system, reference cells, anodes, and terminal plates.
 - b. Operating instructions should include system and inspection checks, battery power operated checks, trouble shooting, presence of corrosion, and sensors integrity check.
5. Bridge design types that are unique or unconventional to Oregon:
 - a. Segmental and cable stayed bridges – inspection and maintenance manuals for its critical details and main force carrying components. Such examples include post-tensioning ducts and tendons, stay cables, anchorage and cradle details, deviators, pot bearings, modular joints, seismic isolation and damping devices, wind shear locks. Maintenance instructions should include the inspection and replacement of its components when they are no longer performing as designed.
 - b. Suspension bridges – inspection and maintenance manual for its critical details and main force carrying components. Such examples include main cable, saddles, anchorages, shoes, suspender ropes, corrosion protection systems, seismic isolation and damping devices, and wind shear locks.

2.11 PS&E to Award

2.11.1 Introduction

See [PDLT Operational Notice PD-07](#).

See [PDLT Operational Notice PD-08](#).

2.11.2 Changes to Bridge Deliverables after PS&E

Avoid drawing and estimate revisions after the Bridge Designer has signed the Final Plans. The Project Controls Office needs a minimum of 31 calendar days prior to the advertising date for final preparation, review, and printing of the contract documents.

The Bridge Designer is responsible to see that any late changes are made and carefully documented. If a drawing is added to the Bridge Final Plans after a project is advertised, the roadway designer must be notified so that the drawing number can be added to the title sheet of the contract plans.

Although every attempt should be made to wait until after the contract is awarded, essential changes to the plans and special provisions, that would significantly affect the contract cost or character of the work, can be made during the advertisement period, by an Addendum Letter, up to 10 days before the bid opening, or letting, date.

2.11.3 Bridge Design Project Close-Out

When the project contract is awarded, the Bridge Designer submits with Project Wise the following:

- Structural Analysis Input/Output Files.
- CAD files.
- Structure Cost Data.
- Seismic Design/Retrofit Data Sheet located at:
<https://www.oregon.gov/ODOT/Bridge/Pages/Seismic.aspx>

2.11.4 Request for Information (RFI)

(Under Development)

2.11.5 Addenda Letters

For more information on Addenda, see *Section 6* of the [Project Controls Office – Phase Gate Delivery Manual](#).

2.12 Construction Support

2.12.1 Introduction

[Reserved for future use]

2.12.2 Communications during Construction

In the Project Development and Project Design phases, except during the contract advertising period, the Bridge Designer may answer inquiries from outside ODOT about typical projects. On politically or environmentally sensitive projects refer questions, especially those from the press or public, to the State Bridge Engineer, or the TPM or RE-CP.

From the advertisement date until the project is awarded, the Resident Engineer has sole responsibility for answering questions about the project. This insures equitable treatment of prospective bidders and avoids conflicting information about plans, specifications, and bid items. Therefore, avoid conversations with prospective bidders during this period and refer them to the Resident Engineer listed in the front of the project special provisions.

2.12.3 Shop Drawing Review

[Reserved for future use]

2.12.4 Temporary Works Review

[Reserved for future use]

2.12.5 Construction Support Close-Out

2.12.5.1 As-Constructed Drawings

As-Constructs can come in different forms. The obvious one's are from STIP projects, but they can also come from Maintenance Projects (if changes happen in construction) or Permit/Utility reviews. For permit reviews, even if typical As-Constructs are not prepared, the person reviewing the permit/utility request needs to update the bridge plans for the affected bridge(s).

See *BCM 7.11.1* for guidance.

2.12.5.2 Final Calculation Book(s)

Update calculation books submitted at design close out when design changes occur during construction. Follow the process and standards in *BDM 2.10.7* for updates/changes to calculation books that are a result of construction. Incorporate the changes as an addenda or edit and update the table of contents and page numbers accordingly and resign, then resubmit book to ODOT.

Significant design changes involving substantial structural analysis may necessitate a new calculation book.

2.12.5.3 Final Reports & Records

For Local Agency projects, to ensure that the requirements of the *National Bridge Inspection Standards (NBIS)* are followed under *Title 23*, submit a pdf file of the following reports and records as part of the Construction Support Close Out documentation:

- Pile Records.
- Final Geotechnical Report with documentation of changes made during construction.
- Final Hydraulics Report with documentation of changes made during construction.

2.13 (Reserved)

2.14 Coordination with Other Project Team Members

2.14.1 General

The intent of *Section 2.14* is to provide **high-level** guidance on the information provided by other disciplines to help guide planning and scoping of bridge projects. Defer to relevant project team members when project specific information is in conflict with this section.

2.14.2 Project Management

From a project manager's viewpoint, the expectation of the bridge designer is to provide a high quality design per scope, on-time and on-budget. Keep your project manager informed of both positive and negative impacts to these items to avoid surprises.

Items to coordinate with your project manager:

- Scope / Scope creep.
- Schedule.
- Budget.
- Overall project Quality Plan, and Bridge Quality Plan.
- Local, and other non-environmental permits.
- Bridge deliverables.

2.14.2.1 Local & General Permits

Local and general permits may be required for a variety of subjects to complete the construction of bridge work. Some typical local and general permits that may need input from the Bridge Designer:

- Land Use.
- Access Permit.
- Conditional Use Permit (CUP).
- Riparian setbacks.
- Floodplain.
- Tree ordinances.
- Willamette Greenway (along Willamette River).
- Noise variance.
- Underground Storage Tank (UST).
- Canal, diking, and irrigation districts.
- US Coast Guard Permit (for navigable waters).

Discuss permit needs (as they relate to the bridge) with the TPM or RE-CP, and RE. Provide needed information on the requestor's schedule to the TPM or RE-CP, and RE to meet the permitting schedule for the project.

Regarding permitting, in the situation of an interstate river crossing into Washington or Idaho, ODOT may need to apply for permits required by the other state if ODOT is the contracting agency.

2.14.3 Survey and Mapping, & Right-of-Way

2.14.3.1 Survey and Mapping

Obtain survey and mapping data as early in project development as possible. Visit the project site with survey data and mapping in hand to get an “on the ground” feel for the lay of the land, and visually check the survey and mapping data for any discrepancies. Identify or confirm site constraints known at this time.

2.14.3.2 Right Of Way

Include any proposed and existing right-of-way limits and any construction easements with the vicinity map information. Ask yourself: Can the bridge and the contractor's operations (work bridge, shoring, falsework, future inspection and maintenance staging areas, the potential need for a detour structure, etc.) be accommodated within these limits, as well as safely ingressing and egressing to and from the highway system by agency personnel?

In order to ensure the bridge inspectors and bridge maintenance personnel have a safe place to park vehicles and stage maintenance operations behind the approach guardrail, the Bridge Designer works with the roadway designer to identify the appropriate space. If the bridge is located over another roadway, consider additional parking/staging space behind the undercrossing route railing. In order to provide a safe ingress and egress from the highway system, the Bridge Designer is encouraged to locate these areas behind the trailing end guardrail.

For the bridge project that has very minor roadwork, verify that steps to acquire necessary right-of-way have been initiated.

For questions about right-of-way data, contact the project's roadway designer, who is in touch with the Right-of-Way Section and Right-of-Way Services personnel.

2.14.4 Roadway

2.14.4.1 Project Geometry

Review the project geometry with the roadway designer to verify that you have the latest alignment, roadway cross-sections, and grades. Some questions to consider:

- Do grades, superelevations, etc., provide enough vertical clearances for the type of bridge anticipated?

- Is the choice of bridge width and horizontal and vertical alignment consistent with traffic volume and type of highway?
- Bridges that are more susceptible to roadway surface icing and have superelevation rates in excess of 0.08 ft/ft are considered hazardous under those conditions. Use greater rates only if special study has determined that the greater rate is desirable.

2.14.4.2 Roadway Clearances

Clearances required for highway overcrossings are shown in *Figures 2.14.4.2-1*, and *2.14.4.2-2*.

Note: Use 18 feet min. horizontal clearance for one lane (19 feet for interstate).

Figure 0-1 Roadway Clearances for Structures

The clear zone requirements shall be determined from the AASHTO publication "Roadside Design Guide".

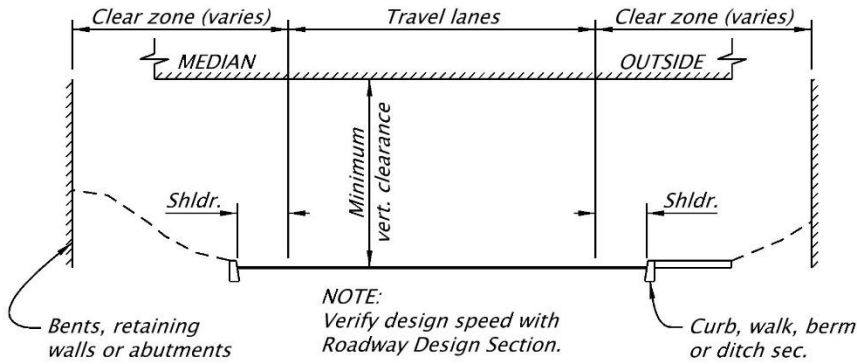

ROADWAY CLEARANCES FOR STRUCTURES

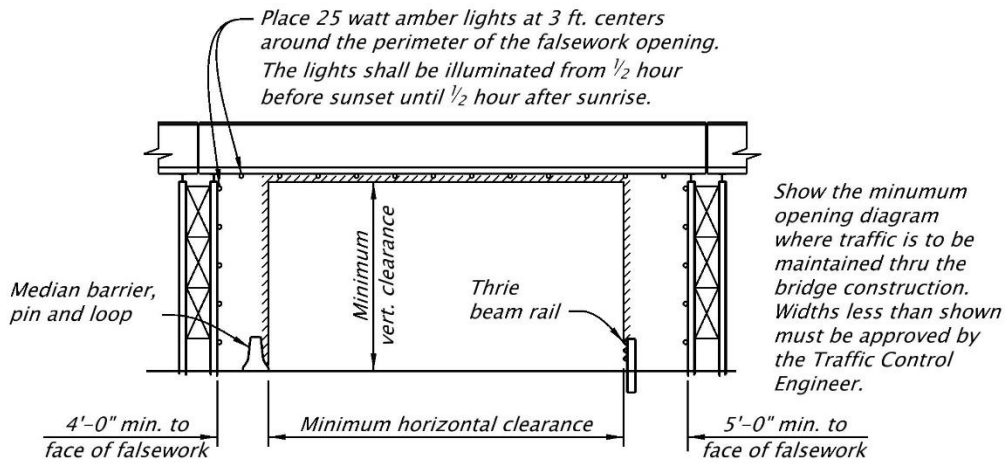

LIMITED CLEARANCE DURING CONSTRUCTION

Figure 0-2 Clearance Envelopes

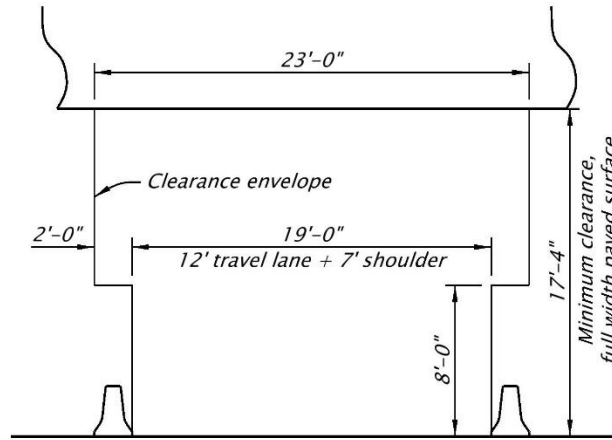

ODOT 4R PROJECT

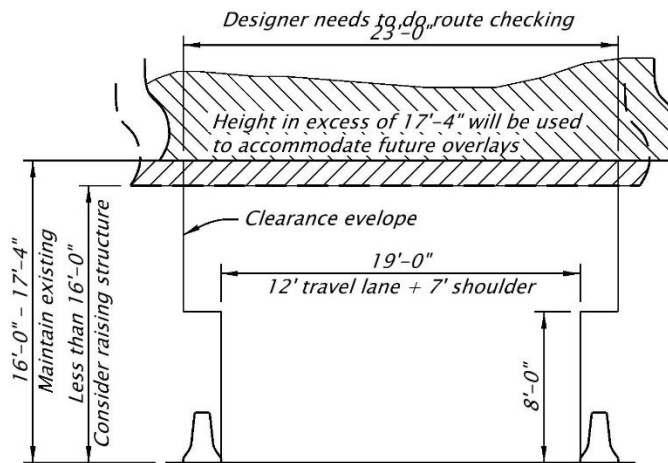

ODOT 3R PROJECT

CLEARANCE ENVELOPES FOR SINGLE LANE INTERSTATE

2.14.4.2.1 Roadway Widths

Coordinate the bridge width with the roadway designer at the beginning of the Project Development (ie, Pre-DAP Milestone) Phase. The bridge should fit within the context of the roadway.

On state highways, the *ODOT Highway Design Manual* shy distance requirements should be met when determining shoulder widths on bridges. Bridge rail requires shy distance unless separated from the roadway shoulder by a raised sidewalk. The bridge and approach roadway width will be the same where a roadside barrier is present on both the bridge and approach roadway. When the approach roadway does not include roadside barrier, the bridge roadway width will be wider than the approach roadway by the required shy distance.

For estimating purposes during desk scoping, assume the bridge roadway width will be four feet wider than the approach roadway, unless roadside barrier is present.

2.14.4.2.2 Sidewalk and Bikeway Widths

On State projects, the width of Sidewalks and Bikeways is determined according to the *ODOT Highway Design Manual* as modified by all relevant Technical Guidance. In urban areas, it may also vary based on local requirements and the *Blueprint for Urban Design*. Consult with the roadway designer for site specific requirements.

For estimating purposes during desk scoping, assume a sidewalk width of seven feet and a bikeway width of eight feet, where required.

2.14.4.2.3 Height of Curbs and Sidewalks

Comply with *AASHTO LRFD Bridge Design Specifications Section 13*.

2.14.4.2.4 Vertical Clearance

Vertical clearance policy is established by the Roadway Engineering Section and is listed in *Section 4.5* of the *ODOT Highway Design Manual*.

Review and comply with the *Oregon Vertical Clearance Standards Map and High Routes* (High Routes are highway segments that are the most important when high loads are moved) *Highways Table* during development of the Bridge TS&L (and DAP). Additionally, before finalizing the clearance of the bridge, consult with the pavement designer to determine if an additional allowance is required for future pavement preservation treatments. If a project consists of 3R preservation work and a decrease in the vertical clearance below the level of the minimum vertical clearance is proposed, ensure that the roadway designer has consulted with the Permit Program Coordinator for the Motor Carrier Transportation Division (MCTD), and a Design Exception Request has been submitted. The Permit Program Coordinator for MCTD will need to collaborate with industry and with the Mobility Steering Committee before providing a written response to the project development team. Follow the same process when proposing a reduction to the vertical clearance requirements for a new bridge. No reduction of the vertical clearance on existing bridges, or a reduction in the standard for a replacement bridge will be allowed without

written approval from the Motor Carrier Transportation Division (MCTD). Include a copy of the approved Design Exception for a non-standard vertical clearance in the calculation book.

All new bridges where no vertical clearance limitations currently exist require consultation with MCTD to ensure that ODOT understands the impact of the proposed decrease to the user.

VERTICAL CLEARANCE DESIGN STANDARDS:

Minimum Vertical Clearances are actual measured heights, representing the shortest allowable distance between the lowest point on the underside of a bridge and the surface of the pavement for the entire width of the roadway, including shoulder area. Minimum Vertical Clearances include a four inch buffer, but do not take into account additional height for any future pavement overlay thickness.

Table 2.14.4.2.4-1 Minimum Vertical Clearances

New Construction Projects	
Route Type	Height (feet)
High Routes	17.25
NHS (not on High Routes)	17
non-NHS (not on High Routes)	16
Other Projects	
No reduction in existing vertical height clearance below the Minimum Vertical Clearances.	
No reduction in vertical clearance if existing vertical height clearance is below the Minimum Vertical Clearance.	

LEGAL LOAD HEIGHT

The maximum height for legal loads is 14 feet.

2.14.4.2.5 Clearances during Construction

Horizontal and Vertical Design Policy for clearance during construction has been established by the Traffic-Roadway Engineering Section. Coordinate with the Traffic Control Plans Engineer for minimum clearances applicable on the project. If the clearances required cannot be maintained during construction consult with the Traffic Control Plans Engineer for concurrence and notify MCTD.

Table 2.14.4.2.5-1 Minimum Horizontal Clearances During Construction

No. Lanes	Clearance Height (feet)
Freeway Mainline (Not with a Crossover)	
One Lane	19 (16 if over-dimensional loads and annual permits are detoured)
Two Lanes	28 (28 if over-dimensional loads and annual permits are detoured)
Freeway Crossover	
One Lane	19 (16 if over-dimensional loads and annual permits are detoured)
Two Lanes	32 (28 if over-dimensional loads and annual permits are detoured)
Non-Freeway Roadways (Freight Route)	
One Lane	19 (14 if over-dimensional loads and annual permits are detoured)
Two Lanes	28 (28 if over-dimensional loads and annual permits are detoured)

VERTICAL CLEARANCE:

For locations with an existing clearance 17 feet or greater, provide 17 feet minimum vertical clearance. For locations with an existing clearance less than 17 feet, no reduction in clearance will be allowed during construction. Always notify the MCTD if reduction of the existing vertical clearance is planned for the construction season.

2.14.4.3 Bikeways

Oregon law requires that reasonable amounts of highway funds be spent for bicycle and pedestrian facilities. That means: consider bikeway staging needs wherever highways, roads, or streets are being constructed, reconstructed, or relocated.

Bikeway is a general term meaning any road or path open to bicycle travel regardless of whether it is designated for bicycles or to be shared with pedestrians or automobiles. Specific types of bikeways are:

- Bikes lanes or bike paths.
- Shared roadways.
- Shoulder bikeways.
- Sidewalk bikeways.

For more information on bikeways, refer to the *Oregon Bicycle Plan* and *AASHTO Guide for the Development of Bicycle Facilities*.

2.14.5 Traffic and Mobility

2.14.5.1 Traffic Handling and Data

Used here, traffic includes:

- Vehicles.
- Bicycles.
- Pedestrians.

There are four traditional methods of handling traffic when replacing a bridge:

- Close the highway while removing and rebuilding the bridge.
- Construct a temporary detour around existing bridge and replace the bridge on the existing alignment.
- Use the existing roadway and bridge while constructing a parallel bridge on new alignment.
- Use stage construction with one or more existing or new lanes carrying traffic while other portions of the existing bridge are being removed and rebuilt.

Often the last method is recommended over the second and third methods. However, without proper investigation stage construction may:

- Cause a high number of complaints from the traveling public.
- Mean greater danger for ODOT and contractor personnel as well as to the public.
- Result in construction difficulties and longer construction time.
- Adversely affect the quality of the finished product.

Consider if there are alternate and possibly more satisfactory solutions. Include Accelerated Bridge Construction (ABC) concepts when assessing options.

2.14.5.2 Moveable Bridge Traffic Control Equipment

Work closely with the traffic signal and sign designers to ensure design from each discipline is detailed or referenced appropriately. Refer to the [ODOT Traffic Signal Design Manual: Chapter 23](#) for moveable bridge traffic signal and sign design guidance. See *BDM 1.12.4.1, On-Bridge Sign & Illumination Mounts* for bridge mounted traffic structure guidance.

Detail the following items on the Bridge Plans Sheets:

- Control system that activates the traffic signals and flashing beacons (cabinets, power source, termination of wires, etc.).
- Location of Gate arms.
- Audible devices for warning traffic.
- Non-standard poles, foundations, or mounting for signal heads, signs, and flashing beacons.
- Electrical conduit routed on/through the bridge structure (including expansion fittings).

- Junction Boxes located on the bridge structure.

Detail the following items on the Signal Plan Sheets:

- Location of the traffic signals.
- Location of the STOP line.
- Use of and location of the flashing beacon warning devices.
- PTR signs (site specific for the I-5 NB and SB Columbia River Bridge only).
- Wiring from the traffic signals and flashing beacons to the control system (wire terminations are detailed on the bridge plans).
- Electrical conduit not routed on/through the bridge structure.
- Connection details for conduit going onto (or off) of the bridge structure (Junction box, expansion fitting, etc.).
- Standard poles, foundations, and mounting for signal heads, signs & flashing beacons.

Detail the following items on the Signing Plan Sheets:

- Ground mounted signs that do not have a flashing beacon.

2.14.6 Foundations and Geotechnical

See *BDM 1.10, Foundation Considerations* and the *GDM*.

2.14.7 Hydraulics and Scour

2.14.7.1 Hydraulics, General

The hydraulics designer will provide data and recommendations in support of bridge foundation and scour protection design.

2.14.7.2 Waterway Openings and Hydraulic Requirements for Stream Crossings

DESIGN DISCHARGES

The design discharge for bridges on Interstate Highways and highways with an Average Daily Traffic (ADT) greater than or equal to 750 is the 50-year flow. The design discharge for bridges along highways with an ADT of less than 750 is the 25-year flow. Bridges spanning over designated FEMA floodways are designed using the 100-year flow (base flood).

BRIDGE WATERWAY OPENING

The bridge waterway opening must be capable of conveying the design discharge with the appropriate clearance to the projected design high water elevation according to the following:

- Width of waterway opening is measured normal to stream flow. The waterway area is the normal channel area below the design discharge high water elevation. Minor channel

cleanup and modification is acceptable, but major lowering of the streambed under the bridge to increase the opening is not only ineffective but unacceptable.

- The Hydraulics Report will determine the high water elevation at the upstream face of bridge. The minimum bottom-of-beam clearance to the high water elevation is one foot or three feet when drift or debris is a concern (the hydraulic designer will review the bridge inspection reports and check-in with District Bridge Supervisor to confirm any ongoing debris issue, and then coordinate debris criteria with the project team when applicable). If practical, one foot of clearance above the 100-year flood elevation is provided. Also note that there is “no net rise” in water elevation allowed at bridges that will cross over a FEMA regulatory floodway.
- The exception would be for county and city bridges whose approaches are overtopped more frequently than once every 10 years. The minimum bottom-of-beam elevation provided for these situations is one foot above the 10-year design flood elevation.
- Under rare circumstances, such as a park settings or where other controls on grade lines make it necessary, high water above bottom of beam, or over the deck, may be allowed.
- Ordinarily, the design flood should not overtop the adjacent roadway. When the roadway overtopping flood is less than the design flood, the overtopping flood becomes the design flood.

If there are no future plans to raise a roadway to eliminate overtopping, a combination of bridge waterway opening and overtopping at the low points of adjacent roadway may be an acceptable alternate to accommodating the entire stream flow under the bridge. For Interstate Highways, the minimum overtopping frequency is 50 years.

Roadway overtopping at lesser recurrence intervals than the 50/25 years is acceptable and allowable in certain circumstances such as:

- Other roads in the area are overtopped.
- Traffic counts are low.
- Alternate routes are available.
- Road is useable when overtopped (shallow overtopping).
- The required bridge would be excessively long or high and a review is made of the effect of backwater and overflow on adjacent properties and facilities.

2.14.7.3 Bridge Scour Design

2.14.7.3.1 Scour Evaluation and Design

The scour analysis can be referenced in the project Hydraulics Report. The scour analysis shall include analysis on possible long term changes in the channel bottom elevation due to either aggradation or degradation, possible shifts in channel alignment, contraction scour and local pier scour. Abutment scour and the potential for **washout** conditions are also evaluated. Scour depths are calculated for both the 100-year (design/base flood) and 500-year (check flood) events. However, if the incipient roadway-overtopping flood can occur, it is usually the worst case for scour because it will usually create the worst scour conditions at the bridge site (greatest flow

contraction and highest stream velocity). Therefore, scour depths are calculated depending on the recurrence interval for the overtopping flood.

2.14.7.3.2 Scour at Bridge Abutments

The potential for scour at the bridge abutments must also be considered at all waterway crossings. Abutment scour, lateral stream migration (channel changes) or overtopping of the approach embankment could all result in partial or complete removal of approach fill material and severely destabilize the abutment foundation and the bridge. A **washout** condition could occur under any of these conditions where the approach embankment supporting the abutment foundation is completely scoured out. Evaluate each of these three conditions described below:

ABUTMENT SCOUR:

ODOT policy states that abutment scour calculations are not required if abutment and approach fill slopes in the waterway are protected with a properly designed revetment protection system, such as a riprap blanket with a toe trench extending down to the maximum scour elevation. Revetment methods are discussed in the *ODOT Hydraulics Manual, Chapter 10*, and in the *FHWA Highway Engineering Circular No. 18 (HEC-18)*. The revetment protection must be capable of withstanding the velocities and flow associated with the check flood event. With this level of protection, the scour prism is reduced to just the contraction scour, scour from degradation and local pier scour (if applicable) for use in scour design of the bridge.

For abutments and bridge fill slopes in contact with stream flow or wave action and not protected with permanent revetment measures, abutment scour is calculated (if hydraulic and site conditions are appropriate). Abutment scour could lead to destabilization of the bridge end slope and loss of embankment material supporting the bridge foundation and abutment. If this condition is possible, then consider the potential for a full washout condition for both the 100 and 500 year flood events.

ROADWAY OVERTOPPING:

Overtopping of the approach fill near the bridge end may also result in a washout condition (ref. *HEC-18* and *AASHTO 2.6.4.5*). Consider this condition in cases where the overtopping is located in the proximity of the bridge end and a breached embankment could result in the scour and removal of fill material supporting the bridge abutment foundation. Properly designed slope protection and revetment may provide sufficient mitigation against the potential for a washout condition depending upon site conditions. However, because each overtopping case is unique, carefully evaluate each for the potential of a **washout** condition. If a **washout** condition is considered feasible, the amount of embankment material that could be removed, and the scour depths, are to be determined by the hydraulic designer.

LATERAL STREAM MIGRATION:

Evaluate the potential for lateral streambed migration (channel changes) for possible detrimental effects leading to erosion or scour of the bridge approach fills. For unprotected, or even well protected, abutment slopes, if there is a possibility that the stream channel could shift toward the

abutment such that the revetment might not be relied upon for permanent protection, then assess the condition of a full or partial washout of the abutment fill material. The potential and likelihood for stream channel migration and the resulting affects, is determined by the hydraulic designer who also determines whether protective measures such as channel guides, stream bank stabilization techniques or other measures could be employed to mitigate this potential. The hydraulic design and any stream bank stabilization measures must demonstrate that the channel won't migrate toward the abutment such that it could cause a destabilization of the slope and a potential **washout** design condition.

Under a washout condition, refer to *BDM 1.10.5.3* for scour design requirements.

2.14.7.3.3 Scour Design

Refer to *BDM 1.10.5.3* for scour design requirements.

2.14.7.4 Hydraulics Documentation

The hydraulics designer will prepare and provide three design report deliverables for bridge projects as follows:

- Preliminary Bridge Hydraulics Recommendations.
- Draft and Final Hydraulics Report.

PRELIMINARY BRIDGE HYDRAULICS RECOMMENDATIONS

The bridge hydraulic recommendations is prepared and distributed to the project team after the kick-off meeting and before submitting the hydraulic survey request.

- Bridge, geotechnical, roadway, traffic, and hydraulic designers review scoping notes. The design details such as alignment (horizontal/vertical changes), site constraints, bridge layout and approach embankments, traffic control, and hydraulic concerns such as highly erodible floodplains or channel lateral migration that could washout embankments are discussed and coordinated between team members.
- Bridge designer outlines bridge/structure type, and geometry such as bent locations, width, and wingwalls.
- The hydraulic designer will prepare a preliminary bridge hydraulics recommendation which is distributed to the project team and is based on coordination between the project's bridge, geotechnical, and hydraulic designers. The recommendation includes a preliminary idea of the hydraulic structure type, size, location, and special features or concerns. An example of this report is provided at the following link: [Hydraulics Recommendation Example](#).

HYDRAULICS REPORT

The hydraulic modeling and analysis begins after obtaining the hydraulic survey data. It is good practice for the roadway, bridge, geotech, and hydraulic team members to check-in with each

other at this point (just prior to the start of the hydraulic model task) so any changes are reflected in the model.

The Hydraulics Report provides detailed information that supports structure and roadway design. The report includes hydrologic calculations, 1D/2D bridge hydraulics modeling results for permanent and temporary bridges, scour analysis, revetment design, floodplain impact analysis, and the temporary water management summary and concept plan sheet.

The hydraulic designer will prepare the draft Hydraulics Report during the DAP phase, which is provided with the DAP submittal package. The hydraulic and bridge designer will need to review the project delivery schedule and make sure that the draft Hydraulics Report is complete and available for use to develop the TSL and bridge DAP deliverables. The final Hydraulics Report is provided with the Advanced submittal package.

A general outline of the modeling and distribution of hydraulic data during the DAP phase of a project is provided below:

- Hydraulic designer prepares model.
- Model results are summarized in a **hydraulics data sheet**.
- Scour analysis performed.
- Revetment sizing performed.
- The results of the model are shared with the bridge designer as soon as the details are added to the hydraulics data sheet.

All Hydraulic Reports will have a hydraulic data sheet for the proposed structure, see *Figure 2.14.7.4-1*. The data sheet includes the following information:

- Discharge and recurrence intervals for the design event, base flood and the 500-year or roadway overtopping flood.
- Backwater conditions with the new structure in place.
- Headwater and downstream water surface elevations at the bridge.
- The average water flow velocity at the bridge.

The information in the hydraulics data sheet is used to perform the scour and revetment analysis.

The hydraulics data sheet, and scour/revetment results are shared with the design team members at this point to perform the following design tasks:

BRIDGE DESIGNER:

- Verify the bottom-of-beam elevation is 1 or 3 feet higher than the design event **high-water elevation at upstream face of bridge**.
- Add the extent of abutment riprap on bridge plans **plan and elevation view** and note “see roadway plans for riprap details”. Revetment design recommendations will be detailed in the report sub-section for revetment. The roadway plans will include the riprap detail with the following information (1) riprap thickness (2) filter blanket thickness when applicable, (3) class of riprap, and (4) toe trench configuration and dimensions. An

example of the riprap detail to be included on the roadway plans is illustrated in *Figure 2.14.7.4-2*.

- Verify the end and interior bent supports (piles, shafts, footings) are below the scour elevation stated on hydraulic data sheet or in the report sub-section for scour. The design summary will note when footings are to be anchored into rock as coordinated between bridge engineer and geotechnical engineer.
- Add the **hydraulics data table** to the bridge plans, see *Figure 2.14.7.4-3*.

Figure 2.14.7.4-1 – Sample Hydraulic Data Sheet

BRIDGE

PROJECT: Oak Creek Bridge # 18463
Pacific Hwy - Lebanon (RR Tracks) Section
Corvallis - Lebanon Highway, M.P. 12.48
Linn County Key # 06420

COMPILED BY: _____
DATE: 6 October 1997

TABLE 2: Proposed Bridge	HYDRAULIC DATA			
	DESIGN EVENT	BASE FLOOD	ROADWAY OVERTOPPING FLOOD	ORDINARY HIGH WATER
Discharge (cfs)	1,850	2,390 ⁶	2,060 ⁵	-
Recurrence Interval (yrs)	50	100	80	
Approach Section H.W. Elevation w/Natural Channel ¹ (ft)	277.0	277.5	277.2	-
Approach Section H.W. Elevation w/ Bridge ¹ (ft)	277.8	278.4	278.0	274.7
Backwater (ft)	0.8	0.9	0.8	-
H.W. Elev. at Upstream Face of Bridge ² (ft)	277.7	278.3	277.9	274.6
H.W. Elev. At Downstream Face of Bridge ³ (ft)	276.5	276.9	276.7	274.4
Waterway Area at Downstream Face of Bridge ⁴ (ft ²)	290 (331)	290 (331)	290 (331)	--
Average Velocity at Downstream Face of Bridge (ft/s)	6.4	7.0	6.4	-

¹ Approach section is one waterway opening width upstream from upstream face of bridge.
² Located at upstream face of bridge along the embankment.
³ Located at downstream face of bridge opening.
⁴ Area normal to channel centerline. Area in parentheses is parallel to roadway centerline.
⁵ 1,870 cfs flows under the bridge and 190 cfs flows through culverts west of the bridge.
⁶ 2,030 cfs flows under bridge, 170 cfs flows over road to west of bridge, and 190 cfs flows through culverts to the west of the bridge.

REMARKS:

The spillthrough structure is a 70-foot long single-span bridge with combination spillthrough/vertical abutments. The structure is skewed 29 degrees. Three 36-inch diameter culverts are located under the roadway to the west of the bridge.

Manning's "n" bridge opening = 0.04
Manning's "n" main channel = 0.04
Manning's "n" overbanks = 0.04

Figure 2.14.7.4-2 – Riprap Blanket and Toe Trench Detail

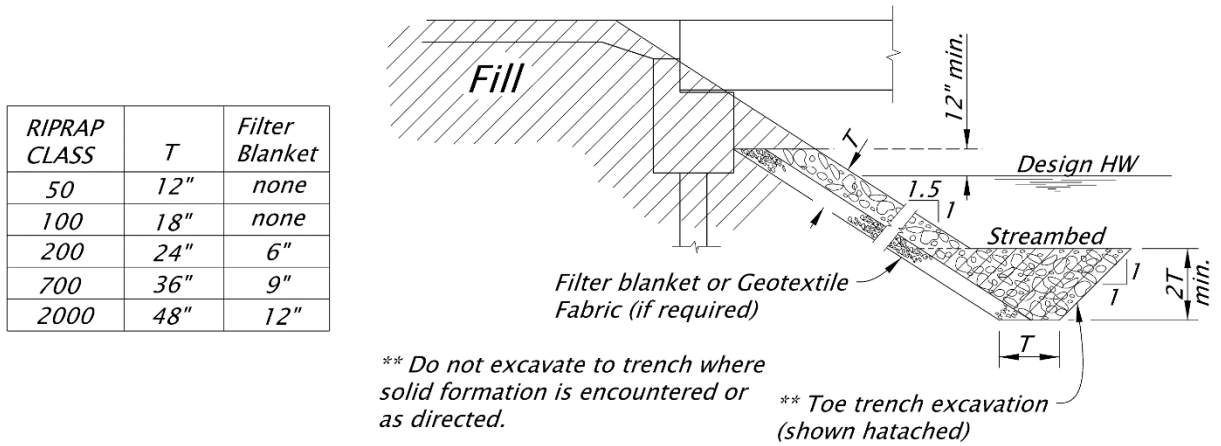

RIPRAP BLANKET AND TOE TRENCH DETAIL

Figure 2.14.7.4-3 Hydraulic Data Example Table

HYDRAULIC DATA				
ITEMS	UNITS	DESIGN FLOOD	BASE FLOOD	500-YEAR OR ROADWAY OVERTOPPING FLOOD
DISCHARGE	<i>cfs</i>			
RECURRANCE INTERVAL	<i>yrs.</i>			
HEADWATER ELEVATION AT UPSTREAM FACE OF BRIDGE ALONG EMBANKMENT	<i>ft.</i>			
BACKWATER	<i>ft.</i>			
SCOUR ELEVATION ¹	<i>ft.</i>			

¹ Scour elevation is provided in hydraulic report section titled "scour"

2.14.8 Environmental

Avoid, Minimize, Mitigate...

2.14.8.1 Environmental Performance Standards & Permits

See [PDLT Operational Notice PD-04](#) and the technical guidance document under References at the end of the Notice.

Environmental Performance Standards are considered during Project Scoping and Value Engineering in order to streamline the design process. This avoids unforeseen design requirements that may result in multiple project changes unanticipated project costs from regulatory requirements and to ensure enhancement options are considered and, where appropriate, included in the project budget.

Environmental Performance Standards determined to be applicable during Scoping are reevaluated at Project Initiation. During the Project Kickoff Meeting, identify design constraints and required permits.

National Environmental Policy Act (NEPA) requires that any activity or project receiving federal funding or other federal approvals undergo an analysis of potential impacts to the environment.

Some environmental rules, regulations, permits and other topics that may be applicable on projects with bridges that may need discussion with the Environmental Specialist, or input from the Bridge Designer.

2.14.8.1.1 Permitting Elements

AQUATIC / HYDRAULICS

- In-Water Work Windows (Permissible time to work below the Ordinary High Water Elevation and or wetted channel).
- Span width.
- Fish bearing waterways will require spans free of bridge elements including scour countermeasures ranging from 1.0-2.2 times the average ordinary high water elevation width.
- Temporary structures. Consider the position, number, and spans of temporary piles during construction to facilitate:
 - Fish passage.
 - Normative flood-frequency elevations.
 - Watercraft (emergency, commercial, recreational).
 - Downstream free passage of debris (especially large wood) that may threaten the safety of the structure, cause localized or accumulate large debris.
- Vacant bridge elements. Remove past elements not required to maintain safety or bridge integrity, excluding those not considered historic or cultural resources.
- Rip-rap bent protection (Exclusion can affect type, size and location of the bridge's foundations.).

- Fluvial. Span width of waterway to allow for natural stream processes such as sediment and large wood movement, floodplain connectivity, normative scour, and normative vertical and lateral channel movement. Affects the length of the bridge, pier location, foundation depth, and abutment locations.).
- Foundation depth and type.
- Skew and bent placement that avoids impacts to fluvial processes and hydraulics that affect ROW, upstream and downstream properties, and recreational access and use.
- Hazardous Materials. Avoidance, disturbance, Removal, and disposal of on-site contaminated materials (soils, existing structures, and construction materials). E.g. pesticidal treated woods, lead paint, contaminated soils, blasting slag, and old construction materials containing asbestos.)
- Lateral and longitudinal connection of the floodplain.
- Temporary water management.

WETLAND

- Avoid wetland and waterway fill.
- Maintain and re-establish wetland connectivity.
- Avoid impacts to wetland hydrology.
- Avoid shading wetlands and or orient crossing to reduce daily periods of shading.
- Hazardous Materials. Repeat previous bullet.

CULTURAL

- Visual effects (looking away from the bridge, or looking at the bridge from afar) based on feedback from stakeholders (NSA, local agency requests, etc.).
- Archaeological, Historic and Cultural Resources. Identify areas and elements to avoid and preserve.
- Wetland disturbances.
- Riparian and floodplain vegetation impacts.
- Disturbance footprint as it relates the surrounding environment and terrain as it relates to cultural resources.
- Noise impacts associated with demo and construction related to fish, marine mammals, and the human environment.

OTHER CONSIDERATIONS

- Wildlife passage accommodations that may include the consideration of horizontal or vertical clearances, and embankment grade-breaks for wildlife passage.).
- Access, staging and disposal Areas (Estimate/Identify adequate areas for the contractor to stage work in so it can be environmentally cleared for use.).
- Stormwater conveyance for new and modified bridges.
- Does a current bridge provide native bird and bat habitat for any life-stage. Demolition may result in **take** which is regulated.

Discuss permit needs (as they relate to the bridge) and regulatory design and delivery guidance criteria with the Environmental representative on the Project Development Team. Provide needed information on the requestor's schedule to submit complete environmental clearance and meet the permitting schedule for the project.

Even if no permit is required, assume that plan sheets and special provisions will include Agency and Stakeholder derived:

- Restrictions.
- Specific Design and BMP elements.
- Technical details.

These elements reflect interagency collaboration and agreements intended to ensure that construction and the final design comply with various environmental regulations.

2.14.8.1.2 Permit Information Memo

The need to supply the required permit information as soon and as accurately as possible cannot be overemphasized. Some applications take six or more months to get approval.

It is not recommended to include all the necessary information for all the various permits in the Bridge TS&L Report. It can become unwieldy, and takes away from the purpose of the Bridge TS&L Report. Instead, it is recommended to coordinate with Environmental Section to convey information for use in preparing and applying for the various permits that are needed to complete the project.

Bridge TS&L Plan & Elevation drawings and vicinity maps may also be used as a basis for special permit drawings; but strip them of any information not needed to obtain the permit or relevant to environmental specs or design criteria. Keep in mind: the people reviewing the applications are not structural designers. They do not have time to sift through many drawing details and dimensions not relevant to the permit approval.

Topics that may require the Bridge Designer's input include:

- Project timing and chronology.
- Alignment and size of the new bridge in relation to the existing bridge (i.e., number of spans, length).
- Quantity of impervious existing bridge surface removed and added by the new bridge.
- Type of the new deck surface and construction methods.
- Type of the new bridge railing and construction methods.
- Proposed treatment of the runoff (i.e., number of scuppers or direct discharge drains on the old bridge vs. number of drains on the new bridge).
- Type, number and sizes of the existing bents/footings to be removed within the OHWM and the wetted channel or highest measured tide. Discuss the removal methods of the existing bents, footings and piles.

- Type, number and sizes of bents/footings added for the new bridge, within the OHWM and the wetted channel. Discuss the construction methods for the new footing, bents and piles.
- Type of isolation method used during construction (i.e., cofferdam).
- Development of proposed containment system(s) to prevent debris and materials from falling into environmentally sensitive areas below the bridge.
- For bridges with contaminated paints, discuss the method of removal and disposal.
- If a detour bridge, working bridge, or falsework are required, discuss how many bents and types of temporary supports that may be within the OHWM and wetted channel. Discuss the construction and removal methods that might be used.
- Extent and duration of in-water work (i.e., heavy machinery in wetted channel).
- Size, number, type, extent, and duration of pile-driving.
- Amount, extent, slope, depth of fill or rip-rap.
- Possible staging areas and access.
- Amount and type of vegetation to be removed (outside and within the OHWM).
- Amount of wetland impacted.
- Any planned mitigation.
- Lateral and longitudinal floodplain connection.
- Span, height, skew as related to a regulated channel. The regulated channel may be wider or narrower than existing conditions found at the crossing, and may be assessed by evaluating the entire river reach.
- Contraction scour.
- Shielded lighting that avoids waterways.

2.14.8.2 Protection of Recreational/Cultural Resources

Be alert to the effects of construction on:

- Recreational activities, areas, or facilities.
- Cultural resources such as fossils, artifacts, burial grounds, or historical bridges and dwellings.

Refer to *SP 00290, Environmental Protection*, specifically *SP 00290.50, Protection of Cultural Resources*.

Although normally researched and proposed by ODOT's Environmental Section, protection or consideration of these activities or resources can be initially overlooked. Permit requirements from agencies like the U.S. Army Corps of Engineers or Oregon Department of Fish and Wildlife deal with historical, cultural, and recreational concerns too. Here are some examples of challenges from the past:

- Protection of summertime river rafters passing under a contractor's work bridge.
- Removal of large amounts of river debris hung up on cofferdams endangering a collegiate racing crew practicing downstream.
- Saving of old or rare trees near a city bridge construction site in deference to neighborhood sentiment.

2.14.8.3 Bird and Bat Habitat

As there are no regulatory requirements (state or federal) for establishing bird or bat habitat on bridges, use discretion when providing the habitat. Do not intentionally design habitat if it compromises the structural integrity of the bridge, interferes with maintenance and inspection activities, or creates a public hazard. Consider off-bridge habitat when applicable.

Consult Environmental Section for previously developed details for the design of bat habitats. Only include bat habitat details when requested by Region environmental staff. The bridge types utilizing common details are side-by-side precast slabs, side-by-side precast box beams, precast Bulb-T bridges and precast Bulb-I bridges. The type of habitats included in the details are longitudinal slotted habitat in the slab and box beam bridges, transverse slotted habitat in the precast Bulb-T and Bulb-I bridges, and **cave habitat** in precast Bulb-T and Bulb-I bridges.

The selection of cave or slotted bat habitat depends on the species of bats that occupy the area. This can be determined by the Environmental Section.

The slotted habitats are typically $\frac{3}{4}$ inch thick and have varying depths depending on the bridge superstructure elements. For precast slabs and box beams, the slots are formed with $\frac{3}{8}$ inch recesses in each of the two adjoining members. The use of a $\frac{3}{4}$ inch recess in one member only was considered but rejected because of the risk of corrosion. A roughened recess surface is provided by sand blasting or forming.

Slotted habitats used in precast Bulb-T and Bulb-I girders are formed using $\frac{3}{4}$ inch thick precast greystone panels with roughened surfaces. Three panels are used with a clear spacing of $\frac{3}{4}$ inch between each panel. They are placed transversely to the beams and in contact with the bottom of the top beam flanges and the bottom of the deck. This is done to provide thermodynamic contact with the upper concrete. Access slots are provided at the bottom of the panels.

The cave habitats are also detailed for precast Bulb-T and Bulb-I girders. They are formed using precast or cast-in-place vertical walls and precast floor panels. The decision between precast or cast-in-place wall panels can be made by the designer, or left to the contractor. The complexity of fitting up the precast wall panels between the two precast girders may control this decision. In either case, the wall panels will be held in place by steel angles anchored in the precast beams. Provide access holes for the bats in both the floor panels and the end wall panels.

The location and number of habitat elements will be project specific depending on the population of bats in the area.

Locate habitat features using the following guidelines:

- Do not place bat habitat directly over a roadway or walkway. Bat guano can be a hazard to bridge inspectors, maintenance staff and the general public. If bat guano is allowed to accumulate and dry on a roadway or walkway, vehicle or pedestrian traffic will cause the guano to become airborne resulting in an increased health hazard.
- For vertical slot bat habitat, such as used with precast slabs and boxes, place slots at least 12 feet away from abutments and interior bents. This requirement provides a guano-free

zone for bridge inspection access to bearing locations. In addition, do not place slots within five feet of midspan.

- For cave-type habitat, often used with precast girders, do not place habitat within 15 feet of the abutments and interior bents. This requirement provides a guano-free zone for inspection of both bearings and the maximum shear portion of girders. In addition, do not place habitat within 10 feet of midspan.
- For abutment roughening that provides area for roosting, limit roughening to no more than 25 percent of the horizontal abutment face. It is preferable to keep roosting areas limited to the corners (closest to the exterior edges of the abutment).
- Bird roosting and nesting aversion. Intended to avoid the take of regulated species during construction and maintenance, facilitate long-term maintenance by avoiding the accumulation of guano, and reduce predation upon fish.
- Avoid the creation of ledges and flat horizontal surfaces that facilitate nesting by sea-birds and non-native nuisance species (e.g. rock-doves aka pigeons and European starlings)
- Angled tops or fitted cones should be considered for temporary and permanent piles in or near waterways to prevent sea-bird nesting for permanent and temporary piling in or near waterways. Platforms may be considered for raptors.
- Bridge Lighting (excluding safety): Consider using shielded fixtures less than 3000K that do not shine into the sky or attract birds into traffic.

Where proposed habitat details do not meet these guidelines, submit a design deviation.

2.14.9 Storm Water

Bridge modifications should consider routing pass through conveyance landward / possible treatment, and new and replaced bridges will convey stormwater to facilitate treatment. Engage Hydraulic Section when there is stormwater needs.

2.14.10 Utilities – Roles and Responsibilities

DISTRICT ROLES AND RESPONSIBILITIES

The Districts are the main point of contact for the location of all utilities and will issue all utility permits. (Utility permits are issued by ODOT to the utility companies.) Utility permits allow the installation, relocation, and removal of utilities within the State right-of-way. Utility companies will only be given a permit for the specific area they actually need for that installation. Space for future lines will need to be included on a separate permit application. If the utility installation requires holes to be drilled into the bridge, if the utility will add a significant amount of additional dead load on the bridge, or if the installation has the potential to be in conflict with any of the items in *BDM 2.14.10* and *BDM 1.12.6*, the District will refer the permit application to the Regional Bridge Lead Engineer and the Bridge Designer for their input and approval. Otherwise, the District Manager will simply approve, monitor the installation of the utility, and assure that all utility installations are labeled in accordance with accepted practices (see *BDM 1.12.6*).

REGION TECH CENTER ROLES AND RESPONSIBILITIES

When the District forwards a copy of a utility permit request to the Region Tech Center for review prior to the issuance of the permit, the Regional Bridge Lead Engineer and Bridge Designer will assure that the utility installation is in compliance with the items in *BDM 2.14.10* and *BDM 1.12.6*. Consult the Regional Bridge Lead Engineer when there are discrepancies. After review, return the permit application comments or approval to the District, who will monitor the utility installation.

For proposed utilities on historic bridges, have the application reviewed by the Region Cultural Resource Specialist.

BRIDGE ENGINEERING SECTION ROLES AND RESPONSIBILITIES

The Bridge Engineering Section (Preservation, Operations/Inspection, or Load Rating, as applicable) will provide input if the utility installation will have a direct impact on any of the following:

- The installation is on a bridge that has a cathodic protection system in place, or is within a Marine/Coastal Environment as defined in *BDM 1.2.4*.
- Installation has the potential to create a corrosive environment due to dissimilar materials.
- The utility is going to be installed on a drawbridge.
- The installation is in a confined space where its location or operation creates an unsafe environment for bridge inspection or bridge maintenance personnel.
- The installation calls for the installation of a High-Voltage Line on a bridge (See *BDM 1.12.6.1*).
- The utility contains a high-pressure line or volatile gases.
- The installation has the potential for adding a significant amount of dead load to the bridge or individual structural components (See *BDM 1.12.6*).

2.14.11 Railroad

Coordinate all site visits in which you will be on railroad right-of-way, or off railroad right-of-way but within 50 feet of the railroad track, with your Transportation Project Manager or Resident Engineer and the Utility & Railroad Coordinator. It is illegal to enter upon railroad right of way without proper permissions, PPE, and training.

2.14.11.1 Permits

If the bridge is over a railroad track, the Bridge Designer will be involved with providing information for the railroad permit applications.

Much of the information supplied for railroad permit applications by the Bridge Designer is in the form of drawings with specific data shown. Bridge TS&L Plan-and-Elevation drawings and vicinity maps are normally used as a basis for special permit drawings, but strip them of any information not needed to obtain the permit. Keep in mind: the people reviewing the applications

are not structural designers. They do not have time to sift through many drawing details and dimensions not relevant to the permit approval.

2.14.11.2 Railroad Considerations

When scoping bridge repair work above or adjacent to the Union Pacific Railroad right-of-way, consider the following items that may be required:

- A plan review by UPRR’s engineering personnel in Omaha, Nebraska. Expect a thirty working day turnaround.
- Crash wall addition. This would add approximately \$250,000 for each wall.
- Drainage review.
- Protective fencing.
- UPRR will want reimbursement for their involvement in the preliminary review work.

UPRR standards require crash walls if a pier, foundation or abutment is within 25 feet of an existing or future track centerline. Protective fencing is required on all bridges. ODOT maintains its own drainage. UPRR acknowledges existing construction and maintenance agreements, and will consider this for each review. Minor repair work will not warrant the safety upgrades to the bridge. Consult the ODOT Utility & Railroad Coordinator early in the process for any bridge work that could trigger these requirements.

2.14.11.3 Railroad Clearances

Show project specific design clearances, construction clearances, and shoring clearances on the contract plans. Refer to *DET1200* which contains many of the required railroad crossing details.

Design Clearances – Clearances required for permanent construction over railroads are shown in the design guides provided by the railroads or on the railroad’s website. See *BCM 7.3.8* and *Figure 7.3.8A*.

Shoring Clearances – Shoring clearances required for construction adjacent to railroads are shown in the design guides provided by the railroads or on the railroad’s website.

A shoring diagram showing the proposed excavation relative to the tracks and all other pertinent information as detailed in the design guides.

Construction Clearances – Construction clearances required for construction over railroads are shown in the design guides provided by the railroads or on the railroad’s website.

Show a construction clearance diagram similar to *Figure 2.14.11.3-1* on the plans.

Figure 2.14.11.3-1 – Railroad Construction Clearances

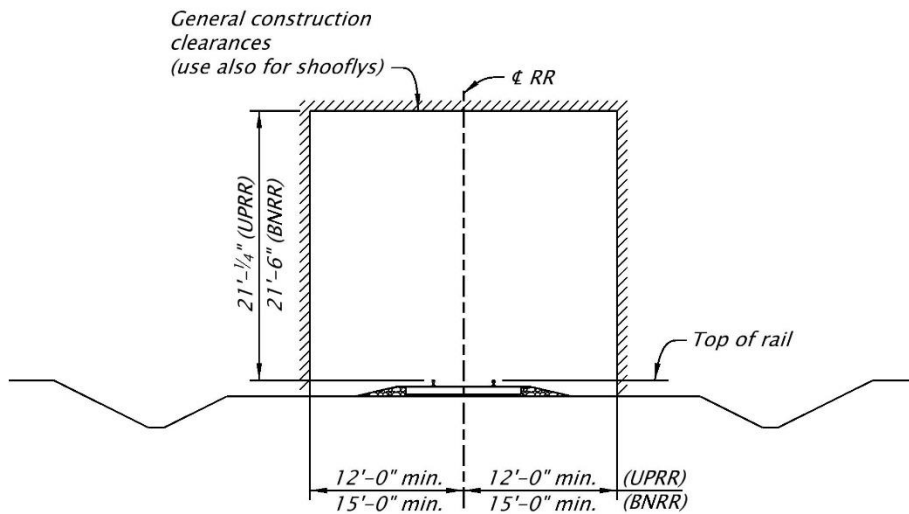

NOTE:
On curved track, add 1½" clearance per degree of curve.

Note: All horizontal clearances shown are for tangent track. On curved track, increase the lateral clearances per AREMA Specifications. For special cases, such as in yards, lesser clearances may be agreed to by the railroad.

2.14.12 Public Involvement

See [PDLT Operational Notice PD-12](#).

[Reserved for future use. (Talk about possible need to prepare exhibits and provide info to the Transportation Project Manager, Resident Engineer, State Bridge Design Engineer, or PI staff for public presentations.)

Appendix – Section 2.5 – Quality (In-House Design)

The following forms are posted on the [ODOT Bridge website](#):

[Bridge Designer QC Form](#)

[Bridge Reviewer QC/QA Checklist](#)

[Bridge Checker QC Form](#)

[Bridge Preservation QC/QA Form](#)

[Bridge Audit QC Report](#)

[Bridge EDMS QC Checklist](#)

[Bridge Drafter QC Checklist for Bridge TS&L Plan Sheet\(s\)](#)

[Bridge Drafter QC Checklist for Advance Plans Plan Sheet\(s\)](#)

[Bridge Drafter QC Checklist for Bridge TS&L Plan Sheet\(s\)](#)

See *BCM*.

[Bridge Drafter QC Checklist for Advance Plans \(95%\) Plan Sheets](#)

See *BC/M*.