



**OREGON
DEPARTMENT OF
AGRICULTURE**

**FOOD SAFETY PROGRAM
High Temperature Short Time (HTST)
Pasteurizer Operator
Study Manual**

2022 Version

Table of Contents

I. ACKNOWLEDGMENTS.....	3
II. PURPOSE.....	3
III. ABBREVIATIONS.....	3
IV. DEFINITIONS.....	4
V. RULES AND REGULATIONS.....	8
VI. LICENSE AND FEES.....	8
VII. INTRODUCTION.....	9
VIII. GRADE “A” RAW MILK STANDARDS.....	9
IX. HTST PASTEURIZATION.....	10
X. BASIC HTST DESIGN AND FLOW PRINCIPLES.....	12
XI. HTST EQUIPMENT AND FUNCTION.....	14
XII. CLEANING AND SANITIZING.....	24
XIII. TESTING OF PASTEURIZATION EQUIPMENT & FREQUENCY.....	26
XIV. BROKEN SEAL NOTICES.....	28
XV. BASIC HTST FLOW WITH SANITARY SEAL LOCATIONS.....	30
XVI. COMMON HTST PASTEURIZER COMPONENTS.....	33

ADDITIONAL RESOURCES:

PMO SECTION 16P. PASTEURIZATION, ASEPTIC PROCESSING AND PACKAGING, AND
RETORT PROCESSED AFTER PACKAGING (Pg. 90)

PMO APPENDIX I. PASTEURIZATION EQUIPMENT AND CONTROLS – TESTS (Pg. 284)

I. ACKNOWLEDGMENTS

The development, preparation, and publication of this manual was done with supplemental information and images from:

- Wisconsin Division of Food Safety in Partnership with Wisconsin Association for Food Protection: Pasteurizer Operator Certification Training
- Department of Health and Human Services, Public Health Service/Food and Drug Administration, Division of Human Resource Development State Training: Milk Branch Pasteurization Controls and Tests Course# 302.
- Washington Department of Agriculture Pasteurizer Operator Study Guide. PUB 425-308 (N/6/2010)

II. PURPOSE

The purpose of this manual is for the operator to review and understand the basic design, function and operation of High Temperature Short Time (HTST) and High Heat Short Time (HHST) pasteurization systems and to understand the principles and many public health reasons for the pasteurization of milk.

III. ABBREVIATIONS

3-A SSI (3-A Sanitary Standards, Inc.)	MBTS:	Meter Based Timing System
°C (Degrees Celsius)	OAR:	Oregon Administrative Rules
°F (Degrees Fahrenheit)	ODA:	Oregon Department of Agriculture
+ (Positive)	ORS:	Oregon Revised Statutes
- (Negative)	PI:	Pressure Indicator
+/- (Plus or Minus)	PPR:	Product to Product Regenerator
BP:	PPS:	Pasteurized Pressure Sensor
BPV:	PMO:	Pasteurized Milk Ordinance
CFR:	PT:	Pressure Transmitter
CIP:	RT:	Recording thermometer
CLT:	RTD:	Resistance Temp. Thermometer
DRT:	RO:	Reverse Osmosis
FDD:	RPS:	Raw Pressure Sensor
FDV:	SG:	Sight Glass
FSP:	SFLR:	Safety Flow Limit Recorder
HHST:	STLR:	Safety Thermal Limit Recorder
HT:	TP:	Timing Pump
HTST:	UHT:	Ultra-High Temperature
IT:	UP:	Ultra-Pasteurization
LDV:	VC:	Vacuum Chamber
MF:	VB:	Vacuum Breaker
	VFD:	Variable Frequency Drive

IV. DEFINITIONS

The following definitions are from the Oregon Revised Statutes (ORS) Chapter 621, the Oregon Administrative Rules (OAR) Division 24, and the Pasteurized Milk Ordinance (PMO).

Acid: a substance that, when added to water, increases the concentration of H⁺ (hydrogen) ions in the water.

Atmospheric Pressure: The force exerted on an area by the column of air above that area. Atmospheric pressure at sea level is 14.7 pounds per square inch.

Alkalinity: refers to the capability of water to neutralize acid.

Aseptic Processing and Packaging: Milk and/or milk product has been subjected to sufficient heat processing and packaged in a hermetically sealed container, to conform to the applicable requirements of 21 CFR Parts 108, 113 and 117 and to maintain the commercial sterility of the milk and/or milk product under normal non-refrigerated conditions.

Balance Tank: Raw product tank located at the start of a pasteurization system used to maintain a constant supply of product to the pasteurizer.

Booster Pump: A centrifugal pump placed in a pasteurizing system between the balance tank and the raw regenerator and capable of producing positive pressure in the raw regenerator.

Centrifugal Pump: A high speed pump that produces product flow due to the velocity increase of the liquid caused by the rotation of the pump impeller.

Cooling Section: The section of a heat exchanger (press) in which one of several non-toxic coolants flows in a counter current direction on the opposite side of a stainless-steel plate of the pasteurized product.

Condemned Container: Container deemed by Department as unfit for use because of dirt, rust, open seams, or other conditions that would or may contaminate fluid milk, milk or dairy products, or would otherwise render them unfit for consumption by humans.

Container: Milk and cream cans, farm milk tanks, milk tank trucks, milk storage tanks, pasteurizing vats, cheese vats, butter churns, butter tubs, cheese hoops and any other receptacle designed for use or used to hold fluid milk, milk or dairy products.

Cream: Portion of milk consisting of milk fat.

Dairy Operator: Person licensed by the Department to conduct one or more of the following activities related to the operation of a milk distributor or dairy products plant. A separate license is required for each of these activities conducted by an individual:

- (a) **Sampler-Grader:** Person responsible for the grading of milk received by a milk distributor or dairy products plant, and collecting regulatory samples of raw for pasteurization milk being received.
- (b) **HTST Pasteurizer Operator:** Person responsible for the legal pasteurization of milk and/or dairy products utilizing "high temperature short time" (HTST) pasteurization equipment. This includes HHST and UHT pasteurization equipment.
- (c) **Vat Pasteurizer Operator:** Person responsible for the legal pasteurization of milk and/or dairy products utilizing vat or batch pasteurization equipment.

Dairy products:

- (a) Butter
- (b) All varieties of cheese, frozen desserts and frozen dessert mixes containing milk, cream or nonfat milk solids
- (c) Evaporated, condensed, concentrated, powdered, dried or fermented milk, whey, cream and skimmed milk

Dairy products plant:

- (a) An establishment where milk is received, processed or used in manufacturing dairy products for human consumption
- (b) A place or premises where milk is received or collected
- (c) A bulk tank truck or other mobile equipment used by a milk hauler or other person in the transportation of milk, fluid milk or milk products
- (d) A location operated by a non-processing cooperative, corporation, association or person serving as a marketing agent for producers

Deflector Plate: A stainless steel plate in the regenerator section of the press designed to change the direction of flow.

Flow Diversion Device: Either a single stem (one three-way valve) or dual stem device (two, three-way valves connected by a common yoke), designed to change the direction of product flow and prevent the forward flow of raw milk. It is controlled by the recorder-controller.

Fluid milk: Milk and any other product made by the addition of a substance to milk or to a liquid form of milk product if the milk or other product is produced, processed, distributed, sold or offered or exposed for sale for human consumption. Fluid milk includes sterilized fluid milk products and the fluid milk products for which a standard of identity has been established by the department.

Frequency Pen: A solenoid actuated recording pen (located on the outer edge of the recording chart) that records the position of the flow diversion device in a continuous flow pasteurization system. This pen on a meter-based system only records the flow diversion device position that has been electronically signaled by the flow recorder/controller.

Heat Exchanger: Equipment designed to effect heat transfer between two or more mediums (plate type, triple tubes, etc.).

Holding Tube: The section of piping in continuous flow pasteurizers of sufficient length to provide the minimum legal residence time for heated milk.

Meter Based System: The term used for those pasteurization systems employing the use of approved components of a magnetic flow control system to replace other conventional timing pumps in a HTST system.

Microswitch: A mechanically activated electric NO (normally open), NC (normally closed) switch. It is a small level actuated switch used in the control circuit and is sometimes referred to as a limit switch. Microswitches may have three terminals, one to supply current, and two others marked "NO" for normally open and "NC" for normally closed. External pressure on the lever will change the position from "NO" to "NC" or vice versa, depending on the switch wiring. Used to "break" or "make" a control circuit.

Milk: Lacteal secretion of cows, sheep, and goats.

Non-processing distributor: Person who sells fluid milk in consumer-sized units under the person's own brand or trade name after the milk has been processed and packaged by a distributor or producer-distributor.

Regenerator By-Pass Valve: A automatic or manually controlled valve used in combination with the booster pump for the purposes of startup of a continuous pasteurizer with a milk to milk regenerator. This valve allows for by-passing the regenerator in order to provide the proper pressure relationships in the regenerator, thus allowing the booster pump to operate.

Safety Thermal Limit Controller: The term sometimes used interchangeably when referring to the recorder-controller.

Time Delay Relay: An adjustable timer (either mechanical or electronically controlled) used to maintain a set time period equal to or greater than the required minimum. All required TDR's must be sealed by the regulatory agency.

Timing Pump: Sanitary, positive displacement type (rotary or piston) or in the case of meter based systems a centrifugal product pump, which provides a constant measured rate of flow to the continuous pasteurization system. Homogenizers may be used as timing pumps since they are piston type (always odd numbers of pistons) pumps and positive displacement pumps. All timing pumps are capable of creating suction and do not slow down under discharge pressure.

Pasteurization: Process of heating every particle of milk and milk products to the minimum required temperature (for that specific milk or milk product), and holding it continuously for the minimum required TIME in equipment that is properly designed and operated.

pH: pH is a scale from 0 to 14. It measures acidic or alkaline a substance is. More acidic solutions have a lower pH. More alkaline solutions have a higher pH.

Producer: A person who engages in the production of unpasteurized milk on a dairy farm and does not bottle the milk on the premises where production occurs, in pasteurized or unpasteurized form and for human consumption.

Producer-distributor:

- (a) A person who bottles milk on the premises where production occurs, in pasteurized or unpasteurized form and for human consumption.
- (b) A person who purchases milk from a producer, pasteurizes that milk, then bottles it for distribution.

Ultra-pasteurization (UP): When used to describe a milk and/or milk product, means that such milk and/or milk product shall have been thermally processed at or above 138°C (280°F) for at least two (2) seconds, either before or after packaging, so as to produce a milk and/or milk product, which has an extended shelf-life under refrigerated conditions. (Refer to 21 CFR 131.3.)

Vacuum Breaker: An air relief valve held in the closed position by product flow pressures and which opens and admits air when the product pressure goes below atmospheric pressure. Uses include maintaining proper pressures in a milk to milk regenerator during system shut-down and preventing suction of product past the flow diversion device during operation. Other uses are to provide protection on pasteurized installed vacuum chambers.

Water Activity (a_w): Water in food which is not bound to food molecules can support the growth of bacteria, yeasts and molds (fungi). The term water activity (a_w) refers to this unbound water. Higher a_w substances tend to support more microorganisms.

V. RULES AND REGULATIONS

The following are from the Oregon Revised Statutes (ORS) Chapter 621, the Oregon Administrative Rules (OAR) Division 24, and the Pasteurized Milk Ordinance (PMO).

OAR 603-024-0490 Qualifications

- (1) Applicants for dairy operators' licenses shall be:
 - a. Able to read and write legibly
 - b. At least 18 years of age
 - c. Free of communicable diseases
 - d. Pass written and practical examinations
 - e. Pay required fees
- (2) Applicants for HTST/HHST pasteurizer operator licenses shall have:
At least two months (60 sessions) practical experience helping to operate pasteurization equipment

OAR 603-024-0492 Examination of Applicant

- (1) Written examination shall include questions relating to:
 - a. Knowledge of laws and regulations relating to activity for which the license is desired
 - b. Theory and practice involved in the performance of the licensed activity
- (2) Practical examination shall include demonstration of ability to:
 - a. Make required quality control tests
 - b. Operate required equipment
 - c. Manufacture, grade, test, or pasteurize milk and milk products, as the case may be
 - d. Care, cleaning, and maintenance of equipment and utensils involved in the licensed activity

VI. LICENSE AND FEES

- (1) License:
 - a. Expires on June 30 of each even-numbered year
 - b. Renewed by the licensee
 - c. May be suspended, revoked, or limited
 - d. May be subject to retraining
 - e. Belongs to the individual, NOT the employer or equipment
- (2) Fees:
 - a. Established by ODA in accordance with ORS chapter 183 and shall not exceed \$50.
 - b. Non-refundable
 - c. Late fees applied if renewal fee is past due

VII. INTRODUCTION

The purpose of Pasteurization is to:

- Destroy pathogenic/harmful bacteria
- Reduce total bacterial numbers
- Extend shelf-life of product (when refrigerated)

Types of Microorganisms

- Molds
- Yeasts
- Bacteria
- Viruses

Sources of Microorganisms in milk

- Cow, sheep, goat
- Dirty air
- Dirty water
- Soil
- Manure
- Bedding & feed
- Dirty equipment
- Personnel

VIII. GRADE “A” RAW MILK STANDARDS

Federal Limits:

- Bacteria
 - Non-Commingled (single producer): Not to exceed 100,000/mL
 - Commingled: Not to exceed 300,000/mL
- Somatic Cell Count
 - Non-Commingled (single producer): Not to exceed 750,000/mL

Oregon Limits:

- Bacteria
 - Non-Commingled (single producer): Not to exceed 80,000/mL
 - Commingled: Not to exceed 300,000/mL
- Somatic Cell Count
 - Non-Commingled (single producer): Not to exceed 500,000/mL

Grade “A” Raw Goat Milk Standards

- Bacteria: Not to exceed 80,000/mL
- Somatic Cell Count: Not to exceed 1.5mil/mL
- Coliform: Not to exceed 10/mL

Grade “A” Pasteurized Milk Standards

- Bacteria: Not to exceed 20,000/mL
- Coliform: Not to exceed 10/mL

Antibiotic Residue (Appendix N):

- Test result must be **NEGATIVE** for milk to be used in processing

NOTE: It is not allowed to test frozen raw milk samples for bacteria or somatic cells.

IX. HTST PASTEURIZATION

High Temperature Short Time or HTST pasteurization is the process of heating every particle of milk product in properly designed and operated equipment to meet the requirements in Item 16p. and Appendix H. of the PMO, to one of the temperatures specified in the following table and held continuously at or above that temperature for at least the time specified.

Continuous Flow (HTST and HHST) Pasteurization	
Temperature	Time
72°C (161°F)*	15 seconds
89°C (191°F)	1.0 second
90°C (194°F)	0.5 second
94°C (201°F)	0.1 second
96°C (204°F)	0.05 second
100°C (212°F)	0.01 second

*If the fat content of the milk product is ten percent (10%) or greater, or total solids of 18% or greater, or if it contains added sweeteners, the specified temperature shall be increased by 5°F (3°C).

Provided, that eggnog shall be heated to at least the following temperature and time specifications:

Continuous Flow (HTST) Pasteurization	
Temperature	Time
80°C (175°F)	25 seconds
83°C (180°F)	15 seconds

Inclusions:

All milk and milk products, i.e., milk solids, whey, nonfat dry milk, condensed milk, cream, skim milk, etc., eggs, egg products, cocoa, cocoa products, emulsifiers, stabilizers, vitamins and liquid sweeteners shall be added prior to pasteurization. Ingredients, which may be added after pasteurization are those flavoring ingredients and other ingredients which have been found to be safe and suitable such as:

- a. Ingredients permitted by the Code of Federal Regulations (CFR) “Standards of Identity” when considering a standardized milk or milk product;
- b. Fresh fruits and vegetables added to cultured milk and milk products provided the resulting equilibrium pH level [4.6 or below when measured at 24°C (75°F)] of the finished product is reached without undue delay and is maintained during the shelf life of the product.
- c. Ingredients subjected to prior heating or other technology, which has been demonstrated to be sufficient to destroy or remove pathogenic microorganisms;
- d. Ingredients having a Water Activity (a_w) of 0.85 or less;
- e. Ingredients having a high acid content [pH level of 4.6 or below when measured at 24°C (75°F)] or high alkalinity [pH level greater than 11 when measured at 24°C (75°F)];
- f. Roasted nuts;
- g. Dry sugars and salts;
- h. Flavor extracts having a high alcohol content;
- i. Safe and suitable bacterial cultures and enzymes; and
- j. Ingredients, which have been found to be safe and suitable by FDA.

All such additions shall be made in a sanitary manner, which prevents the contamination of the added ingredient or the milk or milk product.

X. BASIC HTST DESIGN AND FLOW PRINCIPLES

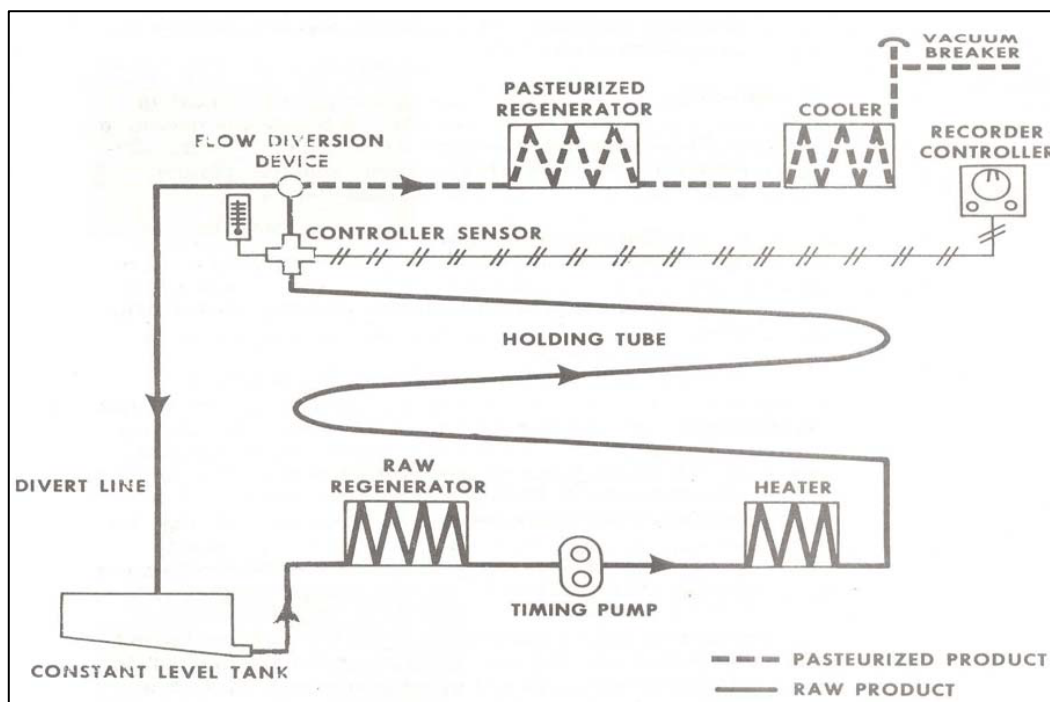

Basic HTST Flow

1. Cold Raw Milk enters the constant level tank (approximately 40°F) and is drawn under reduced pressure into the regenerator section of the press.
2. In the regenerator section, the cold raw milk is pre-warmed by the heat given up by the hot pasteurized milk flowing in a counter current direction on the opposite side of the milk to milk regenerator plates.
3. The raw milk, still under suction, is drawn through a positive displacement timing pump which delivers it under positive pressure through the remainder of the HTST system.
4. Under positive pressure the raw milk is pumped through the heater section where steam heated hot water on opposite sides of the stainless-steel plates continues to heat the milk to a temperature exceeding the minimum pasteurization temperature.
5. The hot milk, now at or above legal pasteurization temperature, and under pressure, flows through the holding tube where the transit time ("hold") is at least 15 seconds. The velocity or rate of flow of the milk through the holding tube is totally governed by the speed of the timing (metering) pump. We could say then that the residence time of the milk in the holding tube is determined by the

pumping rate of the timing pump, the length of holding tube, and the surface friction of the milk product.

6. The milk then contacts the sensing bulbs of the indicating thermometer and the recorder controller. If the milk temperature is not at or above the minimum required set point, then the sub-legal milk is returned back to the constant level tank via the diversion port and line of the flow diversion device.
7. If the milk contacts the STLR at or above the minimum set point (161°F), the recorder controller signals the flow diversion device to assume the forward flow position and the milk flows through the forward flow port of the flow diversion device. The milk from this point continues its flow through the system as legally pasteurized product.
8. The hot pasteurized milk then passes through the milk to milk regenerator (on the pasteurized side of the plates) and gives up heat to the cold raw product on the opposite side of the plate. In turn, the pasteurized milk is partially cooled.
9. The partially cooled pasteurized milk then passes through the cooling section, whereby re-circulated coolant water (sweet water or propylene glycol) is used to reduce the milk temperature to below 45°F.
10. The cold pasteurized milk then exits the cooler section and rises to an elevation of at least 12 inches above any raw milk in the HTST system and is opened to the atmosphere through a sanitary vacuum breaker at that point (or higher).
11. From this point, the pasteurized milk may travel directly to a storage or surge tank for subsequent packaging or may be returned back to the constant level tank.

XI. HTST EQUIPMENT AND FUNCTION

Constant Level Tank

Purpose/Function

- Supply milk to HTST at constant pressure
- Eliminate air in system
- Raw side of regenerator drain point
- Recirculation of sub-legal milk
- CIP supply tank

Design Criteria

- Sanitary construction
 - Stainless steel
 - Overlapping covers
- Separation of raw and pasteurized milk
 - Proper air gap to divert
 - Leak detect line (w/ Site Glass)
 - Recirculation line
- Overflow below lowest level of milk in raw regeneration section
- Outlet line remains flooded
 - Even when tank is empty

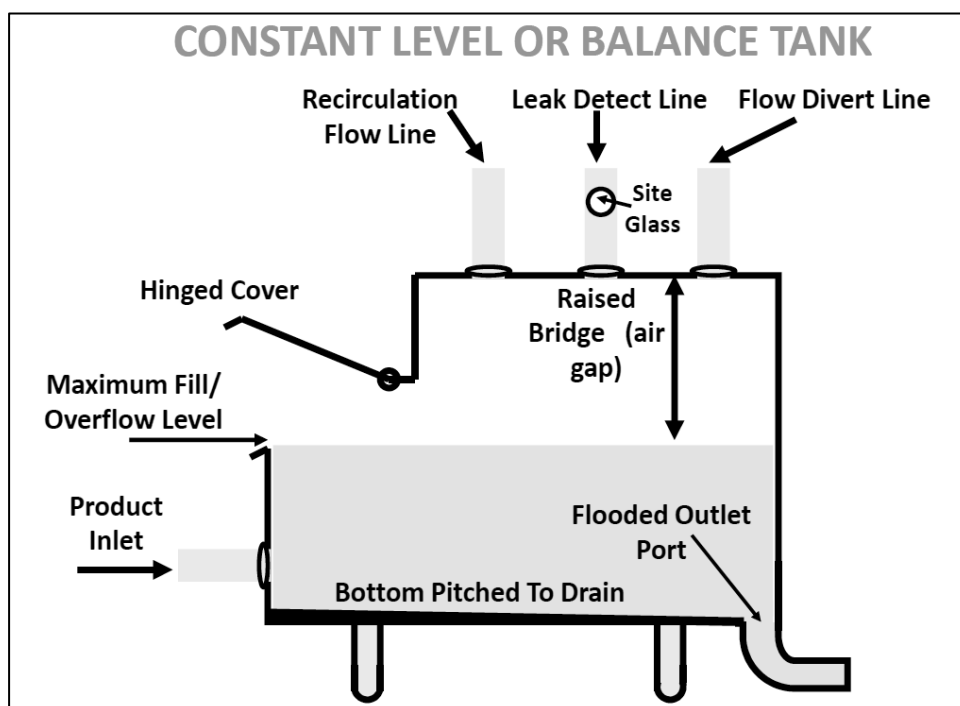

Raw Milk Regenerative Section

Purpose/Function

- Preheats raw milk by counter current flow to hot pasteurized milk
- Cools outgoing pasteurized milk
- Saves energy

Design Criteria

- Meet 3-A Standards
- At least 1 psi less than pasteurized side at all times
- Allow drainage of raw milk to constant level tank
- Deflector plate(s) drilled to allow drainage

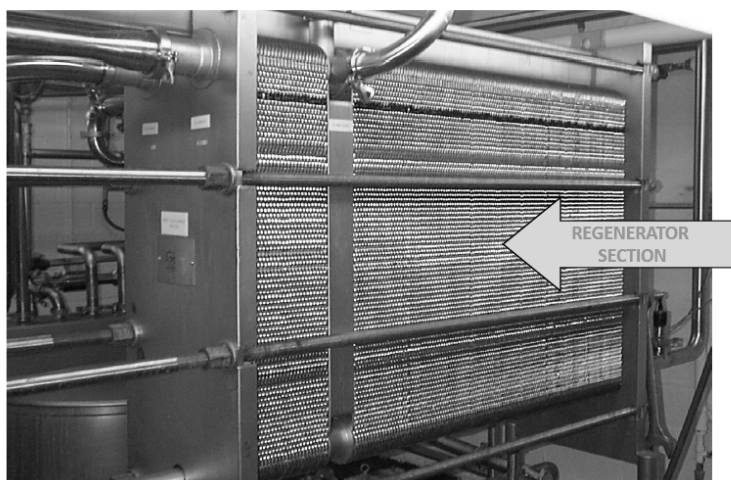
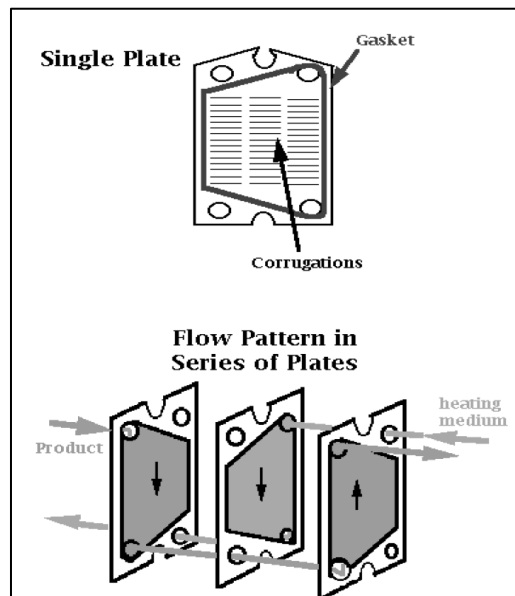

Timing Pump or Timing System

- Purpose/Function
 - Produce a constant rate of flow through hold tube
- Point to remember
 - Holding time is inversely proportional to flow rate
 - Speeding up flow/pump shortens hold time
 - Slowing down flow/pump increases hold time
- Design and Choices
 - Sets a maximum flow rate determined mechanically
 - PD pumps OR

- Senses flow & diverts FDD if Flow rate is exceeded
 - Meter based
- Mechanical Timing System Types
 - Positive Displacement
 - Rotary Lobe Pump
 - Single Speed-Gear or Belt
 - Variable Speed-Belt or Variable Frequency Drive
 - Piston Type
 - Homogenizer

P.D.P. - Rotary Type
(Positive Displacement Pump)

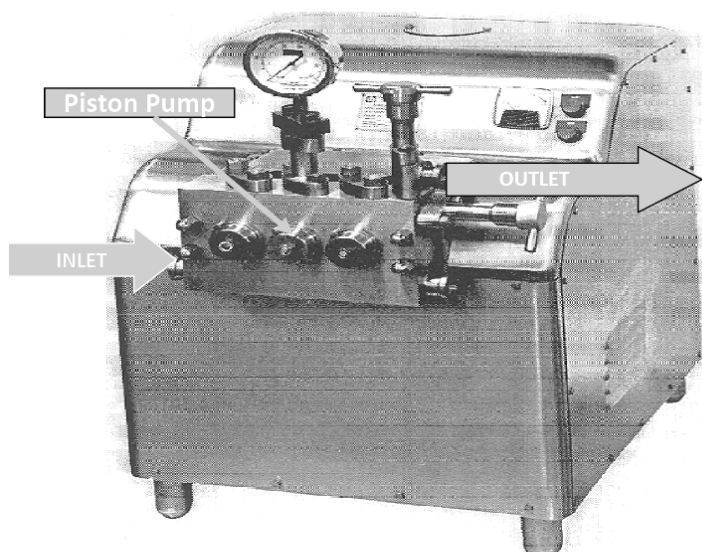
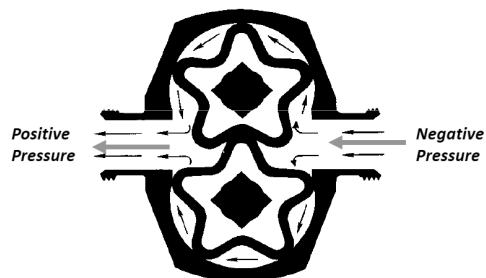

HOMOGENIZER WITH TWO STAGE
HOMOGENIZING VALVE
CHERRY-BURRELL

Meter Based Timing System

- Flow meter senses the product flow rate
- Flow meter sends proportional signal to alarm & recorder
- Recorder records flow
- Flow alarm diverts FDD if flow exceeds preset value
- Shall be piped in such a manner that at least ten (10) pipe diameters of straight pipe exists both upstream and downstream measured from the center of the meter.

Types

- Single speed
 - Centrifugal pump (60Hz)
 - Magnetic flow meter / Transmitter
 - Sanitary check valve
 - Flow control valve
 - Transmitter
 - Flow recorder / Controller w/ alarms
 - Flow diversion device
- Variable speed
 - Centrifugal pump
 - Variable Frequency Drive
 - Magnetic flow meter / Transmitter
 - Sanitary check valve
 - Flow recorder / controller w/ alarms
 - Flow diversion device

Heating Section

- Purpose/Function
 - Heating of milk to legal temperature prior to hold tube
- Design
 - Sanitary construction
 - Capable of heating product to the minimum legal temperature or higher, at the maximum flow rate

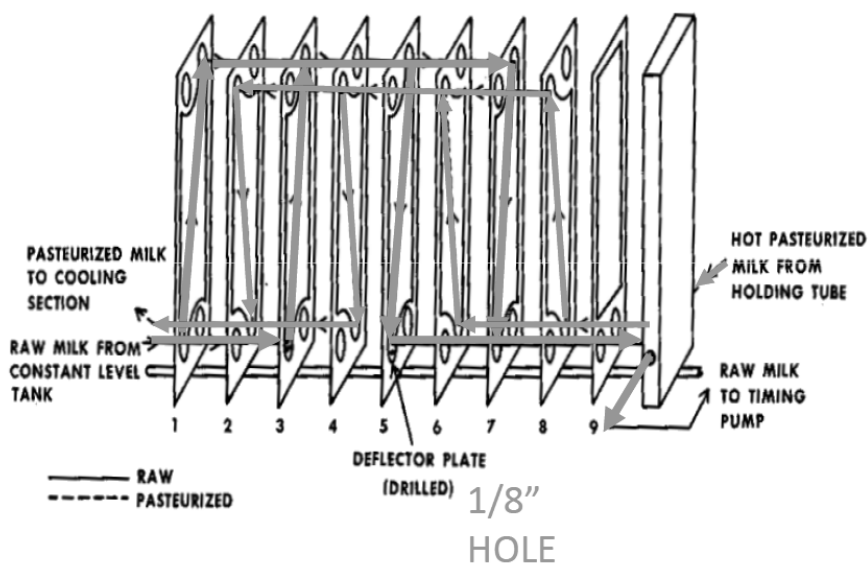

Holding Tube

- Purpose/function
 - Hold heated product for the required length of time (hold time)
- Design
 - Sanitary design
 - *Permanently supported at 1/4" per foot upward slope
 - Non-alterable
 - Begins at upward slope-ends at FDD
 - No more than 1°F variation in temperature
 - NOTE: Hold tubes shall not be climbed on. Climbing on holding tubes can alter the slope of the tube and put it in violation.

- Holding time
 - The minimum legal length of time product is to be held in the hold tube at a minimum legal temperature at a constant flow rate to assure proper pasteurization
 - Determined by flow rate and length of tube

*Do not stand on holding tubes. Standing on a holding tube may inadvertently bend it in a way that decreases the minimum ¼” per foot upward slope requirement.

Safety Thermal Limit Recorder (STLR)

- Chart Scale – PMO Requirements
 - 1°F Temperature Divisions
 - 12-hour chart – 15 minute divisions
 - Use the correct chart
- Sensor/RTD
 - Location – within 18”, upstream of FDD
 - Accuracy – within 1°F, not higher than indicating thermometer
 - Response time – 5 seconds or less
- Function
 - Controls FDD based on temperature
 - Records temperature of product
 - Event pen records position of FDD
- Chart information
 - Plant name and location
- Time accuracy
 - Correct elapsed time
 - 12-hour chart
- Date
- Pasteurizer identification if more than one
- Operators initials or signature
- Daily record of cut-in and cut-out temperatures
 - Cut in must always be higher than cut out
- Reading of indicating thermometer
- Amount and identity of each product in the run
- Record of any unusual occurrences
- Record of position of FDD

RECORDING THERMOMETER CHARTS

All charts used for the pasteurization of milk must contain **all** the following information:

1. Date
 2. Plant name and location
 3. Identification of pasteurizer (if more than one)
 4. Name or initials of operator
 5. Cut-in and Cut-out temperatures as checked at the start of the day's production
 6. Reading of indicating thermometer at the beginning of the process run and each time the chart is replaced with a new one for pasteurization runs longer than 12 hours
 7. Amount and identity of each product in the run
 8. Record of any unusual occurrences
- Charts must be neat and legible and contain NO overlapping information.
 - Charts must be retained for at least 3 months from the last regulatory inspection and retained for at least two (2) years after the date they were created.
 - Temperatures recorded on the charts shall verify that the higher minimum required temperatures for products containing added sugars or higher fats have been met.
 - Charts must show a record of the time(s) during a run when the FDD is in the forward-flow and/or divert position.

Indicating Thermometer

- Location - as close as possible to STLR sensor
- Accuracy +/- 0.5°F
- Response time - 4 seconds or less
- Scale 0.5°F divisions
- Reference thermometer
 - Daily check of recording accuracy
 - Daily check of cut in and cut out

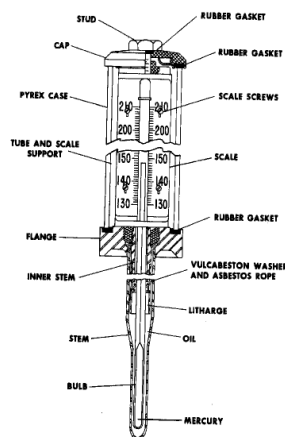

INDICATING THERMOMETER



Flow Diversion Device (FDD)

- Controls direction of flow
 - Divert or forward flow
- Position is controlled by
 - STLR (legal temperature)
 - SFLR (legal flow in meter-based systems)

Two valve seats

- Visible leak detect system between valve seats
- Failsafe
 - Spring to close
 - Divert upon loss of air pressure or electrical power
 - Microswitch
 - Not assembled properly at sub legal temperatures
 - Not fully diverted
 - Valves must assume the fully diverted position within the prescribed time (<1 sec)

Dual Stem

- Two 3-way valves
 - Divert valve
 - Leak detect valve
 - Sight glass located in line to balance tank to see FDV seat failure
 - Designed for CIP cleaning
- Modes
 - Product
 - Normal processing mode, valves are controlled by STLR & SFLR
 - Inspect
 - No flow through system allowed
 - CIP
 - If timing pump runs in CIP – A minimum ten-minute delay is required

Pasteurized Milk Regenerative Section

- Function
 - Hot pasteurized milk is cooled by heating the cold incoming milk
 - One thickness of metal separate raw and pasteurized milk
 - Pasteurized milk must always be at a higher pressure than raw milk

Vacuum Breaker

- Maintains proper pressure relationships
- Requires daily hand cleaning to ensure proper function
- Spring to close vacuum breakers are not allowed

Maintaining Pressure Relationships

- Design
 - The overflow of CLT must be lower than level of milk in Regenerator
 - Raw milk must enter the bottom of the Regenerator and freely drain back to CLT
 - All raw milk diverter plates must be drilled to allow downstream plates to drain
 - Pasteurized milk downstream of Regenerator shall rise at least 12” above the highest point of raw milk and open to atmosphere

Auxiliary HTST Components

Pumps

- Timing pump must be located between the outlet of raw regenerator and holding tube
- No pump, except properly installed Booster Pump may be installed between CLT and raw regenerator
- No flow promoting device can be located between outlet of Pasteurized regenerator and vacuum breaker

Booster Pump

- Purpose
 - Assist timing pump in moving raw milk from balance tank to raw regenerator
 - Increases regenerator efficiency
 - Reduces excessive vacuum and associated “flashing” of raw milk in the regenerator
- Location
 - Between balance tank and inlet to raw regenerator
 - Must be centrifugal design
- Controls
 - Inter-wired with timing pump
 - Shall only run when FDD is in forward flow position
 - Pasteurized pressure is 1 PSI higher than raw pressure in regenerator
 - 10-minute Time Delay before CIP is required
- Regenerator by-pass
 - Close coupled
 - Allows regenerator drainage on shut-down

Vacuum Chamber

- Purpose
 - Create negative pressure inside chamber causing product to flash off moisture
 - Used for rapid product cooling and flavor control
- May not
 - Interfere with operation of FDD
 - Adversely affect proper pressure relationships in regenerator
 - Reduce product holding time
 - Contaminate product
 - Add water to finished product
- Located on
 - Raw side
- Product removal pump to be inter-wired with timing pump
 - Pasteurized side
- Must valve out
 - On loss of power
 - Divert mode
 - Inspect mode
 - CIP (10 min)



Separator

- Purpose
 - Separation of whole milk used for partial or complete removal of milk fat particles (cream) from product
 - Exposes whole milk to centrifugal force through series of high speed rotating discs or plates
- Location
 - Raw product side
 - Valving interlocked with timing pump
 - Separator feed pump interlocked with timing pump
 - Pasteurized product side
 - Valving must be interlocked with FDD
 - Assure pressure relationships in regenerator
 - Does not apply negative pressure on FDD
- Valved-out as required

Homogenizer

- Can be a timing pump
- If not a timing pump it must be
 - Non-flow promoting
 - Cannot apply negative pressure to FDD
 - Does not decrease holding time
- Recirculation pipeline from inlet to outlet shall be the same size or larger than the feed pipeline

Evaporation Equipment Considerations

- Protect safe water supply
- Prevent negative pressure on FDD

Time Delays

- **Yoke Flush Time Delay**

At least one second between actuation of the divert valve and the leak detect valve, when moving from the diverted flow to the forward flow position. The reason for this is to flush the connecting line of any possible raw milk remaining in this connecting “yoke”. **On systems having identifiable restrictors in the divert line, the maximum time delay, (divert valve to leak detect valve "flush time") must never exceed 5 seconds.** This prevents sub-legal (< 15 seconds milk which may have been traveling down the UNRESTRICTED leak detect line) milk from entering into the pasteurized side of the system at the instant of forward flow. **This maximum 5 second flush delay does not apply to systems using a magnetic meter timing system.**

- **Inspect Time Delay**

When the mode switch is moved from the "PRODUCT “ or “PROCESS” position to the "INSPECT" position, the valve must immediately assume the DIVERT position and all flow promoting devices must be immediately de-energized. After all flow promoting devices have completely stopped (or have been effectively valved out of the system) the flow diversion device may move to the FORWARD FLOW position for inspection or servicing.

- **CIP Time Delay**

Timing pump or other flow promoting devices allowed to operate during CIP. Requirement – A 10-minute minimum time delay when the mode switch selector is placed in the CIP position. During this time period the FDD must immediately assume the DIVERT position and all product flow promoters which may induce improper pressure relationships within the milk-to-milk regenerator must be deactivated or effectively valved out of the system during the 10-minute time delay. This includes:

1. Booster pump
2. Raw milk separator between two raw side regenerators *(includes separator stuffer pump.)
 - Pasteurized milk separators*

*Separators are effectively valved out of the system, since separator plates will continue to spin even when power is not provided. They are powerful flow promoters. Following the 10 minute time delay, the system is under control of the CIP program, the valves may begin their cycling function and the booster and other auxiliary equipment may operate.

XII. CLEANING AND SANITIZING

Mere cleaning of equipment does not remove or destroy all disease-causing organisms that may have been present. Even very small numbers remaining may grow to dangerous proportions since many grow rapidly in milk. All milk equipment must be treated with a sanitizing agent just prior to usage. Cleaning must be thorough before sanitation can be effective since the presence of organic material such as milkstone and soil can inactivate the sanitizer.

Milkstone is a hard deposit or encrustation that is a combination of milk solids and washing powder that may build on milk equipment. The minerals contained in hard water also contribute to its formation. It is a chemical reaction that is accelerated by heat causing more deposits on heating surfaces than elsewhere. Aside from these contributing factors the primary cause of milkstone is improper cleaning.

Cleaners are designed to remove soils such as:

- Fat
 - Recommend temperature – 10°F over production temperature
 - Alkaline cleaner (caustic) – concentration designed for your system
- Protein
 - Alkaline or Acid cleaners
 - Oxidizing agents (chlorine) – typically not used on HTST units
- Carbohydrates
 - Alkaline cleaners
 - Acid cleaners
- Minerals
 - Acid cleaners
 - Specifically, designed cleaners

NEVER mix any acid products with chlorine or products containing chlorine. It produces deadly chlorine gas!

Factors which affect cleaning:

- Time - depends on:
 - Time of production run
 - Type of product run (soils)
- Temperature
 - Usually 10°F above process
 - Caustic wash is more temperature dependent for thorough cleaning
 - If wash solutions cool the soil may drop out and redeposit on the equipment
- Mechanical action – flow
 - Try to attain 1.5 times production flow
 - If using timing pump which uses impellers then remove and clean them
 - Install CIP pump
 - If washed with homo –use bypass

Sanitizing Methods

1. Steam

This method can be used successfully only in confined areas. All parts of equipment must be exposed to a temperature of at least 170°F for at least 5 minutes.

2. Hot Water

This method is difficult to use on assembled equipment, particularly where hot water flows over a surface cooler. The temperature and exposure time is the same as steam.

3. Chemical

An approved chemical sanitizing solution, such as chlorine, peroxyacetic, or quaternary ammonia is circulated or pumped through assembled equipment. Equipment may also be dipped in a solution to expose all the surfaces to the sanitizer.

The number and type of bacteria present in raw milk, faulty equipment, or soiled, un-sanitized contact surfaces of equipment may influence efficiency of pasteurization. Therefore, sanitation process protects product quality and safety.

XIII. TESTING OF PASTEURIZATION EQUIPMENT & FREQUENCY

Purpose of Testing

- To determine if controls are operating according to standards
- To satisfy regulatory requirements
- To help ensure safe product to the public

ODA inspectors conduct equipment check inspections according to PMO appendix I

Equipment checks are conducted:

- Initially upon installation
- At least once each three (3) months thereafter
- Whenever any alteration or replacement is made which may affect the proper operation of the instrument or device
- *In most cases when a regulatory seal has been broken

*Please check the “**Broken Seal Notices**” section of this manual for more information on when and how to notify the ODA of a broken seal.

What is tested

- Thermometers, temperature monitoring devices
- FDD (Flow Divert and Leak Detect Valves)
- Regen pressure controls
- Cut-in and cut-out
- *Continuous flow holding time (at least once every 6 months)
- Computerized controls
- Other required tests

* System must be clean AND free of residual sanitizer, otherwise the unclean system will hinder the timing of the system.

Item	Equipment	Test
1.	Vat, HTST, and HHST indicating and airspace thermometers	Temperature accuracy
2.	Vat, HTST, and HHST recording thermometer	Temperature accuracy
3.	Vat, HTST, and HHST recording thermometer	Time accuracy
4.	Vat, HTST, and HHST indicating and recording thermometers	Recording v. Indicating therm.
5.1	HTST and HHST FDD	Leakage pass FDD
5.2	HTST and HHST FDD	FDD freedom of movement
5.3	HTST and HHST FDD	Device assembly (single stem)
5.4	HTST and HHST FDD	Device assembly (dual stem)
5.5	HTST FDD	Manual diversion
5.6	HTST and HHST FDD	Response time
5.7	HTST and HHST FDD	Time delay (inspect)
5.8	HTST and HHST FDD	Time delay (CIP)
5.9	HTST FDD	Time delay (leak-detect flush)
6.	Vat leak-protector valve(s)	Leakage
7.	HTST indicating thermometers	Response time
8.	HTST recording thermometers	Response time
9.1	HTST pressure switches	Regenerator pressures
9.2.1	HTST and HHST differential pressure controllers	Calibration
9.2.2	HTST differential pressure controllers	Regenerator pressure
9.2.3	HTST* and HHST differential pressure controllers	Regenerator pressure
9.3.1	HTST booster pump/FDD	Inter-wiring check
9.3.2	HTST booster pump/timing pump	Inter-wiring check
10.1	HTST FDD	Temperature cut-in/cut-out
10.2	HTST* and HHST FDD divert system (indirect heat)	Temperature cut-in/cut-out
10.3	HTST* and HHST FDD divert system (direct heat)	Temperature cut-in/cut-out
11.1	HTST holding tubes/timing pumps (except magnetic flow meter based timing systems (MFMBTS))	Holding time
11.2.a	HTST holding tubes/MFMBTS	Holding time
11.2.b	HTST and HHST MFMBTS	Flow alarm
11.2.c	HTST and HHST MFMBTS	Loss of signal/low flow
11.2.d	HTST MFMBTS	Flow rate cut-in/cut-out
11.2.e	HTST MFMBTS	Time delay
11.2.f	All MFMBTS	High flow alarm response time
11.3	HHST holding tubes indirect heat	Holding time
11.4	HHST holding tubes direct injection heat	Holding time
11.5	HHST holding tubes direct infusion heat	Holding time
12.1	HTST* and HHST indirect heating	Sequence logic
12.2	HTST* and HHST direct heating	Sequence logic
13.	HHST	Pressure in the holding tube
14.	HTST* and HHST using direct injection heating	Pressure differential across injector
15.	HTST and HHST (all electronic controls)	Electro-Magnetic Interference

*For HTST systems with the FDD located downstream of the regenerator and/or cooling section

XIV. BROKEN SEAL NOTICES

Dairy plants shall notify the Oregon Department of Agriculture Food Safety Program by email and/ or Fax within 24 hours of when a regulatory seal has been broken. ODA inspectors will conduct equipment check inspections ASAP and re-seal the affected instrument or device on the pasteurizer.

What is sealed

- Temperature & flow recorder controllers
 - STLR & SFLR
- Temperature sensors
 - STLR RTD
 - DRT probe
 - DRT displays
- Booster pump controls
 - Differential pressure controller display
 - Differential pressure controller sensors
- Timing system
 - Timing pump (positive displacement pumps)
 - Variable frequency drives
 - Flow meters/transmitter/alarms
- Flow diversion valve timers
 - “Inspect”, “CIP”, “Flush”, timing pump off delays
- Computerized controls
 - PLC/Terminal strip inputs
 - R to I converter
- Any other public health control
 - Valve solenoids (if manually activated type)

Why break a seal?

- When a pasteurizing system malfunctions to the possible detriment of the public’s health and safety and needs immediate fixing
- Easy to identify issues include
 - Cut-in/cut-out temperature below 161°F
 - Improper valve function
- Pay attention to
 - Raw pressure sensor malfunction or reading below zero (0)
 - Mag-flow alarm malfunction
 - Recording pen malfunction



**OREGON
DEPARTMENT OF
AGRICULTURE**

Food Safety Program
635 Capitol St, NE, Salem, OR 97301-2532
503.986.4720 | Oregon.gov/ODA

Pasteurizer Broken Seal Notice

PLANT INFORMATION		
PLANT NAME:		TODAY'S DATE:
CONTACT NAME:	PHONE:	CITY:
PASTEURIZER ID:	PLANT NUMBER: 41-	SEAL LOCATION(S):
DATE SEAL BROKEN:	TIME SEAL BROKEN:	
REASON FOR BROKEN SEAL(S):		

ODA NOTIFICATION INFORMATION		
NAME OF ODA INSPECTOR CONTACTED:	DATE CONTACT MADE:	TIME CONTACT MADE:
HAS RESEAL BEEN SCHEDULED? <input type="checkbox"/> YES <input type="checkbox"/> NO	DATE SCHEDULED:	IS IT READY FOR TESTING? <input type="checkbox"/> YES <input type="checkbox"/> NO

After the dairy plant operator breaks a regulatory seal which has been applied by an assigned ODA Food Safety Specialist or after the pasteurization system malfunctions to the possible detriment of public health or safety, the dairy plant operator shall:

- Contact your assigned Food Safety Specialist to schedule an appointment for resealing the pasteurization system.
- Notify ODA Food Safety office by email or FAX with this Broken Seal Notice form within 24 hours of the broken seal. Send to foodsafety@oda.oregon.gov & sabrina.martinez@oda.oregon.gov

ODA FOOD SAFETY SPECIALIST CONTACT:					
Bestul, Zarina	Zarina.bestul@oda.oregon.gov	503-580-7302	Jensen, Neil	Neil.jensen@oda.oregon.gov	541-290-2397
Birdsall, Jeff	Jeffrey.birdsall@oda.oregon.gov	541-206-7059	Smith, Naaman	Naaman.smith@oda.oregon.gov	503-508-0470
Gieber, Chris	Christopher.gieber@oda.oregon.gov	503-784-6213	Wilson, Robert	Robert.wilson@oda.oregon.gov	541-660-9956
Jones, Lauren	Lauren.jones@oda.oregon.gov	541-969-2989	Leone, Julie	Julie.leone@oda.oregon.gov	971-209-5658
Ney, Melissa	Melissa.ney@oda.oregon.gov	541-969-8088	Harrang, Jon	Jon.harrang@oda.oregon.gov	541-480-8046

XV. BASIC HTST FLOW WITH SANITARY SEAL LOCATIONS

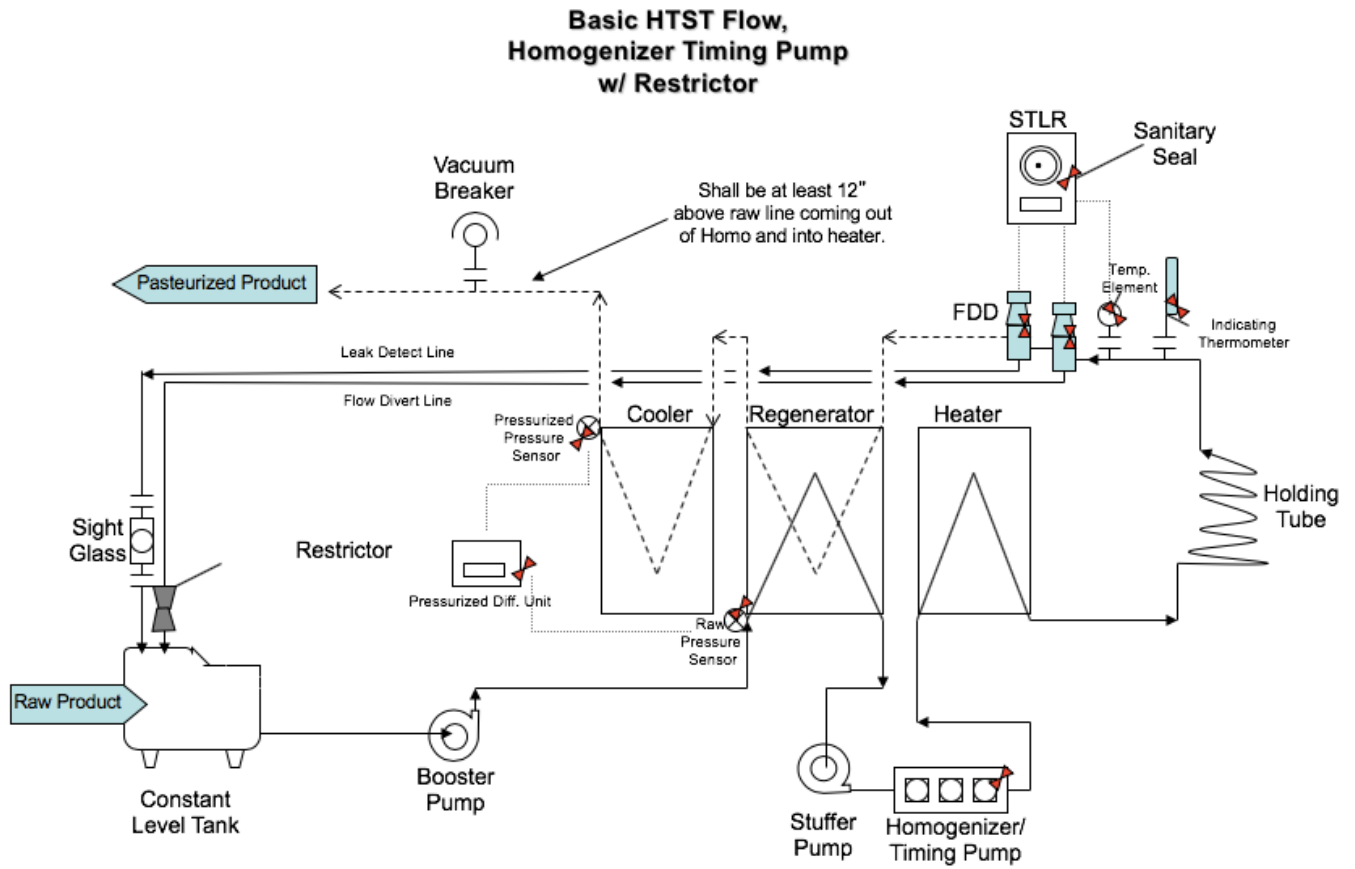

**Basic HTST Flow
w/ Meter Based Timing System
(Magnetic Flow Meter)**

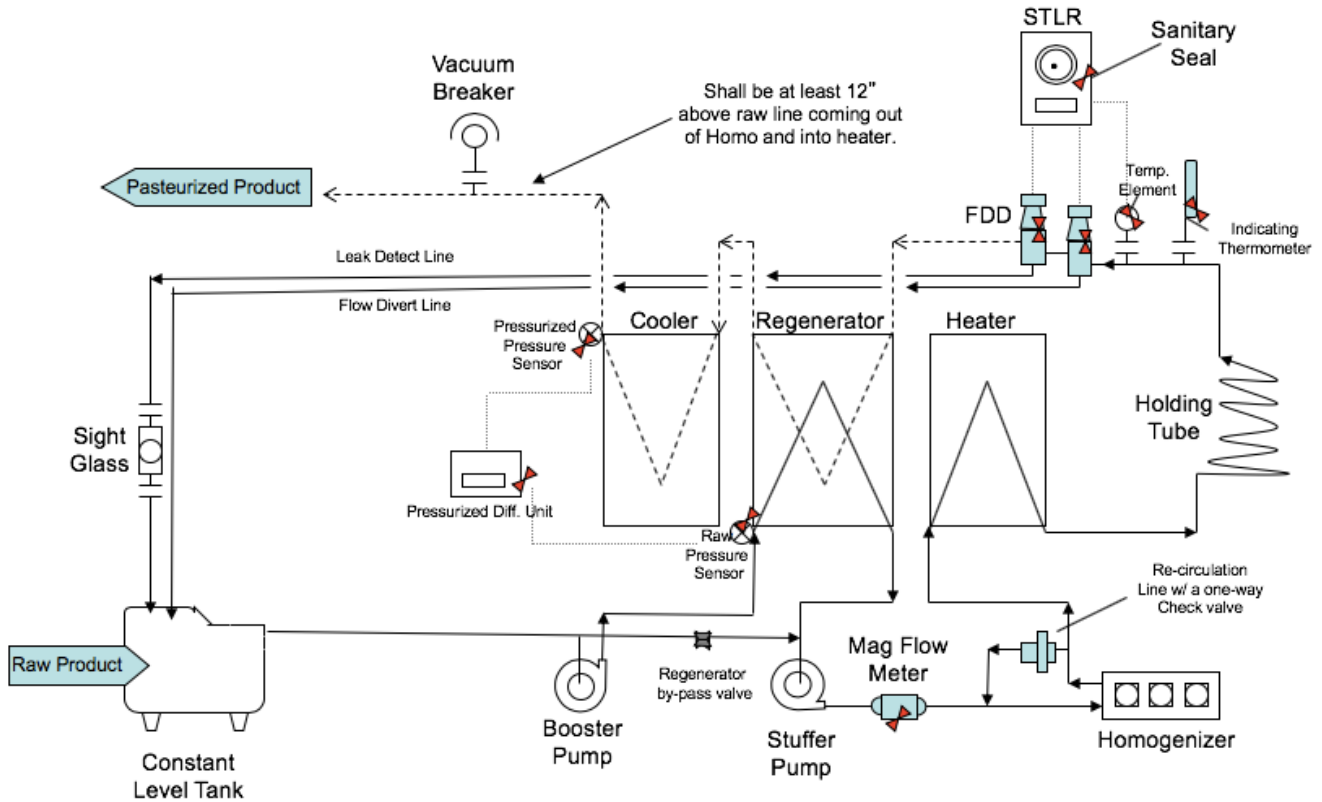

Basic HTST, No Booster Pump and Positive Displacement Pump

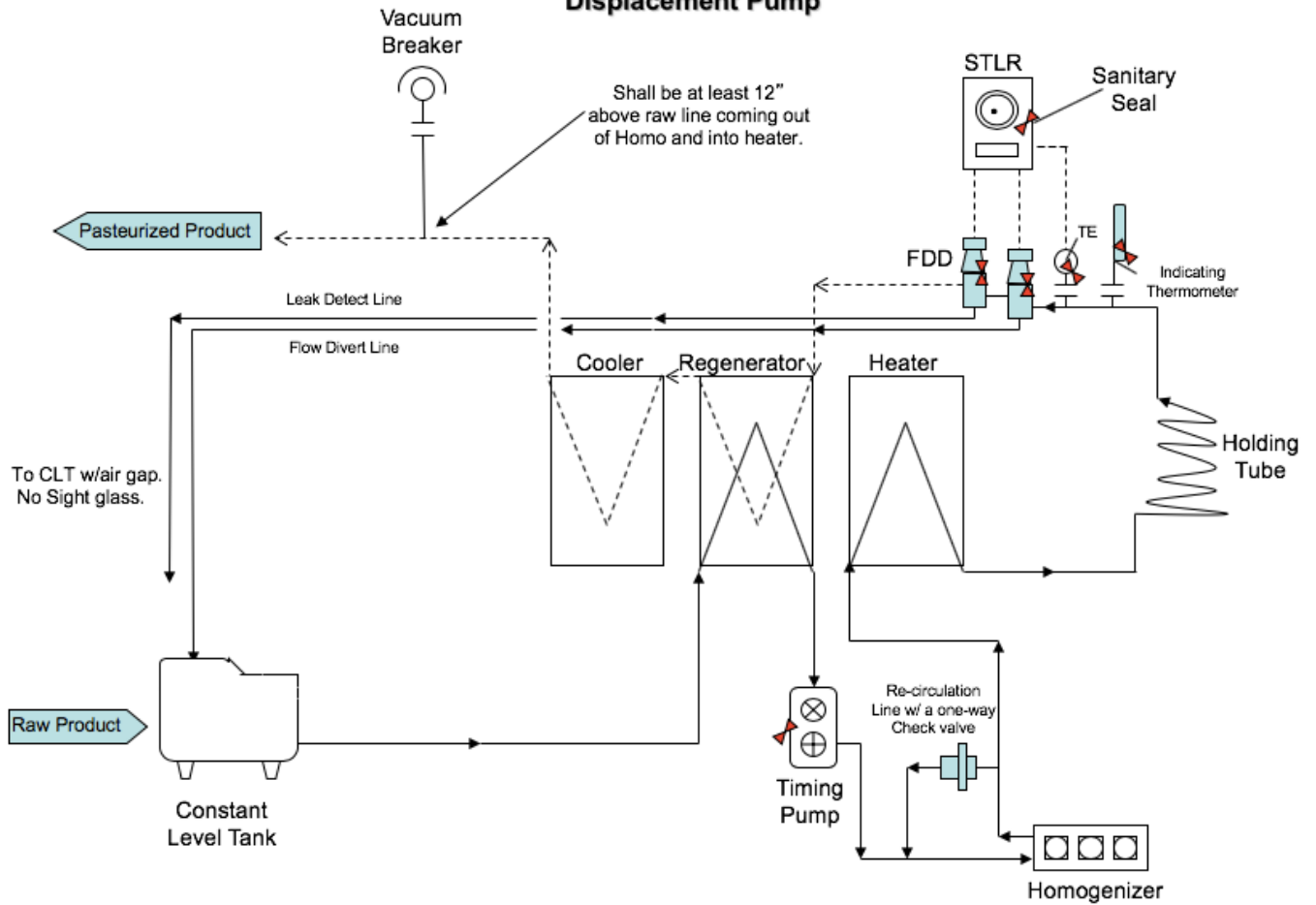

XVI. COMMON HTST PASTEURIZER COMPONENTS

1/8" Hole in Deflector Plate



• Photo by Thomas Starich

Plate Heat Exchanger



Single Speed PD Timing Pump

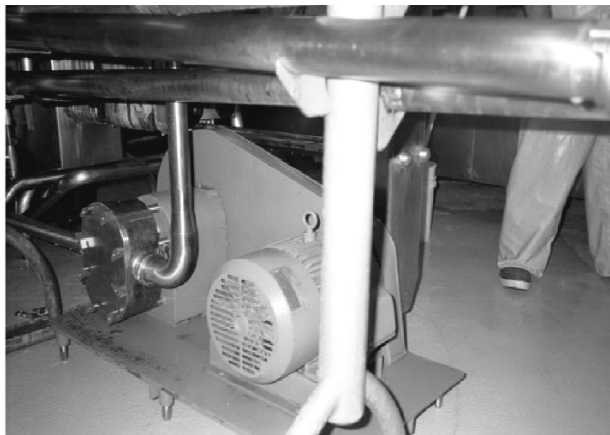

Variable Speed PD Pumps

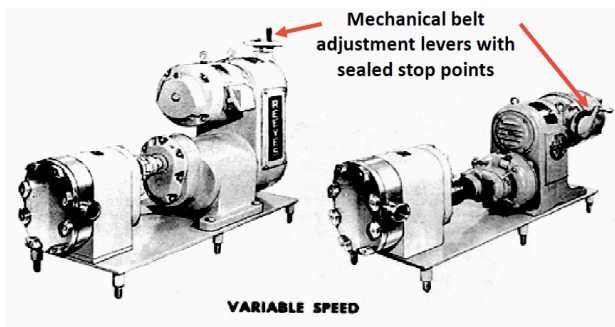

Tubular Heat Exchanger

Tubular Heat Exchangers

- a. Sanitary design and construction.
- b. Flow patterns.
- c. Proper maintenance and inspection
- d. Controls.

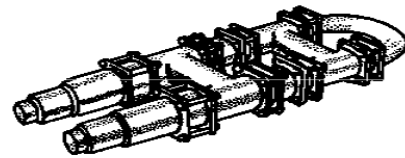

TRIPLE TUBE HEAT EXCHANGER CONSTRUCTION

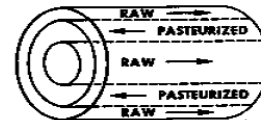

TRIPLE TUBE HEAT EXCHANGER

Vacuum Breaker

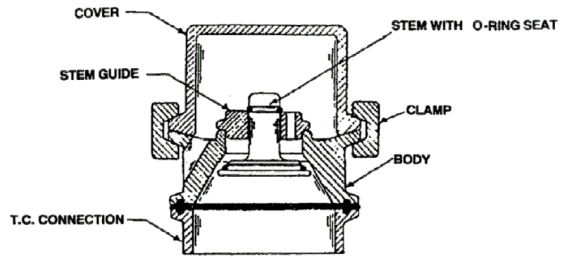

Pressure Differential Unit



Vacuum Breaker

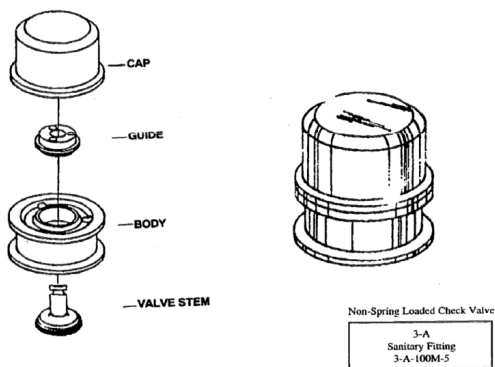



Alpha Laval-Tri Clover CIP'able Vacuum Breaker

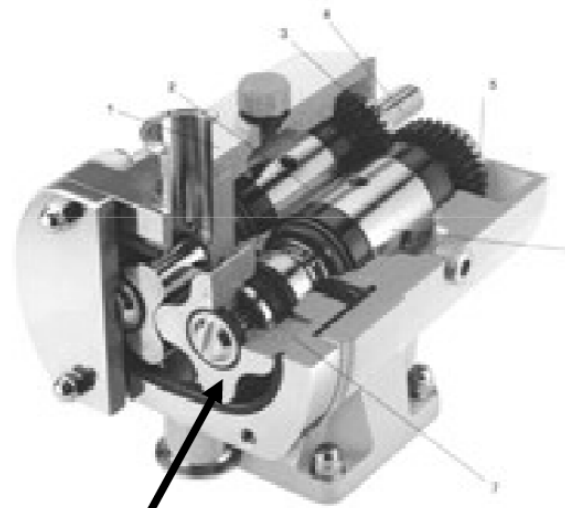
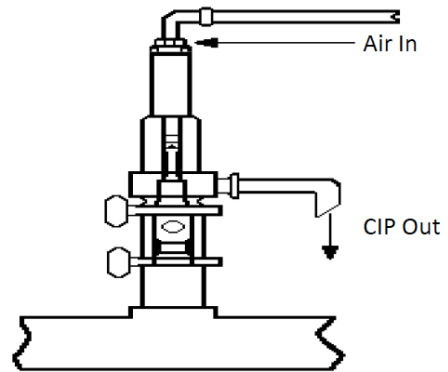

TWO LOBE IMPELLERS CREATE POSITIVE PRESSURE

Auxiliary Components



Note: The use of trade names or equipment photographs is for training and educational purposes only and does not constitute endorsement by the Oregon Department of Agriculture.¹
