

### Warranty Activation

To activate system warranty, FujiClean USA must receive Warranty Activation Card! Please see page 12.

## Contractor Installation Manual

### OREGON

### Residential Systems

### CEN5 Model

NEW: JULY 25, 2024

**Please Note:**

1. Product warranty requires proper system installation as described in this Manual.
2. It is the responsibility of the installing contractor to understand and adhere to all federal, state and local health and safety regulations.



Certified to  
NSF/ANSI Standards 40 & 245



## How to Use This Manual

**Note: You must be licensed by the Oregon Department of Environmental Quality (DEQ) as a certified licensed installer and certified by FujiClean USA or one of its authorized distributors to install this system.**







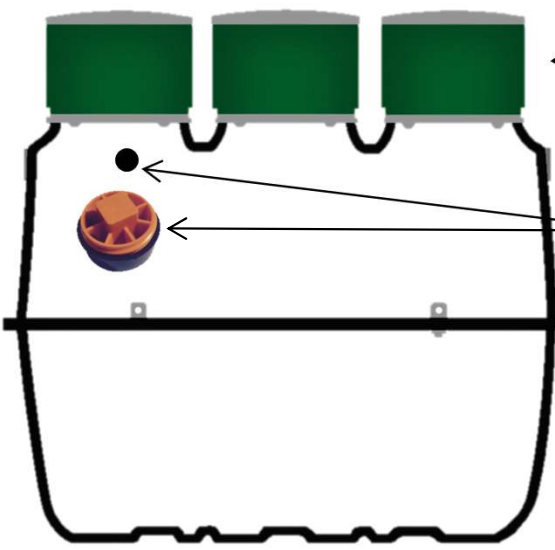
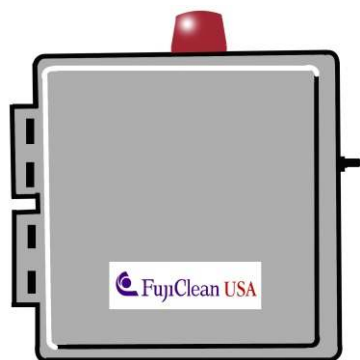
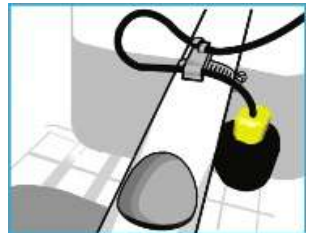
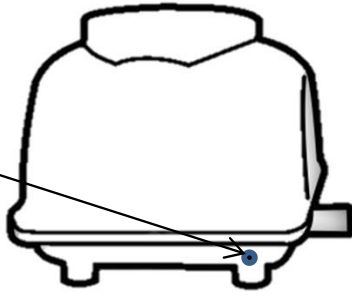

- Use the checklist provided in this abbreviated manual to assure proper installation of the FujiClean treatment system.
- Please contact your distributor or FujiClean USA with any questions. The FujiClean USA office number is 207-406-2927

## Oregon Installation Notes

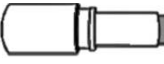
1. **Applicable only to the CEN5** – The DEQ approves model series by specific model. At this time, the CEN5 is the only approved FujiClean model.
2. **Approved Installation Configurations** – This manual includes general illustrations to visualize installation concepts. The DEQ-approved installation configurations are provided in this manual.
3. **Anti-Buoyancy** – FujiClean can provide anti-buoyancy alternatives. Please contact your authorized distributor or FujiClean USA if you need assistance.
4. **Approved Control Panel** – The Oregon-approved “fail-safe” control panel is provided in this manual.

Thank you for choosing to install a FujiClean USA treatment system. We care that the system is installed properly and thoughtfully. FujiClean USA or your qualified distributor will train and certify you for proper installation. PLEASE contact your distributor or FujiClean USA for assistance or with ANY questions.

## Equipment Supplied to Contractor

- Risers & Covers (height may vary – check with local distributor)
- Alarm / Control Panel (NEMA 4X Rated)
- Air Vent Hole and Plug (Tighten clockwise. Plugs the vent hole if venting through house)
- FujiClean Processor
- Signalmaster Float Switch (Affix to pumpback line in center chamber with 3-1/2" tether)
- Airline to Blower Adapter (Unglued. Glue clamp during installation.)
- Airline to Tank Adapter (Unglued. Glue during installation.)
- FujiMAC Air Blower
- Pressure Line Barb (Screws with rubber washer into blower)
- 1/8" (ID) Micro-Tubing for Air Pressure Alarm
- Installation Manual
- Owner's Manual
- Warranty Card
- NSF Dataplates (2)

Both airline to tank adapter combinations are acceptable. FL rules on pp 2-3 apply.

# Contractor Installation Manual – Residential Systems

## Equipment Supplied by Contractor

### Risers and Covers per Site & Regulatory Requirements

*Note: Tuf-Tite and Polylok Risers in 6" or 12" height increments and covers are available from your distributor. The maximum bury depth is 24" or less.*

**Note: If risers are not used, contractor must seal opening between with gray access port frame and tank with Oregon approved butyl sealant meeting ASTM C 990-96 standards for all three access ports.**



### Septic Tank and/or Pump Station.

The CEN5 can receive wastewater discharged directly from a dwelling; an upstream septic tank is usually not required..

### Fresh Water

Systems must be filled with fresh water to Low Water Mark (LWM) before start-up. The CEN5 will require approximately 610 gallons of water.

### Piping/Conduit

- 4" Schedule 40 for inlet and outlet lines.
- ¾" PVC conduit for air line (minimum 6-in. deep).
- Electrical conduit for float switch line (or use direct burial line).

### Electrical

- Please use licensed electrician and adhere to applicable national/local electrical code(s).
- Two (2) standard 115V, 15A circuits for control/alarm panel connection.
- Float Switch Wire: #18 AWG (comes with standard 30'-ft. length). May extend up to 50-ft.
- Float Switch: May come pre-installed in treatment system. For electrical hookup, please refer to SJE Rhombus installation instructions.
- Miscellaneous fittings and connectors to assure watertight connections.

### Anti-Buoyancy, if necessary

- Please refer recommendations in this manual or contact your distributor or FujiClean USA.

### Materials for Blower / Controller Installation

- Concrete base (or equivalent) on which to set air blower.
- Protective cover for air blower (vented and able to achieve free airflow in all conditions).
- Materials or location on which to mount control panel and protect from elements.

### Crushed Stone, Fill, Loam etc.

- FujiClean USA is not responsible for design, installation or materials associated with leachfield or treated wastewater disposal area.

**Please note: Proper installation permitting is the responsibility of the installing contractor.**

# Installation Overview

FujiClean recommends a protective housing with solid base for blower placement. Contractor to supply material to locate and mount the alarm/control panel.

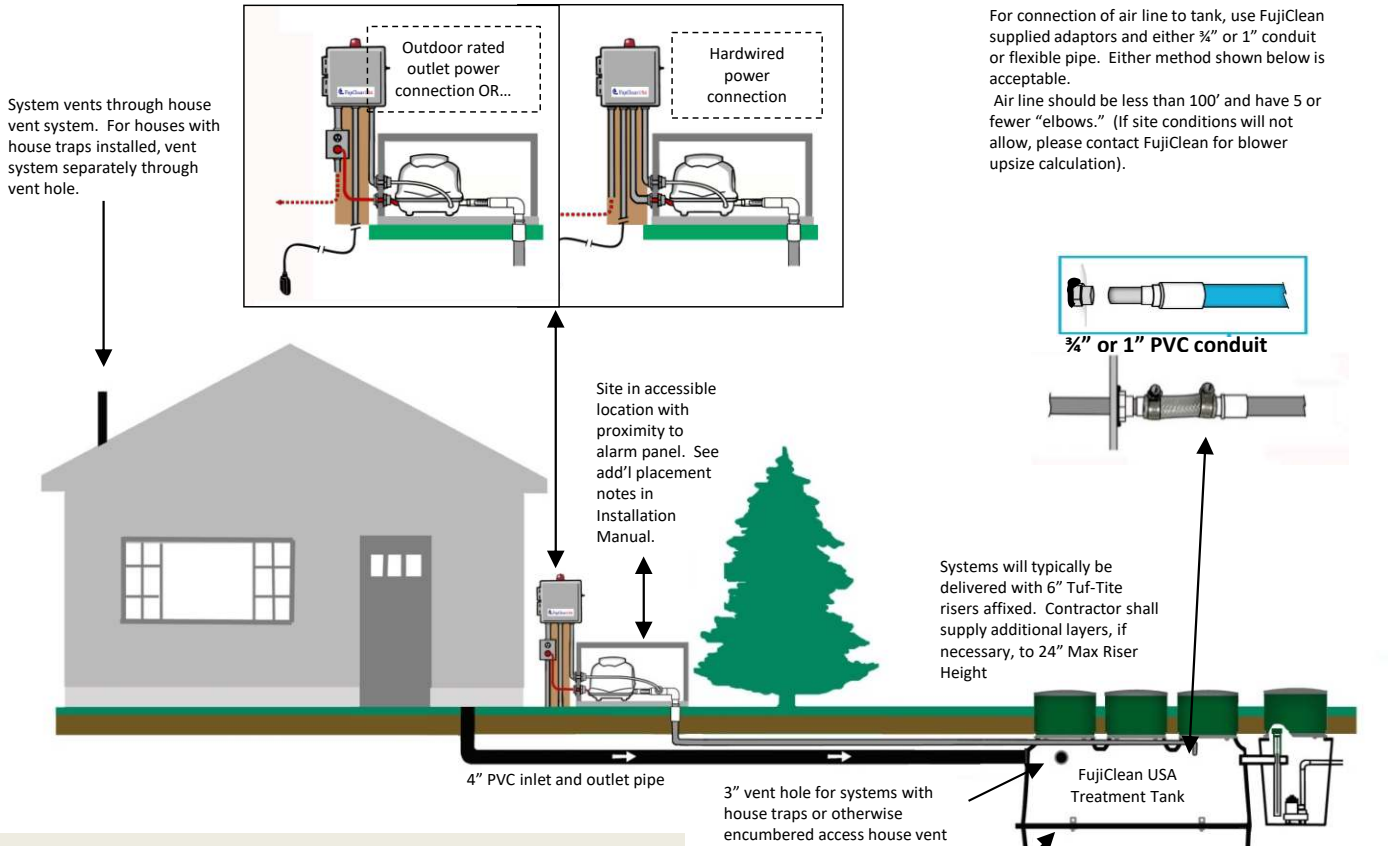

For connection of air line to tank, use FujiClean supplied adaptors and either 3/4" or 1" conduit or flexible pipe. Either method shown below is acceptable.  
Air line should be less than 100' and have 5 or fewer "elbows." (if site conditions will not allow, please contact FujiClean for blower upsize calculation).

Systems will typically be delivered with 6" Tuf-Tite risers affixed. Contractor shall supply additional layers, if necessary, to 24" Max Riser Height

## Please Note:

1. FujiClean systems are designed to accept wastewater directly from a dwelling and generally do not require a preceding septic or settling tank. DEQ-approved installation configurations are provided in this manual.
2. Fill tank with fresh water to LWL (Low Water Level) mark in all three chambers once tank is set.
3. "Clearwater" water softener backwash should be discharged directly to a footer drain (if regulations allow) or diverted around FujiClean system to drainfield.
4. Use a licensed electrician, as required, for final wiring.
5. Using grommets or a waterproof adhesive, affix NSF labels in two locations, inside the inlet riser and on the inside of the controller.
6. Installing contractor responsible for final landscaping, seeding etc. Be certain that final grade pitches away from treatment tank covers.
7. Final inspection and startup shall be the responsibility of the FujiClean USA certified O&M provider.
8. Homeowner manual must be provided to and reviewed with homeowner to assure proper use.
9. Warranty Card (orange card supplied by FujiClean USA), must be returned to FujiClean USA to activate warranty.

4-point lifting lugs. Use for setting tank. Tank must be level to within 1/8". Do not use lifting lugs for uplift restraint.

Bed tanks in 4"-6" sand or suitable (no rocks) native soil.  
Backfill in tamped lifts with suitable native soil, sand, peastone or equivalent that form fits to tank.

Fill set tank with fresh water to low water mark in all 3 chambers.

Please refer to DEQ-approved installation configurations provided in this manual.

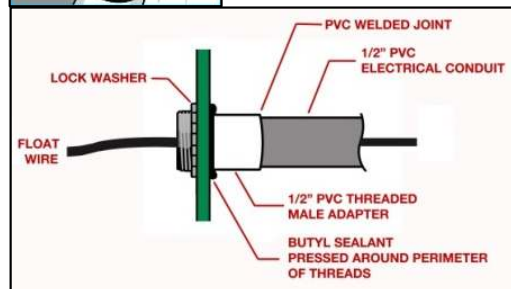
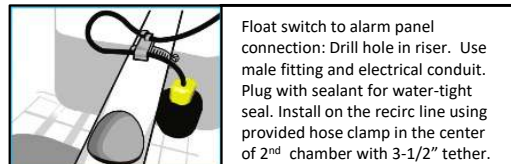



# Treatment Process Overview

FujiClean's "contact filtration" treatment is a simple, well engineered process that consists of a controlled, circuitous flow train through anaerobic and aerobic chambers and in direct contact with assorted proprietary fixed film medias on which biological digestion of organic matter occurs. Media is also designed and positioned to provide mechanical filtration of process wastewater.

The system includes two air lift pumps (see diagram below) The Recirculating Airlift Pump returns process water and sludge from the aerobic zone to the sedimentation chamber, recirculating 2-4 times inflow per day for CE models and 4-6 times inflow for CEN (enhanced denitrification) models. The Effluent Airlift Pump is designed to help equalize flow and discharge treated effluent.

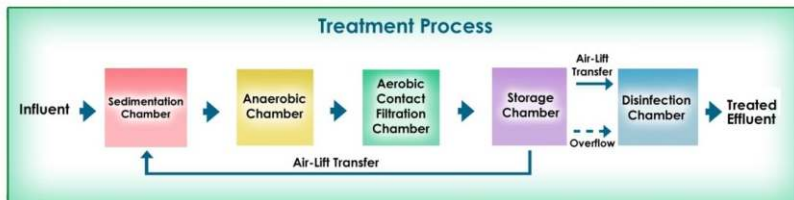

**Two Air Lift Pumps.** One Recirculating Air Lift pump sending process water and solids back to Chamber 1, and one Effluent Air Lift Pump for measured discharge of treated effluent. (See airlift pump info below).

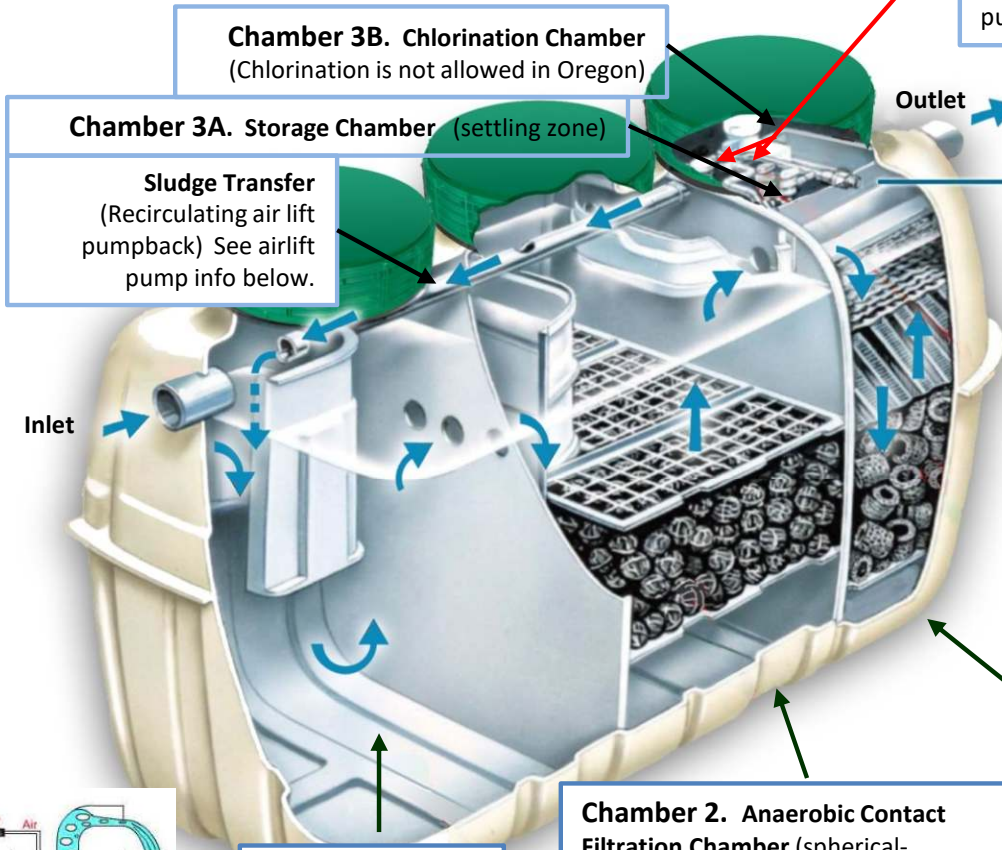

**Chamber 3B. Chlorination Chamber**  
(Chlorination is not allowed in Oregon)

**Chamber 3A. Storage Chamber** (settling zone)

**Sludge Transfer**  
(Recirculating air lift pumpback) See airlift pump info below.

Inlet

Outlet

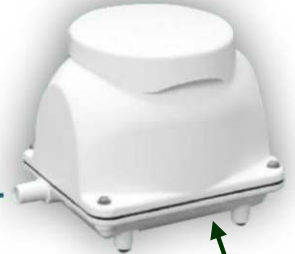

**Powered by the FujiMAC "R" Series Blowers** State-of-the-art linear diaphragm air blowers manufactured by FujiClean Co sized to provide about 2.8 cubic feet per minute to most residential systems.

**Chamber 3. Aerobic Contact Filtration Chamber**  
(both board and cylindrical hollow mesh media) oxygen rich zone for aerobic microbe digestion activity, solids filtration and nitrification of ammoniac nitrogens to nitrates

**Chamber 2. Anaerobic Contact Filtration Chamber** (spherical-skeleton filter media) organic matter decomposition by micro-organisms, suspended solids captured and nitrates are denitrified

**Chamber 1. Sedimentation Chamber** (separates solids and greases)

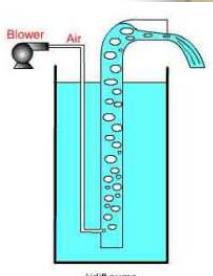

**Airlift Pumps.** This generic illustration shows the mechanics of the "airlift pumps" used in this system, which are simple pipe conduits through which pressurized air (from blower) is introduced at the bottom and by fluid pressure, water is carried up the pipe by ascending bubbles.

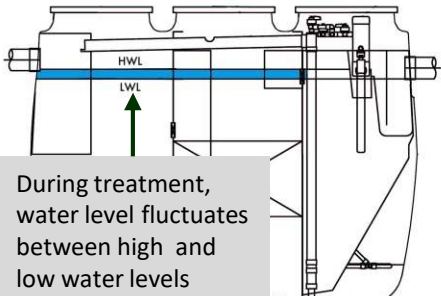

During treatment, water level fluctuates between high and low water levels

Overflow Effluent Weir

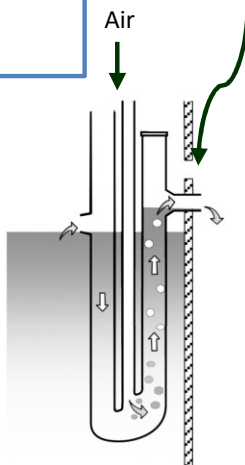

**Flow Equalization**  
When water level exceeds LWL, treated water is discharged through Chamber 3B via the Effluent Air Lift pump. If water level exceeds HWL, then treated water is also discharged through an overflow effluent weir.

# Installation Procedure

## Unloading Instructions:

- ❑ Upon delivery, inspect FujiClean tank, both outside and inside for possible damage incurred during transport. If you find damage, or have a question, please contact your distributor immediately.

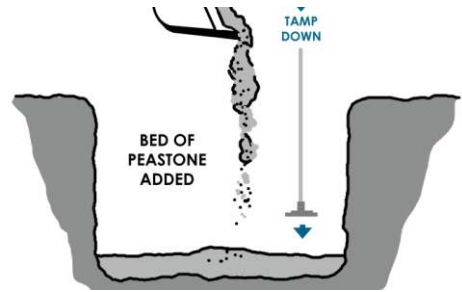
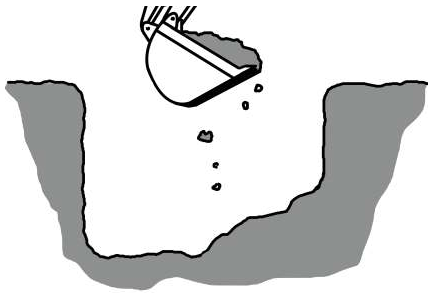

- ❑ **Step 1: Prepare excavation to be at least 1 to 2 feet larger than FujiClean system dimensions as listed below. Important Note: Riser height should not exceed 24".**

- ❑ **Step 2. Prepare 4"- 6" bed of stone (1/4" to 1/2"), level to within 1/8".**

FujiClean USA DESIGN SPECIFICATION TABLE	Note: The CEN5 is the only FujiClean model approved in Oregon.				Residential CEN Series BOD, TSS, TN (Enhanced Nitrogen Removal)			
Model					CEN5	CEN7	CEN10	CEN14
Tank Volume Total (gallons)					749			
Height (inches)					65.7			
Length (inches)					95.7			
Width (inches)					49.2			
Weight (lbs.)					463			
Inlet Invert (inches to 1/8")					53			
Outlet Invert (inches, to 1/8")					51			
Blower Size (Standard**)					80 L/min			
Power Use (kWh/day)					1.2			
<p>* TN data was obtained during CE testing, but not to NSF245 testing protocol. CEN testing was to NSF245 protocol.</p> <p>** Assumes blower siting conforms to parameters outlined in Step 8 of this Manual and site is below 10,000 ft. in altitude. If site is above 10,000 ft., please refer to table below for recommended blower sizing.</p>								

## Recommended blower sizing for site above 10,000 ft. above sea level.

Blower Capacity vs Altitude		
	Aerator Size (L/min)	
Model	0-10,000 ft	> 10,000 ft
CE5/CEN5	80	100
CE7/CEN7	80	100
CE10/CEN10	100	120

- ❑ **Step 3: Carefully lower and set tank. Level to within 1/8-inch.**

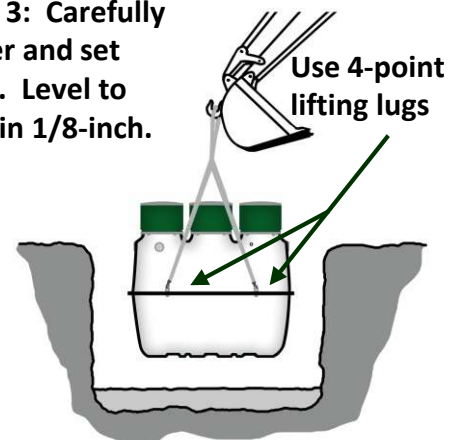

- ❑ Step 4: The installer shall install anti-buoyancy measures if the tank is subject to high groundwater. The installer should speak with the distributor or contact FujiClean USA for guidance, if necessary. Anti-buoyancy measures may include, but are not limited to, the following:
  - “Daylighting,” which is the installation of a French drain and piping system that discharges to the ground surface;
  - Monitoring Wells to establish groundwater elevation and acceptable tank pumping depth;
  - Deadmen and nylon strapping to resist uplift;
  - Geotextile and soil cover to provide sufficient overburden to resist uplift; or
  - Concrete slab system to resist uplift.

- ❑ Step 5: After rechecking that tank is level to 1/8-inch, (fore and aft as well as side to side), fill tank with fresh water to the low water line mark. Note: Alternate chambers while filling for evenly balanced fill.

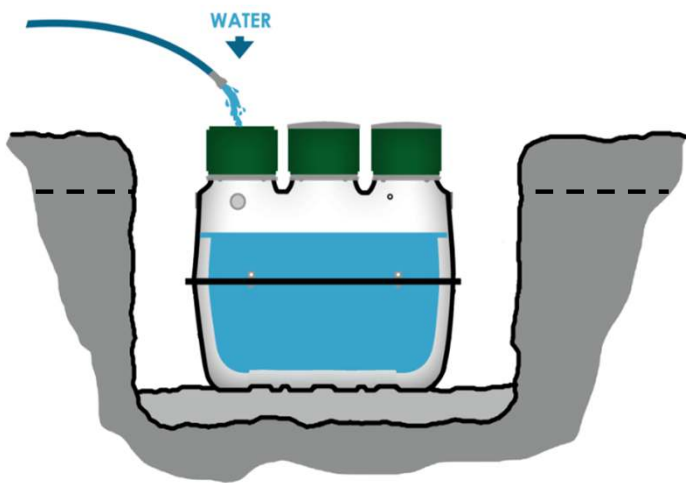

Low water line in sedimentation chamber



Please note: To assure tank water tightness, please check in 24 hours to be sure that the water level has not dropped. Please contact your distributor or FujiClean USA if water level has dropped.

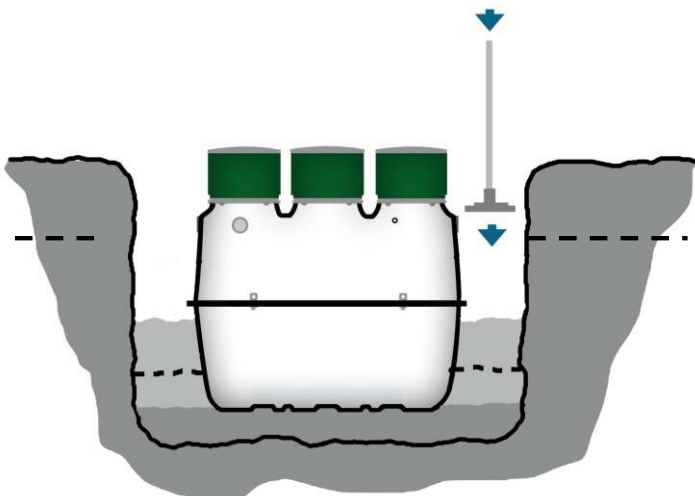

- ❑ Step 6: Backfill about ¾ way up tank in layered, compacted 6” lifts using peastone or equivalent material that form-fits into tank corrugations.



- ❑ **Step 7: Using supplied adaptors and fittings, attach air pipe fitting to tank and connect to ¾" or 1" conduit in prepared trench (min. 6" deep) to location of air blower. Please note: ¾" or 1" flexible irrigation line, 100 PSI Max, may also be used for the airline.**

Important: Oregon rules require use of sealant meeting ASTM C990-96 Standards to be applied behind the gray washer holding the airline fitting. Tighten washer.

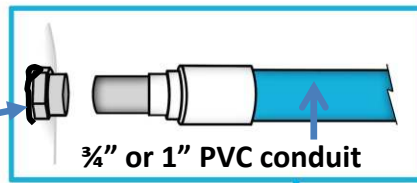

Note: A flexible airline adaptor may be used here. (Supplied by FujiClean USA in for Oregon installations.)

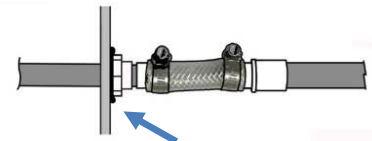

In Oregon, apply ASTM C990-96 compliant sealant behind washer. Tighten washer.

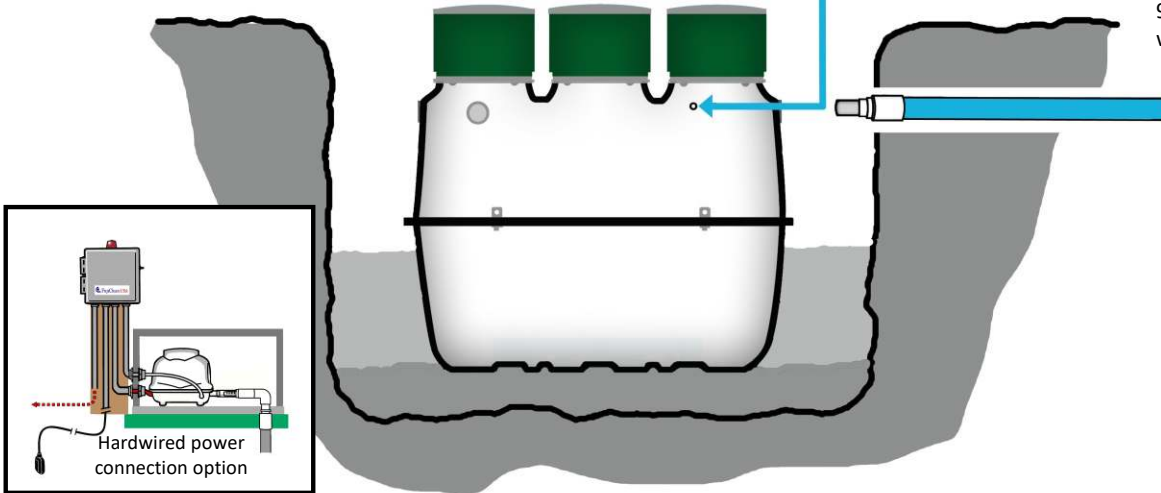

- ❑ **Step 8: Locating and Installing Blower/Control Panel.**

- ✓ **USING ¾-INCH CONDUIT, LOCATE BLOWER WITHIN 100-FT. (AIR LINE) OF TREATMENT TANK AND WITH NO MORE THAN FIVE (5) ELBOWS. If site conditions prevent this, please contact your distributor or FujiClean USA for technical assistance.**

**Air Blower shall be:**

- ✓ in as close proximity to control panel as possible
- ✓ on a solid (e.g. concrete) pad to minimize vibrations
- ✓ in a location above water level
- ✓ away from grease exhaust fans.
- ✓ away from bedroom windows and other locations where operational sounds (although minimal) may be a nuisance
- ✓ In a location that allows unencumbered access for inspection and maintenance activity
- ✓ with proper electrical grounding
- ✓ with wiring and electrical connections made by a licensed electrician.
- ✓ with no objects on top of electrical cord.
- ✓ in a well-ventilated space out of direct sunlight and protected from elements such as direct rain or snowfall.
- ✓ **Hardwired to power in states and jurisdictions that require a hardwired connection.**

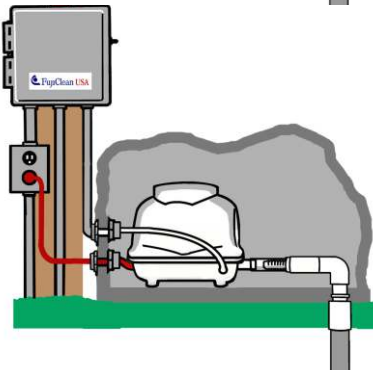
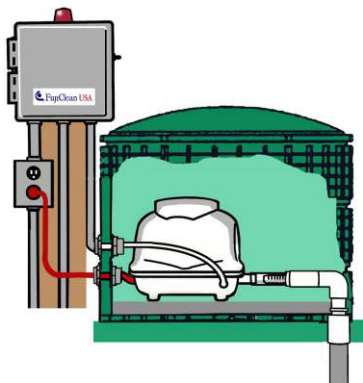

Two possible blower protection options. Be sure to vent covers to allow free air draw even in deep snowpack.

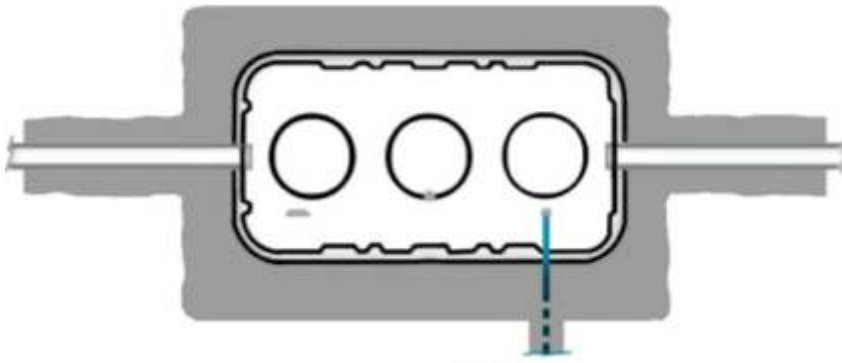

Plan view shows trench excavations for inlet and outlet lines

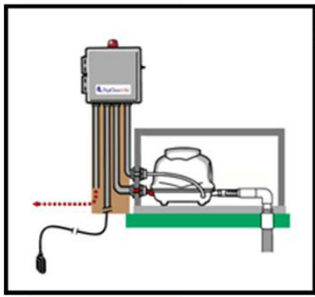

Note: Some states and installing contractors require hard wired blower connection

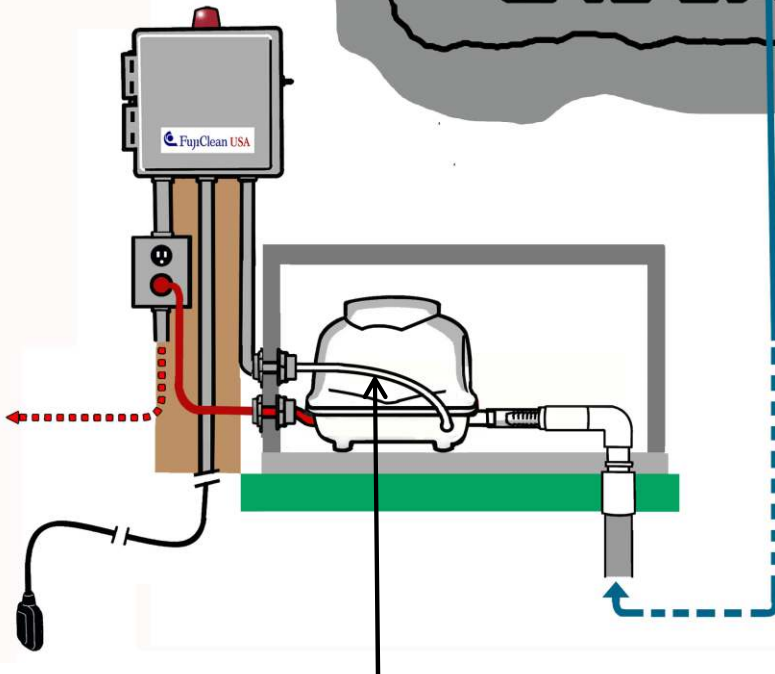
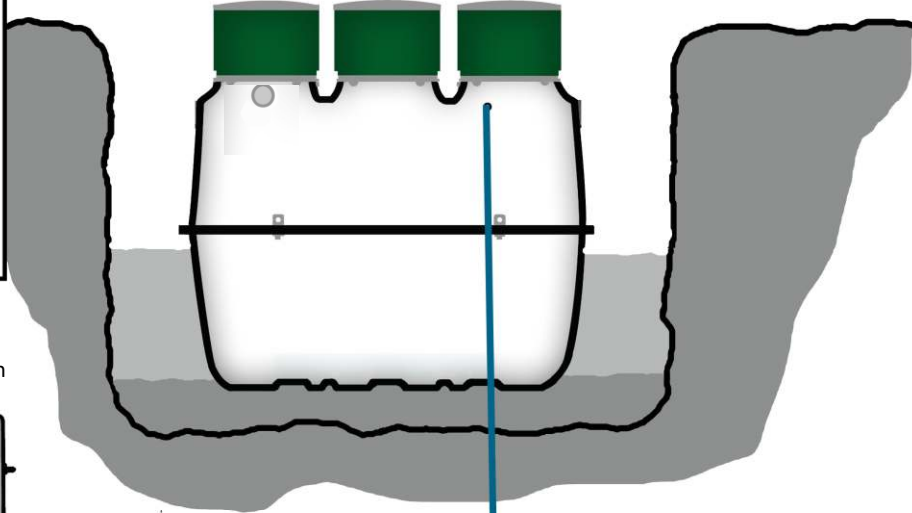

1/8" (ID) Vinyl Micro-Tubing for Air Pressure Sensing Alarm

❑ Step 8 continued: Locating and Installing Blower/Control Panel cont.

**Alarm Panel shall be:**

- ✓ in a well ventilated area as dry and protected from elements as possible
- ✓ in as close of proximity to FujiMAC Blower as possible
- ✓ wired by qualified electrician
- ✓ in a location that allows unencumbered access for inspection and maintenance activity

❑ For additional important detail about installing and maintaining blower, please review and refer to provided FujiMAC Blower Installation-Maintenance Manual, which is provided inside the blower box.

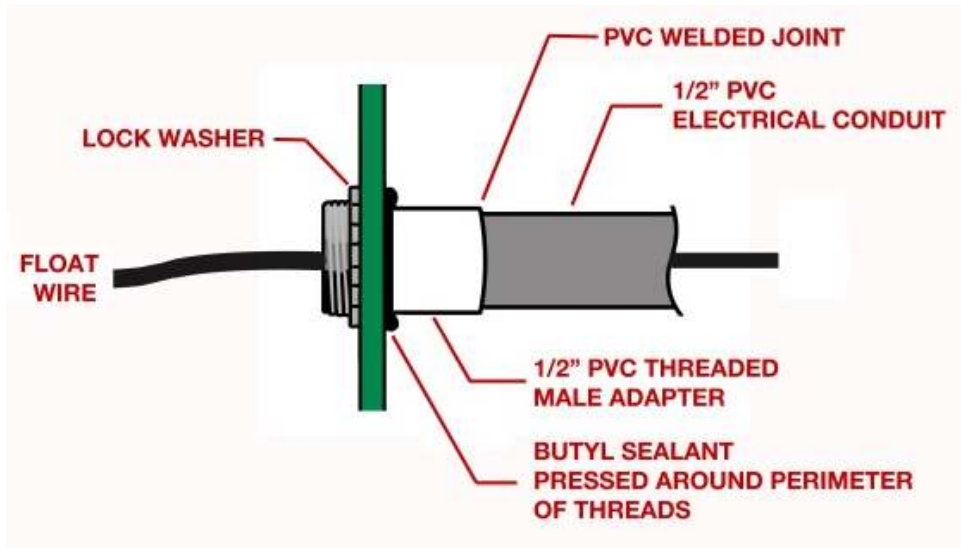

For connection of float switch cord to alarm panel, drill hole in riser and use male fitting and electrical conduit. Plug fitting with sealant standard that meets ASTM C990-96 to assure watertight seal and to prevent septic gas transmission into control panel.

- ❑ **Step 9: Install Float Switch on pumpback line in 2<sup>nd</sup> chamber with 3-1/2" tether. Float switch electrical cord should exit riser wall through male adaptor (caulked watertight to prevent gas leakage) or watertight fitting. An interior connection to direct burial cable is also acceptable.**



3-1/2" tether for float switch

- ❑ **Step 10: Prepare Tank Inlet and Outlet for 4" Sched. 40 Inlet and Outlet Lines**



**Apply primer and cement to 4" PVC inlet and outlet pipe sections.**

**Seal around inlet and outlet tank fittings using a sealant that meets ASTM C990-96 standards**

- ❑ **Step 11:** In nearly all cases, the FujiClean system will vent properly through the house septic influent line. In cases where there is a influent pump, or in severe downdraft locations, a separate vent should be considered. If you do choose to install a vent, be sure that the vent slopes toward the tank so that any moisture accumulation drips back down toward the tank.

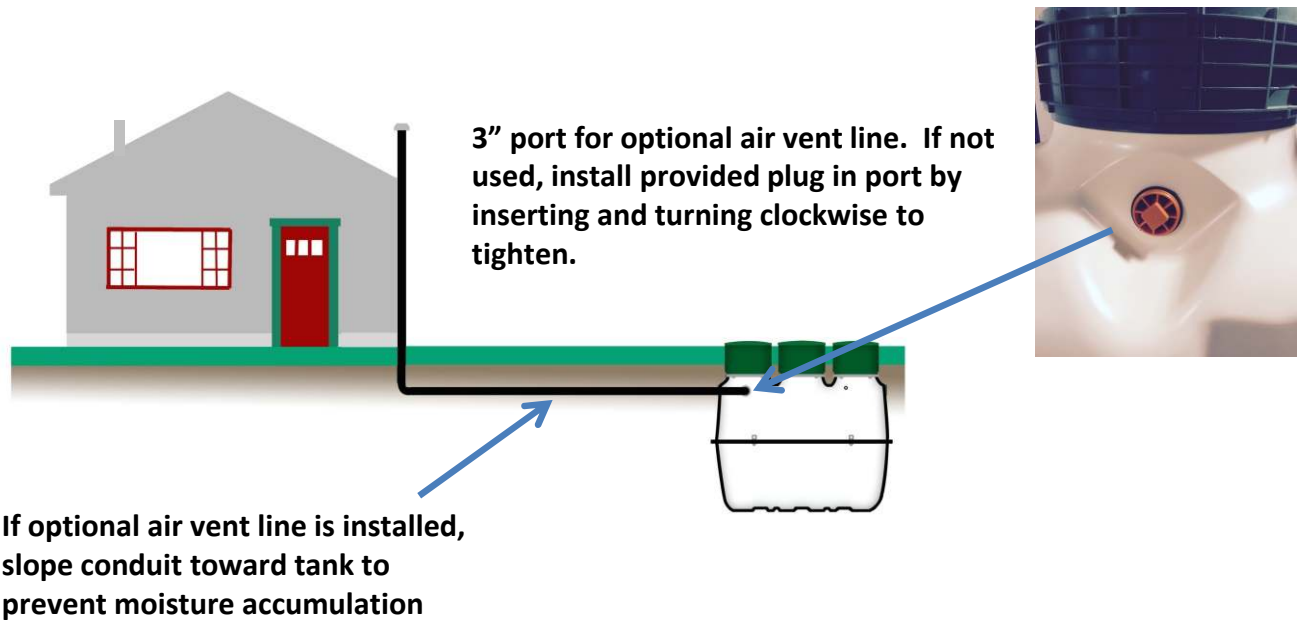

- ❑ **Step 12:** During final landscaping, seeding etc., be sure to pitch final grade away from covers to sweep surface water away from treatment tank.

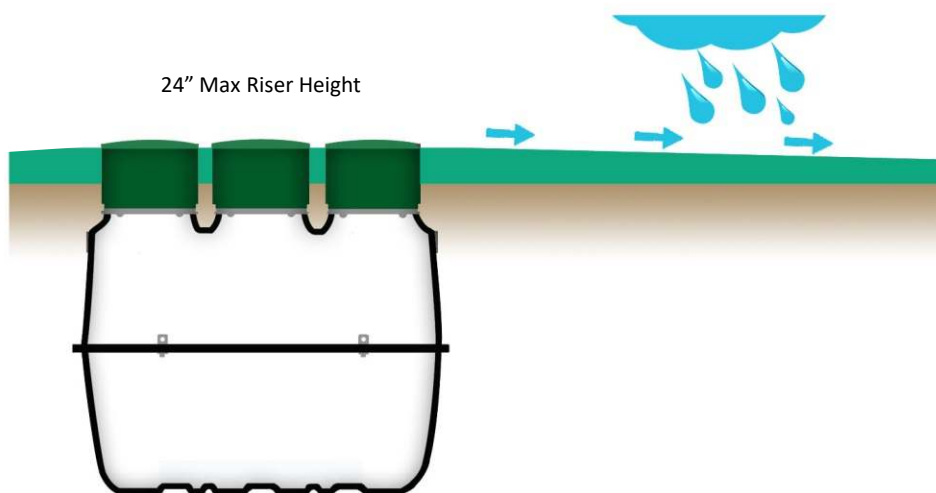

- ❑ **Step 13:** Fill out Warranty Activation Card (received with this Installation Manual) and return to FujiClean USA to activate system Warranty. If this card cannot be found, please contact FujiClean USA for Warranty activation. 207-406-2927.



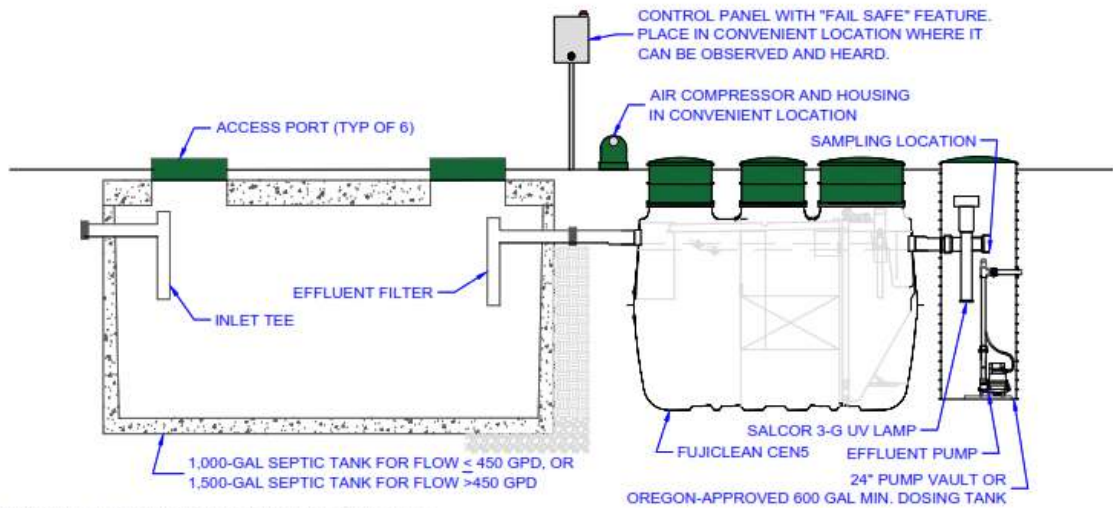
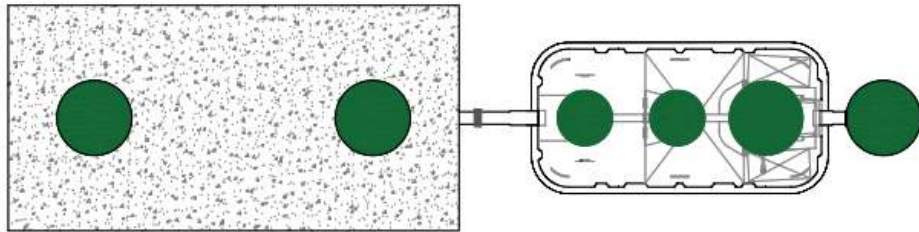

**NOTES:**

1. SEPTIC TANK AND PRODUCTS APPROVED BY OREGON DEQ.
2. SEPTIC TANK VOLUME AS REQ'D. BY OAR 340-071
3. PUMP VAULT DRAWDOWN IS 1.957 GAL/FT
4. ALL CONNECTIONS SHALL BE SEALED AND WATERTIGHT
5. ALL ELECTRICAL CONNECTIONS SHALL MEET APPLICABLE CODES
6. REVIEW THE FUJICLEAN INSTALLATION MANUAL FOR ADDITIONAL DETAILS
7. DESIGN AS SHOWN FOR TREATMENT STANDARD 2

**CEN5 WITH SEPTIC TANK AND EFFLUENT PUMPING**

SCALE:  
NONE  
DATE:  
11/01/2022  
DRAWN BY:  
BDB



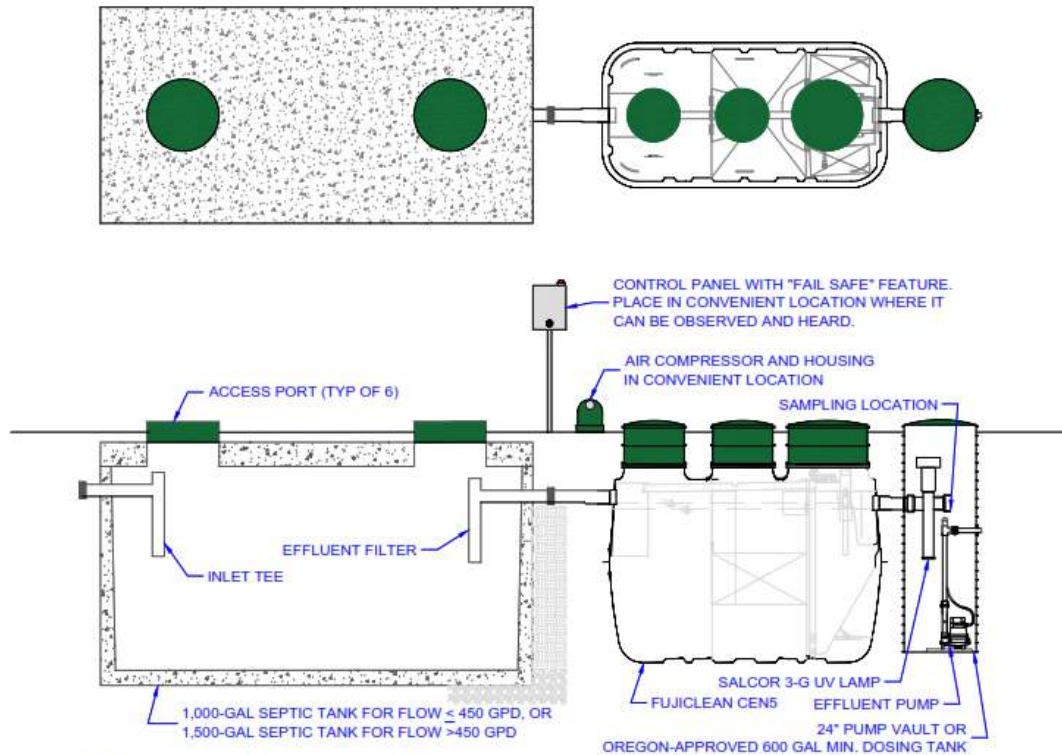

**NOTES:**

1. SEPTIC TANK AND PRODUCTS APPROVED BY OREGON DEQ.
2. SEPTIC TANK VOLUME AS REQ'D. BY OAR 340-071
3. PUMP VAULT DRAWDOWN IS 1.957 GAL/FT
4. ALL CONNECTIONS SHALL BE SEALED AND WATERTIGHT
5. ALL ELECTRICAL CONNECTIONS SHALL MEET APPLICABLE CODES
6. REVIEW THE FUJICLEAN INSTALLATION MANUAL FOR ADDITIONAL DETAILS
7. DESIGN AS SHOWN FOR TREATMENT STANDARD 2

**CEN5 WITH SEPTIC TANK AND EFFLUENT PUMPING**

SCALE:  
NONE

DATE:  
11/01/2022

DRAWN BY:  
BDB



❑ **Step 14: Finalize Controller Wiring.** Please have licensed electrician refer to wiring diagram in this manual and enclosed separately in alarm/control panel. Upgraded FujiClean controllers are available with options such as telecommunications or flow monitoring. Contact FujiClean USA for details.

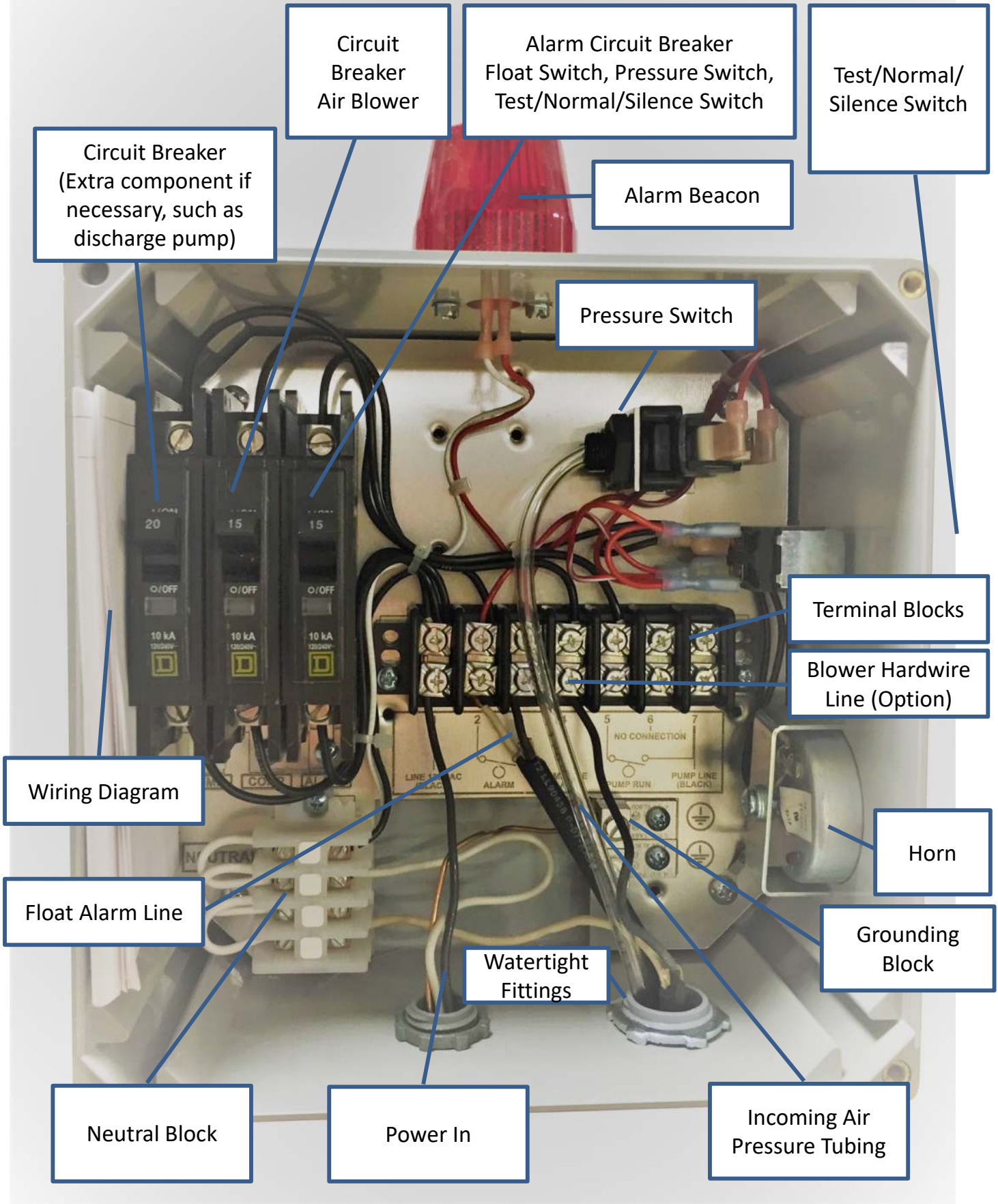

❑ **Step 15: Install and Wire “Fail-Safe” Control Panel. Upgraded FujiClean controllers are available with options such as telecommunications or flow monitoring. Contact FujiClean USA for details.**

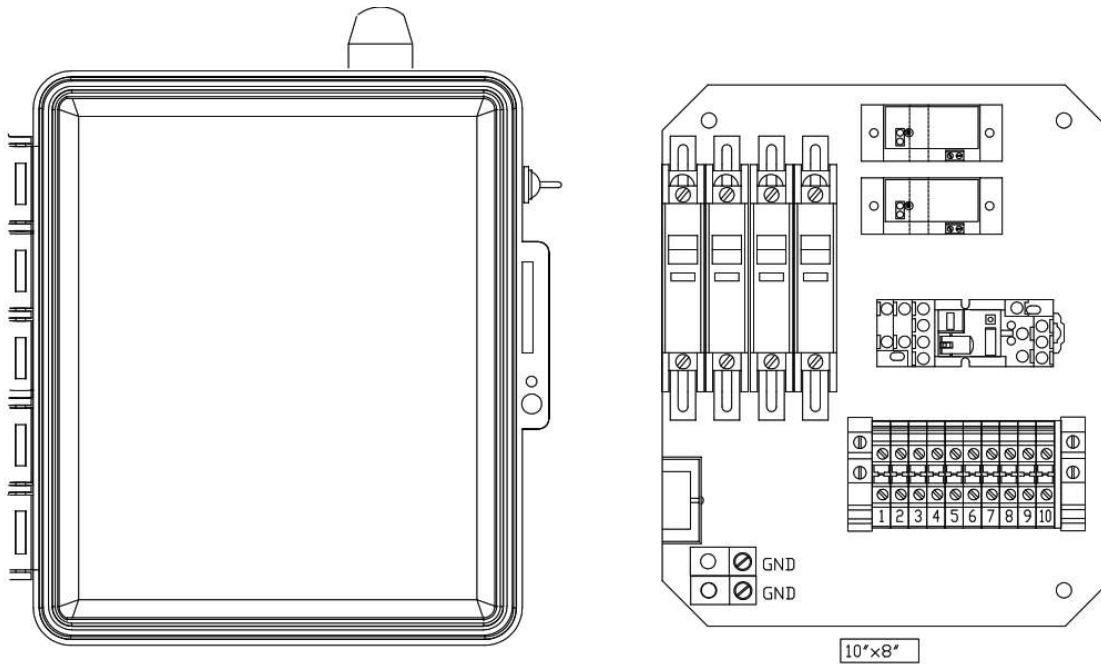

SJE RHOMBUS OPP22016

FUJI CLEAN OREGON “FAIL-SAFE” CONTROL PANEL OPP22016 Demand Dosing Configuration Alarm Condition Inactivates Pump	
Part Description	QTY
PLATE,BACK,10X8 GEN	1
LUG,GND,#4-14	2
BOOT,SW,TGL MOIST PROT	1
LBL,RH,UL/CUL 508	1
HORN ASSY,120V	1
BKR ASSY,1P QOU 240V 20ASQD	1
BKR ASSY,1P QOU 240V 15ASQD	3
SW,TGL,3/4HP 125/250V (T)NS	1
IND ASSY ALM LED SM RED 120V 100OHM	1
RELAY,120V 2P IND TEST RPM TELE	1
SKT,RELAY,2P RAIL MT RPM TELE	1
CTN, INS, 13.5 X 21.25	1
RELAY, CM, 0.5-50 AMP TRIP, MCS-111050	2
LBL, FUJI, NAMEPLATE GENERIIC 2.5X3.62	1
ENCL ASSY, N4X, 10X8X4 GRAY SJE	1



# Float Switch Information

The SJE Rhombus Signalmaster float switch is pre-mounted in FujiClean USA treatment systems. This information from SJE Rhombus is supplied for informed, proper handling during the installation process.

## SJE SIGNALMASTER®



- Mechanically activated.
- Control differential of 1.5 inches above or below horizontal.
- Not sensitive to rotation.
- Mounting options: mounting clamp or cable weight.

**Note:** All hose clamp components are made of 18-8 stainless steel material. See your SJE-Rhombus® supplier for replacements.

**Figure A**

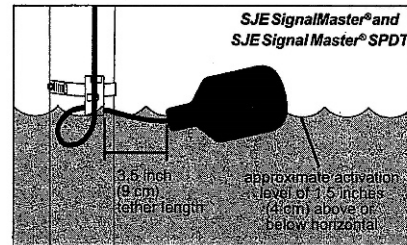

### ELECTRICAL SHOCK HAZARD

Disconnect power before installing or servicing this product. A qualified service person must install and service this product according to applicable electrical and plumbing codes.



### EXPLOSION OR FIRE HAZARD

Do not use this product with flammable liquids. Do not install in hazardous locations as defined by National Electric Code, ANSI/NFPA 70.

Failure to follow these precautions could result in serious injury or death. Replace product immediately if switch becomes damaged or severed. Keep these instructions with warranty after installation. This product must be installed in accordance with National Electric Code, ANSI/NFPA 70 so as to prevent moisture from entering or accumulating with in boxes, conduit bodies, fittings, float housing, or cable.

### PREVENTATIVE MAINTENANCE

- Periodically check the product. Check that the cable has not become worn or that the housing has not been damaged so as to impair the protection of the product. Replace the product immediately if any damage is found or suspected.
- Periodically check to see that the float is free to move and operate the switch.
- Use only SJE Rhombus replacement parts.
- The Sensor Float and Sensor Float Mini control switches contain mercury and MUST be recycle or disposed of according to local, state and federal codes.

## SJE-RHOMBUS® THREE-YEAR LIMITED WARRANTY

SJE-RHOMBUS® warrants to the original consumer that this product shall be free of manufacturing defects for three years after the date of consumer purchase. During that time period and subject to the conditions set forth below, SJE-RHOMBUS® will repair or replace, for the original consumer, any component which proves to be defective due to defective materials or workmanship of SJE-RHOMBUS®.

**THIS EXPRESS WARRANTY DOES NOT APPLY TO THE MOTOR START KIT COMPONENT. SJE-RHOMBUS® MAKES NO WARRANTIES OF ANY TYPE WITH RESPECT TO THE MOTOR START KIT.**

**ELECTRICAL WIRING AND SERVICING OF THIS PRODUCT MUST BE PERFORMED BY A LICENSED ELECTRICIAN.**

**THIS WARRANTY DOES NOT APPLY:** (A) to damage due to lightning or conditions beyond the control of SJE-RHOMBUS®; (B) to defects or malfunctions resulting from failure to properly install, operate or maintain the unit in accordance with printed instructions provided; (C) to failures resulting from abuse, misuse, accident, or negligence; (D) to units which are not installed in accordance with applicable local codes, ordinances, or accepted trade practices, and (E) to units repaired and/or modified without prior authorization from SJE-RHOMBUS®.

*Some states do not allow limitations on how long an implied warranty lasts, so the above limitation may not apply to you. Some states do not allow the exclusion or limitation of incidental or consequential damages, so the above limitation or exclusion may not apply to you. This warranty gives you specific legal rights, and you may also have other rights which vary from state to state.*

**TO OBTAIN WARRANTY SERVICE:** The consumer shall assume all responsibility and expense for removal, reinstallation, and freight. Any item to be repaired or replaced under this warranty must be returned to SJE-RHOMBUS®, or such place as designated by SJE-RHOMBUS®.

**ANY IMPLIED WARRANTIES OF MERCHANTABILITY OR FITNESS ARE LIMITED TO THE DURATION OF THIS WRITTEN WARRANTY. SJE-RHOMBUS® SHALL NOT, IN ANY MANNER, BE LIABLE FOR ANY INCIDENTAL OR CONSEQUENTIAL DAMAGES AS A RESULT OF A BREACH OF THIS WRITTEN WARRANTY OR ANY IMPLIED WARRANTY.**

## Start-Up Procedures

❑ **1. Outside Environment Check.**

The system is accessible and nothing inhibits access to maintenance.

- Surface water is draining away from risers and covers.
- No signs of physical damage to the treatment system, piping, alarms or components
- No unusual smells around the system.
- No unusually loud blower noise, such as rattling.

❑ **2. Blower Box Check.**

- Open the blower box, make sure that it is operating properly.
- Inspect all fittings and vents to ensure they are clean and dry and that blower is located so that it is protected from dust and particles, will remain dry and not be submerged.

❑ **3. Blower Operation and Blower Alarm Check.**

- Make sure the blower operates properly.
- Turn off the blower (unplug or turn off at alarm/control panel breaker switch) for few moments to check that the alarm is triggered.

*Open all access covers and secure the area around the access openings.*

❑ **4. Water Level is at LWL.**

- Check that tank has been filled to LWL mark in Chamber 1.



❑ **5. High Water Float Switch Check.**

- Check that the high water float switch is operating freely. Lift up the high water float switch to check that the alarm is triggered.
- (Note: Float should have 3.5” tether. Activation horizon is 1.5” above or below level horizon).

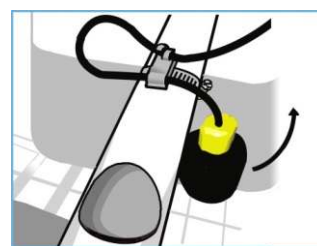

❑ **6. Set Recirculation Control Valve. (gray)**

The recirculation valve (gray) should be set to its default setting range according to the table below for ALL flows. At the discretion of the system’s start-up technician, within each default range, the valve shall be at the lower end for anticipated below average hydraulic flows and at the higher end for hydraulic flows that are anticipated to be above average.



Model	CE5	CE7	CE10
Default Valve Setting (%)	30% to 35%	25% to 30%	25% to 30%

**7. Check Recirculation Flow Rate.**

- Normal recirculation flow should be level with the top edge of the airlift pumpback line cut-out spilling into Chamber 1, the Sedimentation Chamber.



**8. Check/Set Aeration Balance Control Valve (blue).**

- The default, normal setting for the Aeration Control Valve is 50%.
- Visually observe the airflow rates on each side of the plant by checking to see if bubbles are evenly distributed on both sides of Chamber 3, The Aeration Chamber. If there is an obvious discrepancy in airflow between the two sides, adjust the Aeration Balance Control Valve so that the airflow is equal. Important!



**9. Check/Set Effluent Airlift Valve (white).** The Effluent Control Valve is initially set to 40% and there is typically no need for it to be adjusted under standard conditions.



**10. Check Effluent Airlift Pipe.**

Check the observation port in the airlift line to see if there is smooth water flow from the effluent airlift pump. If not, then check to be sure that there isn't a clog in the airlift pipe with a cleaning brush.



□ **11. Check Alarm/Control Panel**

- Check to be sure that Alarm/Control Panel is located in a secure, accessible location.
- Check fittings and wire connections are tight and secure. This includes connection between air hose and pressure switch.
- Important: Check to be sure that all panel penetrations are air and watertight. Be sure no gas from treatment system can leak into Alarm/Controller.
- Be sure electrical cord between blower and outlet is free and clear and no object is on cord.
- Check to be sure that panel is closed, secure and toggle switch is set to “Normal” setting.

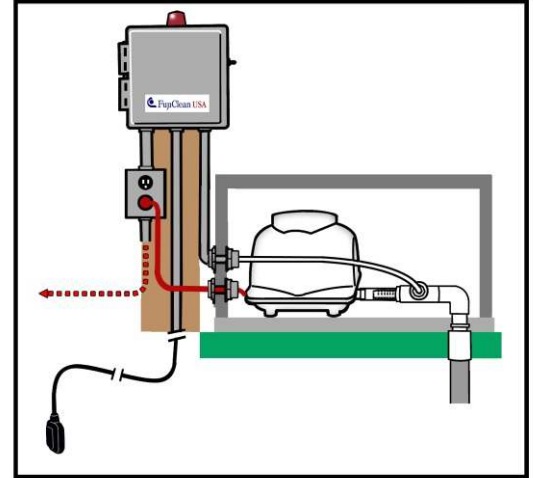

□ **12. Final Site Preparation**

- Close and secure all access covers.
- Close and secure blower cover.

□ **13. Owner Communication**

- Be sure that home/business owner has a copy of the FujiClean USA Owner’s Manual (with Warranty information included).
- Be sure that service provider contact information is affixed to Alarm/Control Panel as well as on Homeowner’s Manual.



Owner's Manual – Residential Systems



Intelligently Engineered Treatment Systems for Domestic Wastewater

Service Provider:	Model:
Name: _____	CE5 <input type="checkbox"/> CE7 <input type="checkbox"/> CE10
Company: _____	CE6 <input type="checkbox"/> CE7 <input type="checkbox"/> CE10
Address: _____	CE5 <input type="checkbox"/> CE7 <input type="checkbox"/> CE10
Telephone: _____	System Serial # _____
Email: _____	Blower Serial # _____



# TROUBLESHOOTING

## Air Blower

**What to observe**

**Status**

**How to solve the problem**

### Blower is not working

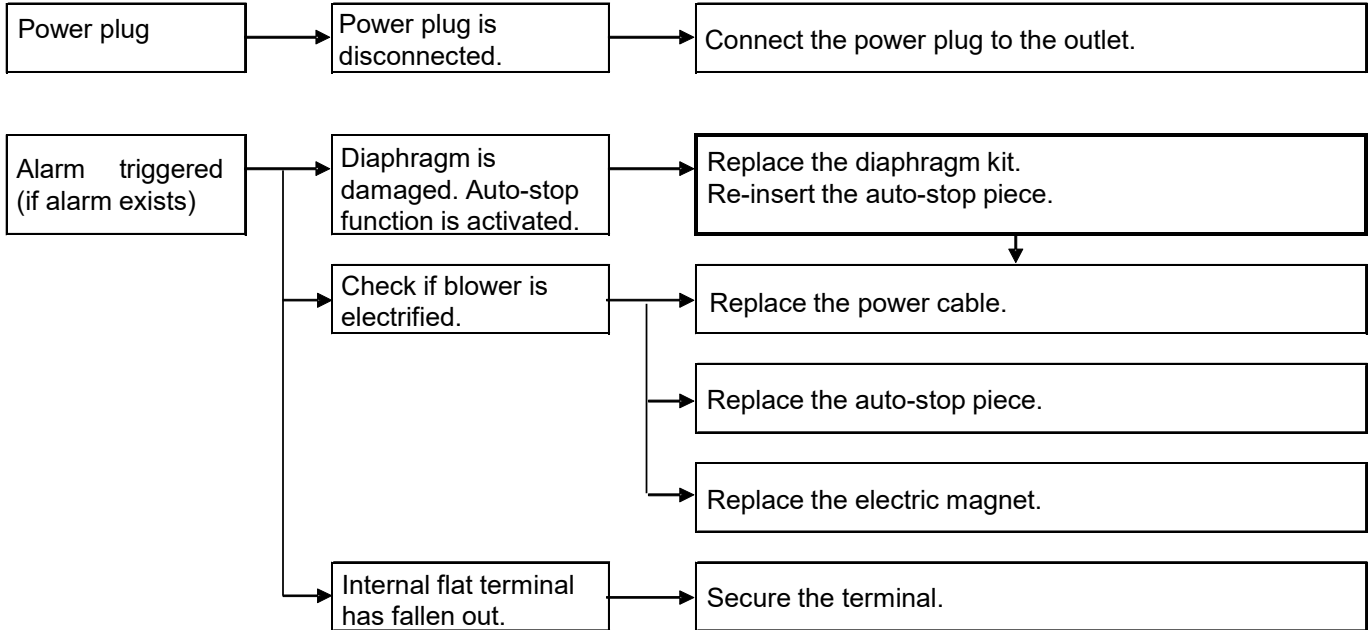

### Blower is making an abnormal or excessive operating noise.

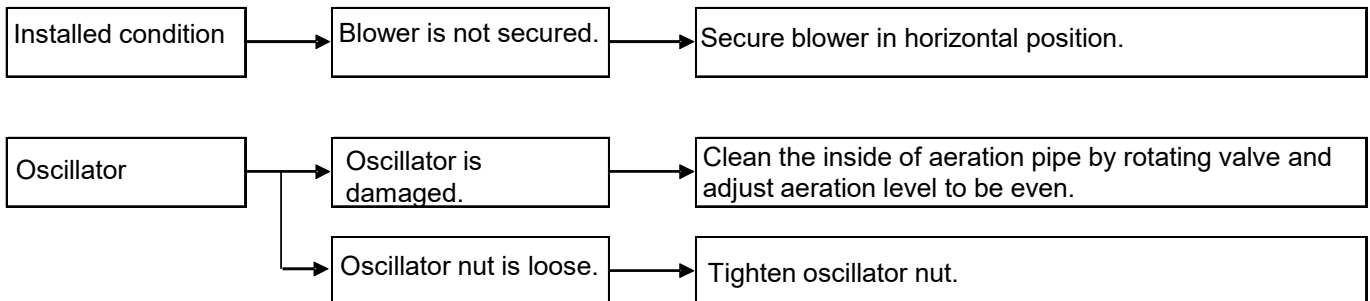

### Low air volume or misplaced air from aeration pipes (treatment plant)

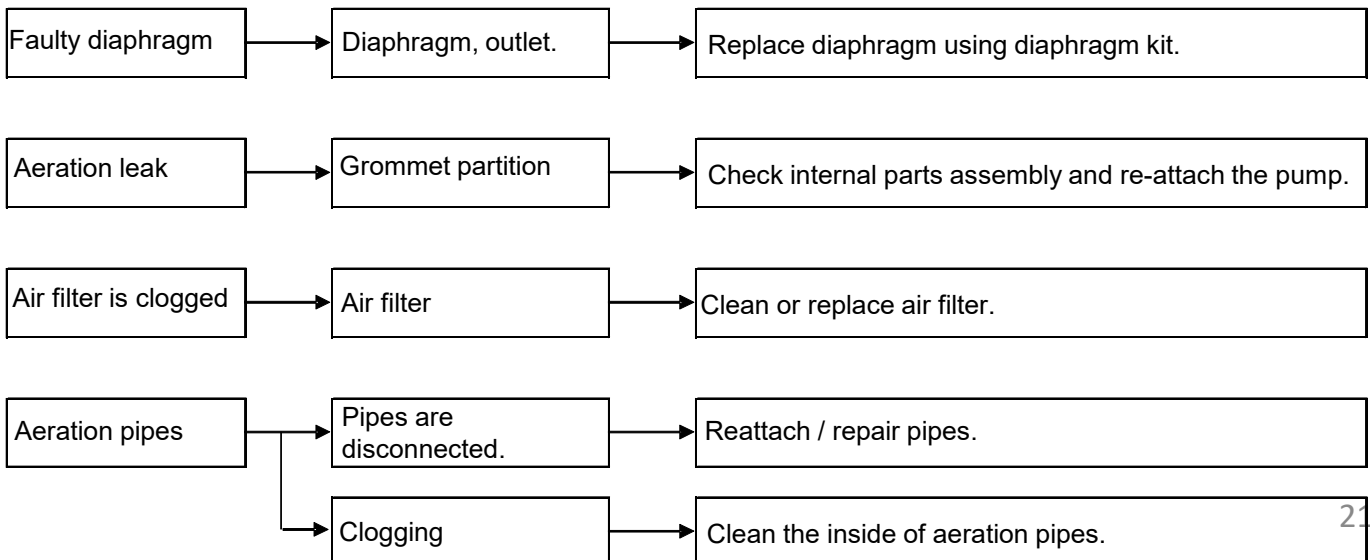



## **FujiClean USA Installation Procedure Checklist**

**Note:** Please consult Installation Manual for detailed instructions.

### **Unloading Instructions:**

- Upon delivery, inspect FujiClean tank, both outside and inside for possible damage incurred during transport. If you find damage, or have a question, please contact your distributor immediately.
- Step 1: Prepare excavation to be at least 1 to 2 feet larger than the FujiClean tank dimensions. Note: Riser height should not exceed 24".**
- Step 2: Prepare 4" - 6" bed of stone (¼" to ½"), level to within 1/8".**
- Step 3: Use 4-point lifting lugs. Carefully lower and set tank. Level to within 1/8-inch.**
- Step 4: If any part of the tank is below the estimated seasonal high water table, adequate tank uplift restraint measures should be taken. Please refer to Installation Manual for recommended options.**
- Step 5: Re-check that tank is level to 1/8-inch, (fore and aft as well as side to side) and then fill tank with fresh water to the low water line (marked inside tank). Start 24-hour water tightness test. (Please contact your distributor or FujiClean USA if water level has dropped after 24 hours).**
- Step 6: Backfill about ¾ way up tank in layered, compacted 6" lifts using peastone or equivalent material that form-fits into tank corrugations.**
- Step 7: Using supplied adaptors and fittings, attach air pipe fitting to tank and connect to ¾" or 1" conduit in prepared trench (min. 6" deep) to location of air blower. Please note: flexible irrigation line, 100 PSI Max, may also be used for the airline.**
- Step 8: Locate blower within 100-ft. of treatment tank with no more than 5 elbows. If site conditions prevent this configuration, please contact your distributor or FujiClean USA for technical assistance.**

#### **Air Blower shall be:**

- ✓ in as close proximity to control panel as possible
- ✓ on a solid (e.g. concrete) pad to minimize vibrations
- ✓ in a location above water level
- ✓ away from grease exhaust fans.
- ✓ away from bedroom windows and other locations where operational sounds (although minimal) may be a nuisance
- ✓ In a location that allows unencumbered access for inspection and maintenance activity
- ✓ with proper electrical grounding
- ✓ with wiring and electrical connections made by a licensed electrician.
- ✓ with no objects on top of electrical cord.
- ✓ in a well-ventilated space out of direct sunlight and protected from elements such as direct rain or snowfall.

## FujiClean USA Installation Procedure Checklist cont.

### Alarm Panel shall be:

- ✓ in a well ventilated area as dry and protected from elements as possible
- ✓ in as close of proximity to the FujiMAC blower as possible
- ✓ wired by qualified electrician
- ✓ in a location that allows unencumbered access for inspection and maintenance activity

- Step 9: Float switch electrical cord should exit riser wall through a male adaptor (caulked watertight to prevent septic gas leakage) or watertight fitting. An interior connection to direct burial cable is also an acceptable option.
- Step 10: Prepare Tank Inlet and Outlet for 4" Sched. 40 Inlet and Outlet Lines (secure with PVC cement).
- Step 11: In nearly all cases, the FujiClean system will vent properly through the house septic influent line. In cases where there is an influent pump, or in severe downdraft locations, a separate vent should be considered. If you do choose to install a vent, be sure that the vent slopes toward the tank so that any moisture accumulation drips back down toward the tank.
- Step 12: During final landscaping, seeding etc., be sure to pitch final grade away from covers to sweep surface water away from treatment tank.
- Step 13: Complete Warranty Card and send to FujiClean USA to activate Warranty.
- Step 14: Finalize Controller Wiring. Please have licensed electrician refer to wiring diagram (in Installer Manual and enclosed separately in alarm/control panel). Upgraded FujiClean USA controllers are available if telecommunications, elapsed time meter or other functions are required. Please contact FujiClean USA for details.
- Step 15: Follow start-up procedure detailed in Installation Manual:
  - 1. Outside Environment Check.
  - 2. Blower Box Check.
  - 3. Blower Operation and Blower Alarm Check
  - 4. Water Level is at LWL.
  - 5. High Water Float Switch Check.
  - 6. Set Recirculation Control Valve. (gray)
  - 7. Check Recirculation Flow Rate.
  - 8. Check/Set Aeration Balance Control Valve (blue).
  - 9. Check/Set Effluent Airlift Valve (white).
  - 10. Check Effluent Airlift Pipe.
  - 11. Check Alarm/Control Panel
  - 12. Final Site Preparation
  - 13. Owner Communication - Service Provider and Manual Delivery



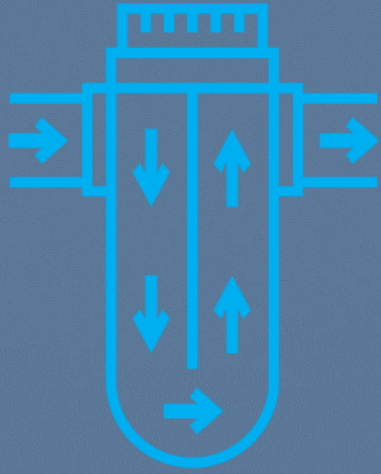

# LONGWAVE UV INC.



INSTALLATION/MAINTENANCE  
MANUAL





# Table of Contents

Click the title to take you to the page	Page Number	Links
<a href="#">Warnings</a>	3	
<a href="#">Parts List</a>	4	
<a href="#">Installation Steps</a>	5	
<a href="#">Caution</a>	10	
<a href="#">Installation options</a>	21	
<a href="#">Multi Array Units</a>	23	
<a href="#">Maintenance</a>	28	
<a href="#">Warranty</a>	37	<a href="#">Warranty Registration</a>
<a href="#">Website</a>		<a href="http://www.longwaveuv.com">www.longwaveuv.com</a>
<a href="#">Contact Us</a>		<a href="mailto:info@longwaveuv.com">info@longwaveuv.com</a>





# Warnings!

***A LICENSED ELECTRICIAN MUST INSTALL THIS UNIT!***

**WIRE ALL CIRCUITS WITH INSULATION RATED 600 VAC min.**

**THIS DEVICE PRODUCES POTENTIALLY HARMFUL UV LIGHT**

**ALWAYS PROTECT YOUR EYES AND SKIN FROM EXPOSURE TO UV LIGHT**

**MAKE SURE THE CONNECTOR MATES**

**COMPLETELY ONTO THE UV LAMP PINS**

**DISCONNECT POWER BEFORE REPLACING OR SERVICING THE 3G UNIT /LAMP**

**UV LAMP, QUARTZ TUBE AND TEFLON@ SHEATH ARE ALL FRAGILE**

**JUNCTION BOX SHOULD BE PROTECTED FROM FLOODING**

**DO NOT USE SILICONE OR PETROLEUM BASED LUBRICANTS ON THE GASKETS**



## Parts List

Disinfection chamber: 3-inch diameter ABS pipe with 4-inch inlet and outlet hubs-**1**

Disinfection sub-assembly consisting of an anodized aluminum frame supporting a --Teflon<sup>®</sup> sheath containing a pure fused quartz tube-**1**

Riser Pipe- 4-inch diameter ABS pipe-**1**

1-inch white PVC Lamp handle-**1**

Long life UV Lamp- Bubble wrapped and packed inside the PVC handle-**1**

Electrical Sub-Assembly Junction Box (rated NEMA 6P) - **1**

Alarm Board (pre-wired) - **1**

Electronic Ballast-**1**

Lamp Cord-**1**

4-inch Schedule 40 ABS pipe couplings-**2**

Watertight connection-**1**

Dielectric Grease-**1**

## Parts not Included

TEFLON@TAPE

ABS CEMENT

MULTI PURPOSE CEMENT

ISOPROPYL ALCOHOL

GLYCERIN

POWER AND ALARM WIRES

SILICONE ADHESIVE (R1V)

\*IF INSTALLING ABOVE GROUND IRRIGATION VALVE

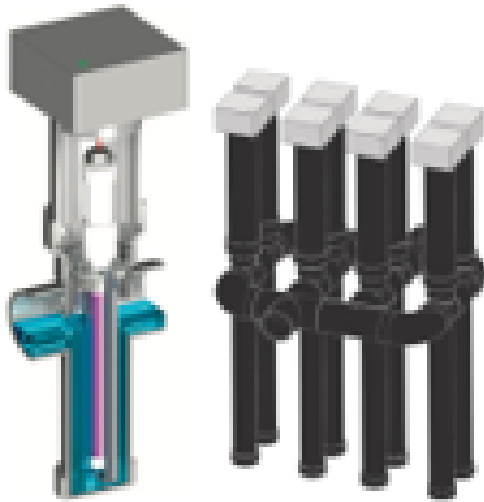

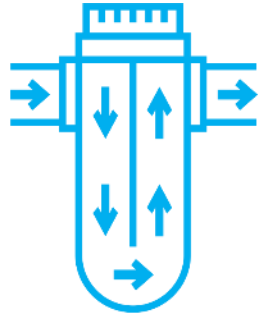

**LONGWAVE UV INC.**

## Installation Steps

### Salcor 3g Unit by Longwave UV, Inc.

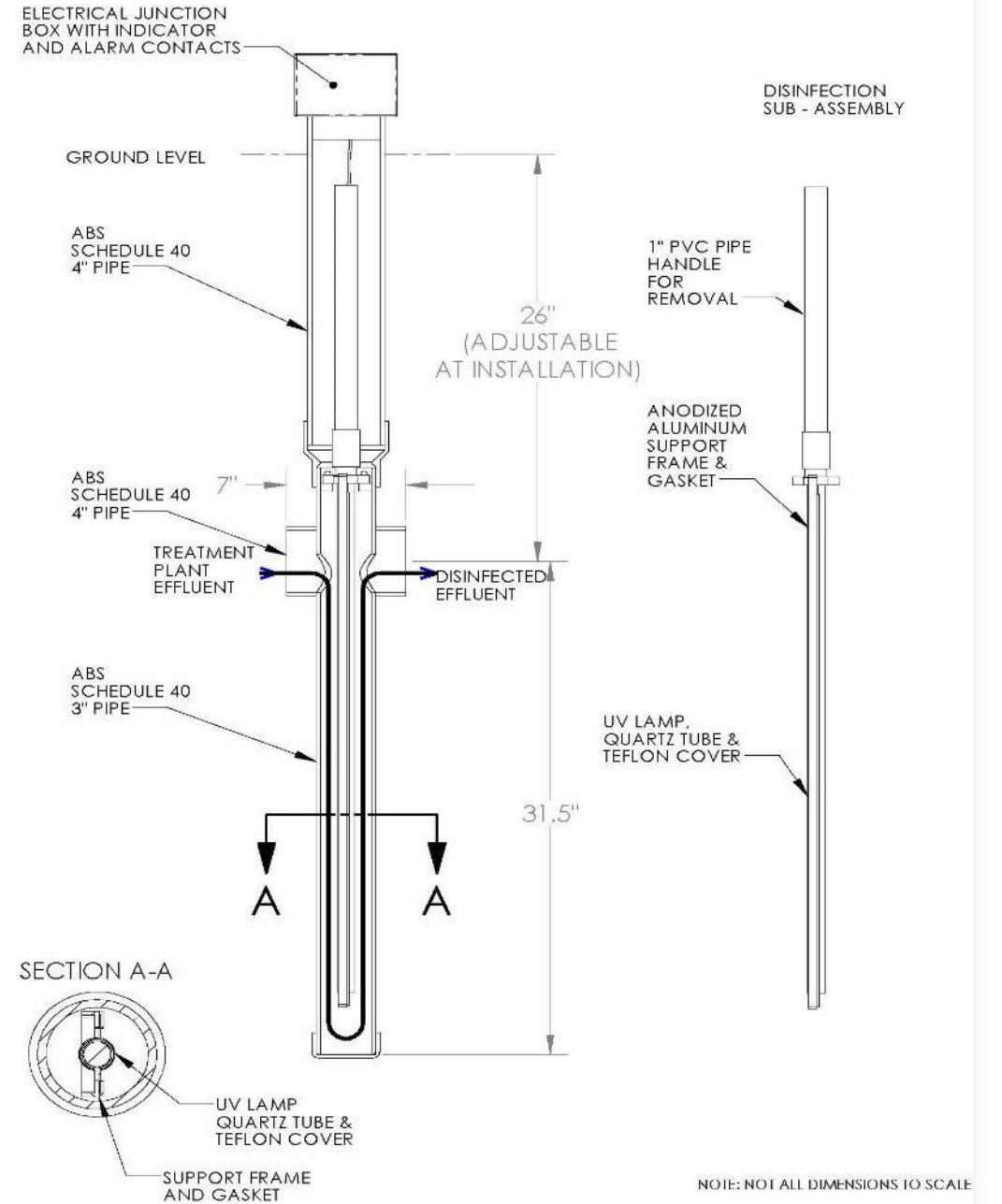



Install the 3-inch disinfection chamber in place at the site.

- a. Position the disinfection chamber in the ground or in the tank.
- b. Connect the hubs to the inlet and outlet pipes.



*White PVC Handle and  
4-inch Riser Pipe*

**Cut the 4-inch riser pipe to meet the job needs. The 1-inch lamp handle may be cut to length after cutting the riser pipe.**

**Use the 4-inch ABS inlet pipe connection to the pretreatment unit as a reference point.**

**The lamp handle upper end should be cut so it will be approximately 6 inches from the top of the riser pipe**



Bond the 4-inch riser pipe to the chamber sub-assembly.

d. Bond the second PVC white threaded female adapter to the top or plain end of the white PVC pipe handle



*Top End of PVC Handle with newly bonded adapter*

Carefully slide the lamp cord through the top of the white 1-inch PVC pipe handle. The lamp cord wire with the 4-pin lamp socket connector should extend out about 6 inches past the bottom end of the 1-inch white PVC handle which has a threaded female pipe adapter already bonded to it.



*Threaded Bottom End of PVC Handle*



*Lamp connector pins are not arranged in a square shape*

**Carefully connect the 4-pin socket connector of the lamp cord to the UV lamp pins. Note: the pins are not arranged in a square formation.**

**Apply Dielectric Grease to the inside of the boot.**

**Push the 4-pin socket onto the pins on the UV lamp end. Make sure that the 4-pin socket connector is fully connected onto the pins. The socket to lamp pins connection is electrically critical to maintain the proper operation of the lamp. It is extremely important that there is a fully mated complete connection between the socket and the UV lamp pins.**

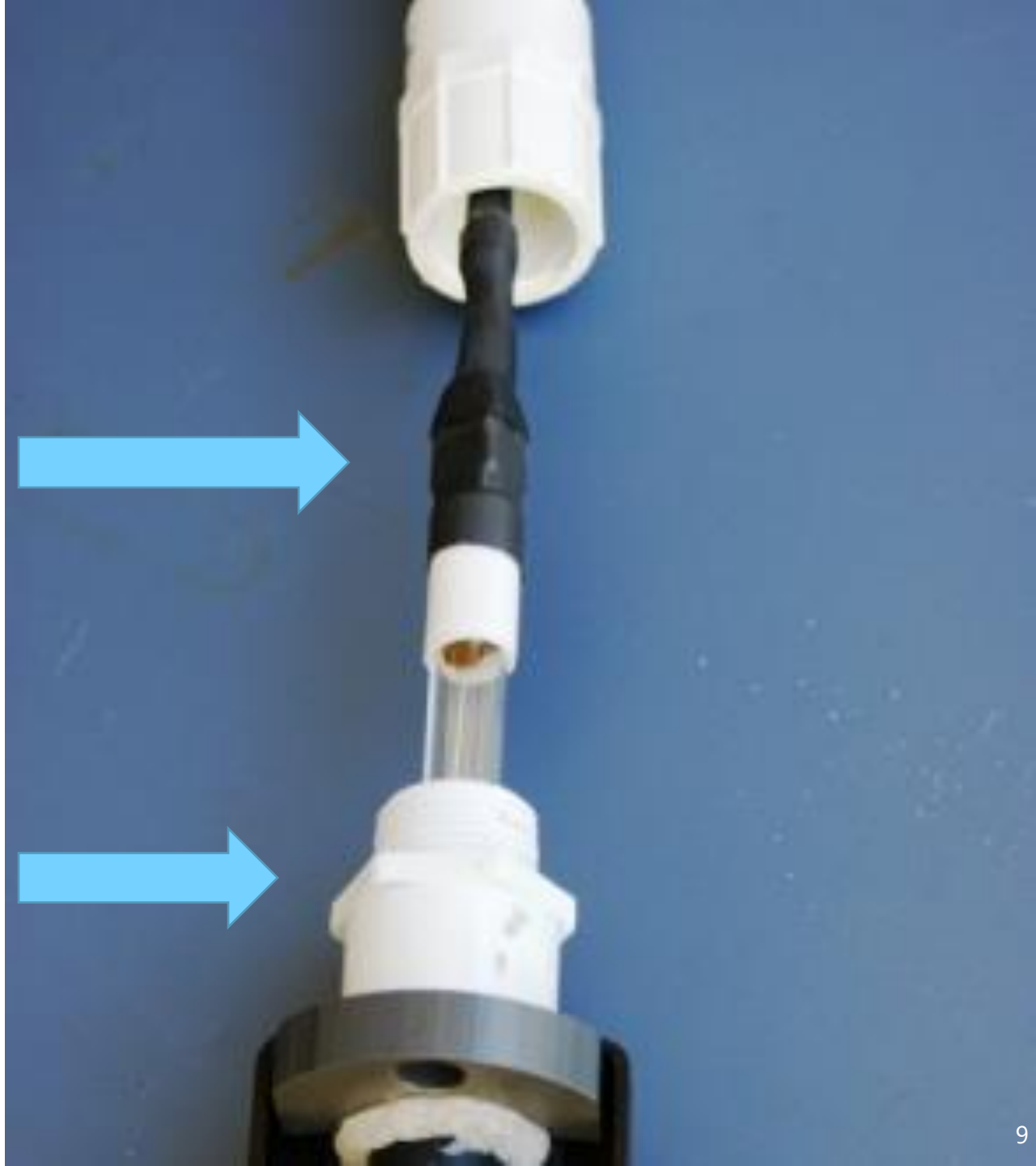



# CAUTION!!



The UV Lamp, the Quartz Tube, and the Teflon® Sheath Covering ARE ALL VERY FRAGILE, So Handle Them With Care. Carefully slide the UV lamp into the quartz tube in the frame assembly. Make sure that the UV lamp has **BOTTOMED OUT** in the Quartz Tube, that is, that the UV lamp is **FULLY SEATED** in the Quartz Tube. Do not force the UV lamp into the Quartz Tube, as UV Lamp may break the bottom of the Quartz Tube. Make sure that the UV Lamp is completely enclosed in the Quartz Tube.

# CAUTION

**Wrap both ends of the threaded white PVC 1-inch lamp handle pipe pieces with Teflon® tape. screw the threaded bottom end of the 1-inch lamp handle onto the top end of the aluminum frame assembly**

**and screw the black threaded reducer into the top end of the handle pipe. It is crucial that Teflon® tape is used to seal all of the threads to maintain the waterproof operation of the lamp.**

**Pull Any Extra Cord up Through the Gland Nut.**

**Tighten the gland nut to approximately 22 in/lb to make the UV lamp chamber watertight**

## DO NOT OVERTIGHTEN!!

*Black threaded reducer at the top of the lamp handle*

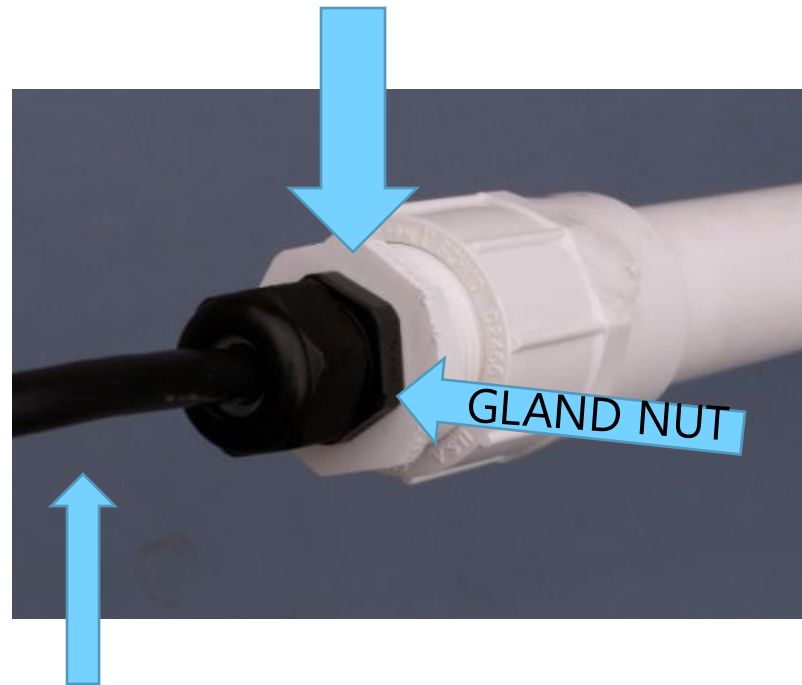

*EXTRA LAMP CORD*

*Top of the Aluminum Frame Assembly*



Anodized  
Frame  
Assembly

## Inspect the Teflon<sup>®</sup> sheath

**If necessary, use a clean soft cloth and isopropyl (rubbing) alcohol to clean and remove any fingerprints from the Teflon<sup>®</sup> sheath.**

**Lubricate the rubber gaskets with either water or glycerin.**



*PVC handle on the anodized aluminum frame assembly*



# Caution

**Gently insert the entire frame/handle assembly into the riser/chamber assembly using the white PVC handle. Make sure that the wide part of the sub-assembly is at right angles to the inlet and outlet pipes. The correct rotational orientation of the frame in the disinfection chamber is required for successful UV Unit operation. The frame must be at a right angle to the incoming effluent**

**Tuck the extra lamp cord wire into the top of the riser pipe.**

**Place the round coupling on the bottom of the junction box into the top of the 4-inch riser pipe and secure it with the setscrew.**



Install the Watertight Conduit connector to the side of the Junction Box and secure it with the nut on the inside. Use a little Silicone Adhesive Sealant, also called RTV, on the O-ring of the watertight conduit connector to assist in waterproofing

**Attention Installers!!**

**The LONGWAVE UV INC. Model 3G Unit requires a specific separate independent 10-15-amp circuit breaker on the main electrical panel. *The LONGWAVE UV INC. UV Unit circuit breaker should be separate from the circuit breakers for the pumps, etc.***

**No other electrical unit should be connected to the LONGWAVE UV INC. 3G Unit circuit breaker.**

**The UV Unit operates on 120 VAC single-phase (50 or 60 Hz) power and consumes 40 watts.**



*Watertight Conduit Connector Nut Inside of the Junction Box*

**Bring the power wires and alarm wires into the junction box via the waterproof conduit connection. Seal the outside of the flexible conduit pipe to the waterproof connector with *Silicone Adhesive Sealant*. The *installer* is responsible for ensuring that the external flexible wire conduit connection(s) containing the power and/or alarm wires to the junction box are **WATERTIGHT!!****

**GROUNDING  
POST**



max.

LISTED  
FLUORESCENT  
LAMP BALLAST



UR2

F1 2 A

T85



SPARE2



COM NO NC  
ALARM CONT S

10-30  
94V-0 CLD



**ALARM  
WIRE  
TERMINAL  
BLOCK**

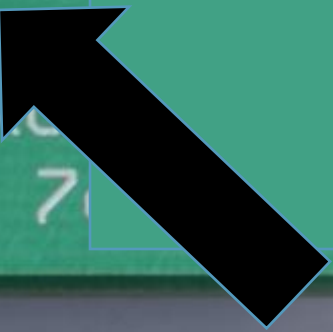

**POWER INLET  
TERMINAL BLOCK**





Attach the power and alarm wires to the appropriate terminal block connections on the Alarm Board. See [Figure 4](#) (Page 10). The alarm contacts are compatible with external alarm circuit units furnished by others that use either normally open (N/O) or normally closed (N/C) contacts. Note: N/O means the contacts are *OPEN* when there is *NO POWER* to the Alarm Board relay. The contacts are rated for up to 240 volts and up to 2 Amps. Select the common connection terminal screw and then use either the N/C or N/O connection terminal screw that complies with the external receiving alarm circuit requirement

**CAUTION**  
To reduce the risk of fire, replace only with the same type of 2A fuse



**Attach the lid to the junction box with 4 screws**

**Attach the lid to the junction box with 4 screws**

**Turn on the circuit breaker at the main electrical control panel. The Green Indicator Light on the junction box lid should now be shining, indicating that the 3G Unit is operating properly**



**YOUR  
INSTALLATION IS  
COMPLETE**

# TWO INSTALLATION OPTIONS

**IN GROUND INSTALLATION**

**IN TANK INSTALLATION**

---

*\*NOTE THE JUNCTION BOX CAN BE PLACED BELOW GRADE IN AN IRRIGATION VALVE BOX. THE BOX SHOULD BE PROTECTED FROM FLOODING.*



**Couple the 4-Inch inlet pipe to the exit pipe of the pretreatment**

**unit and couple the 4-inch outlet pipe to the drain field pipe.**

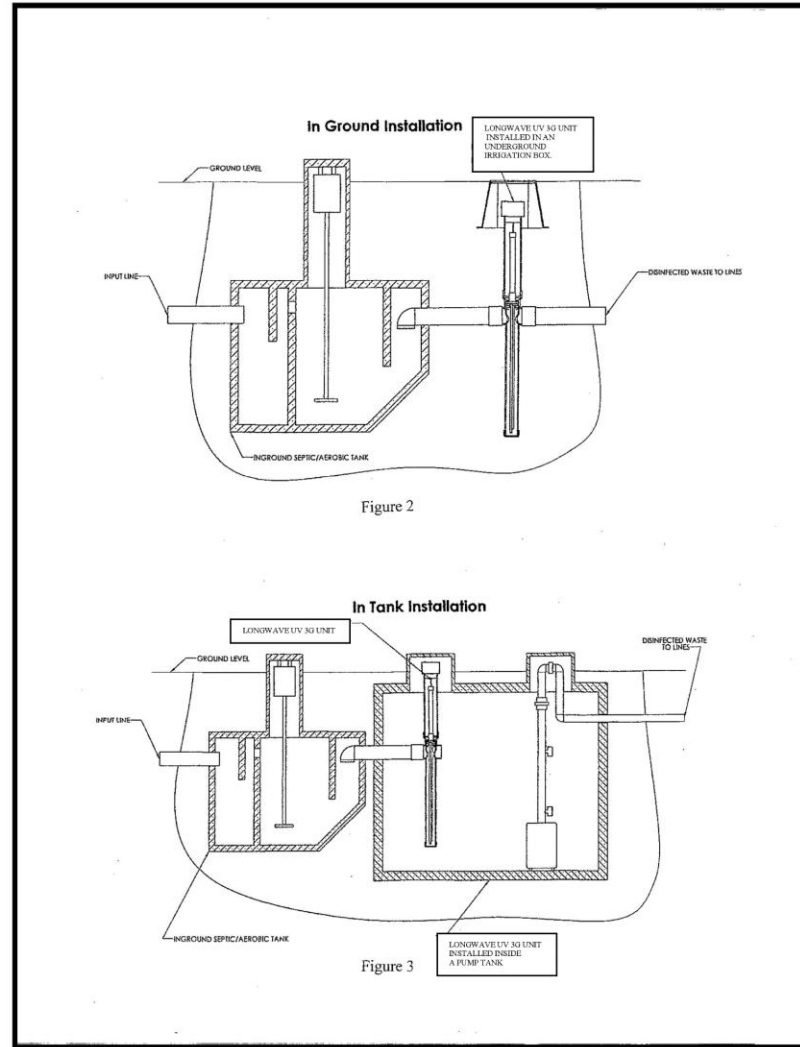

**COUPLE THE 3G UNIT INLET PIPE TO THE PRETREATMENT**

**UNIT EXIT PIPE AT THE ENTRANCE OF THE PUMP TANK.**



**Salcor 3G Unit can be stacked in multiple Arrays**

2 UNITS IN SERIES

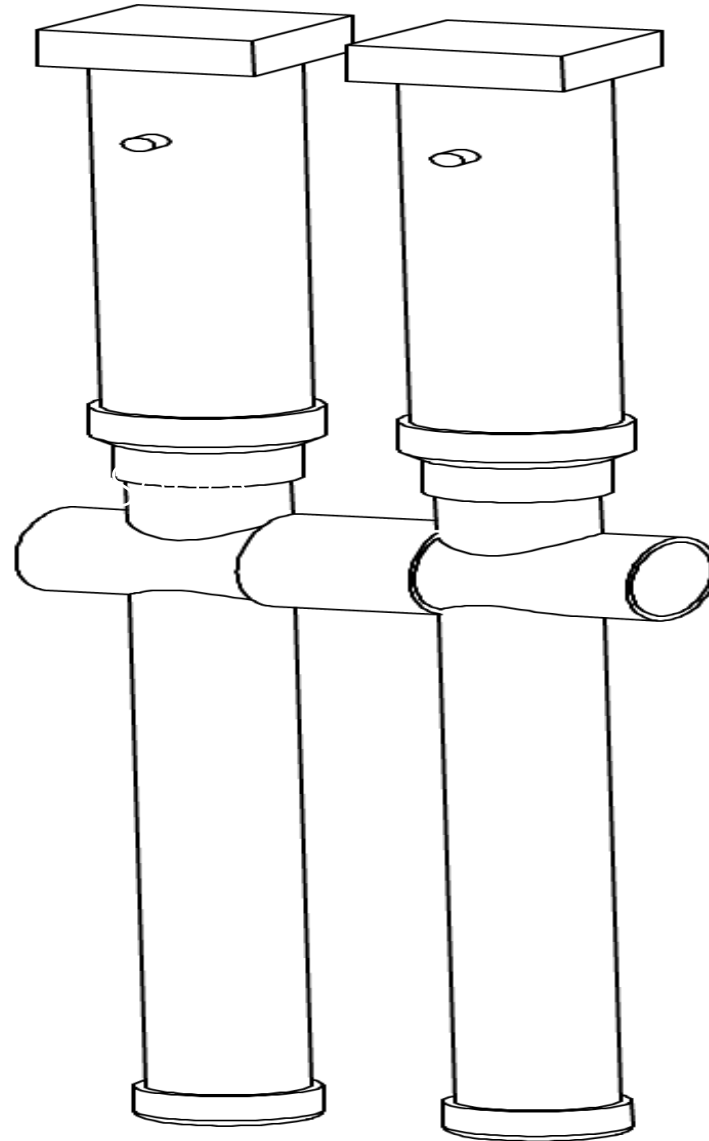
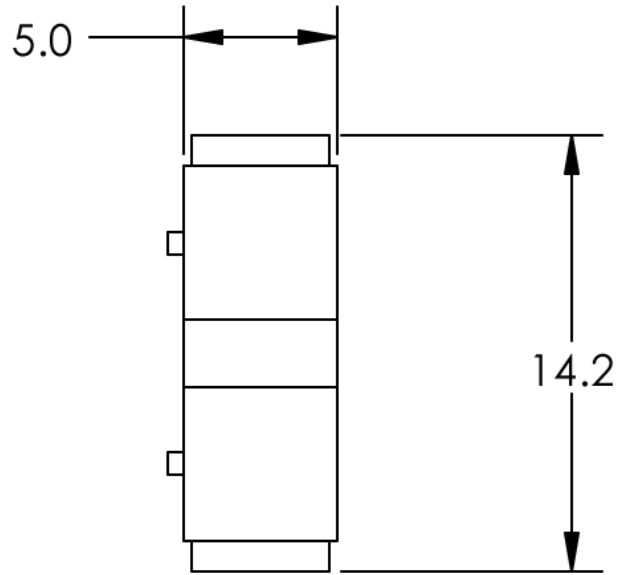

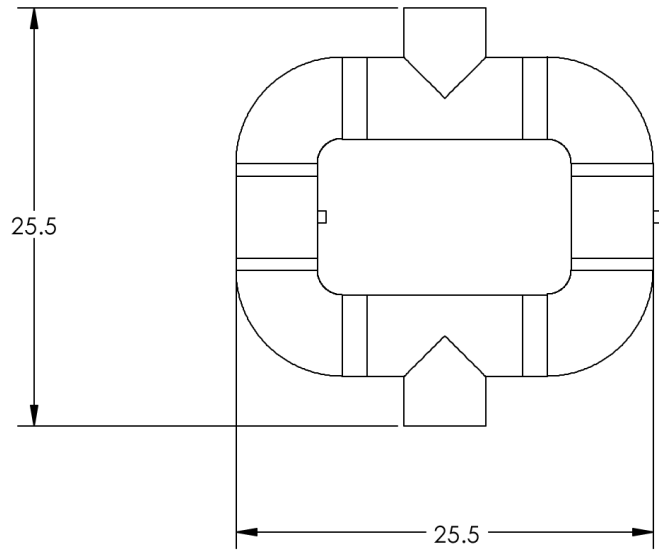

**2 UNITS IN PARALLEL**

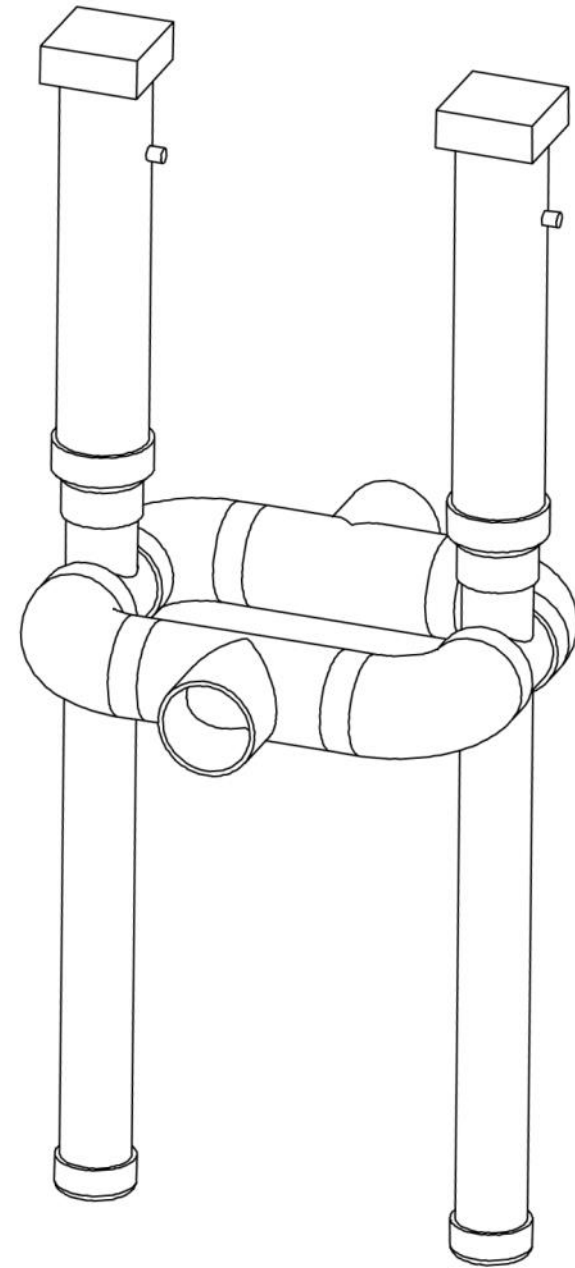



4 UNIT

## SERIES AND PARALLEL

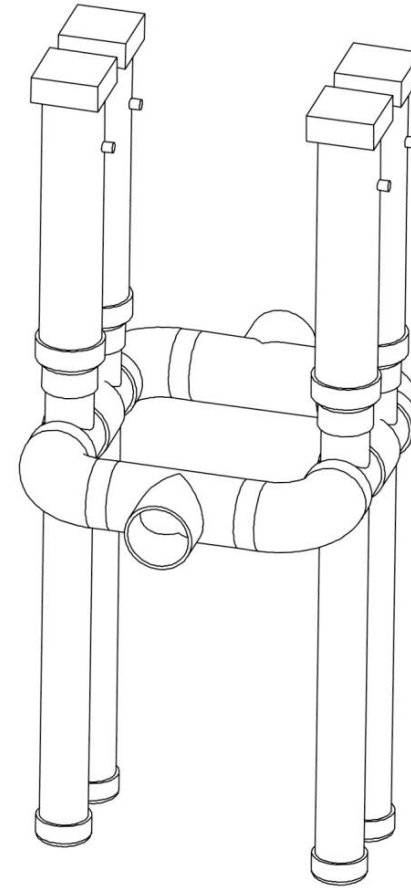
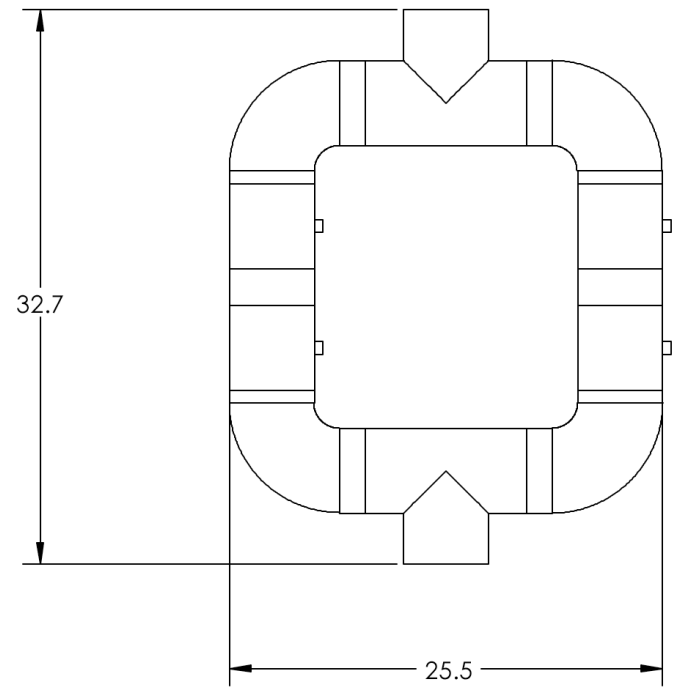

**12 UNITS IN PARALLEL**

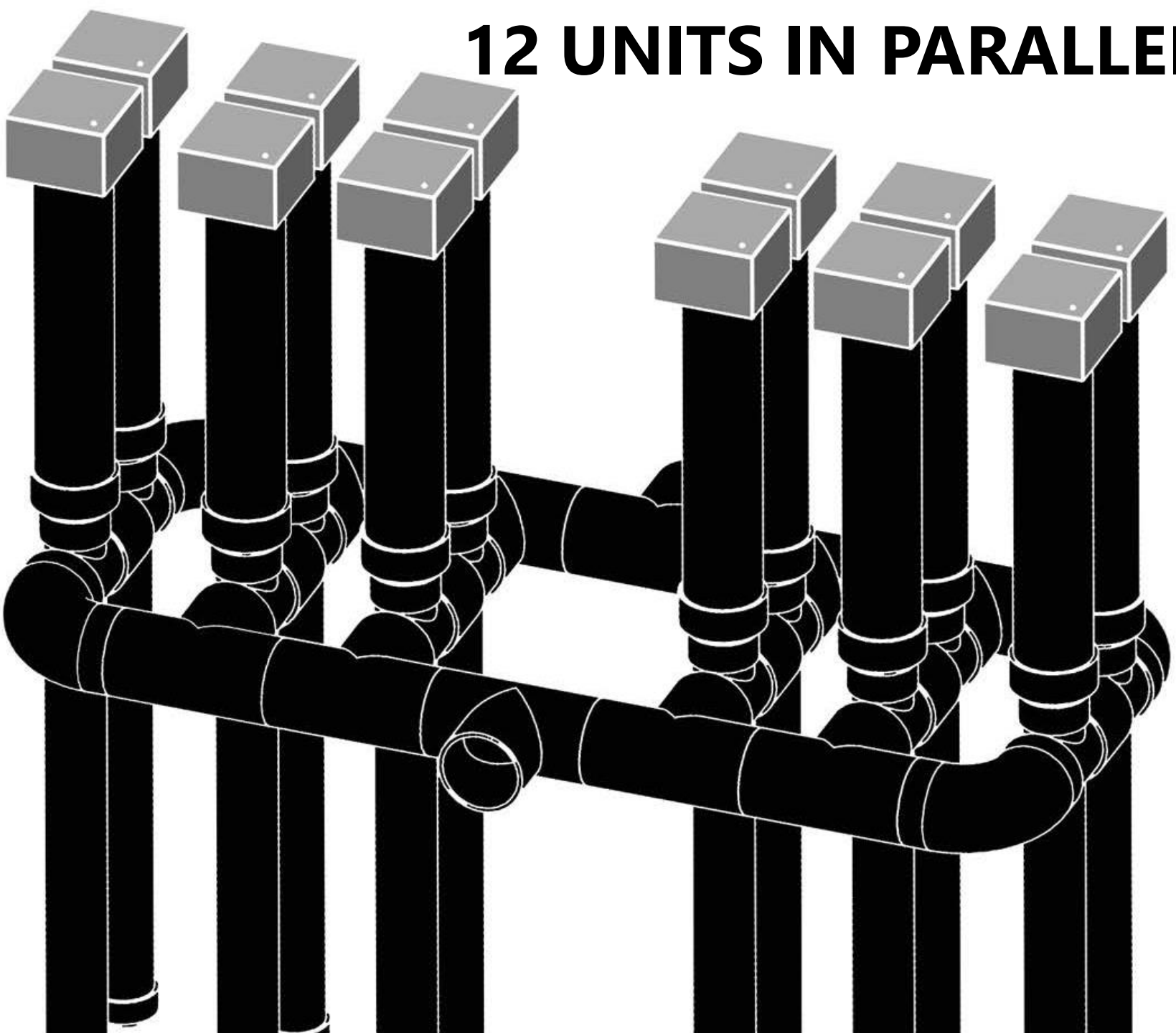
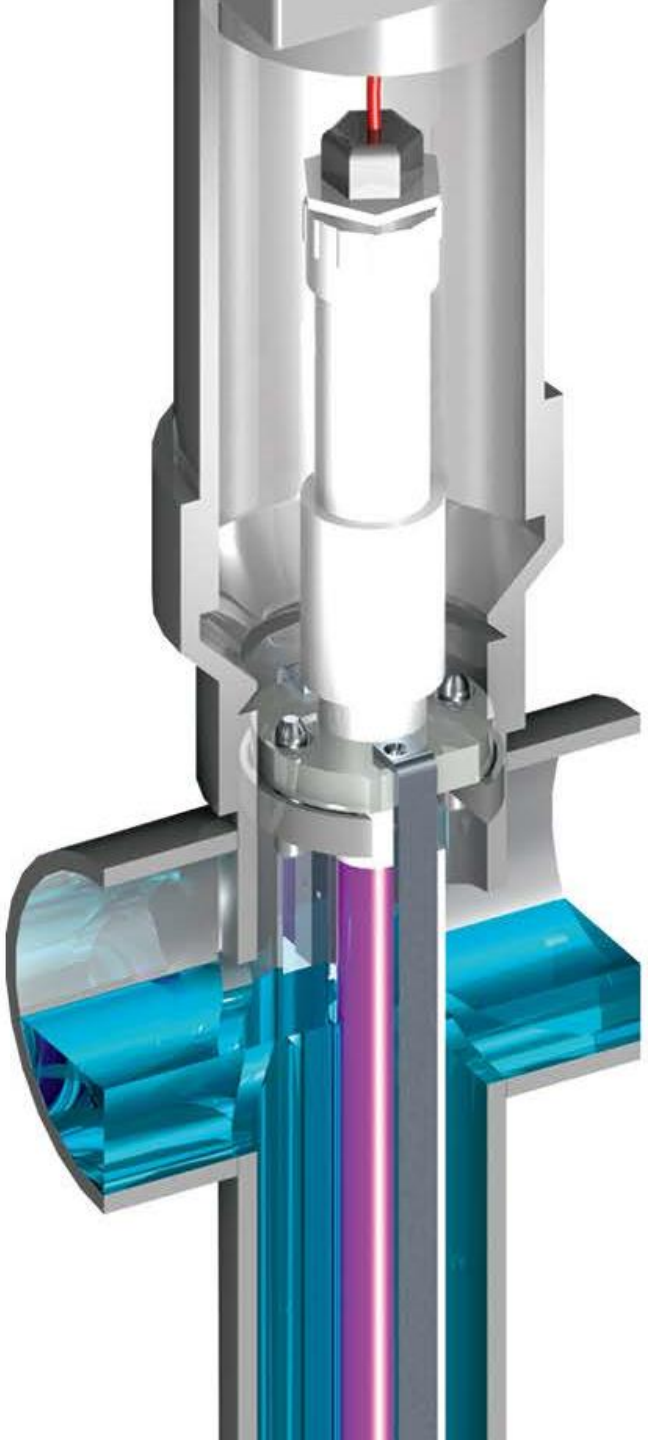



# Maintenance

## UV LAMP REPLACEMENT PROCEDURE

## STEP 1

Turn off the dedicated circuit breaker located on the main electrical control panel that supplies power to the UV Unit.

## STEP 2

- Remove the electrical junction box from the 4-inch riser pipe by loosening the junction box to riser pipe setscrew. Then carefully set the junction box aside.

## STEP 3

- Using the white PVC handle connected to the disinfection sub-assembly, lift the sub-assembly out of the disinfection chamber/riser pipe and set it aside.

## STEP 4

After pulling out the sub-assembly, check the disinfection chamber to make sure there is no mud, debris, or other flow-impeding non-liquid material present at the bottom of the disinfection chamber.

## STEP 5

- If there is non-liquid material present in the bottom of the disinfection chamber, use a shop vacuum cleaner to vacuum out the excess material. Do not let the material flow downstream

## STEP 6

- Loosen the lamp cord grip at the top of the white PVC handle so that the lamp cord can move through the cord grip and thus allow the handle to move away from the top of the aluminum frame assembly



## STEP 7

Unscrew the bottom threaded end of the 1-inch white PVC handle from the upper end of the aluminum frame assembly. Separate the handle from the assembly

## STEP 8

- Disconnect the four pin socket connector attaching the lamp cord to the UV lamp. Remove the old UV lamp

## STEP 9

- Use dielectric grease on the boot of the connector. Connect the 4-pin socket connector to the new lamp

## STEP 10

Lower the new UV lamp into the quartz tube of the UV sub-assembly, making sure it bottoms out in the quartz tube. Do not use force that would break the quartz tube.

## STEP 11

- Screw the bottom threaded end of the 1-inch lamp handle onto the upper end of the aluminum frame assembly. Use Teflon® tape to ensure a waterproof connection.

## STEP 12

- Using the white PVC handle, gently insert the entire frame/handle assembly into the riser/chamber assembly. Make sure that the wide part of the sub-assembly is at right angles to the inlet and outlet pipes

### STEP 13

Tuck the remaining lamp cord into the top of the riser pipe. Tighten all cord grips.

### STEP 14

- Put the junction box back onto the riser pipe. Tighten the setscrew.

### STEP 15

- Turn on the power to the UV Unit

STEP 16

Check the green indicator light on the lid of the junction box for proper operation

STEP 17

- If the green indicator light is on, the installation procedure is finished.

THE END

- FINISHED

**FRAGILE**

---

**HANDLE  
WITH CARE**

**TO CLEAN THE TEFLON □  
SHEATH AND DISINFECTION  
SUB-ASSEMBLY**



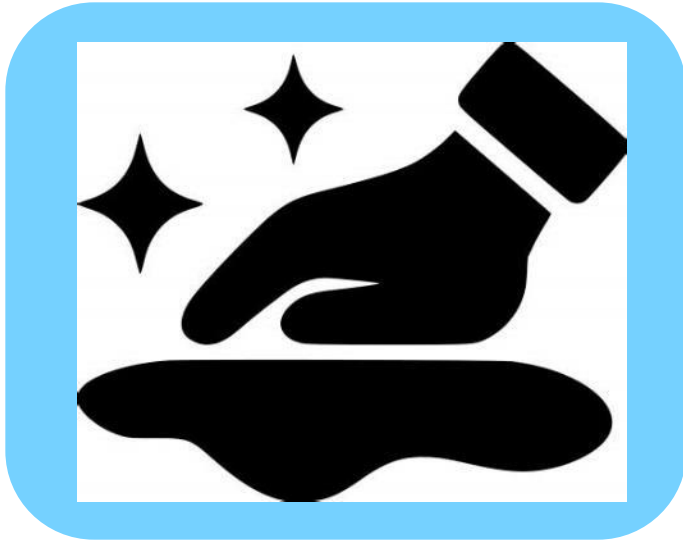

- Use a soft sponge and detergent to clean the surfaces, especially the Teflon® sheath. Be careful when cleaning the Teflon® sheath, as it is **Very Fragile**.



- Use a soft cloth with isopropyl alcohol to remove difficult stains such as fingerprints or other films from the Teflon® sheath.



## 2 Year Limited Warranty

This warranty is given by LONGWAVE UV INC. for the benefit of the first purchaser of the product for which this warranty applies. The warranty applies only to those parts which are manufactured and delivered by LONGWAVE UV INC.

The warranty is that the parts manufactured and delivered by LONGWAVE UV INC. will be free from defects in the material or workmanship under normal use and service according to the Installation and Operating Instructions for the time specified below.

In the event of a failure of a part due to such a covered defect, LONGWAVE UV INC. will repair or replace, at its option, the defective part at its factory located at 447 Ammunition Road, Suite E, Fallbrook, CA 92028. At the option of [LONGWAVE UV INC.](#), repairs or replacement may be made at the site of equipment installation.

The part must be returned to the factory at the expense of the person claiming the benefit of the warranty unless LONGWAVE UV INC. elects to repair or replace the defective part at the installed site.

The warranty shall be for a period of twenty four (24) months after the date of delivery of the product, or the specified service life of the product, whichever period is the shortest. All products for which warranty claims are filed must be returned as provided above to the factory within thirty (30) days from the date of the claimed malfunction in order for this warranty to be effective. The only entity authorized to do any warranty repairs is LONGWAVE UV INC.

The repairs or replacement by LONGWAVE UV INC. will be accomplished within thirty (30) days from receipt of the defective parts at the factory.

This warranty is expressed in lieu of all other warranties, expressed or implied, including the implied warranty of fitness for a particular purpose, and of all other obligations or liabilities on the part of [LONGWAVE UV INC.](#), and it neither assumes nor authorizes any other persons to assume for LONGWAVE UV INC. any other liabilities in connection with the sale of the products.

This warranty does not cover parts or products made by others, or products or any part thereof which have been repaired or altered, except by [LONGWAVE UV INC.](#), which shall have been subjected to misuses, negligence, or accident.

LONGWAVE UV INC. shall not be liable for damage or delay suffered by the purchaser regardless of whether such damages are general, special, or consequential in nature whether caused by defective material or workmanship, or otherwise, or whether caused by LONGWAVE UV INC. negligence, regardless of degree.

**Thank you for  
choosing Longwave  
UV, Inc.**

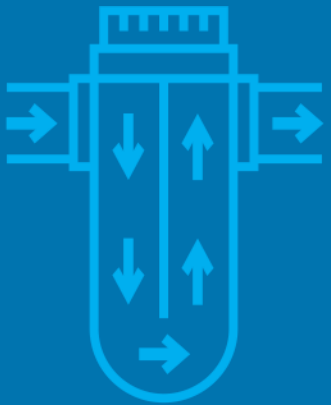

**LONGWAVE UV INC.**

