

CHAPTER 24 FUEL GAS

SECTION G2401 (101) GENERAL

G2401.1 ~~(101.2)~~ Application. This chapter covers those fuel gas *pipng systems*, fuel-gas *appliances* and related accessories, *venting systems* and *combustion air* configurations most commonly encountered in the construction of one- and two-family dwellings and structures regulated by this *code*.

Coverage of *pipng systems* shall extend from the *point of delivery* to the outlet of the *appliance* shutoff valves (see definition of “*Point of delivery*”). *Pipng systems* requirements shall include design, materials, components, fabrication, assembly, installation, testing, and inspection, ~~operation and maintenance~~. Requirements for gas *appliances* and related accessories shall include installation, combustion and ventilation air and venting and connections to *pipng systems*.

The omission from this chapter of any material or method of installation provided for in the ~~*International Fuel Gas Mechanical Code*~~ shall not be construed as prohibiting the use of such material or method of installation. Fuel-gas *pipng systems*, fuel-gas *appliances* and related accessories, *venting systems* and *combustion air* configurations not specifically covered in these chapters shall comply with the applicable provisions of the ~~*International Fuel Gas Mechanical Code*~~.

Gaseous hydrogen systems shall be regulated by ~~Chapter 7 Appendix C~~ of the ~~*International Fuel Gas Mechanical Code*~~.

This chapter shall not apply to the following:

1. Liquefied natural gas (LNG) installations.
2. Temporary ~~LP-fuel-gas~~ *pipng* for buildings under construction or renovation that is not to become part of the permanent *pipng system*.
3. Except as provided in Section G2412.1.1, gas *pipng*, meters, gas pressure regulators, and other appurtenances used by the serving gas supplier in the distribution of gas, other than undiluted LP-gas.
4. Portable ~~LP-fuel-gas~~ *appliances* and *equipment* of all types that is not connected to a fixed fuel *pipng system*.
5. Portable fuel cell *appliances* that are neither connected to a fixed *pipng system* nor interconnected to a power grid.
6. Installation of hydrogen gas, LP-gas and compressed natural gas (CNG) systems on vehicles.

G2401.2 Authority to render gas service.

G2401.2.1 Turn on authority. A serving gas supplier or person furnishing gas shall not turn on, or cause to be turned on, fuel gas or gas meters until the approval of the rough piping inspection is in compliance with Section G2417.1.1.1.

G2401.2.2 Temporary gas service. Temporary fuel gas service shall be permitted upon approval of the *municipality*.

SECTION G2402 ~~(201)~~ GENERAL

G2402.1 ~~(201.1)~~ Scope. Unless otherwise expressly stated, the following words and terms shall, for the purposes of this chapter, have the meanings indicated in this chapter.

G2402.2 ~~(201.2)~~ Interchangeability. Words used in the present tense include the future; words in the masculine gender include the feminine and neuter; the singular number includes the plural and the plural, the singular.

G2402.3 ~~(201.3)~~ Terms defined in other codes. Where terms are not defined in this code and are defined in the ~~*International Electrical Code, Building Code, International Fire Code, International Mechanical Code, International Fuel Gas Code or International Plumbing Code*~~, such terms shall have meanings ascribed to them as in those *codes*.

SECTION G2403 ~~(202)~~ GENERAL DEFINITIONS

~~**ACCESS (TO).** That which enables a device, appliance or equipment to be reached by ready access or by a means that first requires the removal or movement of a panel, door or similar obstruction (see also “Ready access”).~~

~~**AIR, EXHAUST.** Air being removed from any space or piece of equipment or appliance and conveyed directly to the atmosphere by means of openings or ducts.~~

~~**AIR, MAKEUP.** Any combination of outdoor and transfer air intended to replace exhaust air and exfiltration.~~

AIR CONDITIONER, GAS-FIRED. A gas-burning, automatically operated *appliance* for supplying cooled air, dehumidified air, or both, or chilled liquid.

AIR CONDITIONING. The treatment of air so as to control simultaneously the temperature, humidity, cleanness and distribution of the air to meet the requirements of a conditioned space.

AIR-HANDLING UNIT. A blower or fan used for the purpose of distributing supply air to a room, space or area.

~~**ALTERATION.** A change in a system that involves an extension, addition or change to the arrangement, type or purpose of the original installation.~~

ANODELESS RISER. A transition assembly in which plastic *pipng* is installed and terminated above ground outside of a building.

APPLIANCE. Any apparatus or device that utilizes a fuel or a raw material as a fuel to produce light, heat, power, refrigeration or air conditioning. Also, an apparatus that compresses fuel gases.

APPLIANCE, AUTOMATICALLY CONTROLLED. Appliances equipped with an automatic *burner* ignition and safety shutoff device and other automatic devices, that accomplish complete turn-on and shutoff of the gas to the *main burner* or *burners*, and graduate the gas supply to the *burner* or *burners*, but do not affect complete shutoff of the gas.

APPLIANCE, FAN-ASSISTED COMBUSTION. An *appliance* equipped with an integral mechanical means to either draw or force products of combustion through the combustion chamber or heat exchanger.

APPLIANCE, UNVENTED. An *appliance* designed or installed in such a manner that the products of combustion are not conveyed by a vent or *chimney* directly to the outside atmosphere.

APPLIANCE, VENTED. An *appliance* designed and installed in such a manner that all of the products of combustion are conveyed directly from the *appliance* to the outside atmosphere through an *approved chimney* or vent system.

~~**APPROVED.** Acceptable to the code official.~~

~~**APPROVED AGENCY.** An established and recognized agency that is regularly engaged in conducting tests, furnishing inspection services or furnishing certification, where such agency has been approved by the code official.~~

ATMOSPHERIC PRESSURE. The pressure of the weight of air and water vapor on the surface of the earth, approximately 14.7 pounds per square inch (psia) (101 kPa absolute) at sea level.

AUTOMATIC IGNITION. Ignition of gas at the *burner(s)* when the gas controlling device is turned on, including reignition if the flames on the *burner(s)* have been extinguished by means other than by the closing of the gas controlling device.

BAROMETRIC DRAFT REGULATOR. A balanced *damper* device attached to a *chimney*, vent *connector*, breeching or flue gas manifold to protect combustion *appliances* by controlling *chimney draft*. A double-acting *barometric draft regulator* is one whose balancing *damper* is free to move in either direction to protect combustion *appliances* from both excessive *draft* and backdraft.

~~**BOILER, LOW-PRESSURE.** A self-contained *appliance* for supplying steam or hot water.~~

~~**Hot water heating boiler.** A boiler in which no steam is generated, from which hot water is circulated for heating purposes and then returned to the boiler, and that operates at water pressures not exceeding 160 pounds per square inch gauge (psig) (1100 kPa gauge) and at water temperatures not exceeding 250°F (121°C) at or near the boiler outlet.~~

~~**Hot water supply boiler.** A boiler, completely filled with water, which furnishes hot water to be used externally to itself, and that operates at water pressures not exceeding 160 psig (1100 kPa gauge) and at water temperatures not exceeding 250°F (121°C) at or near the boiler outlet.~~

~~**Steam heating boiler.** A boiler in which steam is generated and that operates at a steam pressure not exceeding 15 psig (100 kPa gauge).~~

BONDING JUMPER. A conductor installed to electrically connect metallic gas *pipng* to the grounding electrode system.

BRAZING. A metal-joining process wherein coalescence is produced by the use of a nonferrous filler metal having a melting point above 1,000°F (538°C), but lower than that of the base metal being joined. The filler material is distributed between the closely fitted surfaces of the joint by capillary action.

BTU. Abbreviation for British thermal unit, which is the quantity of heat required to raise the temperature of 1 pound (454 g) of water 1°F (0.56°C) (1 *Btu* = 1055 J).

BURNER. A device for the final conveyance of the gas, or a mixture of gas and air, to the combustion zone.

Induced-draft. A *burner* that depends on *draft* induced by a fan that is an integral part of the *appliance* and is located downstream from the *burner*.

Power. A *burner* in which gas, air or both are supplied at pressures exceeding, for gas, the line pressure, and for air, atmospheric pressure, with this added pressure being applied at the *burner*.

CHIMNEY. A primarily vertical structure containing one or more flues, for the purpose of carrying gaseous products of *combustion* and air from an *appliance* to the outside atmosphere.

Factory-built chimney. A *listed* and *labeled* chimney composed of factory-made components, assembled in the field in accordance with manufacturer's instructions and the conditions of the listing.

Masonry chimney. A field-constructed chimney composed of solid masonry units, bricks, stones or concrete.

CLEARANCE. The minimum distance through air measured between the heat-producing surface of the mechanical *appliance*, device or *equipment* and the surface of the *combustible material* or *assembly*.

~~**CLOTHES DRYER.** An *appliance* used to dry wet laundry by means of heated air.~~

~~**Type 1.** Factory built package, multiple production. Primarily used in the family living environment. Usually the smallest unit physically and in function output.~~

~~**CODE.** These regulations, subsequent amendments thereto, or any emergency rule or regulation that the administrative authority having jurisdiction has lawfully adopted.~~

~~**CODE OFFICIAL.** The officer or other designated authority charged with the administration and enforcement of this code, or a duly authorized representative.~~

COMBUSTIBLE ASSEMBLY. Wall, floor, ceiling or other assembly constructed of one or more component materials that are not defined as noncombustible.

COMBUSTIBLE MATERIAL. Any material not defined as noncombustible.

COMBUSTION. In the context of this code, refers to the rapid oxidation of fuel accompanied by the production of heat or heat and light.

COMBUSTION AIR. Air necessary for complete combustion of a fuel, including theoretical air and excess air.

COMBUSTION CHAMBER. The portion of an *appliance* within which combustion occurs.

COMBUSTION PRODUCTS. Constituents resulting from the combustion of a fuel with the oxygen of the air, including the inert gases, but excluding excess air.

CONCEALED LOCATION. A location that cannot be accessed without damaging permanent parts of the building structure or finish surface. Spaces above, below or behind readily removable panels or doors shall not be considered as concealed.

CONCEALED PIPING. *Piping* that is located in a *concealed location* (see “*Concealed location*”).

CONDENSATE. The liquid that condenses from a gas (including flue gas) caused by a reduction in temperature or increase in pressure.

CONNECTOR, APPLIANCE (Fuel). Rigid metallic *pipe* and fittings, semirigid metallic *tubing* and fittings or a *listed* and *labeled* device that connects an *appliance* to the *gas piping system*.

CONNECTOR, CHIMNEY OR VENT. The *pipe* that connects an *appliance* to a chimney or vent.

CONTROL. A manual or automatic device designed to regulate the gas, air, water or electrical supply to, or operation of, a mechanical system.

CONVERSION BURNER. A unit consisting of a *burner* and its *controls* for installation in an *appliance* originally utilizing another fuel.

COPPER ALLOY. A homogeneous mixture of not less than two metals where not less than 50 percent of the finished metal is copper.

CUBIC FOOT. The amount of gas that occupies 1 cubic foot (0.02832 m³) when at a temperature of 60°F (16°C), saturated with water vapor and under a pressure equivalent to that of 30 inches of mercury (101 kPa).

DAMPER. A manually or automatically controlled device to regulate *draft* or the rate of flow of air or combustion gases.

DECORATIVE APPLIANCE, VENTED. A *vented appliance* wherein the primary function lies in the aesthetic effect of the flames.

DECORATIVE APPLIANCES FOR INSTALLATION IN VENTED FIREPLACES. A *vented appliance* designed for installation within the fire chamber of a *vented fireplace*, wherein the primary function lies in the aesthetic effect of the flames.

DEMAND. The maximum amount of gas input required per unit of time, usually expressed in cubic feet per hour, or *Btu/h* (1 *Btu/h* = 0.2931 W).

DESIGN FLOOD ELEVATION. The elevation of the “design flood,” including wave height, relative to the datum specified on the community’s legally designated flood hazard map [as established by the flood plain administrator](#). ~~In areas designated as Zone AO, the design flood elevation shall be the elevation of the highest existing grade of the building’s perimeter plus the depth number (in feet) specified on the flood hazard map. In areas designated as Zone AO where a depth number is not specified on the map, the depth number shall be taken as being equal to 2 feet (610 mm).~~

DILUTION AIR. Air that is introduced into a *draft hood* and is mixed with the *flue gases*.

DIRECT-VENT APPLIANCES. *Appliances* that are constructed and installed so that all air for combustion is derived directly from the outside atmosphere and all *flue gases* are discharged directly to the outside atmosphere.

DRAFT. The pressure difference existing between the *appliance* or any component part and the atmosphere, that causes a continuous flow of air and products of combustion through the gas passages of the *appliance* to the atmosphere.

Mechanical or induced draft. The pressure difference created by the action of a fan, blower or ejector that is located between the *appliance* and the chimney or vent termination.

Natural draft. The pressure difference created by a vent or chimney because of its height, and the temperature difference between the *flue gases* and the atmosphere.

DRAFT HOOD. A nonadjustable device built into an *appliance*, or made as part of the *vent connector* from an *appliance*, that is designed to: provide for ready escape of the *flue gases* from the *appliance* in the event of no *draft*, backdraft, or stoppage beyond the *draft hood*; prevent a backdraft from entering the *appliance*; and neutralize the effect of stack action of the chimney or gas vent upon operation of the *appliance*.

DRAFT REGULATOR. A device that functions to maintain a desired *draft* in the *appliance* by automatically reducing the *draft* to the desired value.

DRIP. The container placed at a low point in a system of *pipng* to collect *condensate* and from which the *condensate* is removable.

DUCT FURNACE. A warm-air *furnace* normally installed in an air-distribution duct to supply warm air for heating. This definition shall apply only to a warm-air heating *appliance* that depends for air circulation on a blower not furnished as part of the *furnace*.

~~**DWELLING UNIT.** A single unit providing complete, independent living facilities for one or more persons, including permanent provisions for living, sleeping, eating, cooking and sanitation.~~

EQUIPMENT. Apparatus and devices other than *appliances*.

EXCESS FLOW VALVE (EFV). A valve designed to activate when the fuel gas passing through it exceeds a prescribed flow rate.

EXTERIOR MASONRY CHIMNEYS. Masonry chimneys exposed to the outdoors on one or more sides below the roof line.

~~**FIREPLACE.** A fire chamber and hearth constructed of noncombustible material for use with solid fuels and provided with a chimney.~~

~~**Factory-built fireplace.** A fireplace composed of listed factory built components assembled in accordance with the terms of listing to form the completed fireplace.~~

~~**Masonry fireplace.** A hearth and fire chamber of solid masonry units such as bricks, stones, listed masonry units or reinforced concrete, provided with a suitable chimney.~~

FLAME SAFEGUARD. A device that will automatically shut off the fuel supply to a *main burner* or group of *burners* when the means of ignition of such *burners* becomes inoperative, and when flame failure occurs on the *burner* or group of *burners*.

FLASHBACK ARRESTOR CHECK VALVE. A device that will prevent the backflow of one gas into the supply system of another gas and prevent the passage of flame into the gas supply system.

~~**FLOOD HAZARD AREA.** The greater of the following two areas:~~

- ~~1. The area within a floodplain subject to a 1 percent or greater chance of flooding in any given year.~~
- ~~2. This area designated as a flood hazard area on a community's flood hazard map, or otherwise legally designated.~~

FLOOR FURNACE. A completely self-contained *furnace* suspended from the floor of the space being heated, taking air for combustion from outside such space and with means for observing flames and lighting the *appliance* from such space.

FLUE, APPLIANCE. The passage(s) within an *appliance* through which *combustion products* pass from the *combustion chamber* of the *appliance* to the *draft hood* inlet opening on an *appliance* equipped with a *draft hood* or to the outlet of the *appliance* on an *appliance* not equipped with a *draft hood*.

~~**FLUE COLLAR.** That portion of an *appliance* designed for the attachment of a *draft hood*, *vent connector* or *venting system*.~~

~~**FLUE GASES.** Products of combustion plus excess air in *appliance flues* or heat exchangers.~~

FLUE LINER (LINING). A system or material used to form the inside surface of a flue in a *chimney* or vent, for the purpose of protecting the surrounding structure from the effects of *combustion products* and for conveying *combustion products* without leakage to the atmosphere.

FUEL GAS. A natural gas, manufactured gas, *liquefied petroleum gas* or mixtures of these gases.

FURNACE. A completely self-contained heating unit that is designed to supply heated air to spaces remote from or adjacent to the *appliance* location.

FURNACE, CENTRAL. A self-contained *appliance* for heating air by transfer of heat of *combustion* through metal to the air, and designed to supply heated air through ducts to spaces remote from or adjacent to the *appliance* location.

FURNACE PLENUM. An air compartment or chamber to which one or more ducts are connected and that forms part of an air distribution system.

GAS CONVENIENCE OUTLET. A permanently mounted, manually operated device that provides the means for connecting an *appliance* to, and disconnecting an *appliance* from, the supply *pipng*. The device includes an integral, manually operated valve with a nondisplaceable valve member and is designed so that disconnection of an *appliance* only occurs when the manually operated valve is in the closed position.

GAS PIPING. An installation of pipe, valves or fittings installed on a premises or in a building and utilized to convey fuel gas.

HAZARDOUS LOCATION. Any location considered to be a fire hazard for flammable vapors, dust, combustible fibers or other highly combustible substances. The location is not necessarily categorized in the ~~International Building Code~~ as a high-hazard use group classification.

HOUSE PIPING. See “*Piping system.*”

IGNITION PILOT. A *pilot* that operates during the lighting cycle and discontinues during *main burner* operation.

IGNITION SOURCE. A flame spark or hot surface capable of igniting flammable vapors or fumes. Such sources include *appliance burners*, *burner ignitors* and electrical switching devices.

INFRARED RADIANT HEATER. A heater that directs a substantial amount of its energy output in the form of infrared radiant energy into the area to be heated. Such heaters are of either the vented or unvented type.

JOINT, FLARED. A metal-to-metal compression joint in which a conical spread is made on the end of a tube that is compressed by a flare nut against a mating flare.

JOINT, MECHANICAL. A general form of gastight joints obtained by the joining of metal parts through a positive-holding mechanical construction, such as a press-connect joint, flanged joint, threaded joint, flared joint or compression joint.

JOINT, PLASTIC ADHESIVE. A joint made in thermoset plastic *piping* by the use of an adhesive substance that forms a continuous bond between the mating surfaces without dissolving either one of them.

LABELED. Equipment, materials or products to which have been affixed a label, seal, symbol or other identifying mark of a nationally recognized testing laboratory, inspection agency or other organization concerned with product evaluation that maintains periodic inspection of the production of the above *labeled* items and whose labeling indicates either that the *equipment*, material or product meets identified standards or has been tested and found suitable for a specified purpose.

LEAK CHECK. An operation performed on a gas *piping system* to verify that the system does not leak.

LIQUEFIED PETROLEUM GAS or LPG (LP-GAS). *Liquefied petroleum gas* composed predominately of propane, propylene, butanes or butylenes, or mixtures thereof that is gaseous under normal atmospheric conditions, but is capable of being liquefied under moderate pressure at normal temperatures.

LISTED. Equipment, materials, products or services included in a list published by an organization acceptable to the ~~building official code official~~ and concerned with evaluation of products or services that maintains periodic inspection of production of *listed equipment* or materials or periodic evaluation of services and whose listing states either that the *equipment*, material, product or service meets identified standards or has been tested and found suitable for a specified purpose.

~~**LIVING SPACE.** Space within a dwelling unit utilized for living, sleeping, eating, cooking, bathing, washing and sanitation purposes.~~

LOG LIGHTER. A manually operated solid-fuel ignition *appliance* for installation in a vented solid-fuel-burning *fireplace*.

MAIN BURNER. A device or group of devices essentially forming an integral unit for the final conveyance of gas or a mixture of gas and air to the combustion zone, and on which combustion takes place to accomplish the function for which the *appliance* is designed.

METER. The instrument installed to measure the volume of gas delivered through it.

MODULATING. Modulating or throttling is the action of a *control* from its maximum to minimum position in either predetermined steps or increments of movement as caused by its actuating medium.

NONCOMBUSTIBLE MATERIALS. Materials that, where tested in accordance with ASTM E136, have not fewer than three of four specimens tested meeting all of the following criteria:

1. The recorded temperature of the surface and interior thermocouples shall not at any time during the test rise more than 54°F (30°C) above the furnace temperature at the beginning of the test.
2. There shall not be flaming from the specimen after the first 30 seconds.
3. If the weight loss of the specimen during testing exceeds 50 percent, the recorded temperature of the surface and interior thermocouples shall not at any time during the test rise above the furnace air temperature at the beginning of the test, and there shall not be flaming of the specimen.

OFFSET (VENT). A combination of *approved* bends that make two changes in direction bringing one section of the vent out of line, but into a line parallel with the other section.

OUTLET. The point at which a gas-fired *appliance* connects to the gas *piping system*.

OXYGEN DEPLETION SAFETY SHUTOFF SYSTEM (ODS). A system designed to act to shut off the gas supply to the main and *pilot burners* if the oxygen in the surrounding atmosphere is reduced below a predetermined level.

PILOT. A small flame that is utilized to ignite the gas at the *main burner* or *burners*.

PIPING. Where used in this code, “*piping*” refers to either *pipe* or *tubing*, or both.

Pipe. A rigid conduit of iron, steel, copper, copper-alloy or plastic.

Tubing. Semirigid conduit of copper, copper-alloy, aluminum, plastic or steel.

PIPING SYSTEM. The fuel *piping*, valves and fittings from the outlet of the *point of delivery* to the outlets of the *appliance* shutoff valves.

PLASTIC, THERMOPLASTIC. A plastic that is capable of being repeatedly softened by increase of temperature and hardened by decrease of temperature.

POINT OF DELIVERY. For natural gas systems, the *point of delivery* is the outlet of the service meter assembly or the outlet of the service regulator or service shutoff valve where a meter is not provided. Where a **system shutoff** valve is provided **after** the outlet of the service meter assembly, such valve shall be considered to be downstream of the *point of delivery*. For undiluted liquefied petroleum gas systems, the point of delivery shall be considered to be the outlet of the ~~service-first-stage~~ **pressure regulator, exclusive of line gas regulators, in the system.**

PRESS-CONNECT JOINT. A permanent mechanical joint incorporating an elastomeric seal or an elastomeric seal and corrosion-resistant grip or bite ring. The joint is made with a pressing tool and jaw or ring approved by the fitting manufacturer.

PRESSURE DROP. The loss in pressure due to friction or obstruction in pipes, valves, fittings, *regulators* and *burners*.

PRESSURE TEST. An operation performed to verify the gastight integrity of *gas piping* following its installation or modification.

PURGE. To free a gas conduit of air or gas, or a mixture of gas and air.

READY ACCESS (TO). That which enables a device, *appliance* or *equipment* to be directly reached, without requiring the removal or movement of any panel, door or similar obstruction. (See "Access.")

REGULATOR. A device for controlling and maintaining a uniform gas supply pressure, either pounds-to-inches water column (MP regulator) or inches-to-inches water column (*appliance regulator*).

REGULATOR, GAS APPLIANCE. A *pressure regulator* for controlling pressure to the manifold of the *gas appliance*.

REGULATOR, LINE GAS PRESSURE. A device placed in a gas line between the *service pressure regulator* and the *appliance* for controlling, maintaining or reducing the pressure in that portion of the *piping system* downstream of the device.

REGULATOR, MEDIUM-PRESSURE (MP Regulator). A *line pressure regulator* that reduces gas pressure from the range of greater than 0.5 psig (3.4 kPa) and less than or equal to 5 psig (34.5 kPa) to a lower pressure.

REGULATOR, MONITORING. A **pressure regulator set in series with another pressure regulator for the purpose of preventing an overpressure in the downstream piping system.**

REGULATOR, PRESSURE. A device placed in a gas line for reducing, controlling and maintaining the pressure in that portion of the *piping system* downstream of the device.

REGULATOR, SERVICE PRESSURE. For natural gas systems, a device installed by the serving gas supplier to reduce and limit the service line pressure to delivery pressure. For undiluted liquefied petroleum gas systems, the regulator located upstream from all line gas pressure regulators, where installed, and downstream from any first stage or a high pressure regulator in the system.

RELIEF OPENING. The opening provided in a *draft hood* to permit the ready escape to the atmosphere of the flue products from the *draft hood* in the event of no *draft*, backdraft or stoppage beyond the *draft hood*, and to permit air into the *draft hood* in the event of a strong chimney updraft.

RELIEF VALVE (DEVICE). A safety valve designed to forestall the development of a dangerous condition by relieving either pressure, temperature or vacuum in the hot water supply system.

RELIEF VALVE, PRESSURE. An *automatic valve* that opens and closes a relief vent, depending on whether the pressure is above or below a predetermined value.

RELIEF VALVE, TEMPERATURE.

Manual reset type. A valve that automatically opens a *relief vent* at a predetermined temperature and that must be manually returned to the closed position.

Reseating or self-closing type. An *automatic valve* that opens and closes a relief vent, depending on whether the temperature is above or below a predetermined value.

RELIEF VALVE, VACUUM. A valve that automatically opens and closes a vent for relieving a vacuum within the hot water supply system, depending on whether the vacuum is above or below a predetermined value.

RISER, GAS. A vertical *pipe* supplying fuel gas.

ROOM HEATER, UNVENTED. See "*Unvented room heater.*"

ROOM HEATER, VENTED. A free-standing heating unit used for direct heating of the space in and adjacent to that in which the unit is located. (See "*Vented room heater.*")

SAFETY SHUTOFF DEVICE. See "*Flame safeguard.*"

SERVICE METER ASSEMBLY. The meter, valve, regulator, piping, fittings and equipment installed by the service gas supplier before the *point of delivery*.

SHAFT. An enclosed space extending through one or more stories of a building, connecting vertical openings in successive floors, or floors and the roof.

SPECIFIC GRAVITY. As applied to gas, *specific gravity* is the ratio of the weight of a given volume to that of the same volume of air, both measured under the same condition.

SYSTEM SHUTOFF. A valve installed after the *point of delivery* to shut off the entire piping system.

THERMOSTAT. (See types that follow.)

Electric switch type. A device that senses changes in temperature and controls electrically, by means of separate components, the flow of gas to the *burner(s)* to maintain selected temperatures.

Integral gas valve type. An automatic device, actuated by temperature changes, designed to control the gas supply to the burner(s) in order to maintain temperatures between predetermined limits, and in which the thermal actuating element is an integral part of the device.

1. Graduating thermostat. A thermostat in which the motion of the valve is approximately in direct proportion to the effective motion of the thermal element induced by temperature change.
2. Snap-acting thermostat. A thermostat in which the thermostatic valve travels instantly from the closed to the open position, and vice versa.

~~**THIRD-PARTY CERTIFICATION AGENCY.** An approved agency operating a product or material certification system that incorporates initial product testing, assessment and surveillance of a manufacturer's quality control system.~~

~~**THIRD-PARTY CERTIFIED.** Certification obtained by the manufacturer indicating that the function and performance characteristics of a product or material have been determined by testing and ongoing surveillance by an approved third party certification agency. Assertion of certification is in the form of identification in accordance with the requirements of the third party certification agency.~~

THIRD-PARTY TESTED. Procedure by which an approved testing laboratory provides documentation that a product, material or system conforms to specified requirements.

TOILET, GAS-FIRED. A packaged and completely assembled appliance containing a toilet that incinerates refuse instead of flushing it away with water.

TRANSITION FITTINGS, PLASTIC TO STEEL. An adapter for joining plastic *pipe* to steel *pipe*. The purpose of this fitting is to provide a permanent, pressure-tight connection between two materials that cannot be joined directly one to another.

UNIT HEATER. A self-contained, automatically controlled, vented, fuel-gas-burning, space-heating *appliance*, intended for installation in the space to be heated without the use of ducts, and having integral means for circulation of air.

UNVENTED ROOM HEATER. An unvented heating *appliance* designed for stationary installation and utilized to provide comfort heating. Such *appliances* provide radiant heat or convection heat by gravity or fan circulation directly from the heater and do not utilize ducts.

VALVE. A device used in *piping* to control the gas supply to any section of a system of *piping* or to an *appliance*.

Appliance shutoff. A *valve* located in the *piping system*, used to isolate individual *appliances* for purposes such as service or replacement.

Automatic. An automatic or semiautomatic device consisting essentially of a *valve* and an operator that control the gas supply to the *burner(s)* during operation of an *appliance*. The operator shall be actuated by application of gas pressure on a flexible diaphragm, by electrical means, by mechanical means or by other *approved* means.

Automatic gas shutoff. A *valve* used in conjunction with an automatic gas shutoff device to shut off the gas supply to a water-heating system. It shall be constructed integrally with the gas shutoff device or shall be a separate assembly.

Individual main burner. A *valve* that controls the gas supply to an individual *main burner*.

Main burner control. A *valve* that controls the gas supply to the *main burner* manifold.

Manual main gas-control. A manually operated *valve* in the gas line for the purpose of completely turning on or shutting off the gas supply to the *appliance*, except to *pilot* or *pilots* that are provided with independent shutoff.

Manual reset. An automatic shutoff valve installed in the gas supply *piping* and set to shut off when unsafe conditions occur. The device remains closed until manually reopened.

Service shutoff. A valve, installed by the serving gas supplier between the source of supply and the *point of delivery*, to shut off the entire *piping system*.

VENT. A *pipe* or other conduit composed of factory-made components, containing a passageway for conveying *combustion products* and air to the atmosphere, *listed* and *labeled* for use with a specific type or class of *appliance*.

Special gas vent. A vent *listed* and *labeled* for use with *listed* Category II, III and IV gas *appliances*.

Type B vent. A vent *listed* and *labeled* for use with *appliances* with *draft hoods* and other Category I *appliances* that are *listed* for use with Type B vents.

Type BW vent. A vent *listed* and *labeled* for use with wall *furnaces*.

Type L vent. A vent *listed* and *labeled* for use with *appliances* that are *listed* for use with Type L or Type B vents.

VENT CONNECTOR. See “*Connector, Chimney or Vent.*”

VENT PIPING.

Breather. *Piping* run from a pressure-regulating device to the outdoors, designed to provide a reference to *atmospheric pressure*. If the device incorporates an integral pressure *relief* mechanism, a breather vent can also serve as a *relief* vent.

Relief. *Piping* run from a pressure-regulating or pressure-limiting device to the outdoors, designed to provide for the safe venting of gas in the event of excessive pressure in the *gas piping system*.

VENTED APPLIANCE CATEGORIES. *Appliances* that are categorized for the purpose of vent selection are classified into the following four categories:

Category I. An *appliance* that operates with a nonpositive vent static pressure and with a vent gas temperature that avoids excessive *condensate* production in the vent.

Category II. An *appliance* that operates with a nonpositive vent static pressure and with a vent gas temperature that is capable of causing excessive *condensate* production in the vent.

Category III. An *appliance* that operates with a positive vent static pressure and with a vent gas temperature that avoids excessive *condensate* production in the vent.

Category IV. An *appliance* that operates with a positive vent static pressure and with a vent gas temperature that is capable of causing excessive *condensate* production in the vent.

VENTED ROOM HEATER. A vented self-contained, freestanding, nonrecessed *appliance* for furnishing warm air to the space in which it is installed, directly from the heater without duct connections.

VENTED WALL FURNACE. A self-contained vented *appliance* complete with grilles or equivalent, designed for incorporation in or permanent attachment to the structure of a building, mobile home or travel trailer, and furnishing heated air circulated by gravity or by a fan directly into the space to be heated through openings in the casing. This definition shall exclude *floor furnaces, unit heaters and central furnaces* as herein defined.

VENTING SYSTEM. A continuous open passageway from the *flue collar* or *draft hood* of an *appliance* to the outdoor atmosphere for the purpose of removing flue or vent gases. A venting system is usually composed of a vent or a chimney and *vent connector*, if used, assembled to form the open passageway.

WALL HEATER, UNVENTED TYPE. A room heater of the type designed for insertion in or attachment to a wall or partition. Such heater does not incorporate concealed venting arrangements in its construction and discharges all products of *combustion* through the front into the room being heated.

WATER HEATER. Any heating *appliance* or *equipment* that heats potable water and supplies such water to the potable hot water distribution system.

SECTION G2404 ~~(301)~~ GENERAL

G2404.1 ~~(301.1)~~ Scope. This section shall govern the approval and installation of all *equipment* and *appliances* that comprise parts of the installations regulated by this *code* in accordance with Section G2401.

G2404.2 ~~(301.1.1)~~ Other fuels. The requirements for *combustion* and *dilution air* for gas-fired *appliances* shall be governed by Section G2407. The requirements for *combustion* and *dilution air* for *appliances* operating with fuels other than fuel gas shall be regulated by Chapter 17.

G2404.3 ~~(301.3)~~ Listed and labeled. *Appliances* regulated by this *code* shall be *listed* and *labeled* for the application in which they are used unless otherwise *approved* in accordance with Section R104.11. The approval of unlisted *appliances* in accordance with Section R104.11 shall be based on *approved engineering* evaluation.

G2404.4 ~~(301.8)~~ Vibration isolation. Where means for isolation of vibration of an *appliance* is installed, an *approved* means for support and restraint of that *appliance* shall be provided.

G2404.5 ~~(301.9)~~ Repair. Defective material or parts shall be replaced or repaired in such a manner so as to preserve the original approval or listing.

G2404.6 ~~(301.10)~~ Reserved. Wind resistance. ~~*Appliances and supports that are exposed to wind shall be designed and installed to resist the wind pressures determined in accordance with this code.*~~

G2404.7 ~~(301.11)~~ Flood hazard. For structures located in flood hazard areas, as established by the *flood plain administrator*, the appliance, equipment and system installations regulated by this code shall be located at or above the elevation required by Section R322 for utilities and attendant equipment.

Exception: The appliance, equipment and system installations regulated by this code are permitted to be located below the elevation required by Section R322 for utilities and attendant equipment provided that they are designed and installed to prevent water from entering or accumulating within the components and to resist hydrostatic and hydrodynamic loads and stresses, including the effects of buoyancy, during the occurrence of flooding to such elevation.

G2404.8 ~~(301.12)~~ Reserved. Seismic resistance. ~~*Where earthquake loads are applicable in accordance with this code, the supports shall be designed and installed for the seismic forces in accordance with this code.*~~

G2404.9 ~~(301.14)~~ Rodentproofing. Buildings or structures and the walls enclosing habitable or occupiable rooms and spaces in which persons live, sleep or work, or in which feed, food or foodstuffs are stored, prepared, processed, served or sold, shall be constructed to protect against the entry of rodents.

G2404.10—(307.5) Auxiliary drain pan. Category IV condensing *appliances* shall be provided with an auxiliary drain pan where damage to any building component will occur as a result of stoppage in the *condensate* drainage system. Such pan shall be installed in accordance with the applicable provisions of Section M1411.

Exception: An auxiliary drain pan shall not be required for *appliances* that automatically shut down operation in the event of a stoppage in the *condensate* drainage system.

G2404.11—(307.6) Condensate pumps. Condensate pumps located in uninhabitable spaces, such as attics and crawl spaces, shall be connected to the *appliance* or *equipment* served such that when the pump fails, the *appliance* or *equipment* will be prevented from operating. Pumps shall be installed in accordance with the manufacturer's instructions.

SECTION G2405—(302) STRUCTURAL SAFETY

G2405.1 (302.1) Structural safety. The building shall not be weakened by the installation of any gas *pipng*. In the process of installing or repairing any gas *pipng*, the finished floors, walls, ceilings, tile work or any other part of the building or premises that is required to be changed or replaced shall be left in a safe structural condition in accordance with the requirements of this code.

G2405.2—(302.4) Alterations to trusses. Truss members and components shall not be cut, drilled, notched, spliced or otherwise altered in any way without the ~~written concurrence and approval of a *nonprescriptive design*—*registered design professional*.~~ *Alterations* resulting in the addition of loads to any member, such as HVAC equipment and water heaters, shall not be permitted without verification that the truss is capable of supporting such additional loading.

G2405.3 (302.3.1) Engineered wood products. Cuts, notches and holes bored in trusses, structural composite lumber, structural glued-laminated members and I-joists are prohibited except where permitted by the manufacturer's recommendations or where the effects of such *alterations* are specifically considered in the ~~*nonprescriptive design*—*of the member by a registered design professional*.~~

SECTION G2406—(303) APPLIANCE LOCATION

G2406.1 (303.1)—General. *Appliances* shall be located as required by this section, specific requirements elsewhere in this code and the conditions of the *equipment* and *appliance* listing.

G2406.2 (303.3)—Prohibited locations. *Appliances* shall not be located in sleeping rooms, bathrooms, toilet rooms, storage closets or surgical rooms, or in a space that opens only into such rooms or spaces, except where the installation complies with one of the following:

1. The *appliance* is a direct-vent *appliance* installed in accordance with the conditions of the listing and the manufacturer's instructions.
2. *Vented room heaters*, wall *furnaces*, vented decorative *appliances*, vented gas *fireplaces*, vented gas *fireplace heaters* and decorative *appliances* for installation in vented solid fuel-burning *fireplaces* are installed in rooms that meet the required volume criteria of Section G2407.5.
3. A single wall-mounted *unvented room heater* is installed in a bathroom and such *unvented room heater* is equipped as specified in Section G2445.6 and has an input rating not greater than 6,000 *Btu/h* (1.76 kW). The bathroom shall meet the required volume criteria of Section G2407.5.
4. A single wall-mounted *unvented room heater* is installed in a bedroom and such *unvented room heater* is equipped as specified in Section G2445.6 and has an input rating not greater than 10,000 *Btu/h* (2.93 kW). The bedroom shall meet the required volume criteria of Section G2407.5.
5. The *appliance* is installed in a room or space that opens only into a bedroom or bathroom, and such room or space is used for no other purpose and is provided with a solid weather-stripped door equipped with an *approved* self-closing device. *Combustion air* shall be taken directly from the outdoors in accordance with Section G2407.6.
6. A clothes dryer is installed in a residential bathroom or toilet room having a permanent opening with an area of not less than 100 square inches (0.06 m²) that communicates with a space outside of a sleeping room, bathroom, toilet room or storage closet.

G2406.3—(303.6) Outdoor locations. *Appliances* installed in outdoor locations shall be either listed for outdoor installation or provided with protection from outdoor environmental factors that influence the operability, durability and safety of the *appliance*.

SECTION G2407—(304) COMBUSTION, VENTILATION AND DILUTION AIR

G2407.1—(304.1) General. Air for *combustion*, ventilation and dilution of *flue gases* for *appliances* installed in buildings shall be provided by application of one of the methods prescribed in Sections G2407.5 through G2407.9. Where the requirements of Section G2407.5 are not met, outdoor air shall be introduced in accordance with one of the methods prescribed in Sections G2407.6 through G2407.9. *Direct vent appliances*, gas *appliances* of other than *natural draft* design, vented gas *appliances* not designated as Category I and *appliances* equipped with power burners, shall be provided with *combustion*, ventilation and *dilution air* in accordance with the *appliance* manufacturer's instructions.

Exception: *Type 1 clothes dryers* that are provided with *makeup air* in accordance with Section ~~G2439.5~~ 1502.7.

G2407.2 ~~(304.2)~~ **Appliance location.** *Appliances* shall be located so as not to interfere with proper circulation of *combustion*, ventilation and *dilution air*.

G2407.3 ~~(304.3)~~ **Draft hood/regulator location.** Where used, a *draft hood* or a *barometric draft regulator* shall be installed in the same room or enclosure as the *appliance* served to prevent any difference in pressure between the hood or regulator and the *combustion air* supply.

G2407.4 ~~(304.4)~~ **Makeup air provisions.** Where exhaust fans, *clothes dryers* and kitchen ventilation systems interfere with the operation of *appliances*, *makeup air* shall be provided.

G2407.4.1 Special conditions. In buildings containing combustion appliances, equipment or fireplaces not equipped with forced or induced draft or separated from the habitable area, where an individual exhaust appliance exceeds 350 cfm (165.2 L/s), make-up air of sufficient quantity to equal that being exhausted shall be supplied to the area being ventilated. In such cases, the minimum size make-up air duct shall be 6 inches (152 mm) in diameter or equivalent area.

G2407.5 ~~(304.5)~~ **Indoor combustion air.** The required volume of indoor air shall be determined in accordance with Section G2407.5.1 or G2407.5.2, except that where the air infiltration rate is known to be less than 0.40 air changes per hour (ACH), Section G2407.5.2 shall be used. The total required volume shall be the sum of the required volume calculated for all *appliances* located within the space. Rooms communicating directly with the space in which the *appliances* are installed through openings not furnished with doors, and through *combustion air* openings sized and located in accordance with Section G2407.5.3, are considered to be part of the required volume.

G2407.5.1 ~~(304.5.1)~~ **Standard method.** The minimum required volume shall be 50 cubic feet per 1,000 *Btu/h* (4.8 m³/kW) of the appliance input rating.

G2407.5.2 ~~(304.5.2)~~ **Known air-infiltration-rate method.** Where the air infiltration rate of a structure is known, the minimum required volume shall be determined as follows:

For *appliances* other than fan-assisted, calculate volume using Equation 24-1.

$$Required\ Volume_{other} \geq 21\ ft^3/ACH\ (I_{other}/1,000\ Btu/h)$$

(Equation 24-1)

For fan-assisted *appliances*, calculate volume using Equation 24-2.

$$Required\ Volume_{fan} \geq 15\ ft^3/ACH\ (I_{fan}/1,000\ Btu/h)$$

(Equation 24-2)

Where:

I_{other} = All *appliances* other than fan assisted (input in *Btu/h*).

I_{fan} = Fan-assisted *appliance* (input in *Btu/h*).

ACH = Air change per hour (percent of volume of space exchanged per hour, expressed as a decimal).

For purposes of this calculation, an infiltration rate greater than 0.60 ACH shall not be used in Equations 24-1 and 24-2.

G2407.5.3 ~~(304.5.3)~~ **Indoor opening size and location.** Openings used to connect indoor spaces shall be sized and located in accordance with Sections G2407.5.3.1 and G2407.5.3.2 (see Figure G2407.5.3).

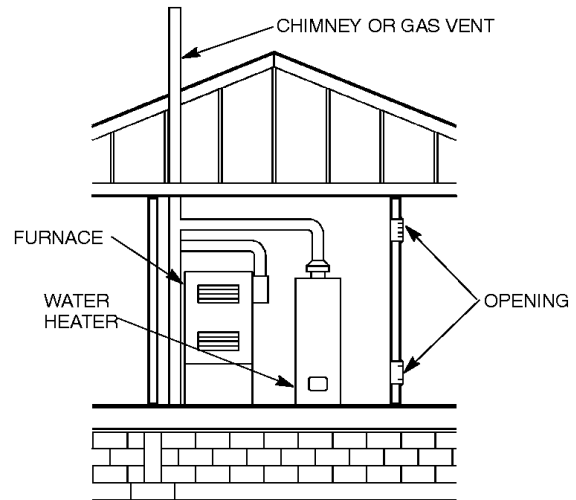

FIGURE G2407.5.3 ~~(304.5.3)~~
ALL AIR FROM INSIDE THE BUILDING
 (see Section G2407.5.3)

G2407.5.3.1 ~~(304.5.3.1)~~ **Combining spaces on the same story.** Where combining spaces on the same story, each opening shall have a minimum free area of 1 square inch per 1,000 *Btu/h* (2,200 mm²/kW) of the total input rating of all *appliances* in the space, but not less than 100 square inches (0.06 m²). One permanent opening shall commence within 12 inches (305 mm) of the top and one permanent opening shall commence within 12 inches (305 mm) of the bottom of the enclosure. The minimum dimension of air openings shall be not less than 3 inches (76 mm).

G2407.5.3.2 ~~(304.5.3.2)~~ **Combining spaces in different stories.** The volumes of spaces in different stories shall be considered to be communicating spaces where such spaces are connected by one or more permanent openings in doors or floors having a total minimum free area of 2 square inches per 1,000 *Btu/h* (4402 mm²/kW) of total input rating of all *appliances*.

G2407.6 ~~(304.6)~~ **Outdoor combustion air.** Outdoor *combustion air* shall be provided through opening(s) to the outdoors in accordance with Section G2407.6.1 or G2407.6.2. The minimum dimension of air openings shall be not less than 3 inches (76 mm).

G2407.6.1—(304.6.1) Two-permanent-openings method.

Two permanent openings, one commencing within 12 inches (305 mm) of the top and one commencing within 12 inches (305 mm) of the bottom of the enclosure, shall be provided. The openings shall communicate directly or by ducts with the outdoors or spaces that freely communicate with the outdoors.

Where directly communicating with the outdoors, or where communicating with the outdoors through vertical ducts, each opening shall have a minimum free area of 1 square inch per 4,000 Btu/h (550 mm²/kW) of total input rating of all appliances in the enclosure [see Figures G2407.6.1(1) and G2407.6.1(2)].

Where communicating with the outdoors through horizontal ducts, each opening shall have a minimum free area of not less than 1 square inch per 2,000 Btu/h (1100 mm²/kW) of total input rating of all appliances in the enclosure [see Figure G2407.6.1(3)].

G2407.6.2—(304.6.2) One-permanent-opening method. One permanent opening, commencing within 12 inches (305 mm) of the top of the enclosure, shall be provided. The appliance shall have clearances of not less than 1 inch (25 mm) from the sides and back and 6 inches (152 mm) from the front of the appliance. The opening shall directly communicate with the outdoors or through a vertical or horizontal duct to the outdoors, or spaces that freely communicate with the outdoors (see Figure G2407.6.2) and shall have a minimum free area of 1 square inch per 3,000 Btu/h (734 mm²/kW) of the total input rating of all appliances located in the enclosure and not less than the sum of the areas of all vent connectors in the space.

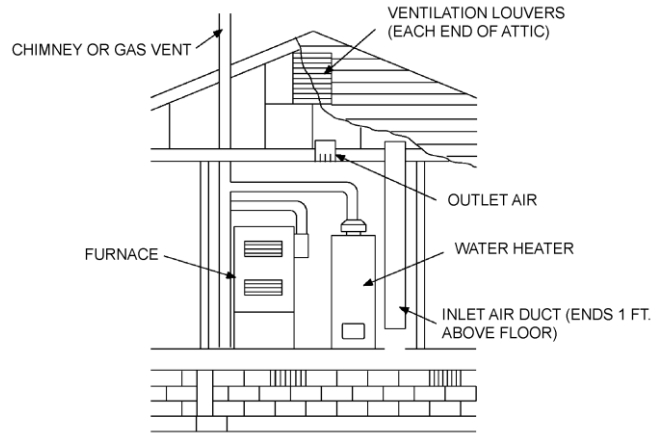

**FIGURE G2407.6.1(2) [304.6.1(2)]
ALL AIR FROM OUTDOORS THROUGH VENTILATED ATTIC
(see Section G2407.6.1)**

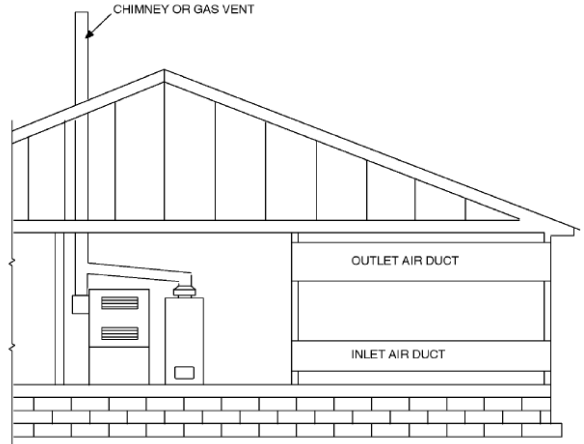

**FIGURE G2407.6.1(3) [304.6.1(3)]
ALL AIR FROM OUTDOORS
(see Section G2407.6.1)**

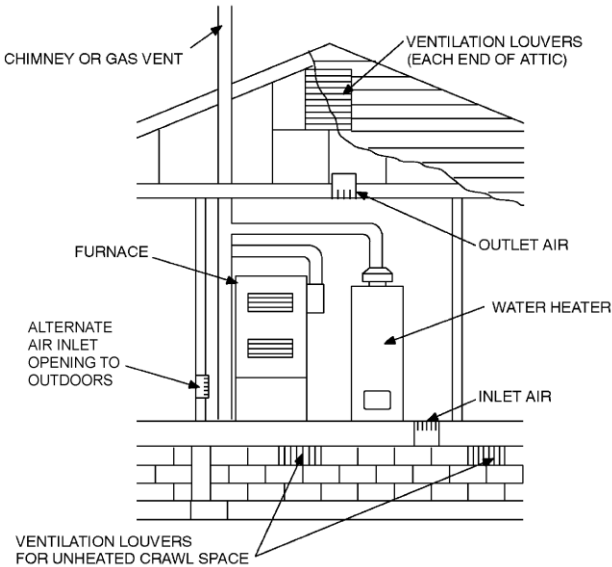

**FIGURE G2407.6.1(1) [304.6.1(1)]
ALL AIR FROM OUTDOORS—INLET AIR FROM VENTILATED
CRAWL SPACE AND OUTLET AIR TO VENTILATED ATTIC
(see Section G2407.6.1)**

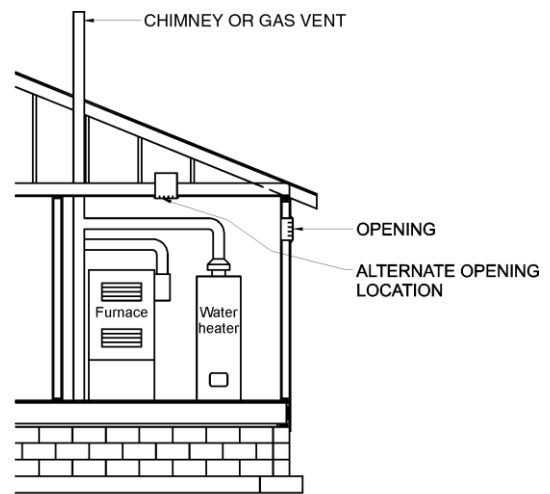

**FIGURE G2407.6.2—(304.6.2)
SINGLE COMBUSTION AIR OPENING, ALL AIR FROM OUTDOORS
(see Section G2407.6.2)**

G2407.7—(304.7) Combination indoor and outdoor combustion air. The use of a combination of indoor and outdoor *combustion air* shall be in accordance with Sections G2407.7.1 through G2407.7.3.

G2407.7.1—(304.7.1) Indoor openings. Where used, openings connecting the interior spaces shall comply with Section G2407.5.3.

G2407.7.2—(304.7.2) Outdoor opening location. Outdoor opening(s) shall be located in accordance with Section G2407.6.

G2407.7.3—(304.7.3) Outdoor opening(s) size. The outdoor opening(s) size shall be calculated in accordance with the following:

1. The ratio of interior spaces shall be the available volume of all communicating spaces divided by the required volume.
2. The outdoor size reduction factor shall be one minus the ratio of interior spaces.
3. The minimum size of outdoor opening(s) shall be the full size of outdoor opening(s) calculated in accordance with Section G2407.6, multiplied by the reduction factor. The minimum dimension of air openings shall be not less than 3 inches (76 mm).

G2407.8—(304.8) Designed ~~Engineered~~ installations. ~~Designed Engineered~~ *combustion air* installations shall provide an adequate supply of *combustion*, ventilation and *dilution air* determined using approved ~~engineering methods~~.

G2407.9—(304.9) Mechanical combustion air supply. Where all *combustion air* is provided by a mechanical air supply system, the *combustion air* shall be supplied from the outdoors at a rate not less than 0.35 cubic feet per minute per 1,000 Btu/h (0.034 m³/min per kW) of total input rating of all *appliances* located within the space.

G2407.9.1—(304.9.1) Makeup air. Where exhaust fans are installed, *makeup air* shall be provided to replace the exhausted air.

G2407.9.2—(304.9.2) Appliance interlock. Each of the *appliances* served shall be interlocked with the mechanical air supply system to prevent *main burner* operation when the mechanical air supply system is not in operation.

G2407.9.3—(304.9.3) Combined combustion air and ventilation air system. Where *combustion air* is provided by the building's mechanical ventilation system, the system shall provide the specified *combustion air* rate in addition to the required ventilation air.

G2407.10—(304.10) Louvers and grilles. The required size of openings for *combustion*, ventilation and *dilution air* shall be based on the net free area of each opening. Where the free area through a design of louver, grille or screen is known, it shall be used in calculating the size opening required to provide the free area specified. Where the design and free area of louvers and grilles are

not known, it shall be assumed that wood louvers will have 25-percent free area and metal louvers and grilles will have 75-percent free area. Screens shall have a mesh size not smaller than 1/4 inch (6.4 mm). Nonmotorized louvers and grilles shall be fixed in the open position. Motorized louvers shall be interlocked with the *appliance* so that they are proven to be in the full open position prior to *main burner* ignition and during *main burner* operation. Means shall be provided to prevent the *main burner* from igniting if the louvers fail to open during *burner* start-up and to shut down the *main burner* if the louvers close during operation.

G2407.11—(304.11) Combustion air ducts. *Combustion air* ducts shall comply with all of the following:

1. Ducts shall be constructed of galvanized steel complying with Chapter 16 or of a material having equivalent corrosion resistance, strength and rigidity.

Exception: Within dwellings units, unobstructed stud and joist spaces shall not be prohibited from conveying *combustion air*, provided that not more than one required fireblock is removed.

2. Ducts shall terminate in an unobstructed space allowing free movement of *combustion air* to the *appliances*.
3. Ducts shall serve a single enclosure.
4. Ducts shall not serve both upper and lower *combustion air* openings where both such openings are used. The separation between ducts serving upper and lower *combustion air* openings shall be maintained to the source of *combustion air*.
5. Ducts shall not be screened where terminating in an attic space.
6. Horizontal upper *combustion air* ducts shall not slope downward toward the source of *combustion air*.
7. The remaining space surrounding a *chimney* liner, gas vent, special gas vent or plastic *piping* installed within a masonry, metal or factory-built *chimney* shall not be used to supply *combustion air*.

Exception: Direct-vent gas-fired *appliances* designed for installation in a solid fuel-burning *fireplace* where installed in accordance with the manufacturer's instructions.
8. *Combustion air* intake openings located on the exterior of a building shall have the lowest side of such openings located not less than 12 inches (305 mm) vertically from the adjoining finished ground level.

G2407.12—(304.12) Protection from fumes and gases. Where corrosive or flammable process fumes or gases, other than products of *combustion*, are present, means for the disposal of such fumes or gases shall be provided. Such fumes or gases include carbon monoxide, hydrogen sulfide, ammonia, chlorine and halogenated hydrocarbons.

In barbershops, beauty shops and other facilities where chemicals that generate corrosive or flammable products, such as aerosol

sprays, are routinely used, nondirect vent-type *appliances* shall be located in a mechanical room separated or partitioned off from other areas with provisions for *combustion air* and *dilution air* from the outdoors. *Direct-vent appliances* shall be installed in accordance with the *appliance* manufacturer's instructions.

SECTION G2408 ~~(305)~~ INSTALLATION

G2408.1 ~~(305.1)~~ General. *Equipment* and *appliances* shall be installed as required by the terms of their approval, in accordance with the conditions of listing, the manufacturer's instructions and this code. Manufacturer's installation instructions shall be available on the job site at the time of inspection. Where a code provision is less restrictive than the conditions of the listing of the *equipment* or *appliance* or the manufacturer's installation instructions, the conditions of the listing and the manufacturer's installation instructions shall apply.

Unlisted *appliances approved* in accordance with Section G2404.3 shall be limited to uses recommended by the manufacturer and shall be installed in accordance with the manufacturer's instructions, the provisions of this code and the requirements determined by the *building official code official*.

G2408.2 ~~(305.3)~~ Elevation of ignition source. *Equipment Heating* and *cooling* appliances, ~~having an ignition source and water heaters covered by this code, located in a garage and generate a glow, spark or flame capable of igniting flammable vapors~~ shall be ~~elevated such that the source installed with sources~~ of ignition is not less than 18 inches (457 mm) above the floor ~~in hazardous locations and public garages, private garages, repair garages, motor fuel dispensing facilities and parking garages. For the purpose of this section, rooms or spaces that are not part of the living space of a dwelling unit and that communicate directly with a private garage through openings shall be considered to be part of the private garage level.~~

Exception: Elevation of the *ignition source* is not required for *appliances* that are *listed* as flammable-vapor-ignition resistant.

G2408.2.1 ~~(305.3.1)~~ Installation in residential garages. In residential garages where *appliances* are installed in a separate, enclosed space having access only from outside of the garage, such *appliances* shall be permitted to be installed at floor level, provided that the required *combustion air* is taken from the exterior of the garage.

G2408.3 ~~(305.5)~~ Private garages. *Appliances* located in private garages shall be installed with a minimum *clearance* of 6 feet (1829 mm) above the floor.

Exception: The requirements of this section shall not apply where the *appliances* are protected from motor vehicle impact. ~~and installed in accordance with Section G2408.2 Figure M1307.3.1 contains examples of normal vehicle paths and acceptable methods of protection.~~

G2408.4 ~~(305.7)~~ Clearances from grade. *Equipment* and *appliances* installed at grade level shall be supported on a level concrete slab or other *approved* material extending not less than 3 inches (76 mm) above adjoining grade or shall be suspended not less than 6 inches (152 mm) above adjoining grade. Such supports shall be installed in accordance with the manufacturer's instructions.

G2408.5 ~~(305.8)~~ Clearances to combustible construction. Heat-producing *equipment* and *appliances* shall be installed to maintain the required clearances to combustible construction as specified in the listing and manufacturer's instructions. Such *clearances* shall be reduced only in accordance with Section G2409. *Clearances* to combustibles shall include such considerations as door swing, drawer pull, overhead projections or shelving and window swing. Devices, such as door stops or limits and closers, shall not be used to provide the required *clearances*.

G2408.6 ~~(305.12)~~ Avoid strain on gas piping. *Appliances* shall be supported and connected to the *piping* so as not to exert undue strain on the connections.

SECTION G2409 ~~(308)~~ CLEARANCE REDUCTION

G2409.1 ~~(308.1)~~ Scope. This section shall govern the reduction in required clearances to *combustible materials*, including gypsum board, and *combustible assemblies* for chimneys, vents, appliances, devices and equipment. Clearance requirements for air-conditioning equipment and ~~central heating boilers and furnaces~~ shall comply with Sections G2409.3 and G2409.4.

G2409.2 ~~(308.2)~~ Reduction table. The allowable *clearance* reduction shall be based on one of the methods specified in Table G2409.2 or shall utilize a reduced *clearance* protective assembly *listed* and *labeled* in accordance with UL 1618. Where required *clearances* are not listed in Table G2409.2, the reduced clearances shall be determined by linear interpolation between the distances listed in the table. Reduced *clearances* shall not be derived by extrapolation below the range of the table. The reduction of the required *clearances* to combustibles for *listed* and *labeled appliances* and *equipment* shall be in accordance with the requirements of this section, except that such *clearances* shall not be reduced where reduction is specifically prohibited by the terms of the *appliance* or *equipment listing* [see Figures G2409.2(1) through 2409.2(3)].

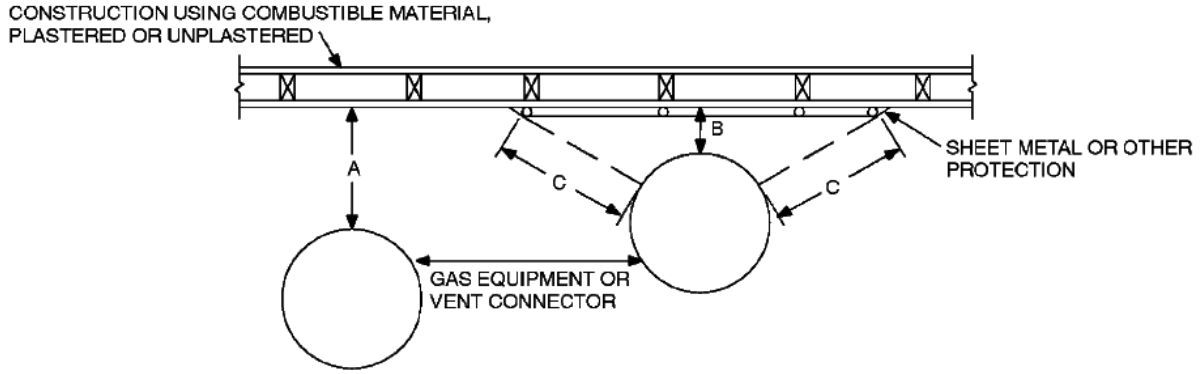

NOTES:

A = the clearance without protection.

B = the reduced clearance permitted in accordance with Table G2409.2. The protection applied to the construction using *combustible material* shall extend far enough in each direction to make "C" equal to "A."

FIGURE G2409.2(1) [308.2(1)]
EXTENT OF PROTECTION NECESSARY TO REDUCE CLEARANCES FROM GAS EQUIPMENT OR VENT CONNECTORS

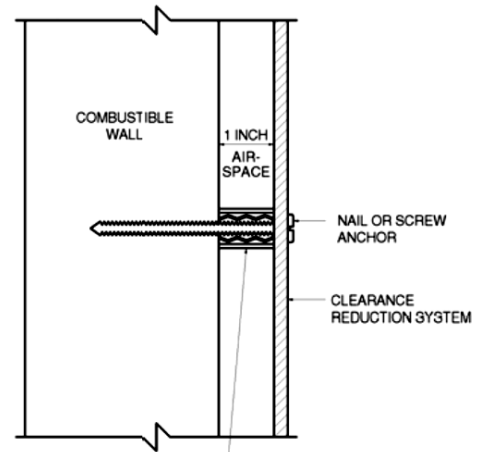
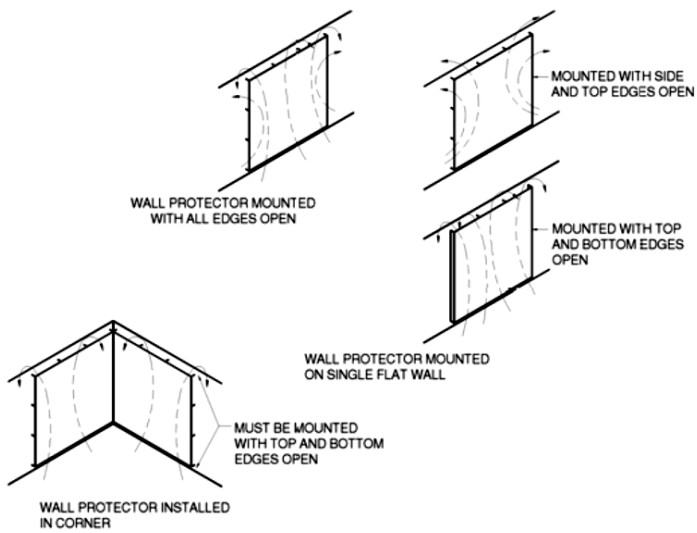

1-INCH NONCOMBUSTIBLE SPACER SUCH AS STACKED WASHERS, SMALL-DIAMETER PIPE, TUBING OR ELECTRICAL CONDUIT.

MASONRY WALLS CAN BE ATTACHED TO COMBUSTIBLE WALLS USING WALL TIES.

DO NOT USE SPACERS DIRECTLY BEHIND APPLIANCE OR CONNECTOR.

For SI: 1 inch = 25.4 mm.

FIGURE G2409.2(2) [308.2(2)]
WALL PROTECTOR CLEARANCE REDUCTION SYSTEM

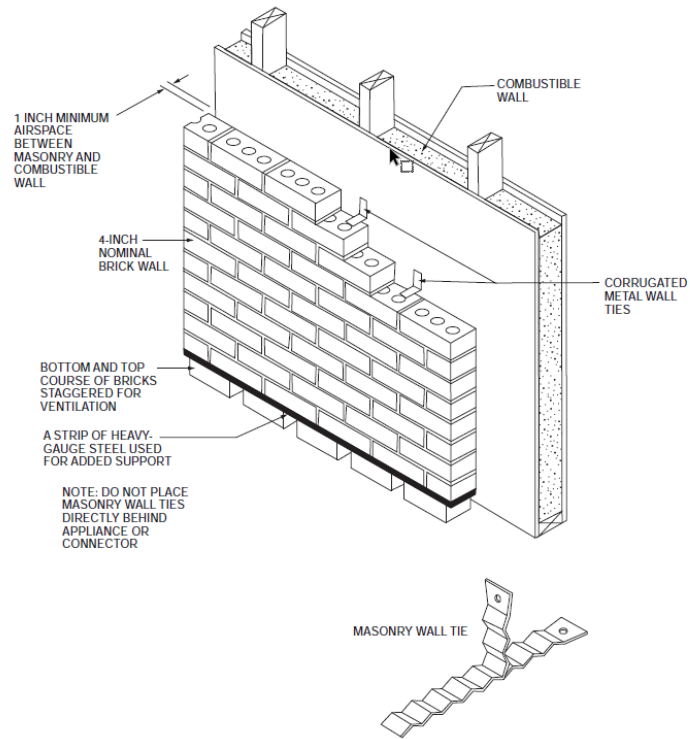

For SI: 1 inch = 25.4 mm.

**FIGURE G2409.2(3) ~~[308.2(3)]~~
MASONRY CLEARANCE REDUCTION SYSTEM**

TABLE G2409.2 ~~(308.2)~~
REDUCTION OF CLEARANCES WITH SPECIFIED FORMS OF PROTECTION ^{a through k}

TYPE OF PROTECTION APPLIED TO AND COVERING ALL SURFACES OF COMBUSTIBLE MATERIAL WITHIN THE DISTANCE SPECIFIED AS THE REQUIRED CLEARANCE WITH NO PROTECTION [see Figures G2409.2(1), G2409.2(2), and G2409.2(3)]	WHERE THE REQUIRED CLEARANCE WITH NO PROTECTION FROM APPLIANCE, VENT CONNECTOR, OR SINGLE-WALL METAL PIPE IS: (inches)									
	36		18		12		9		6	
	Allowable clearances with specified protection (inches)									
	Use Column 1 for clearances above appliance or horizontal connector. Use Column 2 for clearances from appliance, vertical connector and single-wall metal pipe.									
	Above Col. 1	Sides and rear Col. 2	Above Col. 1	Sides and rear Col. 2	Above Col. 1	Sides and rear Col. 2	Above Col. 1	Sides and rear Col. 2	Above Col. 1	Sides and rear Col. 2
1. 3½-inch-thick masonry wall without ventilated airspace	—	24	—	12	—	9	—	6	—	5
2. ½-inch insulation board over 1-inch glass fiber or mineral wool batts	24	18	12	9	9	6	6	5	4	3
3. 0.024-inch (nominal 24 gage) sheet metal over 1-inch glass fiber or mineral wool batts reinforced with wire on rear face with ventilated airspace	18	12	9	6	6	4	5	3	3	3
4. 3½-inch-thick masonry wall with ventilated airspace	—	12	—	6	—	6	—	6	—	6
5. 0.024-inch (nominal 24 gage) sheet metal with ventilated airspace	18	12	9	6	6	4	5	3	3	2
6. ½-inch-thick insulation board with ventilated airspace	18	12	9	6	6	4	5	3	3	3
7. 0.024-inch (nominal 24 gage) sheet metal with ventilated airspace over 0.024-inch (nominal 24 gage) sheet metal with ventilated airspace	18	12	9	6	6	4	5	3	3	3
8. 1-inch glass fiber or mineral wool batts sandwiched between two sheets 0.024-inch (nominal 24 gage) sheet metal with ventilated airspace	18	12	9	6	6	4	5	3	3	3

For SI: 1 inch = 25.4 mm, °C = [(°F – 32)/1.8], 1 pound per cubic foot = 16.02 kg/m³, 1 Btu per inch per square foot per hour per °F = 0.144 W/m² × K.

- a. Reduction of clearances from combustible materials shall not interfere with combustion air, draft hood clearance and relief, and accessibility of servicing.
- b. Clearances shall be measured from the outer surface of the combustible material to the nearest point on the surface of the appliance, disregarding any intervening protection applied to the combustible material.
- c. Spacers and ties shall be of noncombustible material. A spacer or tie shall not be used directly opposite an appliance or connector.
- d. For all clearance reduction systems using a ventilated airspace, adequate provision for air circulation shall be provided as described [see Figures G2409.2(2) and G2409.2(3)].
- e. There shall be not less than 1 inch between clearance reduction systems and combustible walls and ceilings for reduction systems using ventilated airspace.
- f. Where a wall protector is mounted on a single flat wall away from corners, it shall have a minimum 1-inch air gap. To provide air circulation, the bottom and top edges, or only the side and top edges, or all edges shall be left open.
- g. Mineral wool batts (blanket or board) shall have a density of 8 pounds per cubic foot and a minimum melting point of 1500°F.
- h. Insulation material used as part of a clearance reduction system shall have a thermal conductivity of 1.0 Btu per inch per square foot per hour per °F or less.
- i. There shall be not less than 1 inch between the appliance and the protector. In no case shall the clearance between the appliance and the combustible surface be reduced below that allowed in this table.
- j. clearances and thicknesses are minimum; larger clearances and thicknesses are acceptable.
- k. Listed single-wall connectors shall be installed in accordance with the manufacturer’s instructions.

G2409.3 ~~(308.3)~~ Clearances for indoor air-conditioning appliances. Clearance requirements for indoor air-conditioning appliances shall comply with Sections G2409.3.1 through G2409.3.4.

G2409.3.2 ~~(308.3.2)~~ Clearance reduction. Air-conditioning appliances shall be permitted to be installed with reduced clearances to combustible material, provided that the combustible material or appliance is protected as described in Table G2409.2 and such reduction is allowed by the manufacturer’s instructions.

G2409.3.1 ~~(308.3.1)~~ Appliances clearances. Air-conditioning appliances shall be installed with clearances in accordance with the manufacturer’s instructions.

G2409.3.3 ~~(308.3.3)~~ Plenum clearances. Where the furnace plenum is adjacent to plaster on metal lath or noncombustible material attached to combustible material, the clearance shall be measured to the surface of the plaster or other noncombustible finish where the clearance specified is 2 inches (51 mm) or less.

G2409.3.4 (308.3.4) Clearance from supply ducts. Supply air ducts connecting to listed central heating furnaces shall have the same minimum clearance to combustibles as required for the furnace supply plenum for a distance of not less than 3 feet (914 mm) from the supply plenum. Clearance is not required beyond the 3-foot (914 mm) distance.

G2409.4 (308.4) Central-heating boilers and furnaces. Clearance requirements for central-heating boilers and furnaces shall comply with Sections G2409.4.1 through G2409.4.5. The clearance to these appliances shall not interfere with combustion air; draft hood clearance and relief; and accessibility for servicing.

G2409.4.1 (308.4.1) Appliances clearances. Central-heating furnaces and low-pressure boilers shall be installed with clearances in accordance with the manufacturer's instructions.

G2409.4.2 (308.4.2) Clearance reduction. Central-heating furnaces and low-pressure boilers shall be permitted to be installed with reduced clearances to combustible material provided that the combustible material or appliance is protected as described in Table G2409.2 and such reduction is allowed by the manufacturer's instructions.

G2409.4.3 (308.4.4) Plenum clearances. Where the furnace plenum is adjacent to plaster on metal lath or noncombustible material attached to combustible material, the clearance shall be measured to the surface of the plaster or other noncombustible finish where the clearance specified is 2 inches (51 mm) or less.

G2409.4.4 (308.4.5) Clearance from supply ducts. Supply air ducts connecting to listed central heating furnaces shall have the same minimum clearance to combustibles as required for the furnace supply plenum for a distance of not less than 3 feet (914 mm) from the supply plenum. Clearance is not required beyond the 3-foot (914 mm) distance.

G2409.4.5 (308.4.3) Clearance for servicing appliances. Front clearance shall be sufficient for servicing the burner and the furnace or boiler.

SECTION G2410 (309) ELECTRICAL

G2410.1 (309.1) Grounding. Gas piping shall not be used as a grounding electrode.

G2410.2 (309.2) Connections. Electrical connections between appliances and the building wiring, including the grounding of the appliances, shall conform to ~~Chapters 34 through 43~~ [the Electrical Code](#).

SECTION G2411 (310) ELECTRICAL BONDING

~~**G2411.1 (310.1) Pipe and tubing other than CSST.** Each above-ground portion of a gas piping system other than corrugated stainless steel tubing (CSST) that is likely to become energized shall be electrically continuous and bonded to an effective ground-fault current path. Gas piping other than CSST shall be considered to be bonded where it is connected to an appliance that is connected to the equipment grounding conductor of the circuit that supplies that appliance.~~

~~**G2411.2 (310.2) CSST.** This section applies to corrugated stainless steel tubing (CSST) that is not listed with an arc-resistant jacket or coating system in accordance with ANSI LCI/CSA 6.26. CSST gas piping systems and piping systems containing one or more segments of CSST shall be electrically continuous and bonded to the electrical service grounding electrode system or, where provided, the lightning protection grounding electrode system.~~

~~**G2411.2.1 (310.2.1) Point of connection.** The bonding jumper shall connect to a metallic pipe, pipe fitting or CSST fitting.~~

~~**G2411.2.2 (310.2.2) Size and material of jumper.** The bonding jumper shall be not smaller than 6 AWG copper wire or equivalent.~~

~~**G2411.2.3 (310.2.3) Bonding jumper length.** The length of the bonding jumper between the connection to a gas piping system and the connection to a grounding electrode system shall not exceed 75 feet (22 860 mm). Any additional grounding electrodes installed to meet this requirement shall be bonded to the electrical service grounding electrode system or, where provided, the lightning protection grounding electrode system.~~

~~**G2411.2.4 (310.2.4) Bonding connections.** Bonding connections shall be in accordance with NFPA 70.~~

~~**G2411.2.5 (310.2.5) Connection devices.** Devices used for making the bonding connections shall be listed for the application in accordance with UL 467.~~

~~**G2411.3 (310.3) Arc-resistant CSST.** This section applies to corrugated stainless steel tubing (CSST) that is listed with an arc-resistant jacket or coating system in accordance with ANSI LCI/CSA 6.26. The CSST shall be electrically continuous and bonded to an effective ground-fault current path. Where any CSST component of a piping system does not have an arc-resistant jacket or coating system, the bonding requirements of Section G2411.2 shall apply. Arc-resistant jacketed CSST shall be considered to be bonded where it is connected to an appliance that is connected to the appliance grounding conductor of the circuit that supplies that appliance.~~

G2411.1 Gas pipe bonding. Electrical bonding of gas piping systems shall be in accordance with the [Electrical Code](#).

SECTION G2412 ~~(401)~~

GENERAL

G2412.1 ~~(401.1)~~ Scope. This section shall govern the design, installation, ~~and~~ modification ~~and maintenance~~ of *pipng systems*. The applicability of this *code* to *pipng systems* extends from the *point of delivery* to the connections with the *appliances* and includes the design, materials, components, fabrication, assembly, installation, testing, ~~and~~ inspection, ~~operation and maintenance~~ of such *pipng systems*.

G2412.1.1 ~~(401.1.1)~~ Utility piping systems located within buildings. Utility service *pipng* located within buildings shall be installed in accordance with the structural safety and fire protection provisions of this code.

G2412.2 ~~(401.2)~~ Liquefied petroleum gas storage. The storage system for *liquefied petroleum gas* is not regulated by this code. ~~shall be designed and installed in accordance with the International Fire Code and NFPA 58.~~

Notice of Installation. “Notice of Installation” is required by the State Fire Marshal for all LP-gas tank installations. For installation requirements of LP-gas tanks and tubing or piping up to the first-stage regulator, contact the office of the State Fire Marshal.

G2412.3 ~~(401.3)~~ Modifications to existing systems. In modifying or adding to existing *pipng systems*, sizes shall be maintained in accordance with this chapter.

G2412.4 ~~(401.4)~~ Additional appliances. Where an additional *appliance* is to be served, the existing *pipng* shall be checked to determine if it has adequate capacity for all *appliances* served. If inadequate, the existing system shall be enlarged as required or separate *pipng* of adequate capacity shall be provided.

G2412.5 ~~(401.5)~~ Identification. For other than steel *pipe* and CSST, exposed *pipng* shall be identified by a yellow label marked “Gas” in black letters. The marking shall be spaced at intervals not exceeding 5 feet (1524 mm). The marking shall not be required on *pipng* located in the same *room* as the *appliance* served. CSST shall be identified as required by ANSI LC1/CSA 6.26.

G2412.6 ~~(401.6)~~ Interconnections. Where two or more *meters* are installed on the same premises but supply separate consumers, the *pipng systems* shall not be interconnected on the outlet side of the *meters*.

G2412.7 ~~(401.7)~~ Piping meter identification. *Pipng* from multiple *meter* installations shall be marked with an *approved* permanent identification by the installer so that the *pipng system* supplied by each *meter* is readily identifiable.

G2412.8 ~~(401.8)~~ Minimum sizes. *Pipe* utilized for the installation, extension and *alteration* of any *pipng system* shall be sized to supply the full number of outlets for the intended purpose and shall be sized in accordance with Section G2413.

G2412.9 ~~(401.9)~~ Identification. Each length of pipe and tubing ~~and each pipe fitting~~, utilized in a fuel gas system shall bear the identification of the manufacturer.

Exceptions:

1. Steel pipe sections that are 2 feet (610 mm) and less in length and are cut from longer sections of pipe.
2. Steel pipe fittings 2 inches and less in size.
3. Where identification is provided on the product packaging or crating.
4. Where other approved documentation is provided.

G2412.10 ~~(401.10)~~ Piping materials standards. Piping, ~~and tubing and fittings~~ shall be manufactured to the applicable referenced standards, specifications and performance criteria listed in Section G2414 and shall be identified in accordance with Section G2412.9.

SECTION G2413 ~~(402)~~

PIPE SIZING

G2413.1 ~~(402.1)~~ General considerations. *Pipng systems* shall be of such size and so installed as to provide a supply of gas sufficient to meet the maximum *demand* and supply gas to each *appliance* inlet at not less than the minimum supply pressure required by the *appliance*.

G2413.2 ~~(402.2)~~ Maximum gas demand. The volumetric flow rate of gas to be provided shall be the sum of the maximum input of the *appliances* served.

The total connected hourly load shall be used as the basis for pipe sizing, assuming that all appliances could be operating at full capacity simultaneously. Where a diversity of load can be established, pipe sizing shall be permitted to be based on such loads.

The volumetric flow rate of gas to be provided shall be adjusted for altitude where the installation is above 2,000 feet (610 m) in elevation.

G2413.3 ~~(402.3)~~ Sizing. *Gas pipng* shall be sized in accordance with one of the following:

1. *Pipe* sizing tables or sizing equations in accordance with Section G2413.4 or G2413.5, as applicable.
2. The sizing tables included in a *listed pipng* system’s manufacturer’s installation instructions.
3. *Approved engineering* methods.

G2413.4 ~~(402.4)~~ Sizing tables and equations. This section applies to piping materials other than noncorrugated stainless steel tubing. Where Tables G2413.4(1) through G2413.4(21) are used to size *pipng* or *tubing*, the *pipe* length shall be determined in accordance with Section G2413.4.1, G2413.4.2 or G2413.4.3.

Where Equations 24-3 and 24-4 are used to size *pipng* or *tubing*, the *pipe* or *tubing* shall have smooth inside walls and the pipe length shall be determined in accordance with Section G2413.4.1, G2413.4.2 or G2413.4.3.

1. Low-pressure gas equation [Less than 1¹/₂ square inch (psi) (10.3 kPa)]: **(Equation 24-3)**
2. High-pressure gas equation [1¹/₂ psi (10.3 kPa and above)]: **(Equation 24-4)**

D = Inside diameter of *pipe*, inches (mm).

Q = Input rate *appliance(s)*, cubic feet per hour at 60°F (16°C) and 30-inch mercury column.

*P*₁ = Upstream pressure, psia (*P*₁ + 14.7).

*P*₂ = Downstream pressure, psia (*P*₂ + 14.7).

L = Equivalent length of *pipe*, feet.

ΔH = *Pressure drop*, inch water column (27.7-inch water column = 1 psi).

**TABLE G2413.4 (402.4)
C_r AND Y VALUES FOR NATURAL GAS AND
UNDILUTED PROPANE AT STANDARD CONDITIONS**

GAS	EQUATION FACTORS	
	C _r	Y
Natural gas	0.6094	0.9992
Undiluted propane	1.2462	0.9910

For SI: 1 cubic foot = 0.028 m³, 1 foot = 305 mm,
1-inch water column = 0.249 kPa,
1 pound per square inch = 6.895 kPa,
1 British thermal unit per hour = 0.293 W.

G2413.4.1 (402.4.1) Longest length method. The *pipe* size of each section of *gas piping* shall be determined using the longest length of *pipng* from the *point of delivery* to the most remote *outlet* and the load of the section.

G2413.4.2 (402.4.2) Branch length method. *Pipe* shall be sized as follows:

1. *Pipe* size of each section of the longest *pipe* run from the *point of delivery* to the most remote *outlet* shall be determined using the longest run of *pipng* and the load of the section.
2. The *pipe* size of each section of branch *pipng* not previously sized shall be determined using the length of *pipng* from the *point of delivery* to the most remote *outlet* in each branch and the load of the section.

G2413.4.3 (402.4.3) Hybrid pressure. The *pipe* size for each section of higher pressure *gas piping* shall be determined using the longest length of *pipng* from the *point of delivery* to the most remote line *pressure regulator*. The *pipe* size from the line *pressure regulator* to each *outlet* shall be determined using the length of *pipng* from the *regulator* to the most remote outlet served by the *regulator*.

G2413.5 (402.5) Noncorrugated stainless steel tubing. Noncorrugated stainless steel tubing shall be sized in accordance with Equations 24-3 and 24-4 of Section 2413.4 in conjunction with Section 2413.4.1, 2413.4.2 or 2413.4.3.

G2413.6 (402.6) Allowable pressure drop. The design pressure loss in any *pipng system* under maximum **demand**, from the *point of delivery* to the inlet connection of **all appliances served**, shall be such that the supply pressure at **each appliance inlet** is greater than or equal to the minimum pressure required by the *appliance*.

G2413.7 (402.7) Maximum operating pressure. The maximum design operating pressure for *pipng systems* located inside buildings shall not exceed 5 pounds per square inch gauge (psig) (34 kPa gauge) except where one or more of the following conditions are met:

1. The *pipng joints* are welded or brazed.
2. The *pipng* is joined by fittings **listed to ANSI LC4/CSA 6.32 and installed in accordance with the manufacturer’s instructions.**
3. The *pipng joints* are flanged and pipe-to-flange connections are made by welding or brazing.
4. The *pipng* is located in a ventilated chase or otherwise enclosed for protection against accidental gas accumulation.
5. The *pipng* is a temporary installation for buildings under construction.

G2413.7.1 (402.7.1) Operation below -5°F (-21°C). LP-gas systems designed to operate below -5°F (-21°C) or with butane or a propane-butane mix shall be designed to either accommodate liquid LP-gas or prevent LP-gas vapor from condensing into a liquid.

[License requirements. LP-gas installers must be licensed by the State Fire Marshal in accordance with ORS 480.432 through 480.436.](#)

**SECTION G2414 (403)
PIPING MATERIALS**

G2414.1 (403.1) General. Materials used for *pipng systems* shall comply with the requirements of this chapter or shall be *approved*.

G2414.2 (403.2) Used materials. *Pipe*, fittings, *valves* or other materials shall not be used again unless they are free from foreign materials and have been ascertained to be adequate for the service intended.

G2414.3 (403.3) Metallic pipe. Metallic *pipe* shall comply with Sections G2414.3.1 and G2414.3.2.

G2414.3.1 (403.3.1) Cast iron. Cast-iron *pipe* shall not be used.

G2414.3.2 (403.3.2) Steel. Steel, stainless Steel and wrought-iron *pipe* shall not be lighter than Schedule 10 and shall comply with the dimensional standards of ASME B36.10M and one of

the following standards:

1. ASTM A53/A53M.
2. ASTM A106.
3. ASTM A312.

G2414.4 (403.4) Metallic tubing. *Tubing* shall not be used with gases corrosive to the tubing material.

G2414.4.1 (403.4.1) Steel tubing. Steel *tubing* shall comply with ASTM A254.

G2414.4.2 (403.4.2) Stainless steel. Stainless steel tubing shall comply with ASTM A268 or ASTM A269.

G2414.4.3 (403.4.3) Copper or copper -alloy tubing. Copper *tubing* shall comply with Standard Type K or L of ASTM B88 or ASTM B280.

Copper and copper -alloy *tubing* shall not be used if the gas contains more than an average of 0.3 grains of hydrogen sulfide per 100 standard cubic feet of gas (0.7 milligrams per 100 liters).

G2414.4.4 (403.4.5) Corrugated stainless steel tubing. Corrugated stainless steel *tubing* shall be *listed* in accordance with ANSI LC1/CSA 6.26.

G2414.5 (403.6) Plastic pipe, tubing and fittings. Polyethylene plastic pipe, tubing and fittings used to supply fuel gas shall conform to ASTM D2513. Such pipe shall be marked “Gas” and “ASTM D2513.”

Polyamide pipe, tubing and fittings shall be identified and conform to ASTM F2945. Such pipe shall be marked “Gas” and “ASTM F2945.”

Polyvinyl chloride (PVC) and chlorinated polyvinyl chloride (CPVC) plastic pipe, tubing and fittings shall not be used to supply fuel gas.

G2414.5.1 (403.5.1) Anodeless risers. Plastic pipe, tubing and anodeless risers shall comply with the following:

1. Factory-assembled anodeless risers shall be recommended by the manufacturer for the gas used and shall be leak tested by the manufacturer in accordance with written procedures.
2. Service head adapters and field-assembled anodeless risers incorporating service head adapters shall be recommended by the manufacturer for the gas used, and shall be designed and certified to meet the requirements of Category I of ASTM D2513, and US Department of Transportation, Code of Federal Regulations, Title 49 CFR, Part 192.281(e). The manufacturer shall provide the user with qualified installation instructions as prescribed by the US Department of Transportation, Code of Federal Regulations, Title 49 CFR, Part 192.283(b).

G2414.5.2 (403.5.2) LP-gas systems. The use of plastic pipe, tubing and fittings in undiluted liquefied petroleum gas *piping* systems shall be in accordance with NFPA 58.

G2414.6.3 (403.6.3) Regulator vent piping. Plastic pipe and fittings used to connect *regulator* vents to remote vent terminations shall be of PVC conforming to ANSI/UL 651. PVC vent *piping* shall not be installed indoors.

G2414.7 (403.7) Workmanship and defects. *Pipe, tubing* and fittings shall be clear and free from cutting burrs and defects in structure or threading, and shall be thoroughly brushed, and chip and scale blown.

Defects in *pipe, tubing* and fittings shall not be repaired. Defective *pipe, tubing* and fittings shall be replaced. (See Section G2417.1.2.)

G2414.8 (403.8) Protective coating. Where in contact with material or atmosphere exerting a corrosive action, metallic *piping* and fittings coated with a corrosion-resistant material shall be used. External or internal coatings or linings used on *piping* or components shall not be considered as adding strength.

G2414.9 (403.9) Metallic pipe threads. Metallic *pipe* and fitting threads shall be taper *pipe* threads and shall comply with ASME B1.20.1.

G2414.8.1 (403.8.1) Damaged threads. *Pipe* with threads that are stripped, chipped, corroded or otherwise damaged shall not be used. Where a weld opens during the operation of cutting or threading, that portion of the *pipe* shall not be used.

G2414.8.2 (403.8.2) Number of threads. Field threading of metallic *pipe* shall be in accordance with Table G2414.8.2.

TABLE G2414.8.2 (403.8.2) SPECIFICATIONS FOR THREADING METALLIC PIPE

IRON PIPE SIZE (inches)	APPROXIMATE LENGTH OF THREADED PORTION (inches)	APPROXIMATE NO. OF THREADS TO BE CUT
1/2	3/4	10
3/4	3/4	10
1	7/8	10
1 1/4	1	11
1 1/2	1	11

For SI: 1 inch = 25.4 mm.

G2414.8.3 (403.8.3) Threaded joint sealing. Threaded joints shall be made using a Thread joint sealing material. Thread joint sealing materials shall be nonhardening and shall be resistant to the chemical constituents of the gases to be conveyed through the *piping*. Thread joint sealing materials shall be compatible with the pipe and fitting materials on which the sealing materials are used.

G2414.9 ~~(403.9)~~ Metallic piping joints and fittings. The type of *piping* joint used shall be suitable for the pressure-temperature conditions and shall be selected giving consideration to joint tightness and mechanical strength under the service conditions. The joint shall be able to sustain the maximum end force caused by the internal pressure and any additional forces caused by temperature expansion or contraction, vibration, fatigue, or to the weight of the *pipe* and its contents.

G2414.9.1 ~~(403.9.1)~~ Pipe joints. Schedule 40 and heavier *Pipe* joints shall be threaded, flanged, brazed, welded or assembled with press-connect fittings listed in accordance with ANSI LC4/CSA 6.32. Pipe lighter than Schedule 40 shall be connected using press-connect fittings, flanges, brazing or welding. Where nonferrous *pipe* is brazed, the *brazing* materials shall have a melting point in excess of 1,000°F (538°C). *Brazing* alloys shall not contain more than 0.05-percent phosphorus.

G2414.9.2 ~~(403.9.2)~~ Copper Tubing joints. Copper *Tubing* joints shall be assembled with *approved gas tubing* fittings, shall be brazed with a material having a melting point in excess of 1,000°F (538°C) or assembled with press-connect fittings listed in accordance with ANSI LC4/CSA 6.32. *Brazing alloys* shall not contain more than 0.05-percent phosphorus.

G2414.9.3 ~~(403.9.3)~~ Stainless steel tubing joints. Stainless steel tubing joints shall be welded, assembled with approved tubing fittings, brazed with a material having a melting point in excess of 1,000°F (538°C), or assembled with press-connect fittings listed in accordance with ANSI LC4/CSA 6.32.

G2414.9.4 ~~(403.10.4)~~ Flared joints. *Flared joints* shall be used only in systems constructed from nonferrous *pipe* and *tubing* where experience or tests have demonstrated that the joint is suitable for the conditions and where provisions are made in the design to prevent separation of the joints.

G2414.9.5 ~~(403.9.5)~~ Metallic fittings. Metallic fittings shall comply with the following:

1. Fittings used with steel, stainless steel or wrought-iron *pipe* shall be steel, stainless steel, copper alloy, malleable iron or cast iron.
2. Fittings used with copper or copper alloy *pipe* shall be copper or copper alloy.
3. Cast-iron bushings shall be prohibited.
4. Special fittings. Fittings such as couplings, proprietary-type joints, saddle tees, gland-type compression fittings, and flared, flareless and compression-type *tubing* fittings shall be: used within the fitting manufacturer's pressure-temperature recommendations; used within the service conditions anticipated with respect to vibration, fatigue, thermal expansion and contraction; and shall be *approved*.

5. Where pipe fittings are drilled and tapped in the field, the operation shall be in accordance with all of the following:
 - 5.1. The operation shall be performed on systems having operating pressures of 5 psi (34.5 kPa) or less.
 - 5.2. The operation shall be performed by the gas supplier or the gas supplier's designated representative.
 - 5.3. The drilling and tapping operation shall be performed in accordance with written procedures prepared by the gas supplier.
 - 5.4. The fittings shall be located outdoors.
 - 5.5. The tapped fitting assembly shall be inspected and proven to be free of leakage.

G2414.10 ~~(403.10)~~ Plastic piping, joints and fittings. Plastic *pipe, tubing* and fittings shall be joined in accordance with the manufacturers' instructions. Such joints shall comply with the following:

1. The joints shall be designed and installed so that the longitudinal pull-out resistance of the joint will be greater than or equal to the tensile strength of the plastic *piping* material.
2. Heat-fusion joints shall be made in accordance with qualified procedures that have been established and proven by test to produce gastight joints as strong as or stronger than the *pipe* or *tubing* being joined. Joints shall be made with the joining method recommended by the *pipe* manufacturer. Polyethylene Heat fusion fittings shall be marked "ASTM D2513." Polyamide heat fusion fittings shall be marked "ASTM F2945."
3. Where compression-type *mechanical joints* are used, the gasket material in the fitting shall be compatible with the plastic *piping* and with the gas distributed by the system. An internal tubular rigid stiffener shall be used in conjunction with the fitting. The stiffener shall be flush with the end of the *pipe* or *tubing* and shall extend to or beyond the outside end of the compression fitting when installed. The stiffener shall be free of rough or sharp edges and shall not be a force -fit in the plastic. Split tubular stiffeners shall not be used.
4. Plastic *piping* joints and fittings for use in *liquefied petroleum gas piping systems* shall be in accordance with NFPA 58.

**TABLE G2413.4(1) [402.4(2)]
SCHEDULE 40 METALLIC PIPE**

Gas	Natural
Inlet Pressure	Less than 2 psi
Pressure Drop	0.5 in. w.c.
Specific Gravity	0.60

PIPE SIZE (inches)														
Nominal	1/2	3/4	1	1 1/4	1 1/2	2	2 1/2	3	4	5	6	8	10	12
Actual ID	0.622	0.824	1.049	1.380	1.610	2.067	2.469	3.068	4.026	5.047	6.065	7.981	10.020	11.938
Length (ft)	Capacity in Cubic Feet of Gas per Hour													
10	172	360	678	1,390	2,090	4,020	6,400	11,300	23,100	41,800	67,600	139,000	252,000	399,000
20	118	247	466	957	1,430	2,760	4,400	7,780	15,900	28,700	46,500	95,500	173,000	275,000
30	95	199	374	768	1,150	2,220	3,530	6,250	12,700	23,000	37,300	76,700	139,000	220,000
40	81	170	320	657	985	1,900	3,020	5,350	10,900	19,700	31,900	65,600	119,000	189,000
50	72	151	284	583	873	1,680	2,680	4,740	9,660	17,500	28,300	58,200	106,000	167,000
60	65	137	257	528	791	1,520	2,430	4,290	8,760	15,800	25,600	52,700	95,700	152,000
70	60	126	237	486	728	1,400	2,230	3,950	8,050	14,600	23,600	48,500	88,100	139,000
80	56	117	220	452	677	1,300	2,080	3,670	7,490	13,600	22,000	45,100	81,900	130,000
90	52	110	207	424	635	1,220	1,950	3,450	7,030	12,700	20,600	42,300	76,900	122,000
100	50	104	195	400	600	1,160	1,840	3,260	6,640	12,000	19,500	40,000	72,600	115,000
125	44	92	173	355	532	1,020	1,630	2,890	5,890	10,600	17,200	35,400	64,300	102,000
150	40	83	157	322	482	928	1,480	2,610	5,330	9,650	15,600	32,100	58,300	92,300
175	37	77	144	296	443	854	1,360	2,410	4,910	8,880	14,400	29,500	53,600	84,900
200	34	71	134	275	412	794	1,270	2,240	4,560	8,260	13,400	27,500	49,900	79,000
250	30	63	119	244	366	704	1,120	1,980	4,050	7,320	11,900	24,300	44,200	70,000
300	27	57	108	221	331	638	1,020	1,800	3,670	6,630	10,700	22,100	40,100	63,400
350	25	53	99	203	305	587	935	1,650	3,370	6,100	9,880	20,300	36,900	58,400
400	23	49	92	189	283	546	870	1,540	3,140	5,680	9,190	18,900	34,300	54,300
450	22	46	86	177	266	512	816	1,440	2,940	5,330	8,620	17,700	32,200	50,900
500	21	43	82	168	251	484	771	1,360	2,780	5,030	8,150	16,700	30,400	48,100
550	20	41	78	159	239	459	732	1,290	2,640	4,780	7,740	15,900	28,900	45,700
600	19	39	74	152	228	438	699	1,240	2,520	4,560	7,380	15,200	27,500	43,600
650	18	38	71	145	218	420	669	1,180	2,410	4,360	7,070	14,500	26,400	41,800
700	17	36	68	140	209	403	643	1,140	2,320	4,190	6,790	14,000	25,300	40,100
750	17	35	66	135	202	389	619	1,090	2,230	4,040	6,540	13,400	24,400	38,600
800	16	34	63	130	195	375	598	1,060	2,160	3,900	6,320	13,000	23,600	37,300
850	16	33	61	126	189	363	579	1,020	2,090	3,780	6,110	12,600	22,800	36,100
900	15	32	59	122	183	352	561	992	2,020	3,660	5,930	12,200	22,100	35,000
950	15	31	58	118	178	342	545	963	1,960	3,550	5,760	11,800	21,500	34,000
1,000	14	30	56	115	173	333	530	937	1,910	3,460	5,600	11,500	20,900	33,100
1,100	14	28	53	109	164	316	503	890	1,810	3,280	5,320	10,900	19,800	31,400
1,200	13	27	51	104	156	301	480	849	1,730	3,130	5,070	10,400	18,900	30,000
1,300	12	26	49	100	150	289	460	813	1,660	3,000	4,860	9,980	18,100	28,700
1,400	12	25	47	96	144	277	442	781	1,590	2,880	4,670	9,590	17,400	27,600
1,500	11	24	45	93	139	267	426	752	1,530	2,780	4,500	9,240	16,800	26,600
1,600	11	23	44	89	134	258	411	727	1,480	2,680	4,340	8,920	16,200	25,600
1,700	11	22	42	86	130	250	398	703	1,430	2,590	4,200	8,630	15,700	24,800
1,800	10	22	41	84	126	242	386	682	1,390	2,520	4,070	8,370	15,200	24,100
1,900	10	21	40	81	122	235	375	662	1,350	2,440	3,960	8,130	14,800	23,400
2,000	NA	20	39	79	119	229	364	644	1,310	2,380	3,850	7,910	14,400	22,700

For SI: 1 inch = 25.4 mm, 1 foot = 304.8 mm, 1 pound per square inch = 6.895 kPa, 1-inch water column = 0.2488 kPa, 1 British thermal unit per hour = 0.2931 W, 1 cubic foot per hour = 0.0283 m³/h, 1 degree = 0.01745 rad.

Notes:

1. NA means a flow of less than 10 cfh.
2. Table entries have been rounded to three significant digits.

TABLE G2413.4(2) [402.4(5)]
SCHEDULE 40 METALLIC PIPE

Gas	Natural
Inlet Pressure	2.0 psi
Pressure Drop	1.0 psi
Specific Gravity	0.60

PIPE SIZE (inches)									
Nominal	1/2	3/4	1	1 1/4	1 1/2	2	2 1/2	3	4
Actual ID	0.622	0.824	1.049	1.380	1.610	2.067	2.469	3.068	4.026
Length (ft)	Capacity in Cubic Feet of Gas per Hour								
10	1,510	3,040	5,560	11,400	17,100	32,900	52,500	92,800	189,000
20	1,070	2,150	3,930	8,070	12,100	23,300	37,100	65,600	134,000
30	869	1,760	3,210	6,590	9,880	19,000	30,300	53,600	109,000
40	753	1,520	2,780	5,710	8,550	16,500	26,300	46,400	94,700
50	673	1,360	2,490	5,110	7,650	14,700	23,500	41,500	84,700
60	615	1,240	2,270	4,660	6,980	13,500	21,400	37,900	77,300
70	569	1,150	2,100	4,320	6,470	12,500	19,900	35,100	71,600
80	532	1,080	1,970	4,040	6,050	11,700	18,600	32,800	67,000
90	502	1,010	1,850	3,810	5,700	11,000	17,500	30,900	63,100
100	462	934	1,710	3,510	5,260	10,100	16,100	28,500	58,200
125	414	836	1,530	3,140	4,700	9,060	14,400	25,500	52,100
150	372	751	1,370	2,820	4,220	8,130	13,000	22,900	46,700
175	344	695	1,270	2,601	3,910	7,530	12,000	21,200	43,300
200	318	642	1,170	2,410	3,610	6,960	11,100	19,600	40,000
250	279	583	1,040	2,140	3,210	6,180	9,850	17,400	35,500
300	253	528	945	1,940	2,910	5,600	8,920	15,800	32,200
350	232	486	869	1,790	2,670	5,150	8,210	14,500	29,600
400	216	452	809	1,660	2,490	4,790	7,640	13,500	27,500
450	203	424	759	1,560	2,330	4,500	7,170	12,700	25,800
500	192	401	717	1,470	2,210	4,250	6,770	12,000	24,400
550	182	381	681	1,400	2,090	4,030	6,430	11,400	23,200
600	174	363	650	1,330	2,000	3,850	6,130	10,800	22,100
650	166	348	622	1,280	1,910	3,680	5,870	10,400	21,200
700	160	334	598	1,230	1,840	3,540	5,640	9,970	20,300
750	154	322	576	1,180	1,770	3,410	5,440	9,610	19,600
800	149	311	556	1,140	1,710	3,290	5,250	9,280	18,900
850	144	301	538	1,100	1,650	3,190	5,080	8,980	18,300
900	139	292	522	1,070	1,600	3,090	4,930	8,710	17,800
950	135	283	507	1,040	1,560	3,000	4,780	8,460	17,200
1,000	132	275	493	1,010	1,520	2,920	4,650	8,220	16,800
1,100	125	262	468	960	1,440	2,770	4,420	7,810	15,900
1,200	119	250	446	917	1,370	2,640	4,220	7,450	15,200
1,300	114	239	427	878	1,320	2,530	4,040	7,140	14,600
1,400	110	230	411	843	1,260	2,430	3,880	6,860	14,000
1,500	106	221	396	812	1,220	2,340	3,740	6,600	13,500
1,600	102	214	382	784	1,180	2,260	3,610	6,380	13,000
1,700	99	207	370	759	1,140	2,190	3,490	6,170	12,600
1,800	96	200	358	736	1,100	2,120	3,390	5,980	12,200
1,900	93	195	348	715	1,070	2,060	3,290	5,810	11,900
2,000	91	189	339	695	1,040	2,010	3,200	5,650	11,500

For SI: 1 inch = 25.4 mm, 1 foot = 304.8 mm, 1 pound per square inch = 6.895 kPa, 1-inch water column = 0.2488 kPa, 1 British thermal unit per hour = 0.2931 W, 1 cubic foot per hour = 0.0283 m³/h, 1 degree = 0.01745 rad.

Note: Table entries have been rounded to three significant digits.

**TABLE G2413.4(3) [402.4(9)]
SEMIRIGID COPPER TUBING**

Gas	Natural
Inlet Pressure	Less than 2 psi
Pressure Drop	0.5 in. w.c.
Specific Gravity	0.60

TUBE SIZE (inches)										
Nominal	K & L	1/4	3/8	1/2	5/8	3/4	1	1 1/4	1 1/2	2
	ACR	3/8	1/2	5/8	3/4	7/8	1 1/8	1 3/8	—	—
Outside		0.375	0.500	0.625	0.750	0.875	1.125	1.375	1.625	2.125
Inside		0.305	0.402	0.527	0.652	0.745	0.995	1.245	1.481	1.959
Length (ft)	Capacity in Cubic Feet of Gas per Hour									
10	27	55	111	195	276	590	1,060	1,680	3,490	
20	18	38	77	134	190	406	730	1,150	2,400	
30	15	30	61	107	152	326	586	925	1,930	
40	13	26	53	92	131	279	502	791	1,650	
50	11	23	47	82	116	247	445	701	1,460	
60	10	21	42	74	105	224	403	635	1,320	
70	NA	19	39	68	96	206	371	585	1,220	
80	NA	18	36	63	90	192	345	544	1,130	
90	NA	17	34	59	84	180	324	510	1,060	
100	NA	16	32	56	79	170	306	482	1,000	
125	NA	14	28	50	70	151	271	427	890	
150	NA	13	26	45	64	136	245	387	806	
175	NA	12	24	41	59	125	226	356	742	
200	NA	11	22	39	55	117	210	331	690	
250	NA	NA	20	34	48	103	186	294	612	
300	NA	NA	18	31	44	94	169	266	554	
350	NA	NA	16	28	40	86	155	245	510	
400	NA	NA	15	26	38	80	144	228	474	
450	NA	NA	14	25	35	75	135	214	445	
500	NA	NA	13	23	33	71	128	202	420	
550	NA	NA	13	22	32	68	122	192	399	
600	NA	NA	12	21	30	64	116	183	381	
650	NA	NA	12	20	29	62	111	175	365	
700	NA	NA	11	20	28	59	107	168	350	
750	NA	NA	11	19	27	57	103	162	338	
800	NA	NA	10	18	26	55	99	156	326	
850	NA	NA	10	18	25	53	96	151	315	
900	NA	NA	NA	17	24	52	93	147	306	
950	NA	NA	NA	17	24	50	90	143	297	
1,000	NA	NA	NA	16	23	49	88	139	289	
1,100	NA	NA	NA	15	22	46	84	132	274	
1,200	NA	NA	NA	15	21	44	80	126	262	
1,300	NA	NA	NA	14	20	42	76	120	251	
1,400	NA	NA	NA	13	19	41	73	116	241	
1,500	NA	NA	NA	13	18	39	71	111	232	
1,600	NA	NA	NA	13	18	38	68	108	224	
1,700	NA	NA	NA	12	17	37	66	104	217	
1,800	NA	NA	NA	12	17	36	64	101	210	
1,900	NA	NA	NA	11	16	35	62	98	204	
2,000	NA	NA	NA	11	16	34	60	95	199	

For SI: 1 inch = 25.4 mm, 1 foot = 304.8 mm, 1 pound per square inch = 6.895 kPa, 1-inch water column = 0.2488 kPa, 1 British thermal unit per hour = 0.2931 W, 1 cubic foot per hour = 0.0283 m³/h, 1 degree = 0.01745 rad.

Notes:

1. Table capacities are based on Type K copper tubing inside diameter (shown), which has the smallest inside diameter of the copper tubing products.
2. NA means a flow of less than 10 cfh.
3. Table entries have been rounded to three significant digits.

**TABLE G2413.4(4) [402.4(12)]
SEMIRIGID COPPER TUBING**

Gas	Natural
Inlet Pressure	2.0 psi
Pressure Drop	1.0 psi
Specific Gravity	0.60

TUBE SIZE (inches)										
Nominal	K & L	1/4	3/8	1/2	5/8	3/4	1	1 1/4	1 1/2	2
	ACR	3/8	1/2	5/8	3/4	7/8	1 1/8	1 3/8	—	—
Outside		0.375	0.500	0.625	0.750	0.875	1.125	1.375	1.625	2.125
Inside		0.305	0.402	0.527	0.652	0.745	0.995	1.245	1.481	1.959
Length (ft)		Capacity in Cubic Feet of Gas per Hour								
10	245	506	1,030	1,800	2,550	5,450	9,820	15,500	32,200	
20	169	348	708	1,240	1,760	3,750	6,750	10,600	22,200	
30	135	279	568	993	1,410	3,010	5,420	8,550	17,800	
40	116	239	486	850	1,210	2,580	4,640	7,310	15,200	
50	103	212	431	754	1,070	2,280	4,110	6,480	13,500	
60	93	192	391	683	969	2,070	3,730	5,870	12,200	
70	86	177	359	628	891	1,900	3,430	5,400	11,300	
80	80	164	334	584	829	1,770	3,190	5,030	10,500	
90	75	154	314	548	778	1,660	2,990	4,720	9,820	
100	71	146	296	518	735	1,570	2,830	4,450	9,280	
125	63	129	263	459	651	1,390	2,500	3,950	8,220	
150	57	117	238	416	590	1,260	2,270	3,580	7,450	
175	52	108	219	383	543	1,160	2,090	3,290	6,850	
200	49	100	204	356	505	1,080	1,940	3,060	6,380	
250	43	89	181	315	448	956	1,720	2,710	5,650	
300	39	80	164	286	406	866	1,560	2,460	5,120	
350	36	74	150	263	373	797	1,430	2,260	4,710	
400	33	69	140	245	347	741	1,330	2,100	4,380	
450	31	65	131	230	326	696	1,250	1,970	4,110	
500	30	61	124	217	308	657	1,180	1,870	3,880	
550	28	58	118	206	292	624	1,120	1,770	3,690	
600	27	55	112	196	279	595	1,070	1,690	3,520	
650	26	53	108	188	267	570	1,030	1,620	3,370	
700	25	51	103	181	256	548	986	1,550	3,240	
750	24	49	100	174	247	528	950	1,500	3,120	
800	23	47	96	168	239	510	917	1,450	3,010	
850	22	46	93	163	231	493	888	1,400	2,920	
900	22	44	90	158	224	478	861	1,360	2,830	
950	21	43	88	153	217	464	836	1,320	2,740	
1,000	20	42	85	149	211	452	813	1,280	2,670	
1,100	19	40	81	142	201	429	772	1,220	2,540	
1,200	18	38	77	135	192	409	737	1,160	2,420	
1,300	18	36	74	129	183	392	705	1,110	2,320	
1,400	17	35	71	124	176	376	678	1,070	2,230	
1,500	16	34	68	120	170	363	653	1,030	2,140	
1,600	16	33	66	116	164	350	630	994	2,070	
1,700	15	31	64	112	159	339	610	962	2,000	
1,800	15	30	62	108	154	329	592	933	1,940	
1,900	14	30	60	105	149	319	575	906	1,890	
2,000	14	29	59	102	145	310	559	881	1,830	

For SI: 1 inch = 25.4 mm, 1 foot = 304.8 mm, 1 pound per square inch = 6.895 kPa, 1-inch water column = 0.2488 kPa, 1 British thermal unit per hour = 0.2931 W, 1 cubic foot per hour = 0.0283 m³/h, 1 degree = 0.01745 rad.

Notes:

1. Table capacities are based on Type K copper tubing inside diameter (shown), which has the smallest inside diameter of the copper tubing products.
2. Table entries have been rounded to three significant digits.

Gas	Natural
Inlet Pressure	Less than 2 psi
Pressure Drop	0.5 in. w.c.

TABLE G2413.4(5) ~~[402.4(15)]~~
 CORRUGATED STAINLESS STEEL TUBING (CSST)

TUBE SIZE (EHD)														
Flow Designation	13	15	18	19	23	25	30	31	37	39	46	48	60	62
Length (ft)	Capacity in Cubic Feet of Gas per Hour													
5	46	63	115	134	225	270	471	546	895	1,037	1,790	2,070	3,660	4,140
10	32	44	82	95	161	192	330	383	639	746	1,260	1,470	2,600	2,930
15	25	35	66	77	132	157	267	310	524	615	1,030	1,200	2,140	2,400
20	22	31	58	67	116	137	231	269	456	536	888	1,050	1,850	2,080
25	19	27	52	60	104	122	206	240	409	482	793	936	1,660	1,860
30	18	25	47	55	96	112	188	218	374	442	723	856	1,520	1,700
40	15	21	41	47	83	97	162	188	325	386	625	742	1,320	1,470
50	13	19	37	42	75	87	144	168	292	347	559	665	1,180	1,320
60	12	17	34	38	68	80	131	153	267	318	509	608	1,080	1,200
70	11	16	31	36	63	74	121	141	248	295	471	563	1,000	1,110
80	10	15	29	33	60	69	113	132	232	277	440	527	940	1,040
90	10	14	28	32	57	65	107	125	219	262	415	498	887	983
100	9	13	26	30	54	62	101	118	208	249	393	472	843	933
150	7	10	20	23	42	48	78	91	171	205	320	387	691	762
200	6	9	18	21	38	44	71	82	148	179	277	336	600	661
250	5	8	16	19	34	39	63	74	133	161	247	301	538	591
300	5	7	15	17	32	36	57	67	95	148	226	275	492	540

For SI: 1 inch = 25.4 mm, 1 foot = 304.8 mm, 1 pound per square inch = 6.895 kPa, 1-inch water column = 0.2488 kPa, 1 British thermal unit per hour = 0.2931 W, 1 cubic foot per hour = 0.0283 m³/h, 1 degree = 0.01745 rad.

Notes:

1. Table includes losses for four 90-degree bends and two end fittings. Tubing runs with larger numbers of bends or fittings shall be increased by an equivalent length of tubing to the following equation: $L = 1.3n$, where L is additional length (feet) of tubing and n is the number of additional fittings or bends.
2. EHD—Equivalent Hydraulic Diameter, which is a measure of the relative hydraulic efficiency between different tubing sizes. The greater the value of EHD, the greater the gas capacity of the tubing.
3. Table entries have been rounded to three significant digits.

**TABLE G2413.4(6) [402.4(18)]
CORRUGATED STAINLESS STEEL TUBING (CSST)**

Gas	Natural
Inlet Pressure	2.0 psi
Pressure Drop	1.0 psi

TUBE SIZE (EHD)														
Flow Designation	13	15	18	19	23	25	30	31	37	39	46	48	60	62
Length (ft)	Capacity in Cubic Feet of Gas Per Hour													
10	270	353	587	700	1,100	1,370	2,590	2,990	4,510	5,037	9,600	10,700	18,600	21,600
25	166	220	374	444	709	876	1,620	1,870	2,890	3,258	6,040	6,780	11,900	13,700
30	151	200	342	405	650	801	1,480	1,700	2,640	2,987	5,510	6,200	10,900	12,500
40	129	172	297	351	567	696	1,270	1,470	2,300	2,605	4,760	5,380	9,440	10,900
50	115	154	266	314	510	624	1,140	1,310	2,060	2,343	4,260	4,820	8,470	9,720
75	93	124	218	257	420	512	922	1,070	1,690	1,932	3,470	3,950	6,940	7,940
80	89	120	211	249	407	496	892	1,030	1,640	1,874	3,360	3,820	6,730	7,690
100	79	107	189	222	366	445	795	920	1,470	1,685	3,000	3,420	6,030	6,880
150	64	87	155	182	302	364	646	748	1,210	1,389	2,440	2,800	4,940	5,620
200	55	75	135	157	263	317	557	645	1,050	1,212	2,110	2,430	4,290	4,870
250	49	67	121	141	236	284	497	576	941	1,090	1,890	2,180	3,850	4,360
300	44	61	110	129	217	260	453	525	862	999	1,720	1,990	3,520	3,980
400	38	52	96	111	189	225	390	453	749	871	1,490	1,730	3,060	3,450
500	34	46	86	100	170	202	348	404	552	783	1,330	1,550	2,740	3,090

For SI: 1 inch = 25.4 mm, 1 foot = 304.8 mm, 1 pound per square inch = 6.895 kPa, 1-inch water column = 0.2488 kPa, 1 British thermal unit per hour = 0.2931 W, 1 cubic foot per hour = 0.0283 m³/h, 1 degree = 0.01745 rad.

Notes:

1. Table does not include effect of pressure drop across the line regulator. Where regulator loss exceeds 3/4 psi, DO NOT USE THIS TABLE. Consult with the regulator manufacturer for pressure drops and capacity factors. Pressure drops across a regulator can vary with flow rate.
2. CAUTION: Capacities shown in the table might exceed maximum capacity for a selected regulator. Consult with the regulator or tubing manufacturer for guidance.
3. Table includes losses for four 90-degree bends and two end fittings. Tubing runs with larger numbers of bends or fittings shall be increased by an equivalent length of tubing to the following equation: $L = 1.3n$ where L is additional length (feet) of tubing and n is the number of additional fittings or bends.
4. EHD—Equivalent Hydraulic Diameter, which is a measure of the relative hydraulic efficiency between different tubing sizes. The greater the value of EHD, the greater the gas capacity of the tubing.
5. Table entries have been rounded to three significant digits.

TABLE G2413.4(7) ~~[402.4(21)]~~
 POLYETHYLENE PLASTIC PIPE

Gas	Natural
Inlet Pressure	Less than 2 psi
Pressure Drop	0.5 in. w.c.

PIPE SIZE (inches)						
Nominal OD	1/2	3/4	1	1 1/4	1 1/2	2
Designation	SDR 9	SDR 11	SDR 11	SDR 10	SDR 11	SDR 11
Actual ID	0.660	0.860	1.077	1.328	1.554	1.943
Length (ft)	Capacity in Cubic Feet of Gas per Hour					
10	201	403	726	1,260	1,900	3,410
20	138	277	499	865	1,310	2,350
30	111	222	401	695	1,050	1,880
40	95	190	343	594	898	1,610
50	84	169	304	527	796	1,430
60	76	153	276	477	721	1,300
70	70	140	254	439	663	1,190
80	65	131	236	409	617	1,110
90	61	123	221	383	579	1,040
100	58	116	209	362	547	983
125	51	103	185	321	485	871
150	46	93	168	291	439	789
175	43	86	154	268	404	726
200	40	80	144	249	376	675
250	35	71	127	221	333	598
300	32	64	115	200	302	542
350	29	59	106	184	278	499
400	27	55	99	171	258	464
450	26	51	93	160	242	435
500	24	48	88	152	229	411

For SI: 1 inch = 25.4 mm, 1 foot = 304.8 mm, 1 pound per square inch = 6.895 kPa, 1-inch water column = 0.2488 kPa, 1 British thermal unit per hour = 0.2931 W, 1 cubic foot per hour = 0.0283 m³/h, 1 degree = 0.01745 rad.
Note: Table entries have been rounded to three significant digits.

TABLE G2413.4(8) [402.4(22)]
POLYETHYLENE PLASTIC PIPE

Gas	Natural
Inlet Pressure	2.0 psi
Pressure Drop	1.0 psi

PIPE SIZE (inches)						
Nominal OD	1/2	3/4	1	1 1/4	1 1/2	2
Designation	SDR 9	SDR 11	SDR 11	SDR 10	SDR 11	SDR 11
Actual ID	0.660	0.860	1.077	1.328	1.554	1.943
Length (ft)	Capacity in Cubic Feet of Gas per Hour					
10	1,860	3,720	6,710	11,600	17,600	31,600
20	1,280	2,560	4,610	7,990	12,100	21,700
30	1,030	2,050	3,710	6,420	9,690	17,400
40	878	1,760	3,170	5,490	8,300	14,900
50	778	1,560	2,810	4,870	7,350	13,200
60	705	1,410	2,550	4,410	6,660	12,000
70	649	1,300	2,340	4,060	6,130	11,000
80	603	1,210	2,180	3,780	5,700	10,200
90	566	1,130	2,050	3,540	5,350	9,610
100	535	1,070	1,930	3,350	5,050	9,080
125	474	949	1,710	2,970	4,480	8,050
150	429	860	1,550	2,690	4,060	7,290
175	395	791	1,430	2,470	3,730	6,710
200	368	736	1,330	2,300	3,470	6,240
250	326	652	1,180	2,040	3,080	5,530
300	295	591	1,070	1,850	2,790	5,010
350	272	544	981	1,700	2,570	4,610
400	253	506	913	1,580	2,390	4,290
450	237	475	856	1,480	2,240	4,020
500	224	448	809	1,400	2,120	3,800
550	213	426	768	1,330	2,010	3,610
600	203	406	733	1,270	1,920	3,440
650	194	389	702	1,220	1,840	3,300
700	187	374	674	1,170	1,760	3,170
750	180	360	649	1,130	1,700	3,050
800	174	348	627	1,090	1,640	2,950
850	168	336	607	1,050	1,590	2,850
900	163	326	588	1,020	1,540	2,770
950	158	317	572	990	1,500	2,690
1,000	154	308	556	963	1,450	2,610
1,100	146	293	528	915	1,380	2,480
1,200	139	279	504	873	1,320	2,370
1,300	134	267	482	836	1,260	2,270
1,400	128	257	463	803	1,210	2,180
1,500	124	247	446	773	1,170	2,100
1,600	119	239	431	747	1,130	2,030
1,700	115	231	417	723	1,090	1,960
1,800	112	224	404	701	1,060	1,900
1,900	109	218	393	680	1,030	1,850
2,000	106	212	382	662	1,000	1,800

For SI: 1 inch = 25.4 mm, 1 foot = 304.8 mm, 1 pound per square inch = 6.895 kPa, 1-inch water column = 0.2488 kPa, 1 British thermal unit per hour = 0.2931 W, 1 cubic foot per hour = 0.0283 m³/h, 1 degree = 0.01745 rad.

Note: Table entries have been rounded to three significant digits.

TABLE G2413.4(9) [402.4(25)]
SCHEDULE 40 METALLIC PIPE

Gas	Undiluted Propane
Inlet Pressure	10.0 psi
Pressure Drop	1.0 psi

INTENDED USE	Pipe sizing between first stage (high-pressure regulator) and second stage (low-pressure regulator).								
PIPE SIZE (inches)									
Nominal	1/2	3/4	1	1 1/4	1 1/2	2	2 1/2	3	4
Actual ID	0.622	0.824	1.049	1.380	1.610	2.067	2.469	3.068	4.026
Length (ft)	Capacity in Thousands of Btu per Hour								
10	3,320	6,950	13,100	26,900	40,300	77,600	124,000	219,000	446,000
20	2,280	4,780	9,000	18,500	27,700	53,300	85,000	150,000	306,000
30	1,830	3,840	7,220	14,800	22,200	42,800	68,200	121,000	246,000
40	1,570	3,280	6,180	12,700	19,000	36,600	58,400	103,000	211,000
50	1,390	2,910	5,480	11,300	16,900	32,500	51,700	91,500	187,000
60	1,260	2,640	4,970	10,200	15,300	29,400	46,900	82,900	169,000
70	1,160	2,430	4,570	9,380	14,100	27,100	43,100	76,300	156,000
80	1,080	2,260	4,250	8,730	13,100	25,200	40,100	70,900	145,000
90	1,010	2,120	3,990	8,190	12,300	23,600	37,700	66,600	136,000
100	956	2,000	3,770	7,730	11,600	22,300	35,600	62,900	128,000
125	848	1,770	3,340	6,850	10,300	19,800	31,500	55,700	114,000
150	768	1,610	3,020	6,210	9,300	17,900	28,600	50,500	103,000
175	706	1,480	2,780	5,710	8,560	16,500	26,300	46,500	94,700
200	657	1,370	2,590	5,320	7,960	15,300	24,400	43,200	88,100
250	582	1,220	2,290	4,710	7,060	13,600	21,700	38,300	78,100
300	528	1,100	2,080	4,270	6,400	12,300	19,600	34,700	70,800
350	486	1,020	1,910	3,930	5,880	11,300	18,100	31,900	65,100
400	452	945	1,780	3,650	5,470	10,500	16,800	29,700	60,600
450	424	886	1,670	3,430	5,140	9,890	15,800	27,900	56,800
500	400	837	1,580	3,240	4,850	9,340	14,900	26,300	53,700
550	380	795	1,500	3,070	4,610	8,870	14,100	25,000	51,000
600	363	759	1,430	2,930	4,400	8,460	13,500	23,900	48,600
650	347	726	1,370	2,810	4,210	8,110	12,900	22,800	46,600
700	334	698	1,310	2,700	4,040	7,790	12,400	21,900	44,800
750	321	672	1,270	2,600	3,900	7,500	12,000	21,100	43,100
800	310	649	1,220	2,510	3,760	7,240	11,500	20,400	41,600
850	300	628	1,180	2,430	3,640	7,010	11,200	19,800	40,300
900	291	609	1,150	2,360	3,530	6,800	10,800	19,200	39,100
950	283	592	1,110	2,290	3,430	6,600	10,500	18,600	37,900
1,000	275	575	1,080	2,230	3,330	6,420	10,200	18,100	36,900
1,100	261	546	1,030	2,110	3,170	6,100	9,720	17,200	35,000
1,200	249	521	982	2,020	3,020	5,820	9,270	16,400	33,400
1,300	239	499	940	1,930	2,890	5,570	8,880	15,700	32,000
1,400	229	480	903	1,850	2,780	5,350	8,530	15,100	30,800
1,500	221	462	870	1,790	2,680	5,160	8,220	14,500	29,600
1,600	213	446	840	1,730	2,590	4,980	7,940	14,000	28,600
1,700	206	432	813	1,670	2,500	4,820	7,680	13,600	27,700
1,800	200	419	789	1,620	2,430	4,670	7,450	13,200	26,900
1,900	194	407	766	1,570	2,360	4,540	7,230	12,800	26,100
2,000	189	395	745	1,530	2,290	4,410	7,030	12,400	25,400

For SI: 1 inch = 25.4 mm, 1 foot = 304.8 mm, 1 pound per square inch = 6.895 kPa, 1-inch water column = 0.2488 kPa, 1 British thermal unit per hour = 0.2931 W, 1 cubic foot per hour = 0.0283 m³/h, 1 degree = 0.01745 rad.

Note: Table entries have been rounded to three significant digits.

TABLE G2413.4(10) ~~402.4(26)~~
SCHEDULE 40 METALLIC PIPE

Gas	Undiluted Propane
Inlet Pressure	10.0 psi
Pressure Drop	3.0 psi

INTENDED USE		Pipe sizing between first stage (high-pressure regulator) and second stage (low-pressure regulator).							
PIPE SIZE (inches)									
Nominal	1/2	3/4	1	1 1/4	1 1/2	2	2 1/2	3	4
Actual ID	0.622	0.824	1.049	1.380	1.610	2.067	2.469	3.068	4.026
Length (ft)	Capacity in Thousands of Btu per Hour								
10	5,890	12,300	23,200	47,600	71,300	137,000	219,000	387,000	789,000
20	4,050	8,460	15,900	32,700	49,000	94,400	150,000	266,000	543,000
30	3,250	6,790	12,800	26,300	39,400	75,800	121,000	214,000	436,000
40	2,780	5,810	11,000	22,500	33,700	64,900	103,000	183,000	373,000
50	2,460	5,150	9,710	19,900	29,900	57,500	91,600	162,000	330,000
60	2,230	4,670	8,790	18,100	27,100	52,100	83,000	147,000	299,000
70	2,050	4,300	8,090	16,600	24,900	47,900	76,400	135,000	275,000
80	1,910	4,000	7,530	15,500	23,200	44,600	71,100	126,000	256,000
90	1,790	3,750	7,060	14,500	21,700	41,800	66,700	118,000	240,000
100	1,690	3,540	6,670	13,700	20,500	39,500	63,000	111,000	227,000
125	1,500	3,140	5,910	12,100	18,200	35,000	55,800	98,700	201,000
150	1,360	2,840	5,360	11,000	16,500	31,700	50,600	89,400	182,000
175	1,250	2,620	4,930	10,100	15,200	29,200	46,500	82,300	167,800
200	1,160	2,430	4,580	9,410	14,100	27,200	43,300	76,500	156,100
250	1,030	2,160	4,060	8,340	12,500	24,100	38,400	67,800	138,400
300	935	1,950	3,680	7,560	11,300	21,800	34,800	61,500	125,400
350	860	1,800	3,390	6,950	10,400	20,100	32,000	56,500	115,300
400	800	1,670	3,150	6,470	9,690	18,700	29,800	52,600	107,300
450	751	1,570	2,960	6,070	9,090	17,500	27,900	49,400	100,700
500	709	1,480	2,790	5,730	8,590	16,500	26,400	46,600	95,100
550	673	1,410	2,650	5,450	8,160	15,700	25,000	44,300	90,300
600	642	1,340	2,530	5,200	7,780	15,000	23,900	42,200	86,200
650	615	1,290	2,420	4,980	7,450	14,400	22,900	40,500	82,500
700	591	1,240	2,330	4,780	7,160	13,800	22,000	38,900	79,300
750	569	1,190	2,240	4,600	6,900	13,300	21,200	37,400	76,400
800	550	1,150	2,170	4,450	6,660	12,800	20,500	36,200	73,700
850	532	1,110	2,100	4,300	6,450	12,400	19,800	35,000	71,400
900	516	1,080	2,030	4,170	6,250	12,000	19,200	33,900	69,200
950	501	1,050	1,970	4,050	6,070	11,700	18,600	32,900	67,200
1,000	487	1,020	1,920	3,940	5,900	11,400	18,100	32,000	65,400
1,100	463	968	1,820	3,740	5,610	10,800	17,200	30,400	62,100
1,200	442	923	1,740	3,570	5,350	10,300	16,400	29,000	59,200
1,300	423	884	1,670	3,420	5,120	9,870	15,700	27,800	56,700
1,400	406	849	1,600	3,280	4,920	9,480	15,100	26,700	54,500
1,500	391	818	1,540	3,160	4,740	9,130	14,600	25,700	52,500
1,600	378	790	1,490	3,060	4,580	8,820	14,100	24,800	50,700
1,700	366	765	1,440	2,960	4,430	8,530	13,600	24,000	49,000
1,800	355	741	1,400	2,870	4,300	8,270	13,200	23,300	47,600
1,900	344	720	1,360	2,780	4,170	8,040	12,800	22,600	46,200
2,000	335	700	1,320	2,710	4,060	7,820	12,500	22,000	44,900

For SI: 1 inch = 25.4 mm, 1 foot = 304.8 mm, 1 pound per square inch = 6.895 kPa, 1-inch water column = 0.2488 kPa, 1 British thermal unit per hour = 0.2931 W, 1 cubic foot per hour = 0.0283 m³/h, 1 degree = 0.01745 rad.

Note: Table entries have been rounded to three significant digits.

TABLE G2413.4(11) ~~1402.4(27)~~
SCHEDULE 40 METALLIC PIPE

Gas	Undiluted Propane
Inlet Pressure	2.0 psi
Pressure Drop	1.0 psi

INTENDED USE		Pipe sizing between 2 psig service and line pressure regulator.							
		PIPE SIZE (inches)							
Nominal	1/2	3/4	1	1 1/4	1 1/2	2	2 1/2	3	4
Actual ID	0.622	0.824	1.049	1.380	1.610	2.067	2.469	3.068	4.026
Length (ft)	Capacity in Thousands of Btu per Hour								
10	2,680	5,590	10,500	21,600	32,400	62,400	99,500	176,000	359,000
20	1,840	3,850	7,240	14,900	22,300	42,900	68,400	121,000	247,000
30	1,480	3,090	5,820	11,900	17,900	34,500	54,900	97,100	198,000
40	1,260	2,640	4,980	10,200	15,300	29,500	47,000	83,100	170,000
50	1,120	2,340	4,410	9,060	13,600	26,100	41,700	73,700	150,000
60	1,010	2,120	4,000	8,210	12,300	23,700	37,700	66,700	136,000
70	934	1,950	3,680	7,550	11,300	21,800	34,700	61,400	125,000
80	869	1,820	3,420	7,020	10,500	20,300	32,300	57,100	116,000
90	815	1,700	3,210	6,590	9,880	19,000	30,300	53,600	109,000
100	770	1,610	3,030	6,230	9,330	18,000	28,600	50,600	103,000
125	682	1,430	2,690	5,520	8,270	15,900	25,400	44,900	91,500
150	618	1,290	2,440	5,000	7,490	14,400	23,000	40,700	82,900
175	569	1,190	2,240	4,600	6,890	13,300	21,200	37,400	76,300
200	529	1,110	2,080	4,280	6,410	12,300	19,700	34,800	71,000
250	469	981	1,850	3,790	5,680	10,900	17,400	30,800	62,900
300	425	889	1,670	3,440	5,150	9,920	15,800	27,900	57,000
350	391	817	1,540	3,160	4,740	9,120	14,500	25,700	52,400
400	364	760	1,430	2,940	4,410	8,490	13,500	23,900	48,800
450	341	714	1,340	2,760	4,130	7,960	12,700	22,400	45,800
500	322	674	1,270	2,610	3,910	7,520	12,000	21,200	43,200
550	306	640	1,210	2,480	3,710	7,140	11,400	20,100	41,100
600	292	611	1,150	2,360	3,540	6,820	10,900	19,200	39,200
650	280	585	1,100	2,260	3,390	6,530	10,400	18,400	37,500
700	269	562	1,060	2,170	3,260	6,270	9,990	17,700	36,000
750	259	541	1,020	2,090	3,140	6,040	9,630	17,000	34,700
800	250	523	985	2,020	3,030	5,830	9,300	16,400	33,500
850	242	506	953	1,960	2,930	5,640	9,000	15,900	32,400
900	235	490	924	1,900	2,840	5,470	8,720	15,400	31,500
950	228	476	897	1,840	2,760	5,310	8,470	15,000	30,500
1,000	222	463	873	1,790	2,680	5,170	8,240	14,600	29,700
1,100	210	440	829	1,700	2,550	4,910	7,830	13,800	28,200
1,200	201	420	791	1,620	2,430	4,680	7,470	13,200	26,900
1,300	192	402	757	1,550	2,330	4,490	7,150	12,600	25,800
1,400	185	386	727	1,490	2,240	4,310	6,870	12,100	24,800
1,500	178	372	701	1,440	2,160	4,150	6,620	11,700	23,900
1,600	172	359	677	1,390	2,080	4,010	6,390	11,300	23,000
1,700	166	348	655	1,340	2,010	3,880	6,180	10,900	22,300
1,800	161	337	635	1,300	1,950	3,760	6,000	10,600	21,600
1,900	157	327	617	1,270	1,900	3,650	5,820	10,300	21,000
2,000	152	318	600	1,230	1,840	3,550	5,660	10,000	20,400

For SI: 1 inch = 25.4 mm, 1 foot = 304.8 mm, 1 pound per square inch = 6.895 kPa, 1-inch water column = 0.2488 kPa, 1 British thermal unit per hour = 0.2931 W, 1 cubic foot per hour = 0.0283 m³/h, 1 degree = 0.01745 rad.

Note: Table entries have been rounded to three significant digits.

TABLE G2413.4(12) ~~402.4(28)~~
SCHEDULE 40 METALLIC PIPE

	Gas	Undiluted Propane
	Inlet Pressure	11.0 in. w.c.
	Pressure Drop	0.5 in. w.c.

INTENDED USE		Pipe sizing between single- or second-stage (low pressure) regulator and appliance.							
		PIPE SIZE (inches)							
Nominal	1/2	3/4	1	1 1/4	1 1/2	2	2 1/2	3	4
Actual ID	0.622	0.824	1.049	1.380	1.610	2.067	2.469	3.068	4.026
Length (ft)	Capacity in Thousands of Btu per Hour								
10	291	608	1,150	2,350	3,520	6,790	10,800	19,100	39,000
20	200	418	787	1,620	2,420	4,660	7,430	13,100	26,800
30	160	336	632	1,300	1,940	3,750	5,970	10,600	21,500
40	137	287	541	1,110	1,660	3,210	5,110	9,030	18,400
50	122	255	480	985	1,480	2,840	4,530	8,000	16,300
60	110	231	434	892	1,340	2,570	4,100	7,250	14,800
80	101	212	400	821	1,230	2,370	3,770	6,670	13,600
100	94	197	372	763	1,140	2,200	3,510	6,210	12,700
125	89	185	349	716	1,070	2,070	3,290	5,820	11,900
150	84	175	330	677	1,010	1,950	3,110	5,500	11,200
175	74	155	292	600	899	1,730	2,760	4,880	9,950
200	67	140	265	543	814	1,570	2,500	4,420	9,010
250	62	129	243	500	749	1,440	2,300	4,060	8,290
300	58	120	227	465	697	1,340	2,140	3,780	7,710
350	51	107	201	412	618	1,190	1,900	3,350	6,840
400	46	97	182	373	560	1,080	1,720	3,040	6,190
450	42	89	167	344	515	991	1,580	2,790	5,700
500	40	83	156	320	479	922	1,470	2,600	5,300
550	37	78	146	300	449	865	1,380	2,440	4,970
600	35	73	138	283	424	817	1,300	2,300	4,700
650	33	70	131	269	403	776	1,240	2,190	4,460
700	32	66	125	257	385	741	1,180	2,090	4,260
750	30	64	120	246	368	709	1,130	2,000	4,080
800	29	61	115	236	354	681	1,090	1,920	3,920
850	28	59	111	227	341	656	1,050	1,850	3,770
900	27	57	107	220	329	634	1,010	1,790	3,640
950	26	55	104	213	319	613	978	1,730	3,530
1,000	25	53	100	206	309	595	948	1,680	3,420
1,100	25	52	97	200	300	578	921	1,630	3,320
1,200	24	50	95	195	292	562	895	1,580	3,230
1,300	23	48	90	185	277	534	850	1,500	3,070
1,400	22	46	86	176	264	509	811	1,430	2,930
1,500	21	44	82	169	253	487	777	1,370	2,800
1,200	24	50	95	195	292	562	895	1,580	3,230
1,300	23	48	90	185	277	534	850	1,500	3,070
1,400	22	46	86	176	264	509	811	1,430	2,930
1,500	21	44	82	169	253	487	777	1,370	2,800
1,600	20	42	79	162	243	468	746	1,320	2,690
1,700	19	40	76	156	234	451	719	1,270	2,590
1,800	19	39	74	151	226	436	694	1,230	2,500
1,900	18	38	71	146	219	422	672	1,190	2,420
2,000	18	37	69	142	212	409	652	1,150	2,350

For SI: 1 inch = 25.4 mm, 1 foot = 304.8 mm, 1 pound per square inch = 6.895 kPa, 1-inch water column = 0.2488 kPa, 1 British thermal unit per hour = 0.2931 W, 1 cubic foot per hour = 0.0283 m³/h, 1 degree = 0.01745 rad.

Note: Table entries have been rounded to three significant digits.

TABLE G2413.4(13) ~~402.4(29)~~
SEMIRIGID COPPER TUBING

Gas	Undiluted Propane
Inlet Pressure	10.0 psi
Pressure Drop	1.0 psi

INTENDED USE		Sizing between first stage (high-pressure regulator) and second stage (low-pressure regulator).								
		TUBE SIZE (inches)								
Nominal	K & L	1/4	3/8	1/2	5/8	3/4	1	1 1/4	1 1/2	2
	ACR	3/8	1/2	5/8	3/4	7/8	1 1/8	1 3/8	—	—
Outside		0.375	0.500	0.625	0.750	0.875	1.125	1.375	1.625	2.125
Inside		0.305	0.402	0.527	0.652	0.745	0.995	1.245	1.481	1.959
Length (ft)		Capacity in Thousands of Btu per Hour								
10	513	1,060	2,150	3,760	5,330	11,400	20,500	32,300	67,400	
20	352	727	1,480	2,580	3,670	7,830	14,100	22,200	46,300	
30	283	584	1,190	2,080	2,940	6,290	11,300	17,900	37,200	
40	242	500	1,020	1,780	2,520	5,380	9,690	15,300	31,800	
50	215	443	901	1,570	2,230	4,770	8,590	13,500	28,200	
60	194	401	816	1,430	2,020	4,320	7,780	12,300	25,600	
70	179	369	751	1,310	1,860	3,980	7,160	11,300	23,500	
80	166	343	699	1,220	1,730	3,700	6,660	10,500	21,900	
90	156	322	655	1,150	1,630	3,470	6,250	9,850	20,500	
100	147	304	619	1,080	1,540	3,280	5,900	9,310	19,400	
125	131	270	549	959	1,360	2,910	5,230	8,250	17,200	
150	118	244	497	869	1,230	2,630	4,740	7,470	15,600	
175	109	225	457	799	1,130	2,420	4,360	6,880	14,300	
200	101	209	426	744	1,060	2,250	4,060	6,400	13,300	
250	90	185	377	659	935	2,000	3,600	5,670	11,800	
300	81	168	342	597	847	1,810	3,260	5,140	10,700	
350	75	155	314	549	779	1,660	3,000	4,730	9,840	
400	70	144	292	511	725	1,550	2,790	4,400	9,160	
450	65	135	274	480	680	1,450	2,620	4,130	8,590	
500	62	127	259	453	643	1,370	2,470	3,900	8,120	
550	59	121	246	430	610	1,300	2,350	3,700	7,710	
600	56	115	235	410	582	1,240	2,240	3,530	7,350	
650	54	111	225	393	558	1,190	2,140	3,380	7,040	
700	51	106	216	378	536	1,140	2,060	3,250	6,770	
750	50	102	208	364	516	1,100	1,980	3,130	6,520	
800	48	99	201	351	498	1,060	1,920	3,020	6,290	
850	46	96	195	340	482	1,030	1,850	2,920	6,090	
900	45	93	189	330	468	1,000	1,800	2,840	5,910	
950	44	90	183	320	454	970	1,750	2,750	5,730	
1,000	42	88	178	311	442	944	1,700	2,680	5,580	
1,100	40	83	169	296	420	896	1,610	2,540	5,300	
1,200	38	79	161	282	400	855	1,540	2,430	5,050	
1,300	37	76	155	270	383	819	1,470	2,320	4,840	
1,400	35	73	148	260	368	787	1,420	2,230	4,650	
1,500	34	70	143	250	355	758	1,360	2,150	4,480	
1,600	33	68	138	241	343	732	1,320	2,080	4,330	
1,700	32	66	134	234	331	708	1,270	2,010	4,190	
1,800	31	64	130	227	321	687	1,240	1,950	4,060	
1,900	30	62	126	220	312	667	1,200	1,890	3,940	
2,000	29	60	122	214	304	648	1,170	1,840	3,830	

For SI: 1 inch = 25.4 mm, 1 foot = 304.8 mm, 1 pound per square inch = 6.895 kPa, 1-inch water column = 0.2488 kPa, 1 British thermal unit per hour = 0.2931 W, 1 cubic foot per hour = 0.0283 m³/h, 1 degree = 0.01745 rad.

- Notes:**
1. Table capacities are based on Type K copper tubing inside diameter (shown), which has the smallest inside diameter of the copper tubing products.
 2. Table entries have been rounded to three significant digits.

TABLE G2413.4(14) ~~402.4(30)~~
SEMIRIGID COPPER TUBING

	Gas	Undiluted Propane
	Inlet Pressure	11.0 in. w.c.
	Pressure Drop	0.5 in. w.c.

INTENDED USE		Sizing between single- or second-stage (low-pressure regulator) and appliance.								
TUBE SIZE (inches)										
Nominal	K & L	1/4	3/8	1/2	5/8	3/4	1	1 1/4	1 1/2	2
	ACR	3/8	1/2	5/8	3/4	7/8	1 1/8	1 3/8	—	—
Outside		0.375	0.500	0.625	0.750	0.875	1.125	1.375	1.625	2.125
Inside		0.305	0.402	0.527	0.652	0.745	0.995	1.245	1.481	1.959
Length (ft)		Capacity in Thousands of Btu per Hour								
10	45	93	188	329	467	997	1,800	2,830	5,890	
20	31	64	129	226	321	685	1,230	1,950	4,050	
30	25	51	104	182	258	550	991	1,560	3,250	
40	21	44	89	155	220	471	848	1,340	2,780	
50	19	39	79	138	195	417	752	1,180	2,470	
60	17	35	71	125	177	378	681	1,070	2,240	
70	16	32	66	115	163	348	626	988	2,060	
80	15	30	61	107	152	324	583	919	1,910	
90	14	28	57	100	142	304	547	862	1,800	
100	13	27	54	95	134	287	517	814	1,700	
125	11	24	48	84	119	254	458	722	1,500	
150	10	21	44	76	108	230	415	654	1,360	
175	NA	20	40	70	99	212	382	602	1,250	
200	NA	18	37	65	92	197	355	560	1,170	
250	NA	16	33	58	82	175	315	496	1,030	
300	NA	15	30	52	74	158	285	449	936	
350	NA	14	28	48	68	146	262	414	861	
400	NA	13	26	45	63	136	244	385	801	
450	NA	12	24	42	60	127	229	361	752	
500	NA	11	23	40	56	120	216	341	710	
550	NA	11	22	38	53	114	205	324	674	
600	NA	10	21	36	51	109	196	309	643	
650	NA	NA	20	34	49	104	188	296	616	
700	NA	NA	19	33	47	100	180	284	592	
750	NA	NA	18	32	45	96	174	274	570	
800	NA	NA	18	31	44	93	168	264	551	
850	NA	NA	17	30	42	90	162	256	533	
900	NA	NA	17	29	41	87	157	248	517	
950	NA	NA	16	28	40	85	153	241	502	
1,000	NA	NA	16	27	39	83	149	234	488	
1,100	NA	NA	15	26	37	78	141	223	464	
1,200	NA	NA	14	25	35	75	135	212	442	
1,300	NA	NA	14	24	34	72	129	203	423	
1,400	NA	NA	13	23	32	69	124	195	407	
1,500	NA	NA	13	22	31	66	119	188	392	
1,600	NA	NA	12	21	30	64	115	182	378	
1,700	NA	NA	12	20	29	62	112	176	366	
1,800	NA	NA	11	20	28	60	108	170	355	
1,900	NA	NA	11	19	27	58	105	166	345	
2,000	NA	NA	11	19	27	57	102	161	335	

For SI: 1 inch = 25.4 mm, 1 foot = 304.8 mm, 1 pound per square inch = 6.895 kPa, 1-inch water column = 0.2488 kPa, 1 British thermal unit per hour = 0.2931 W, 1 cubic foot per hour = 0.0283 m³/h, 1 degree = 0.01745 rad.

Notes:

1. Table capacities are based on Type K copper tubing inside diameter (shown), which has the smallest inside diameter of the copper tubing products.
2. NA means a flow of less than 10,000 Btu/hr.
3. Table entries have been rounded to three significant digits.

TABLE G2413.4(15) ~~402.4(31)~~
SEMIRIGID COPPER TUBING

Gas	Undiluted Propane
Inlet Pressure	2.0 psi
Pressure Drop	1.0 psi

INTENDED USE		Tube sizing between 2 psig service and line pressure regulator.								
		TUBE SIZE (inches)								
Nominal	K & L	1/4	3/8	1/2	5/8	3/4	1	1 1/4	1 1/2	2
	ACR	3/8	1/2	5/8	3/4	7/8	1 1/8	1 3/8	—	—
Outside		0.375	0.500	0.625	0.750	0.875	1.125	1.375	1.625	2.125
Inside		0.305	0.402	0.527	0.652	0.745	0.995	1.245	1.481	1.959
Length (ft)		Capacity in Thousands of Btu per Hour								
10		413	852	1,730	3,030	4,300	9,170	16,500	26,000	54,200
20		284	585	1,190	2,080	2,950	6,310	11,400	17,900	37,300
30		228	470	956	1,670	2,370	5,060	9,120	14,400	29,900
40		195	402	818	1,430	2,030	4,330	7,800	12,300	25,600
50		173	356	725	1,270	1,800	3,840	6,920	10,900	22,700
60		157	323	657	1,150	1,630	3,480	6,270	9,880	20,600
70		144	297	605	1,060	1,500	3,200	5,760	9,090	18,900
80		134	276	562	983	1,390	2,980	5,360	8,450	17,600
90		126	259	528	922	1,310	2,790	5,030	7,930	16,500
100		119	245	498	871	1,240	2,640	4,750	7,490	15,600
125		105	217	442	772	1,100	2,340	4,210	6,640	13,800
150		95	197	400	700	992	2,120	3,820	6,020	12,500
175		88	181	368	644	913	1,950	3,510	5,540	11,500
200		82	168	343	599	849	1,810	3,270	5,150	10,700
250		72	149	304	531	753	1,610	2,900	4,560	9,510
300		66	135	275	481	682	1,460	2,620	4,140	8,610
350		60	124	253	442	628	1,340	2,410	3,800	7,920
400		56	116	235	411	584	1,250	2,250	3,540	7,370
450		53	109	221	386	548	1,170	2,110	3,320	6,920
500		50	103	209	365	517	1,110	1,990	3,140	6,530
550		47	97	198	346	491	1,050	1,890	2,980	6,210
600		45	93	189	330	469	1,000	1,800	2,840	5,920
650		43	89	181	316	449	959	1,730	2,720	5,670
700		41	86	174	304	431	921	1,660	2,620	5,450
750		40	82	168	293	415	888	1,600	2,520	5,250
800		39	80	162	283	401	857	1,540	2,430	5,070
850		37	77	157	274	388	829	1,490	2,350	4,900
900		36	75	152	265	376	804	1,450	2,280	4,750
950		35	72	147	258	366	781	1,410	2,220	4,620
1,000		34	71	143	251	356	760	1,370	2,160	4,490
1,100		32	67	136	238	338	721	1,300	2,050	4,270
1,200		31	64	130	227	322	688	1,240	1,950	4,070
1,300		30	61	124	217	309	659	1,190	1,870	3,900
1,400		28	59	120	209	296	633	1,140	1,800	3,740
1,500		27	57	115	201	286	610	1,100	1,730	3,610
1,600		26	55	111	194	276	589	1,060	1,670	3,480
1,700		26	53	108	188	267	570	1,030	1,620	3,370
1,800		25	51	104	182	259	553	1,000	1,570	3,270
1,900		24	50	101	177	251	537	966	1,520	3,170
2,000		23	48	99	172	244	522	940	1,480	3,090

For SI: 1 inch = 25.4 mm, 1 foot = 304.8 mm, 1 pound per square inch = 6.895 kPa, 1-inch water column = 0.2488 kPa, 1 British thermal unit per hour = 0.2931 W, 1 cubic foot per hour = 0.0283 m³/h, 1 degree = 0.01745 rad.

Notes:

1. Table capacities are based on Type K copper tubing inside diameter (shown), which has the smallest inside diameter of the copper tubing products.
2. Table entries have been rounded to three significant digits.

TABLE G2413.4(16) ~~402.4(32)~~
CORRUGATED STAINLESS STEEL TUBING (CSST)

Gas	Undiluted Propane
Inlet Pressure	11.0 in. w.c.
Pressure Drop	0.5 in. w.c.

INTENDED USE: SIZING BETWEEN SINGLE OR SECOND STAGE (Low Pressure) REGULATOR AND THE APPLIANCE SHUTOFF VALVE.														
TUBE SIZE (EHD)														
Flow Designation	13	15	18	19	23	25	30	31	37	39	46	48	60	62
Length (ft)	Capacity in Thousands of Btu per Hour													
5	72	99	181	211	355	426	744	863	1,420	1,638	2,830	3,270	5,780	6,550
10	50	69	129	150	254	303	521	605	971	1,179	1,990	2,320	4,110	4,640
15	39	55	104	121	208	248	422	490	775	972	1,620	1,900	3,370	3,790
20	34	49	91	106	183	216	365	425	661	847	1,400	1,650	2,930	3,290
25	30	42	82	94	164	192	325	379	583	762	1,250	1,480	2,630	2,940
30	28	39	74	87	151	177	297	344	528	698	1,140	1,350	2,400	2,680
40	23	33	64	74	131	153	256	297	449	610	988	1,170	2,090	2,330
50	20	30	58	66	118	137	227	265	397	548	884	1,050	1,870	2,080
60	19	26	53	60	107	126	207	241	359	502	805	961	1,710	1,900
70	17	25	49	57	99	117	191	222	330	466	745	890	1,590	1,760
80	15	23	45	52	94	109	178	208	307	438	696	833	1,490	1,650
90	15	22	44	50	90	102	169	197	286	414	656	787	1,400	1,550
100	14	20	41	47	85	98	159	186	270	393	621	746	1,330	1,480
150	11	15	31	36	66	75	123	143	217	324	506	611	1,090	1,210
200	9	14	28	33	60	69	112	129	183	283	438	531	948	1,050
250	8	12	25	30	53	61	99	117	163	254	390	476	850	934
300	8	11	23	26	50	57	90	107	147	234	357	434	777	854

For SI: 1 inch = 25.4 mm, 1 foot = 304.8 mm, 1 pound per square inch = 6.895 kPa, 1-inch water column = 0.2488 kPa, 1 British thermal unit per hour = 0.2931 W, 1 cubic foot per hour = 0.0283 m³/h, 1 degree = 0.01745 rad.

- Notes:**
1. Table includes losses for four 90-degree bends and two end fittings. Tubing runs with larger numbers of bends or fittings shall be increased by an equivalent length of tubing to the following equation: $L = 1.3n$ where L is additional length (feet) of tubing and n is the number of additional fittings or bends.
 2. EHD—Equivalent Hydraulic Diameter, which is a measure of the relative hydraulic efficiency between different tubing sizes. The greater the value of EHD, the greater the gas capacity of the tubing.
 3. Table entries have been rounded to three significant digits.

TABLE G2413.4(17) ~~402.4(33)~~
 CORRUGATED STAINLESS STEEL TUBING (CSST)

Gas	Undiluted Propane
Inlet Pressure	2.0 psi
Pressure Drop	1.0 psi

INTENDED USE: SIZING BETWEEN 2 PSI SERVICE AND THE LINE PRESSURE REGULATOR.														
TUBE SIZE (EHD)														
Flow Designation	13	15	18	19	23	25	30	31	37	39	46	48	60	62
Length (ft)	Capacity in Thousands of Btu per Hour													
10	426	558	927	1,110	1,740	2,170	4,100	4,720	7,130	7,958	15,200	16,800	29,400	34,200
25	262	347	591	701	1,120	1,380	2,560	2,950	4,560	5,147	9,550	10,700	18,800	21,700
30	238	316	540	640	1,030	1,270	2,330	2,690	4,180	4,719	8,710	9,790	17,200	19,800
40	203	271	469	554	896	1,100	2,010	2,320	3,630	4,116	7,530	8,500	14,900	17,200
50	181	243	420	496	806	986	1,790	2,070	3,260	3,702	6,730	7,610	13,400	15,400
75	147	196	344	406	663	809	1,460	1,690	2,680	3,053	5,480	6,230	11,000	12,600
80	140	189	333	393	643	768	1,410	1,630	2,590	2,961	5,300	6,040	10,600	12,200
100	124	169	298	350	578	703	1,260	1,450	2,330	2,662	4,740	5,410	9,530	10,900
150	101	137	245	287	477	575	1,020	1,180	1,910	2,195	3,860	4,430	7,810	8,890
200	86	118	213	248	415	501	880	1,020	1,660	1,915	3,340	3,840	6,780	7,710
250	77	105	191	222	373	448	785	910	1,490	1,722	2,980	3,440	6,080	6,900
300	69	96	173	203	343	411	716	829	1,360	1,578	2,720	3,150	5,560	6,300
400	60	82	151	175	298	355	616	716	1,160	1,376	2,350	2,730	4,830	5,460
500	53	72	135	158	268	319	550	638	1,030	1,237	2,100	2,450	4,330	4,880

For SI: 1 inch = 25.4 mm, 1 foot = 304.8 mm, 1 pound per square inch = 6.895 kPa, 1-inch water column = 0.2488 kPa, 1 British thermal unit per hour = 0.2931 W, 1 cubic foot per hour = 0.0283 m³/h, 1 degree = 0.01745 rad.

- Notes:**
1. Table does not include effect of pressure drop across the line regulator. Where regulator loss exceeds 1/2 psi (based on 13 in. w.c. outlet pressure), DO NOT USE THIS TABLE. Consult with the regulator manufacturer for pressure drops and capacity factors. Pressure drops across a regulator can vary with flow rate.
 2. CAUTION: Capacities shown in the table might exceed maximum capacity for a selected regulator. Consult with the regulator or tubing manufacturer for guidance.
 3. Table includes losses for four 90-degree bends and two end fittings. Tubing runs with larger numbers of bends or fittings shall be increased by an equivalent length of tubing to the following equation: $L = 1.3n$ where L is additional length (feet) of tubing and n is the number of additional fittings or bends.
 4. EHD—Equivalent Hydraulic Diameter, which is a measure of the relative hydraulic efficiency between different tubing sizes. The greater the value of EHD, the greater the gas capacity of the tubing.
 5. Table entries have been rounded to three significant digits.

**TABLE G2413.4(18) [402.4(34)]
CORRUGATED STAINLESS STEEL TUBING (CSST)**

Gas	Undiluted Propane
Inlet Pressure	5.0 psi
Pressure Drop	3.5 psi

TUBE SIZE (EHD)														
Flow Designation	13	15	18	19	23	25	30	31	37	39	46	48	60	62
Length (ft)	Capacity in Thousands of Btu per Hour													
10	826	1,070	1,710	2,060	3,150	4,000	7,830	8,950	13,100	14,441	28,600	31,200	54,400	63,800
25	509	664	1,090	1,310	2,040	2,550	4,860	5,600	8,400	9,339	18,000	19,900	34,700	40,400
30	461	603	999	1,190	1,870	2,340	4,430	5,100	7,680	8,564	16,400	18,200	31,700	36,900
40	396	520	867	1,030	1,630	2,030	3,820	4,400	6,680	7,469	14,200	15,800	27,600	32,000
50	352	463	777	926	1,460	1,820	3,410	3,930	5,990	6,717	12,700	14,100	24,700	28,600
75	284	376	637	757	1,210	1,490	2,770	3,190	4,920	5,539	10,300	11,600	20,300	23,400
80	275	363	618	731	1,170	1,450	2,680	3,090	4,770	5,372	9,990	11,200	19,600	22,700
100	243	324	553	656	1,050	1,300	2,390	2,760	4,280	4,830	8,930	10,000	17,600	20,300
150	196	262	453	535	866	1,060	1,940	2,240	3,510	3,983	7,270	8,210	14,400	16,600
200	169	226	393	464	755	923	1,680	1,930	3,050	3,474	6,290	7,130	12,500	14,400
250	150	202	352	415	679	828	1,490	1,730	2,740	3,124	5,620	6,390	11,200	12,900
300	136	183	322	379	622	757	1,360	1,570	2,510	2,865	5,120	5,840	10,300	11,700
400	117	158	279	328	542	657	1,170	1,360	2,180	2,498	4,430	5,070	8,920	10,200
500	104	140	251	294	488	589	1,050	1,210	1,950	2,247	3,960	4,540	8,000	9,110

For SI: 1 inch = 25.4 mm, 1 foot = 304.8 mm, 1 pound per square inch = 6.895 kPa, 1-inch water column = 0.2488 kPa, 1 British thermal unit per hour = 0.2931 W, 1 cubic foot per hour = 0.0283 m³/h, 1 degree = 0.01745 rad.

- Notes:**
1. Table does not include effect of pressure drop across line regulator. Where regulator loss exceeds 1 psi, DO NOT USE THIS TABLE. Consult with the regulator manufacturer for pressure drops and capacity factors. Pressure drop across regulator can vary with the flow rate.
 2. CAUTION: Capacities shown in the table might exceed maximum capacity of selected regulator. Consult with the tubing manufacturer for guidance.
 3. Table includes losses for four 90-degree bends and two end fittings. Tubing runs with larger numbers of bends or fittings shall be increased by an equivalent length of tubing to the following equation: $L = 1.3n$ where L is additional length (feet) of tubing and n is the number of additional fittings or bends.
 4. EHD—Equivalent Hydraulic Diameter, which is a measure of the relative hydraulic efficiency between different tubing sizes. The greater the value of EHD, the greater the gas capacity of the tubing.
 5. Table entries have been rounded to three significant digits.

TABLE G2413.4(19) ~~402.4(35)~~
POLYETHYLENE PLASTIC PIPE

Gas	Undiluted Propane
Inlet Pressure	11.0 in. w.c.
Pressure Drop	0.5 in. w.c.

INTENDED USE	PE pipe sizing between integral 2-stage regulator at tank or second stage (low-pressure regulator) and building.					
PIPE SIZE (inches)						
Nominal OD	1/2	3/4	1	1 1/4	1 1/2	2
Designation	SDR 9	SDR 11	SDR 11	SDR 10	SDR 11	SDR 11
Actual ID	0.660	0.860	1.077	1.328	1.554	1.943
Length (ft)	Capacity in Thousands of Btu per Hour					
10	340	680	1,230	2,130	3,210	5,770
20	233	468	844	1,460	2,210	3,970
30	187	375	677	1,170	1,770	3,180
40	160	321	580	1,000	1,520	2,730
50	142	285	514	890	1,340	2,420
60	129	258	466	807	1,220	2,190
70	119	237	428	742	1,120	2,010
80	110	221	398	690	1,040	1,870
90	103	207	374	648	978	1,760
100	98	196	353	612	924	1,660
125	87	173	313	542	819	1,470
150	78	157	284	491	742	1,330
175	72	145	261	452	683	1,230
200	67	135	243	420	635	1,140
250	60	119	215	373	563	1,010
300	54	108	195	338	510	916
350	50	99	179	311	469	843
400	46	92	167	289	436	784
450	43	87	157	271	409	736
500	41	82	148	256	387	695

For SI: 1 inch = 25.4 mm, 1 foot = 304.8 mm, 1 pound per square inch = 6.895 kPa, 1-inch water column = 0.2488 kPa, 1 British thermal unit per hour = 0.2931 W, 1 cubic foot per hour = 0.0283 m³/h, 1 degree = 0.01745 rad.

Note: Table entries have been rounded to three significant digits.

TABLE G2413.4(20) ~~402.4(36)~~
POLYETHYLENE PLASTIC PIPE

Gas	Undiluted Propane
Inlet Pressure	2.0 psi
Pressure Drop	1.0 psi

INTENDED USE	PE pipe sizing between 2 psig service regulator and line pressure regulator.					
PIPE SIZE (inches)						
Nominal OD	1/2	3/4	1	1 1/4	1 1/2	2
Designation	SDR 9	SDR 11	SDR 11	SDR 10	SDR 11	SDR 11
Actual ID	0.660	0.860	1.077	1.328	1.554	1.943
Length (ft)	Capacity in Thousands of Btu per Hour					
10	3,130	6,260	11,300	19,600	29,500	53,100
20	2,150	4,300	7,760	13,400	20,300	36,500
30	1,730	3,450	6,230	10,800	16,300	29,300
40	1,480	2,960	5,330	9,240	14,000	25,100
50	1,310	2,620	4,730	8,190	12,400	22,200
60	1,190	2,370	4,280	7,420	11,200	20,100
70	1,090	2,180	3,940	6,830	10,300	18,500
80	1,010	2,030	3,670	6,350	9,590	17,200
90	952	1,910	3,440	5,960	9,000	16,200
100	899	1,800	3,250	5,630	8,500	15,300
125	797	1,600	2,880	4,990	7,530	13,500
150	722	1,450	2,610	4,520	6,830	12,300
175	664	1,330	2,400	4,160	6,280	11,300
200	618	1,240	2,230	3,870	5,840	10,500
250	548	1,100	1,980	3,430	5,180	9,300
300	496	994	1,790	3,110	4,690	8,430
350	457	914	1,650	2,860	4,320	7,760
400	425	851	1,530	2,660	4,020	7,220
450	399	798	1,440	2,500	3,770	6,770
500	377	754	1,360	2,360	3,560	6,390
550	358	716	1,290	2,240	3,380	6,070
600	341	683	1,230	2,140	3,220	5,790
650	327	654	1,180	2,040	3,090	5,550
700	314	628	1,130	1,960	2,970	5,330
750	302	605	1,090	1,890	2,860	5,140
800	292	585	1,050	1,830	2,760	4,960
850	283	566	1,020	1,770	2,670	4,800
900	274	549	990	1,710	2,590	4,650
950	266	533	961	1,670	2,520	4,520
1,000	259	518	935	1,620	2,450	4,400
1,100	246	492	888	1,540	2,320	4,170
1,200	234	470	847	1,470	2,220	3,980
1,300	225	450	811	1,410	2,120	3,810
1,400	216	432	779	1,350	2,040	3,660
1,500	208	416	751	1,300	1,960	3,530
1,600	201	402	725	1,260	1,900	3,410
1,700	194	389	702	1,220	1,840	3,300
1,800	188	377	680	1,180	1,780	3,200
1,900	183	366	661	1,140	1,730	3,110
2,000	178	356	643	1,110	1,680	3,020

For SI: 1 inch = 25.4 mm, 1 foot = 304.8 mm, 1 pound per square inch = 6.895 kPa, 1-inch water column = 0.2488 kPa, 1 British thermal unit per hour = 0.2931 W, 1 cubic foot per hour = 0.0283 m³/h, 1 degree = 0.01745 rad.

Note: Table entries have been rounded to three significant digits.

TABLE G2413.4(21) ~~402.4(37)~~
POLYETHYLENE PLASTIC TUBING

Gas	Undiluted Propane
Inlet Pressure	11.0 in. w.c.
Pressure Drop	0.5 in. w.c.

INTENDED USE: PE PIPE SIZING BETWEEN INTEGRAL 2-STAGE REGULATOR AT TANK OR SECOND STAGE (low-pressure regulator) AND BUILDING.		
Plastic Tubing Size (CTS) (inch)		
Nominal OD	1/2	1
Designation	SDR 7	SDR 11
Actual ID	0.445	0.927
Length (ft)	Capacity in Cubic Feet of Gas per Hour	
10	121	828
20	83	569
30	67	457
40	57	391
50	51	347
60	46	314
70	42	289
80	39	269
90	37	252
100	35	238
125	31	211
150	28	191
175	26	176
200	24	164
225	22	154
250	21	145
275	20	138
300	19	132
350	18	121
400	16	113
450	15	106
500	15	100

For SI: 1 inch = 25.4 mm, 1 foot = 304.8 mm, 1 pound per square inch = 6.895 kPa, 1-inch water column = 0.2488 kPa, 1 British thermal unit per hour = 0.2931 W, 1 cubic foot per hour = 0.0283 m³/h, 1 degree = 0.01745 rad.

Note: Table entries have been rounded to three significant digits.

SECTION G2415 ~~(404)~~
PIPING SYSTEM INSTALLATION

G2415.1 ~~(404.1)~~ Installation of materials. Materials used shall be installed in strict accordance with the standards under which the materials are accepted and approved. In the absence of such installation procedures, the manufacturer's instructions shall be followed. Where the requirements of referenced standards or manufacturer's instructions do not conform to minimum provisions of this code, the provisions of this code shall apply.

G2415.2 ~~(404.2)~~ CSST. CSST piping systems shall be installed in accordance with the terms of their approval, the conditions of listing, the manufacturer's instructions and this code.

G2415.3 ~~(404.3)~~ Prohibited locations. *Piping* shall not be installed in or through a ducted supply, return or exhaust, or a clothes chute, *chimney* or gas vent, dumbwaiter or elevator shaft. *Piping* installed downstream of the *point of delivery* shall not extend through any townhouse unit other than the unit served by such *piping*.

G2415.4 ~~(404.4)~~ Piping in solid partitions and walls. *Concealed piping* shall not be located in solid partitions and solid walls, unless installed in a chase or casing.

G2415.5 ~~(404.5)~~ Fittings in concealed locations. Fittings installed in concealed locations shall be limited to the following types:

1. Threaded elbows, tees, couplings, **plugs and caps**.
2. Brazed fittings.
3. Welded fittings.
4. Fittings *listed* to ANSI LC1/CSA 6.26 or ANSI LC4/ CSA 6.32.

G2415.6 ~~(404.6)~~ Underground penetrations prohibited. Gas *piping* shall not penetrate building foundation walls at any point below grade. Gas *piping* shall enter and exit a building at a point above grade and the annular space between the *pipe* and the wall shall be sealed.

G2415.7 ~~(404.7)~~ Protection against physical damage. Where *piping* will be concealed within light-frame construction assemblies, the *piping* shall be protected against penetration by fasteners in accordance with Sections G2415.7.1 through G2415.7.3.

Exception: Black steel *piping* and galvanized steel *piping* shall not be required to be protected.

G2415.7.1 ~~(404.7.1)~~ Piping through bored holes or notches. Where *piping* is installed through holes or notches in framing members and the *piping* is located less than 1 1/2 inches (38 mm) from the framing member face to which wall, ceiling or floor membranes will be attached, the pipe shall be protected by shield plates that cover the width of the pipe and the framing member and that extend not less than 4 inches (102 mm) to each side of the framing member. Where the framing member that the *piping* passes through is a bottom plate, bottom track, top plate or top track, the shield plates shall cover the framing

member and extend not less than 4 inches (102 mm) above the bottom framing member and not less than 4 inches (102 mm) below the top framing member.

G2415.7.2 ~~(404.7.2)~~ Piping installed in other locations. Where the *piping* is located within a framing member and is less than 1 1/2 inches (38 mm) from the framing member face to which wall, ceiling or floor membranes will be attached, the *piping* shall be protected by shield plates that cover the width and length of the *piping*. Where the *piping* is located outside of a framing member and is located less than 1 1/2 inches (38 mm) from the nearest edge of the face of the framing member to which the membrane will be attached, the *piping* shall be protected by shield plates that cover the width and length of the *piping*.

2415.7.3 ~~(404.7.3)~~ Shield plates. Shield plates shall be of steel material having a thickness of not less than 0.0575 inch (1.463 mm) (No. 16 gage).

G2415.8 ~~(404.8)~~ Piping in solid floors. *Piping* in solid floors shall be laid in channels in the floor and covered in a manner that will allow access to the *piping* with a minimum amount of damage to the building. Where such *piping* is subject to exposure to excessive moisture or corrosive substances, the *piping* shall be protected in an *approved* manner. As an alternative to installation in channels, the *piping* shall be installed in a conduit of Schedule 40 steel, wrought iron, PVC or ABS pipe in accordance with Section G2415.8.1 or G2415.8.2.

G2415.8.1 ~~(404.8.1)~~ Conduit with one end terminating outdoors. The conduit shall extend into an occupiable portion of the building and, at the point where the conduit terminates in the building, the space between the conduit and the *gas piping* shall be sealed to prevent the possible entrance of any gas leakage. The conduit shall extend not less than 2 inches (51 mm) beyond the point where the *pipe* emerges from the floor. If the end sealing is capable of withstanding the full pressure of the *gas pipe*, the conduit shall be designed for the same pressure as the *pipe*. Such conduit shall extend not less than 4 inches (102 mm) outside the building, shall be vented above grade to the outdoors and shall be installed so as to prevent the entrance of water and insects.

G2415.8.2 ~~(404.8.2)~~ Conduit with both ends terminating indoors. Where the conduit originates and terminates within the same building, the conduit shall originate and terminate in an accessible portion of the building and shall not be sealed. The conduit shall extend not less than 2 inches (51 mm) beyond the point where the pipe emerges from the floor.

G2415.9 ~~(404.9)~~ Above-ground piping outdoors. *Piping* installed outdoors shall be elevated not less than 3 1/2 inches (89 mm) above ground and where installed across roof surfaces, shall be elevated not less than 3 1/2 inches (89 mm) above the roof surface. *Piping* installed above ground, outdoors, and installed

across the surface of roofs shall be securely supported and located where it will be protected from physical damage. Where passing through an outside wall, the *piping* shall be protected against corrosion by coating or wrapping with an inert material. Where *piping* is encased in a protective pipe sleeve, the annular space between the *piping* and the sleeve shall be sealed.

G2415.10 (404.10) Isolation. Metallic *piping* and metallic *tubing* that conveys *fuel gas* from an LP-gas storage container shall be provided with an *approved* dielectric fitting to electrically isolate the underground portion of the pipe or tube from the above-ground portion that enters a building. Such dielectric fitting shall be installed above ground, outdoors.

G2415.11 (404.11) Protection against corrosion. Steel pipe or *tubing* exposed to corrosive action, such as soil condition or moisture, shall be protected in accordance with Sections G2415.11.1 through G2415.11.4.

G2415.11.1 (404.11.1) Galvanizing. Zinc coating shall not be deemed adequate protection for underground gas piping.

G2415.11.2 (404.11.2) Protection methods. Underground piping shall comply with one or more of the following:

1. The piping shall be made of corrosion-resistant material that is suitable for the environment in which it will be installed.
2. Pipe shall have a factory-applied, electrically insulating coating. Fittings and joints between sections of coated pipe shall be coated in accordance with the coating manufacturer's instructions.
3. The piping shall have a cathodic protection system installed and the system shall be monitored and maintained in accordance with an approved program.

G2415.11.3 (404.11.3) Dissimilar metals. Where dissimilar metals are joined underground, an insulating coupling or fitting shall be used.

G2415.11.4 (404.11.4) Protection of risers. Steel risers connected to plastic piping shall be cathodically protected by means of a welded anode, except where such risers are anodeless risers.

~~**G2415.11 Corrosion and covering protection.** Nonmetallic gas piping and coated and cathodically protected piping shall have a minimum of 18 inches (457 mm) of earth cover or other equivalent protection. Risers, including prefabricated risers inserted with plastic pipe, shall be metallic and shall be protected in an approved manner to a point at least 6 inches (163 mm) above grade. When a riser connects to plastic pipe underground, the horizontal metallic portion underground shall be at least 30 inches (762 mm) in length before connecting to the plastic service pipe. An approved transition fitting or adapter shall be used where the plastic joins the metallic riser. Ferrous metals in exposed exterior locations shall be protected from corrosion in a manner approved by the building official after consulting with the gas supplier.~~

~~Ferrous pipes installed underground shall not be placed in contact with other metallic objects such as pipes or wires. Zinc coatings (galvanizing) shall not be deemed adequate protection for piping below grade. Ferrous gas piping installed underground in exterior locations shall be protected from corrosion by one of the following:~~

- ~~1. Coated and cathodically protected pipe. All gas pipe protective coatings shall be approved types, be machine applied and conform to recognized standards. Field wrapping shall provide equivalent protection and is restricted to those short sections and fittings necessarily stripped for threading or welding. Underground coated and wrapped gas piping shall be cathodically protected with galvanic anodes or rectifiers and electrically isolated from the rest of the system by insulating unions 6 inches (163 mm) above grade.~~
- ~~2. Unwrapped (bare) pipe and special covering. Unwrapped ferrous gas piping being installed underground in exterior locations shall be protected from corrosion by being installed within a minimum 6 inch (163 mm) protective bed of sand around the gas piping, the pipe being centrally located within the sand backfill, and all such horizontal piping shall have a minimum of 18 inches (457 mm) of earth cover or other equivalent protection. Underground piping shall be electrically isolated from the rest of the system by insulating unions placed a minimum of 6 inches (163 mm) above grade.~~
- ~~3. Electrical isolation of fuel gas piping. Underground ferrous gas piping shall be electrically isolated from the rest of the gas system with listed or approved isolation fittings installed a minimum of 6 inches (163 mm) above grade.~~

G2415.12 (404.12) Minimum burial depth. Underground *piping systems* shall be installed a minimum depth of ~~12-18~~ inches (305 457 mm) below grade, except as provided for in Section G2415.12.1.

G2415.12.1 (404.12.1) Individual outdoor appliances. Individual lines to outdoor lights, grills and other *appliances* shall be installed not less than 8 inches (203 mm) below finished grade, provided that such installation is *approved* and is installed in locations not susceptible to physical damage.

G2415.13 (404.13) Trenches. The trench shall be graded so that the pipe has a firm, substantially continuous bearing on the bottom of the trench.

G2415.14 (404.14) Piping underground beneath buildings. *Piping* installed underground beneath buildings is prohibited except where the *piping* is encased in a conduit of wrought iron, plastic pipe, steel pipe, a piping or encasement system listed for installation beneath buildings, or other *approved* conduit material designed to withstand the superimposed loads. The conduit shall be protected from corrosion in accordance with Section G2415.11 and shall be installed in accordance with Section G2415.14.1 or G2415.14.2.

G2415.14.1 ~~(404.14.1)~~ **Conduit with one end terminating outdoors.** The conduit shall extend into an occupiable portion of the building and, at the point where the conduit terminates in the building, the space between the conduit and the *gas piping* shall be sealed to prevent the possible entrance of any gas leakage. The conduit shall extend not less than 2 inches (51 mm) beyond the point where the *pipe* emerges from the floor. Where the end sealing is capable of withstanding the full pressure of the gas pipe, the conduit shall be designed for the same pressure as the pipe. Such conduit shall extend not less than 4 inches (102 mm) outside the building, shall be vented above grade to the outdoors and shall be installed so as to prevent the entrance of water and insects.

G2415.14.2 ~~(404.14.2)~~ **Conduit with both ends terminating indoors.** Where the conduit originates and terminates within the same building, the conduit shall originate and terminate in an accessible portion of the building and shall not be sealed. The conduit shall extend not less than 2 inches (51 mm) beyond the point where the pipe emerges from the floor.

G2415.15 ~~(404.15)~~ **Outlet closures.** Gas *outlets* that do not connect to *appliances* shall be capped gastight.

Exception: *Listed* and *labeled* flush-mounted-type quick-disconnect devices and *listed* and *labeled gas convenience outlets* shall be installed in accordance with the manufacturer's instructions.

G2415.16 ~~(404.16)~~ **Location of outlets.** The unthreaded portion of *piping outlets* shall extend not less than 1 inch (25 mm) through finished ceilings and walls and where extending through floors or outdoor patios and slabs, shall be not less than 2 inches (51 mm) above them. The *outlet* fitting or *piping* shall be securely supported. *Outlets* shall not be placed behind doors. *Outlets* shall be located in the room or space where the *appliance* is installed.

Exception: *Listed* and *labeled* flush-mounted-type quick-disconnect devices and *listed* and *labeled gas convenience outlets* shall be installed in accordance with the manufacturer's instructions.

G2415.17 ~~(404.17)~~ **Plastic pipe.** The installation of plastic *pipe* shall comply with Sections G2415.17.1 through G2415.17.3.

G2415.17.1 ~~(404.17.1)~~ **Limitations.** Plastic pipe shall be installed outdoors underground only. Plastic pipe shall not be used within or under any building or building slab or be operated at pressures greater than 100 psig (689 kPa) for natural gas or 30 psig (207 kPa) for LP-gas.

Exceptions:

1. Plastic pipe shall be permitted to terminate above ground outside of buildings where installed in premanufactured *anodeless risers* or service head adapter risers that are installed in accordance with the manufacturer's instructions.

2. Plastic pipe shall be permitted to terminate with a wall head adapter within buildings where the plastic pipe is inserted in a *piping* material for *fuel gas* use in buildings.
3. Plastic pipe shall be permitted under outdoor patio, walkway and driveway slabs provided that the burial depth complies with Section G2415.12.

G2415.17.2 ~~(404.17.2)~~ **Connections.** Connections made outdoors and underground between metallic and plastic *piping* shall be made only with transition fittings conforming to ASTM D2513 Category I or ASTM F1973.

G2415.17.3 ~~(404.17.3)~~ **Tracer.** A yellow -insulated copper tracer wire or other *approved* conductor, or a product specifically designed for that purpose, shall be installed adjacent to underground nonmetallic piping. *Access* shall be provided to the tracer wire or the tracer wire shall terminate above ground at each end of the nonmetallic *piping*. The tracer wire size shall be not less than 18 AWG and the insulation type shall be suitable for direct burial.

G2415.18 ~~(404.18)~~ **Pipe debris removal.** The interior of *piping* shall be clear of debris. The use of a flammable or combustible gas to clean or remove debris from a *piping* system shall be prohibited.

G2415.19 ~~(404.19)~~ **Prohibited devices.** A device shall not be placed inside the *piping* or fittings that will reduce the cross-sectional area or otherwise obstruct the free flow of gas.

Exceptions:

1. Approved gas filters.
2. An approved fitting or device where the gas piping system has been sized to accommodate the pressure drop of the fitting or device.

G2415.20 ~~(404.20)~~ **Testing of piping.** Before any system of *piping* is put in service or concealed, it shall be tested to ensure that it is gastight. Testing, inspection and purging of *piping systems* shall comply with Section G2417.

SECTION G2416 ~~(405)~~

PIPING BENDS AND CHANGES IN DIRECTION

G2416.1 ~~(405.1)~~ **General.** Changes in direction of pipe shall be permitted to be made by the use of fittings, factory bends or field bends.

G2416.2 ~~(405.2)~~ **Metallic pipe.** Metallic pipe bends shall comply with the following:

1. Bends shall be made only with bending tools and procedures intended for that purpose.
2. Bends shall be smooth and free from buckling, cracks or other evidence of mechanical damage.

3. The longitudinal weld of the pipe shall be near the neutral axis of the bend.
4. Pipe shall not be bent through an arc of more than 90 degrees (1.6 rad).
5. The inside radius of a bend shall be not less than six times the outside diameter of the pipe.

G2416.3 ~~(405.3)~~ Plastic pipe. Plastic pipe bends shall comply with the following:

1. The pipe shall not be damaged and the internal diameter of the pipe shall not be effectively reduced.
2. Joints shall not be located in pipe bends.
3. The radius of the inner curve of such bends shall be not less than 25 times the inside diameter of the pipe.
4. Where the *pipng* manufacturer specifies the use of special bending tools or procedures, such tools or procedures shall be used.

SECTION G2417 ~~(406)~~ INSPECTION, TESTING AND PURGING

G2417.1 ~~(406.1)~~ General. Prior to acceptance and initial operation, all *pipng* installations shall be visually inspected and pressure tested to determine that the materials, design, fabrication and installation practices comply with the requirements of this code.

G2417.1.1 ~~(406.1.1)~~ Inspections. Inspection shall consist of visual examination, during or after manufacture, fabrication, assembly or *pressure tests*.

G2417.1.1.1 Rough piping inspection. This inspection shall be made after piping authorized by the permit has been installed and before such piping has been covered or concealed or a fixture or appliance has been attached thereto. This inspection shall include a determination that the gas piping size, material and installation meet the requirements of this chapter.

G2417.1.1.2 Final piping inspection. This inspection shall be made after piping authorized by the permit has been installed and after all portions thereof that are to be covered or concealed are so concealed and after fixtures, appliances or shutoff valves have been attached thereto.

G2417.1.2 ~~(406.1.2)~~ Repairs and additions. In the event repairs or additions are made after the *pressure test*, the affected *pipng* shall be tested.

Minor repairs and additions are not required to be *pressure tested* provided that the work is inspected and connections are tested with a noncorrosive leak-detecting fluid or other *approved* leak-detecting methods.

G2417.1.3 ~~(406.1.3)~~ New branches. Where new branches are installed to new *appliances*, only the newly installed branches shall be required to be *pressure tested*. Connections between the

new *pipng* and the existing *pipng* shall be tested with a noncorrosive leak-detecting fluid or other *approved* leak-detecting methods.

G2417.1.4 ~~(406.1.4)~~ Section testing. A *pipng system* shall be permitted to be tested as a complete unit or in sections. A *valve* in a line shall not be used as a bulkhead between gas in one section of the *pipng system* and test medium in an adjacent section, except where a double block and bleed valve system is installed. A valve shall not be subjected to the test pressure unless it can be determined that the valve, including the valve - closing mechanism, is designed to safely withstand the test pressure.

G2417.1.5 ~~(406.1.5)~~ Regulators and valve assemblies. *Regulator* and valve assemblies fabricated independently of the *pipng system* in which they are to be installed shall be permitted to be tested with inert gas or air at the time of fabrication.

G2417.1.6 ~~(406.1.6)~~ Pipe clearing. Prior to testing, the interior of the pipe shall be cleared of all foreign material.

G2417.2 ~~(406.2)~~ Test medium. The test medium shall be air, nitrogen, carbon dioxide or an inert gas. Oxygen shall not be used as a test medium.

G2417.3 ~~(406.3)~~ Test preparation. *Pipe* joints, including welds, shall be left exposed for examination during the test.

Exception: Covered or *concealed pipe* end joints that have been previously tested in accordance with this *code*.

G2417.3.1 ~~(406.3.1)~~ Expansion joints. Expansion joints shall be provided with temporary restraints, if required, for the additional thrust load under test.

G2417.3.2 ~~(406.3.2)~~ Appliance and equipment isolation. *Appliances* and *equipment* that are not to be included in the test shall be either disconnected from the *pipng* or isolated by blanks, blind flanges or caps.

G2417.3.3 ~~(406.3.3)~~ Appliance and equipment disconnection. Where the *pipng system* is connected to *appliances* or *equipment* designed for operating pressures of less than the test pressure, such *appliances* or *equipment* shall be isolated from the *pipng system* by disconnecting them and capping the *outlet(s)*.

G2417.3.4 ~~(406.3.4)~~ Valve isolation. Where the *pipng system* is connected to *appliances* or *equipment* designed for operating pressures equal to or greater than the test pressure, such *appliances* or *equipment* shall be isolated from the *pipng system* by closing the individual *appliance* or *equipment* shutoff valve(s).

G2417.3.5 ~~(406.3.5)~~ Testing precautions. Testing of *pipng* systems shall be performed in a manner that protects the safety of employees and the public during the test.

~~G2417.4 (406.4) Test pressure measurement.~~ Test pressure shall be measured with a manometer or with a pressure-measuring device designed and calibrated to read, record, or indicate a pressure loss caused by leakage during the *pressure test* period. The source of pressure shall be isolated before the *pressure tests* are made. Mechanical gauges used to measure test pressures shall use a 15-pounds-per-square-inch (103 kPa) gauge or a 30-pounds-per-square-inch (206 kPa) gauge for testing 14 inches water column (3.48 kPa) systems and a 100-pounds-per-square-inch (689 kPa) gauge for testing systems exceeding 14 inches water column (3.48 kPa) operating pressure. The gauges shall not exceed the manufacturer’s listing and labeling have a range such that the highest end of the scale is not greater than five times the test pressure.

G2417.4.1 Test pressure. Gas piping systems under 14 inches w.c. pressure shall be tested at a pressure of not less than 10 pounds per square inch (69 kPa) gauge. Test pressures shall be held for not less than 15 minutes with no perceptible drop in pressure. For welded *piping* and for *piping carrying gas at pressures exceeding 14 inches water column (3.48 kPa) pressure*, the test pressure shall be at least 60 pounds per square inch (414 kPa) for not less than 30 minutes.

Exception: Testing, inspection and purging of gas piping systems performed in accordance with NFPA 58.

~~G2417.4.1 (406.4.1) Test pressure.~~ The test pressure to be used shall be not less than 1½ times the proposed maximum working pressure, but not less than 3 psig (20 kPa gauge), irrespective of design pressure. Where the test pressure exceeds 125 psig (862 kPa gauge), the test pressure shall not exceed a value that produces a hoop stress in the *piping* greater than 50 percent of the specified minimum yield strength of the pipe.

~~G2417.4.2 (406.4.2) Test duration.~~ The test duration shall be not less than 10 minutes.

~~G2417.5 (406.5) Detection of leaks and defects.~~ The *piping system* shall withstand the test pressure specified without showing any evidence of leakage or other defects. Any reduction of test pressures as indicated by pressure gauges shall be deemed to indicate the presence of a leak unless such reduction can be readily attributed to some other cause.

~~G2417.5.1 (406.5.1) Detection methods.~~ The leakage shall be located by means of an *approved* gas detector, a noncorrosive leak detection fluid or other *approved* leak detection methods.

~~G2417.5.2 (406.5.2) Corrections.~~ Where leakage or other defects are located, the affected portion of the *piping system* shall be repaired or replaced and retested.

~~G2417.6 (406.6) Piping system and equipment leakage check.~~ Leakage checking of systems and *equipment* shall be in accordance with Sections G2417.6.1 through G2417.6.4.

~~G2417.6.1 (406.6.1) Test gases.~~ Leak checks using fuel gas shall be permitted in *piping systems* that have been pressure tested in accordance with Section G2417.

~~G2417.6.2 (406.6.2) Before turning gas on.~~ During the process of turning gas on into a system of new *gas piping*, the entire system shall be inspected to determine that there are no open fittings or ends and that all valves at unused outlets are closed and plugged or capped.

~~G2417.6.3 (406.6.3) Leak check.~~ Immediately after the gas is turned on into a new system or into a system that has been initially restored after an interruption of service, the *piping system* shall be checked for leakage. Where leakage is indicated, the gas supply shall be shut off until the necessary repairs have been made.

~~G2417.6.4 (406.6.4) Placing appliances and equipment in operation.~~ Appliances and *equipment* shall not be placed in operation until after the *piping system* has been checked for leakage in accordance with Section G2417.6.3, the *piping system* has been purged in accordance with Section G2417.7 and the connections to the *appliances* have been checked for leakage.

~~G2417.7 (406.7) Purging.~~ The purging of *piping* shall be in accordance with Sections G2417.7.1 through 2417.7.3.

~~G2417.7.1 (406.7.1) Piping systems required to be purged outdoors.~~ The purging of *piping systems* shall be in accordance with the provisions of Sections G2417.7.1.1 through G2417.7.1.4 where the *piping system* meets either of the following:

1. The design operating gas pressure is greater than 2 psig (13.79 kPa).
2. The *piping* being purged contains one or more sections of pipe or tubing meeting the size and length criteria of Table G2417.7.1.1.

~~G2417.7.1.1 (406.7.1.1) Removal from service.~~ Where existing *gas piping* is opened, the section that is opened shall be isolated from the gas supply and the line pressure vented in accordance with Section G2417.7.1.3. Where *gas piping* meeting the criteria of Table G2417.7.1.1 is removed from service, the residual fuel gas in the *piping* shall be displaced with an inert gas.

TABLE G2417.7.1.1 (406.7.1.1)
SIZE AND LENGTH OF PIPING

NOMINAL PIPE SIZE (inches) _a	LENGTH OF PIPING (feet)
≥ 2½ < 3	> 50
≥ 3 < 4	> 30
≥ 4 < 6	> 15
≥ 6 < 8	> 10
≥ 8	Any length

For SI: 1 inch = 25.4 mm, 1 foot = 304.8 mm.

a.—CSST EHD size of 62 is equivalent to nominal 2-inch pipe or tubing size.

~~**G2417.7.1.2 (406.7.1.2) Placing in operation.** Where *gas piping* containing air and meeting the criteria of Table G2417.7.1.1 is placed in operation, the air in the *piping* shall first be displaced with an inert gas. The inert gas shall then be displaced with fuel gas in accordance with Section G2417.7.1.3.~~

~~**G2417.7.1.3 (406.7.1.3) Outdoor discharge of purged gases.** The open end of a *piping* system being pressure vented or purged shall discharge directly to an outdoor location. Purging operations shall comply with all of the following requirements:~~

- ~~1. The point of discharge shall be controlled with a shutoff valve.~~
- ~~2. The point of discharge shall be located not less than 10 feet (3048 mm) from sources of ignition, not less than 10 feet (3048 mm) from building openings and not less than 25 feet (7620 mm) from mechanical air intake openings.~~
- ~~3. During discharge, the open point of discharge shall be continuously attended and monitored with a combustible gas indicator that complies with Section G2417.7.1.4.~~
- ~~4. Purging operations introducing fuel gas shall be stopped when 90 percent fuel gas by volume is detected within the pipe.~~
- ~~5. Persons not involved in the purging operations shall be evacuated from all areas within 10 feet (3048 mm) of the point of discharge.~~

~~**G2417.7.1.4 (406.7.1.4) Combustible gas indicator.** Combustible gas indicators shall be listed and shall be calibrated in accordance with the manufacturer's instructions. Combustible gas indicators shall numerically display a volume scale from zero percent to 100 percent in 1-percent or smaller increments.~~

~~**G2417.7.2 (406.7.2) Piping systems allowed to be purged indoors or outdoors.** The purging of *piping systems* shall be in accordance with the provisions of Section G2417.7.2.1 where the *piping system* meets both of the following:~~

- ~~1. The design operating gas pressure is 2 psig (13.79 kPa) or less.~~
- ~~2. The *piping* being purged is constructed entirely from pipe or tubing not meeting the size and length criteria of Table G2417.7.1.1.~~

~~**G2417.7.2.1 (406.7.2.1) Purging procedure.** The *piping system* shall be purged in accordance with one or more of the following:~~

- ~~1. The *piping* shall be purged with fuel gas and shall discharge to the outdoors.~~
- ~~2. The *piping* shall be purged with fuel gas and shall discharge to the indoors or outdoors through an *appliance* burner not located in a combustion chamber. Such burner shall be provided with a continuous source of ignition.~~

~~3. The *piping* shall be purged with fuel gas and shall discharge to the indoors or outdoors through a burner that has a continuous source of ignition and that is designed for such purpose.~~

~~4. The *piping* shall be purged with fuel gas that is discharged to the indoors or outdoors, and the point of discharge shall be monitored with a listed combustible gas detector in accordance with Section G2417.7.2.2. Purging shall be stopped when fuel gas is detected.~~

~~5. The *piping* shall be purged by the gas supplier in accordance with written procedures.~~

~~**G2417.7.2.2 (406.7.2.2) Combustible gas detector.** Combustible gas detectors shall be listed and shall be calibrated or tested in accordance with the manufacturer's instructions. Combustible gas detectors shall be capable of indicating the presence of fuel gas.~~

~~**G2417.7.3 (406.7.3) Purging appliances and equipment.** After the *piping system* has been placed in operation, *appliances* and *equipment* shall be purged before being placed into operation.~~

~~SECTION G2418 (407)~~ PIPING SUPPORT

~~**G2418.1 (407.1) General.** *Piping* shall be provided with support in accordance with Section G2418.2.~~

~~**G2418.2 (407.2) Design and installation.** *Piping* shall be supported with ~~metal~~ pipe hooks, ~~metal~~ pipe straps, ~~metal~~ bands, ~~metal~~ brackets, ~~metal~~ hangers or building structural components suitable for the size of *piping*, of adequate strength and quality, and located at intervals so as to prevent or damp out excessive vibration. *Piping* shall be anchored to prevent undue strains on connected *appliances* and shall not be supported by other *piping*. Pipe hangers and supports shall conform to the requirements of MSS SP-58 and shall be spaced in accordance with Section G2424. Supports, hangers and anchors shall be installed so as not to interfere with the free expansion and contraction of the *piping* between anchors. The components of the supporting *equipment* shall be designed and installed so that they will not be disengaged by movement of the supported *piping*.~~

~~SECTION G2419 (408)~~ DRIPS AND SLOPED PIPING

~~**G2419.1 (408.1) Slopes.** *Piping* for other than dry gas conditions shall be sloped not less than 1/4 inch in 15 feet (6.3 mm in 4572 mm) to prevent traps.~~

~~**G2419.2 (408.2) Drips.** Where wet gas exists, a *drip* shall be provided at any point in the line of pipe where *condensate* could collect. A *drip* shall be provided at the outlet of the *meter* and shall be installed so as to constitute a trap wherein an accumulation of *condensate* will shut off the flow of gas before the *condensate* will run back into the *meter*.~~

G2419.3 ~~(408.3)~~ Location of drips. *Drips* shall be provided with *ready access* to permit cleaning or emptying. A *drip* shall not be located where the *condensate* is subject to freezing.

G2419.4 ~~(408.4)~~ Sediment trap. Where a sediment trap is not incorporated as part of the appliance, a sediment trap shall be installed downstream of the appliance shutoff valve as close to the inlet of the appliance as practical. The sediment trap shall be either a tee fitting having a capped nipple of any length installed vertically in the bottommost opening of the tee as illustrated in Figure G2419.4 or other device approved as an effective sediment trap. Illuminating appliances, ranges, clothes dryers, decorative vented appliances for installation in vented fireplaces, gas fireplaces and outdoor grills need not be so equipped unless specifically required by the appliance manufacturer's installation instructions.

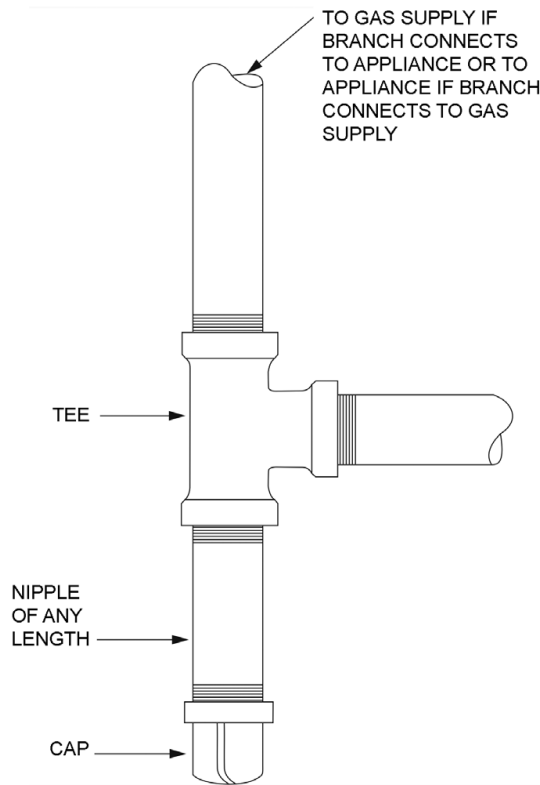

FIGURE G2419.4 ~~(408.4)~~
METHOD OF INSTALLING A TEE FITTING SEDIMENT TRAP

SECTION G2420 ~~(409)~~
SHUTOFF VALVES

G2420.1 ~~(409.1)~~ General. *Piping systems* shall be provided with shutoff valves in accordance with this section.

G2420.1.1 ~~(409.1.1)~~ Valve approval. Shutoff valves shall be of an *approved* type; shall be constructed of materials compatible with the *piping*; and shall comply with the standard that is applicable for the pressure and application, in accordance with Table G2420.1.1.

G2420.1.2 ~~(409.1.2)~~ Prohibited locations. Shutoff valves shall be prohibited in *concealed locations* and *furnace plenums*.

G2420.1.3 ~~(409.1.3)~~ Access to shutoff valves. Shutoff valves shall be located in places so as to provide access for operation and shall be installed so as to be protected from damage.

G2420.2 ~~(409.2)~~ Meter valve. Every *meter* shall be equipped with a shutoff valve located on the supply side of the *meter*.

**TABLE G2420.1.1 (409.1.1)
MANUAL GAS VALVE STANDARDS**

VALVE STANDARDS	APPLIANCE SHUTOFF VALVE APPLICATION UP TO 1/2 psig PRESSURE	OTHER VALVE APPLICATIONS			
		UP TO 1/2 psig PRESSURE	UP TO 2 psig PRESSURE	UP TO 5 psig PRESSURE	UP TO 125 psig PRESSURE
ANSI Z21.15/CGA 9.1	X	—	—	—	—
ASME B16.44	X	X	X ^a	X ^b	—
ASME B16.33	X	X	X	X	X

For SI: 1 pound per square inch gauge = 6.895 kPa.

- a. If labeled 2G.
- b. If labeled 5G.

G2420.3 (409.3.2) Individual buildings. In a common system serving more than one building, shutoff valves shall be installed outdoors at each building.

G2420.4 (409.4) MP regulator valves. A listed shutoff valve shall be installed immediately ahead of each MP regulator.

G2420.5 (409.5) Appliance shutoff valve. Each appliance shall be provided with a shutoff valve in accordance with Section G2420.5.1, G2420.5.2 or G2420.5.3.

G2420.5.1 (409.5.1) Located within same room. The shutoff valve shall be located in the same room as the appliance. The shutoff valve shall be within 6 feet (1829 mm) of the appliance, and shall be installed upstream of the union, connector or quick disconnect device it serves. Such shutoff valves shall be provided with access. Shutoff valves serving movable appliances, such as cooking appliances and clothes dryers, shall be considered to be provided with access where installed behind such appliances. Appliance shutoff valves located in the firebox of a fireplace shall be installed in accordance with the appliance manufacturer’s instructions.

G2420.5.2 (409.5.2) Vented decorative appliances and room heaters. Shutoff valves for vented decorative appliances, room heaters and decorative appliances for installation in vented fireplaces shall be permitted to be installed in an area remote from the appliances where such valves are provided with ready access. Such valves shall be permanently identified and shall not serve another appliance. The piping from the shutoff valve to within 6 feet (1829 mm) of the appliance shall be designed, sized and installed in accordance with Sections G2412 through G2419.

G2420.5.3 (409.5.3) Located at manifold. Where the appliance shutoff valve is installed at a manifold, such shutoff valve shall be located within 50 feet (15 240 mm) of the appliance served and shall be readily accessible and permanently identified. The piping from the manifold to within 6 feet (1829 mm) of the appliance shall be designed, sized and installed in accordance with Sections G2412 through G2419.

G2420.6 (409.7) Shutoff valves in tubing systems. Shutoff valves installed in tubing systems shall be rigidly and securely supported independently of the tubing.

**SECTION G2421 (410)
FLOW CONTROLS**

G2421.1 (410.1) Pressure regulators. A line pressure regulator shall be installed where the appliance is designed to operate at a lower pressure than the supply pressure. Line gas pressure regulators shall be listed as complying with ANSI Z21.80/CSA 6.22. Access shall be provided to pressure regulators. Pressure regulators shall be protected from physical damage. Regulators installed on the exterior of the building shall be approved for outdoor installation.

G2421.2 (410.2) MP regulators. MP pressure regulators shall comply with the following:

1. The MP regulator shall be approved and shall be suitable for the inlet and outlet gas pressures for the application.
2. The MP regulator shall maintain a reduced outlet pressure under lock-up (no-flow) conditions.
3. The capacity of the MP regulator, determined by published ratings of its manufacturer, shall be adequate to supply the appliances served.
4. The MP pressure regulator shall be provided with access. Where located indoors, the regulator shall be vented to the outdoors or shall be equipped with a leak-limiting device, in either case complying with Section G2421.3.
5. A tee fitting with one opening capped or plugged shall be installed between the MP regulator and its upstream shutoff valve. Such tee fitting shall be positioned to allow connection of a pressure-measuring instrument and to serve as a sediment trap.
6. A tee fitting with one opening capped or plugged shall be installed not less than 10 pipe diameters downstream of the MP regulator outlet. Such tee fitting shall be positioned to allow connection of a pressure-measuring instrument. The tee fitting is not required where the MP regulator serves an appliance that has a pressure test port on the gas control inlet side and the appliance is located in the same room as the MP regulator.
7. Where connected to rigid piping, a union shall be installed within 1 foot (304 mm) of either side of the MP regulator.

G2421.3 Liquefied petroleum gas regulators. LP-gas second-stage and 2 pounds per square inch regulators, as defined by NFPA 58, shall be installed in accordance with the following:

1. Regulators installed outdoors shall be protected from motor vehicle impact. For examples of approved types of protection, see Figure M1307.1
2. Regulator vent discharge shall be located not less than 3 feet (914 mm) horizontally from openings below the point of discharge and not less than 5 feet (1525 mm) in any direction from exterior sources of ignition, openings into direct-vent appliances or mechanical ventilation air intakes.
3. Venting of regulators shall comply with Sections G2421.4 and G2421.4.1.

G2421.4 ~~G2421.3 (410.3)~~ Venting of regulators. Pressure regulators that require a vent shall be vented directly to the outdoors. The vent shall be designed to prevent the entry of insects, water and foreign objects.

Exception: A vent to the outdoors is not required for regulators equipped with and labeled for utilization with an approved vent-limiting device installed in accordance with the manufacturer's instructions.

G2421.4.1 ~~G2421.3.1 (410.3.1)~~ Vent piping. Vent piping for relief vents and breather vents shall be constructed of materials allowed for gas piping in accordance with Section G2414. Vent piping shall be not smaller than the vent connection on the pressure-regulating device. Vent piping serving relief vents and combination relief and breather vents shall be run independently to the outdoors and shall serve only a single device vent. ~~Vent piping serving only breather vents is permitted to be connected in a manifold arrangement where sized in accordance with an approved design that minimizes backpressure in the event of diaphragm rupture.~~ Regulator vent piping shall not exceed the length specified in the regulator manufacturer's instructions.

G2421.5 ~~G2421.4 (410.4)~~ Excess flow valves. Where automatic excess flow valves are installed, they shall be listed in accordance with ANSI Z21.93/CSA 6.30 and shall be sized and installed in accordance with the manufacturer's instructions.

G2421.6 ~~G2421.5 (410.5)~~ Flashback arrestor check valve. Where fuel gas is used with oxygen in any hot work operation, a listed protective device that serves as a combination flashback arrestor and backflow check valve shall be installed at an approved location on both the fuel gas and oxygen supply lines. Where the pressure of the piped fuel gas supply is insufficient to ensure such safe operation, approved equipment shall be installed between the gas meter and the appliance that increases pressure to the level required for such safe operation.

SECTION G2422 ~~(411)~~ APPLIANCE CONNECTIONS

G2422.1 ~~(411.1)~~ Connecting appliances. Appliances shall be connected to the piping system by one of the following:

1. Rigid metallic pipe and fittings.
2. Corrugated stainless steel tubing (CSST) where installed in accordance with the manufacturer's instructions.
3. Listed and labeled appliance connectors in compliance with ANSI Z21.24/CSA 6.10 and installed in accordance with the manufacturer's instructions and located entirely in the same room as the appliance.
4. Listed and labeled quick-disconnect devices in compliance with ANSI Z21.41/CSA 6.9 used in conjunction with listed and labeled appliance connectors.
5. Listed and labeled convenience outlets in compliance with ANSI Z21.90/CSA 6.24 used in conjunction with listed and labeled appliance connectors.
6. Listed and labeled outdoor appliance connectors in compliance with ANSI Z21.75/CSA 6.27 and installed in accordance with the manufacturer's instructions.
- ~~7. Listed outdoor gas hose connectors in compliance with ANSI Z21.54 used to connect portable outdoor appliances. The gas hose connection shall be made only in the outdoor area where the appliance is used, and shall be to the gas piping supply at an appliance shutoff valve, a listed quick-disconnect device or listed gas convenience outlet.~~

G2422.1.1 ~~(411.1.2)~~ Protection from damage. Connectors and tubing shall be installed so as to be protected against physical damage.

G2422.1.2 ~~(411.1.3)~~ Connector installation. Appliance fuel connectors shall be installed in accordance with the manufacturer's instructions and Sections G2422.1.2.1 through G2422.1.2.4.

G2422.1.2.1 ~~(411.1.3.1)~~ Maximum length. Connectors shall have an overall length not to exceed 6 feet (1829 mm). Measurement shall be made along the centerline of the connector. Only one connector shall be used for each appliance.

Exception: Rigid metallic piping used to connect an appliance to the piping system shall be permitted to have a total length greater than 6 feet (1829 mm), provided that the connecting pipe is sized as part of the piping system in accordance with Section G2413 and the location of the appliance shutoff valve complies with Section G2420.5.

G2422.1.2.2 ~~(411.1.3.2)~~ Minimum size. Connectors shall have the capacity for the total demand of the connected appliance.

G2422.1.2.3—(411.1.3.3) Prohibited locations and penetrations. Connectors shall not be concealed within, or extended through, walls, floors, partitions, ceilings or *appliance* housings.

Exceptions:

1. Connectors constructed of materials allowed for *pipng systems* in accordance with Section G2414 shall be permitted to pass through walls, floors, partitions and ceilings where installed in accordance with Section G2420.5.2 or G2420.5.3.
2. Rigid steel pipe connectors shall be permitted to extend through openings in *appliance* housings.
3. *Fireplace* inserts that are factory equipped with grommets, sleeves or other means of protection in accordance with the listing of the *appliance*.
4. Semirigid *tubing* and *listed* connectors shall be permitted to extend through an opening in an *appliance* housing, cabinet or casing where the tubing or connector is protected against damage.

G2422.1.2.4 (411.1.3.4) Shutoff valve. A shutoff valve not less than the nominal size of the connector shall be installed ahead of the connector in accordance with Section G2420.5.

G2422.1.3 (411.1.5) Connection of gas engine-powered air conditioners. Internal combustion engines shall not be rigidly connected to the gas supply *pipng*.

G2422.1.4 (411.1.6) Unions. A union fitting shall be provided for *appliances* connected by rigid metallic pipe. Such unions shall be accessible and located within 6 feet (1829 mm) of the *appliance*.

G2422.1.5 (411.1.4) Movable appliances. Where *appliances* are equipped with casters or are otherwise subject to periodic movement or relocation for purposes such as routine cleaning and maintenance, such *appliances* shall be connected to the supply system *pipng* by means of an *appliance connector listed* as complying with ANSI Z21.69/CSA 6.16 or by means of Item 1 of Section G2422.1. Such flexible connectors shall be installed and protected against physical damage in accordance with the manufacturer’s instructions.

G2422.2 (411.3)—Suspended low-intensity infrared tube heaters. Suspended low-intensity infrared tube heaters shall be connected to the building *pipng system* with a connector *listed* for the application complying with ANSI Z21.24/CSA 6.10. The connector shall be installed as specified by the tube heater manufacturer’s instructions.

**SECTION G2423 (413)
COMPRESSED NATURAL GAS MOTOR VEHICLE
FUEL-DISPENSING FACILITIES**

G2423.1 (413.1) General. Motor fuel-dispensing facilities for CNG fuel shall be in accordance with Section 413C413 of the *International Fuel Gas Mechanical Code*.

**SECTION G2424 (415)
PIPING SUPPORT INTERVALS**

G2424.1 (415.1) Interval of support. *Pipng* shall be supported at intervals not exceeding the spacing specified in Table G2424.1. Spacing of supports for CSST shall be in accordance with the CSST manufacturer’s instructions.

**TABLE G2424.1 (415.1)
SUPPORT OF PIPING**

STEEL PIPE, NOMINAL SIZE OF PIPE (inches)	SPACING OF SUPPORTS (feet)	NOMINAL SIZE OF TUBING SMOOTH- WALL (inch O.D.)	SPACING OF SUPPORTS (feet)
1/2	6	1/2	4
3/4 or 1	8	5/8 or 3/4	6
1 1/4 or larger (horizontal)	10	7/8 or 1 (horizontal)	8
1 1/4 or larger (vertical)	Every floor level	1 or larger (vertical)	Every floor level

For SI: 1 inch = 25.4 mm, 1 foot = 304.8 mm.

**SECTION G2425 (501)
GENERAL**

G2425.1 (501.1) Scope. This section shall govern the installation, ~~maintenance~~, repair and approval of factory-built *chimneys*, *chimney* liners, vents and connectors and the utilization of masonry *chimneys* serving gas-fired *appliances*.

G2425.2 (501.2) General. Every *appliance* shall discharge the products of combustion to the outdoors, except for *appliances* exempted by Section G2425.8.

G2425.3 (501.3) Masonry chimneys. *Masonry chimneys* shall be constructed in accordance with Section G2427.5 and Chapter 10.

G2425.4 (501.4) Minimum size of chimney or vent. *Chimneys* and vents shall be sized in accordance with Sections G2427 and G2428.

G2425.5 (501.5) Abandoned inlet openings. Abandoned inlet openings in *chimneys* and vents shall be closed by an *approved* method.

G2425.6 (501.6) Positive pressure. Where an *appliance* equipped with a mechanical forced *draft* system creates a positive pressure in the venting system, the venting system shall be designed for positive pressure applications.

G2425.7 (501.7) Connection to fireplace. Connection of *appliances* to *chimney* flues serving *fireplaces* shall be in accordance with Sections G2425.7.1 through G2425.7.3.

G2425.7.1 (501.7.1) Closure and access. A noncombustible seal shall be provided below the point of connection to prevent entry of room air into the flue. Means shall be provided for *access* to the flue for inspection and cleaning.

G2425.7.2 ~~(501.7.2)~~ **Connection to factory-built fireplace flue.** An *appliance* shall not be connected to a flue serving a *factory-built fireplace* unless the *appliance* is specifically *listed* for such installation. The connection shall be made in accordance with the *appliance* manufacturer's installation instructions.

G2425.7.3 ~~(501.7.3)~~ **Connection to masonry fireplace flue.** A connector shall extend from the *appliance* to the flue serving a *masonry fireplace* such that the *flue gases* are exhausted directly into the flue. The connector shall be accessible or removable for inspection and cleaning of both the connector and the flue. *Listed* direct connection devices shall be installed in accordance with their listing.

G2425.8 ~~(501.8)~~ **Appliances not required to be vented.** The following *appliances* shall not be required to be vented:

1. Ranges.
2. Built-in domestic cooking units *listed* and marked for optional venting.
3. Hot plates and laundry stoves.
4. *Type I clothes dryers* (*Type I clothes dryers* shall be exhausted in accordance with the requirements of Section [G2439 M1502](#)).
5. Refrigerators.
6. Counter *appliances*.
7. Room heaters *listed* for unvented use.

Where the *appliances* listed in Items 5 through 7 are installed so that the aggregate input rating exceeds 20 Btu per hour per cubic foot (207 W/m³) of volume of the room or space in which such *appliances* are installed, one or more shall be provided with venting *systems* or other *approved* means for conveying the *vent gases* to the outdoor atmosphere so that the aggregate input rating of the remaining *unvented appliances* does not exceed 20 Btu per hour per cubic foot (207 W/m³). Where the room or space in which the *appliance* is installed is directly connected to another room or space by a doorway, archway or other opening of comparable size that cannot be closed, the volume of such adjacent room or space shall be permitted to be included in the calculations.

G2425.9 ~~(501.9)~~ **Chimney entrance.** Connectors shall connect to a *masonry chimney* flue at a point not less than 12 inches (305 mm) above the lowest portion of the interior of the *chimney* flue.

G2425.10 ~~(501.10)~~ **Connections to exhauster.** *Appliance* connections to a *chimney* or vent equipped with a power exhauster shall be made on the inlet side of the exhauster. Joints on the positive pressure side of the exhauster shall be sealed to prevent flue-gas leakage as specified by the manufacturer's installation instructions for the exhauster.

G2425.11 ~~(501.11)~~ **Masonry chimneys.** *Masonry chimneys* utilized to vent *appliances* shall be located, constructed and sized as specified in the manufacturer's installation instructions for the *appliances* being vented and Section G2427.

G2425.12 ~~(501.12)~~ **Residential and low-heat appliances flue lining systems.** *Flue lining* systems for use with residential-type and low-heat *appliances* shall be limited to the following:

1. Clay *flue lining* complying with the requirements of ASTM C315 or equivalent. Clay *flue lining* shall be installed in accordance with Chapter 10.
2. *Listed chimney* lining systems complying with UL 1777.
3. Other *approved* materials that will resist, without cracking, softening or corrosion, *flue gases* and *condensate* at temperatures up to 1,800°F (982°C).

G2425.13 ~~(501.13)~~ **Category I appliance flue lining systems.** *Flue lining* systems for use with Category I *appliances* shall be limited to the following:

1. *Flue lining* systems complying with Section G2425.12.
2. *Chimney* lining systems *listed* and *labeled* for use with gas *appliances* with *draft hoods* and other Category I gas *appliances listed* and *labeled* for use with Type B vents.

G2425.14 ~~(501.14)~~ **Category II, III and IV appliance venting systems.** The design, sizing and installation of vents for Category II, III and IV *appliances* shall be in accordance with the *appliance* manufacturer's instructions.

G2425.15 ~~(501.15)~~ **Existing chimneys and vents.** Where an *appliance* is permanently disconnected from an existing *chimney* or vent, or where an *appliance* is connected to an existing *chimney* or vent during the process of a new installation, the *chimney* or vent shall comply with Sections G2425.15.1 through G2425.15.4.

G2425.15.1 ~~(501.15.1)~~ **Size.** The *chimney* or vent shall be resized as necessary to control flue gas condensation in the interior of the *chimney* or vent and to provide the *appliance* or *appliances* served with the required *draft*. For Category I *appliances*, the resizing shall be in accordance with Section G2426.

G2425.15.2 ~~(501.15.2)~~ **Flue passageways.** The flue gas passageway shall be free of obstructions and combustible deposits and shall be cleaned if previously used for venting a solid or liquid fuel-burning *appliance* or *fireplace*. The *flue liner*, *chimney* inner wall or vent inner wall shall be continuous and shall be free of cracks, gaps, perforations, or other damage or deterioration that would allow the escape of *combustion products*, including gases, moisture and creosote.

G2425.15.3 ~~(501.15.3)~~ **Cleanout.** *Masonry chimney* flues shall be provided with a cleanout opening having a minimum height of 6 inches (152 mm). The upper edge of the opening shall be located not less than 6 inches (152 mm) below the lowest *chimney* inlet opening. The cleanout shall be provided with a tight-fitting, noncombustible cover.

G2425.15.4 ~~(501.15.4)~~ **Clearances.** *Chimneys* and vents shall have airspace *clearance* to combustibles in accordance with Chapter 10 and the *chimney* or vent manufacturer's installation instructions.

Exception: *Masonry chimneys* without the required airspace *clearances* shall be permitted to be used if lined or relined with a *chimney lining system listed* for use in *chimneys* with reduced *clearances* in accordance with UL 1777. The *chimney clearance* shall be not less than permitted by the terms of the *chimney liner listing* and the manufacturer's instructions.

G2425.15.4.1 ~~(501.15.4.1)~~ Fireblocking. Noncombustible fireblocking shall be provided in accordance with Chapter 10.

SECTION G2426 ~~(502)~~ VENTS

G2426.1 ~~(502.1)~~ General. Vents, except as provided in Section G2427.7, shall be *listed* and *labeled*. Type B and BW vents shall be tested in accordance with UL 441. Type L vents shall be tested in accordance with UL 641. Vents for Category II and III *appliances* shall be tested in accordance with UL 1738. Plastic vents for Category IV *appliances* shall not be required to be *listed* and *labeled* where such vents are as specified by the *appliance manufacturer* and are installed in accordance with the *appliance manufacturer's instructions*.

G2426.2 ~~(502.2)~~ Connectors required. Connectors shall be used to connect *appliances* to the vertical *chimney* or vent, except where the *chimney* or vent is attached directly to the *appliance*. Vent *connector* size, material, construction and installation shall be in accordance with Section G2427.

G2426.3 ~~(502.3)~~ Vent application. The application of vents shall be in accordance with Table G2427.4.

G2426.4 (502.4) Insulation shield. Where vents pass through insulated assemblies, an insulation shield constructed of steel having a minimum thickness of 0.0187 inch (0.4712 mm) (No. 26 gage) shall be installed to provide *clearance* between the vent and the insulation material. The *clearance* shall be not less than the *clearance* to combustibles specified by the vent manufacturer's installation instructions. Where vents pass through attic space, the shield shall terminate not less than 2 inches (51 mm) above the insulation materials and shall be secured in place to prevent displacement. Insulation shields provided as part of a *listed* vent system shall be installed in accordance with the manufacturer's instructions.

G2426.5 (502.5) Installation. Vent systems shall be sized, installed and terminated in accordance with the vent and *appliance manufacturer's installation instructions* and Section G2427.

G2426.6 (502.6) Support of vents. All portions of vents shall be adequately supported for the design and weight of the materials employed.

G2426.7 ~~(502.7)~~ Protection against physical damage. In *concealed locations*, where a vent is installed through holes or notches in studs, joists, rafters or similar members less than 1½ inches (38 mm) from the nearest edge of the member, the vent shall be protected by shield plates. Protective steel shield plates having a minimum thickness of 0.0575 -inch (1.463 mm) (No. 16

gage) shall cover the area of the vent where the member is notched or bored and shall extend not less than 4 inches (102 mm) above sole plates, below top plates and to each side of a stud, joist or rafter.

G2426.7.1 ~~(502.7.1)~~ Door swing. Appliance and equipment vent terminals shall be located such that doors cannot swing within 12 inches (305 mm) horizontally of the vent terminal. Door stops or closures shall not be installed to obtain this clearance.

SECTION G2427 ~~(503)~~ VENTING OF APPLIANCES

G2427.1 ~~(503.1)~~ General. The venting of appliances shall be in accordance with Sections G2427.2 through G2427.16.

G2427.2 ~~(503.2)~~ Venting systems required. Except as permitted in Sections G2425.8, G2427.2.1 and G2427.2.2, all *appliances* shall be connected to *venting systems*.

G2427.2.1 ~~(503.2.3)~~ Direct-vent appliances. *Listed direct-vent appliances* shall be installed in accordance with the manufacturer's instructions. *Through-the-wall vent terminations for listed direct-vent appliances shall be in accordance with Section G2427.8.*

G2427.2.2 ~~(503.2.4)~~ Appliances with integral vents. *Appliances* incorporating integral venting means shall be installed in accordance with Section G2427.8, Items 1 and 2.

G2427.3 ~~(503.3)~~ Design and construction. Venting systems shall be designed and constructed so as to convey all flue and *vent gases* to the outdoors.

G2427.3.1 ~~(503.3.1)~~ Appliance draft requirements. A venting system shall satisfy the *draft* requirements of the *appliance* in accordance with the manufacturer's instructions.

G2427.3.2 ~~(503.3.2)~~ Design and construction. *Appliances* required to be vented shall be connected to a venting system designed and installed in accordance with the provisions of Sections G2427.4 through G2427.16.

G2427.3.3 ~~(503.3.3)~~ Mechanical draft systems. Mechanical *draft* systems shall comply with the following:

1. Mechanical *draft* systems shall be *listed* in accordance with UL 378 and shall be installed in accordance with the manufacturer's instructions for both the *appliance* and the mechanical *draft* system.
2. *Appliances* requiring venting shall be permitted to be vented by means of mechanical *draft* systems of either forced or induced *draft* design.
3. Forced *draft* systems and all portions of induced *draft* systems under positive pressure during operation shall be designed and installed so as to prevent leakage of flue or *vent gases* into a building.

4. *Vent connectors* serving *appliances* vented by natural *draft* shall not be connected into any portion of mechanical *draft* systems operating under positive pressure.
5. Where a mechanical *draft* system is employed, provisions shall be made to prevent the flow of gas to the *main burners* when the *draft* system is not performing so as to satisfy the operating requirements of the *appliance* for safe performance.

G2427.3.4 (503.3.5) Air ducts and furnace plenums. *Venting systems* shall not extend into or pass through any fabricated air duct or *furnace plenum*.

G2427.3.5 (503.3.6) Above-ceiling air-handling spaces. Where a venting system passes through an above-ceiling air-handling space or other nonducted portion of an air-handling system, the venting system shall conform to one of the following requirements:

1. The venting system shall be a *listed* special gas vent; other venting system serving a Category III or Category IV *appliance*; or other positive pressure vent, with joints sealed in accordance with the *appliance* or vent manufacturer’s instructions.
2. The venting system shall be installed such that fittings and joints between sections are not installed in the above-ceiling space.
3. The venting system shall be installed in a conduit or enclosure with sealed joints separating the interior of the conduit or enclosure from the ceiling space.

G2427.4 (503.4) Type of venting system to be used. The type of venting system to be used shall be in accordance with Table G2427.4.

G2427.4.1 (503.4.1) Plastic piping. Where plastic piping is used to vent an appliance, the appliance shall be listed for use with such venting materials and the appliance manufacturer’s installation instructions shall identify the specific plastic piping material. The plastic pipe venting materials shall be *labeled* in accordance with the product standards specified by the *appliance* manufacturer or shall be *listed* in accordance with UL 1738.

G2427.4.1.1 (503.4.1.1) Plastic vent joints. Plastic *pipe* and fittings used to vent *appliances* shall be installed in accordance with the *appliance* manufacturer’s instructions. Plastic pipe venting materials *listed* and *labeled* in accordance with UL 1738 shall be installed in accordance with the *vent* manufacturer’s instructions. Where a primer is required, it shall be of a contrasting color.

G2427.4.2 (503.4.2) Special gas vent. Special gas *vent* shall be *listed* and *labeled* in accordance with UL 1738 and installed in accordance with the special gas *vent* manufacturer’s instructions.

G2427.5 (503.5) Masonry, metal and factory-built chimneys. Masonry, ~~metal~~ and factory-built *chimneys* shall comply with Sections G2427.5.1 through G2427.5.10.

G2427.5.1 (503.5.1) Factory-built chimneys. Factory-built *chimneys* shall be *listed* in accordance with UL 103. Factory-built *chimneys* used to vent *appliances* that operate at a positive vent pressure shall be *listed* for such application.

**TABLE G2427.4 (503.4)
TYPE OF VENTING SYSTEM TO BE USED**

APPLIANCES	TYPE OF VENTING SYSTEM
Listed Category I appliances Listed appliances equipped with draft hood Appliances listed for use with Type B gas vent	Type B gas vent (Section G2427.6) Chimney (Section G2427.5) Single-wall metal pipe (Section G2427.7) Listed chimney lining system for gas venting (Section G2427.5.2) Special gas vent listed for these appliances (Section G2427.4.2)
Listed vented wall furnaces	Type B-W gas vent (Sections G2427.6, G2436)
Category II, Category III and Category IV appliances	As specified or furnished by manufacturers of listed appliances (Sections G2427.4.1, G2427.4.2)
Unlisted appliances	Chimney (Section G2427.5)
Decorative appliances in vented fireplaces	Chimney
Direct-vent appliances	See Section G2427.2.1
Appliances with integral vent	See Section G2427.2.2

G2427.5.2 (503.5.3) Masonry chimneys. Masonry *chimneys* shall be built and installed in accordance with [NFPA 211 Chapter 10](#) and shall be lined with an *approved clay flue lining*, a *chimney lining system listed and labeled* in accordance with UL 1777 or other *approved* material that will resist corrosion, erosion, softening or cracking from vent gases at temperatures up to 1,800°F (982°C).

Exception: Masonry *chimney* flues serving *listed* gas *appliances* with *draft hoods*, Category I *appliances* and other gas *appliances listed* for use with Type B vents shall be permitted to be lined with a *chimney lining system specifically listed* for use only with such *appliances*. The liner shall be installed in accordance with the liner manufacturer's instructions. A permanent identifying label shall be attached at the point where the connection is to be made to the liner. The label shall read: "This *chimney* liner is for *appliances* that burn gas only. Do not connect to solid or liquid fuel-burning appliances or incinerators."

G2427.5.3 (503.5.4) Chimney termination. *Chimneys* for residential-type or low-heat *appliances* shall extend not less than 3 feet (914 mm) above the highest point where they pass through a roof of a building and not less than 2 feet (610 mm) higher than any portion of a building within a horizontal distance of 10 feet (3048 mm). [\(see Figure G2427.5.3\).](#) *Chimneys* for medium-heat *appliances* shall extend not less than 10 feet (3048 mm) higher than any portion of any building within 25 feet (7620 mm). *Chimneys* shall extend not less than 5 feet (1524 mm) above the highest connected *appliance draft hood* outlet or *flue collar*. Decorative shrouds shall not be installed at the termination of factory-built *chimneys* except where such shrouds are *listed and labeled* for use with the specific factory-built *chimney* system and are installed in accordance with the manufacturer's instructions.

G2427.5.4 (503.5.5) Size of chimneys. The effective area of a *chimney* venting system serving *listed appliances* with *draft hoods*, Category I *appliances*, and other *appliances listed* for use with Type B vents shall be determined in accordance with one of the following methods:

1. The provisions of Section G2428.
2. the effective areas of the *vent connector* and *chimney flue of a venting system serving a single appliance with a draft hood* shall be not less than the area of the *appliance flue collar* or *draft hood* outlet, nor greater than seven times the *draft hood* outlet area.
3. **The effective area of a chimney flue or a venting system serving two appliances with draft hoods.**
4. *Chimney venting systems* using mechanical *draft* shall be sized in accordance with *approved engineering* methods.
5. Other *approved engineering* methods.

G2427.5.5 (503.5.6) Inspection of chimneys. Before replacing an existing *appliance* or connecting a *vent connector* to a *chimney*, the *chimney* passageway shall be examined to ascertain that it is clear and free of obstructions and it shall be cleaned if previously used for venting solid or liquid fuel-burning appliances or *fireplaces*.

G2427.5.5.1 (503.5.6.1) Chimney lining. *Chimneys* shall be lined in accordance with [NFPA 211 Chapter 10](#).

G2427.5.5.2 (503.5.6.2) Cleanouts. Cleanouts shall be ~~examined and where they do not remain tightly closed when not in use, they shall be repaired or replaced~~ [installed in accordance with Chapter 10](#).

G2427.5.5.3 (503.5.6.3) Unsafe chimneys. Where inspection reveals that an existing *chimney* is not safe for the intended application, it shall be repaired, rebuilt, lined, relined or replaced with a *vent* or *chimney* to conform to [NFPA 211 Chapter 10](#) and it shall be suitable for the *appliances* to be vented.

G2427.5.6 (503.5.7) Chimneys serving appliances burning other fuels. *Chimneys* serving *appliances* burning other fuels shall comply with Sections G2427.5.6.1 through G2427.5.6.4.

G2427.5.6.1 (503.5.7.1) Solid fuel-burning appliances. An *appliance* shall not be connected to a *chimney* flue serving a separate *appliance* designed to burn solid fuel.

~~**G2427.5.6.2 (503.5.7.2) Liquid fuel-burning appliances.** Where one *chimney* flue serves gas *appliances* and liquid fuel-burning *appliances*, the *appliances* shall be connected through separate openings or shall be connected through a single opening where joined by a suitable fitting located as close as practical to the *chimney*. Where two or more openings are provided into one *chimney* flue, they shall be at different levels. Where the *appliances* are automatically controlled, they shall be equipped with *safety shutoff devices*.~~

G2427.5.6.2 Common venting of gas utilization equipment and liquid fuel-burning appliances. [The common venting of gas utilization equipment and liquid fuel-burning appliances shall comply with Sections M1804.3.2 and M1804.3.2.1.](#)

G2427.5.6.3 (503.5.7.3) Combination gas- and solid fuel-burning appliances. A combination gas- and solid fuel-burning *appliance* shall be permitted to be connected to a single *chimney* flue where equipped with a manual reset device to shut off gas to the *main burner* in the event of sustained backdraft or flue gas spillage. The *chimney* flue shall be sized to properly vent the *appliance*.

G2427.5.6.4 (503.5.7.4) Combination gas- and oil fuel-burning appliances. Where a single *chimney* flue serves A *listed* combination gas- and oil fuel-burning *appliance*, such flue shall be sized in accordance with the *appliance* manufacturer's instructions.

G2427.5.7—(503.5.8) Support of chimneys. All portions of *chimneys* shall be supported for the design and weight of the materials employed. Factory-built *chimneys* shall be supported and spaced in accordance with the manufacturer's installation instructions.

G2427.5.8 (503.5.9)—Cleanouts. Where a *chimney* that formerly carried flue products from liquid or solid fuel-burning appliances is used with an *appliance* using *fuel gas*, an accessible cleanout shall be provided. The cleanout shall have a tight-fitting cover and be installed so its upper edge is not less than 6 inches (152 mm) below the lower edge of the lowest *chimney* inlet opening.

G2427.5.9 (503.5.10) Space surrounding lining or vent. The remaining space surrounding a *chimney* liner, gas vent, special gas vent or plastic *pipng* installed within a masonry *chimney* flue shall not be used to vent another *appliance*. The insertion of another liner or vent within the *chimney* as provided in this *code* and the liner or vent manufacturer's instructions shall not be prohibited.

The remaining space surrounding a *chimney* liner, gas vent, special gas vent or plastic *pipng* installed within a masonry, metal or factory-built *chimney* shall not be used to supply *combustion air*. Such space shall not be prohibited from supplying *combustion air* to *direct-vent appliances* designed for installation in a solid fuel-burning *fireplace* and installed in accordance with the manufacturer's instructions.

G2427.5.10 (503.5.11) Insulation shield. Where a factory-built *chimney* passes through insulated assemblies, an insulation shield constructed of steel having a thickness of not less than 0.0187 inch (0.475 mm) (nominal 26 gage) shall be installed to provide clearance between the *chimney* and the insulation material. The clearance shall be not less than the clearance to combustibles specified by the *chimney* manufacturer's installation instructions. Where *chimneys* pass through attic space, the shield shall terminate not less than 2 inches (51 mm) above the installation materials and shall be secured in place to prevent displacement.

G2427.6 (503.6) Gas vents. Gas vents shall comply with Sections G2427.6.1 through G2427.6.12. (See Section G2403, General Definitions.)

G2427.6.1 (503.6.1) Materials. Type B and BW gas vents shall be *listed* in accordance with UL 441. Vents for *listed* combination gas- and oil-burning *appliances* shall be *listed* in accordance with UL 641.

G2427.6.2 (503.6.2) Installation, general. Gas vents shall be installed in accordance with the manufacturer's instructions.

G2427.6.3 (503.6.3) Type B-W vent capacity. A Type B-W gas vent shall have a listed capacity not less than that of the *listed vented wall furnace* to which it is connected.

G2427.6.4 (503.6.5) Gas vent terminations. A gas vent shall terminate in accordance with one of the following:

1. Gas vents that are 12 inches (305 mm) or less in size and located not less than 8 feet (2438 mm) from a vertical wall or similar obstruction shall terminate above the roof in accordance with Figure G2427.6.4.
2. Gas vents that are over 12 inches (305 mm) in size or are located less than 8 feet (2438 mm) from a vertical wall or similar obstruction shall terminate not less than 2 feet (610 mm) above the highest point where they pass through the roof and not less than 2 feet (610 mm) above any portion of a building within 10 feet (3048 mm) horizontally.
3. As provided for direct-vent systems in Section G2427.2.1.
4. As provided for *appliances* with integral vents in Section G2427.2.2.
5. As provided for mechanical *draft* systems in Section G2427.3.3.

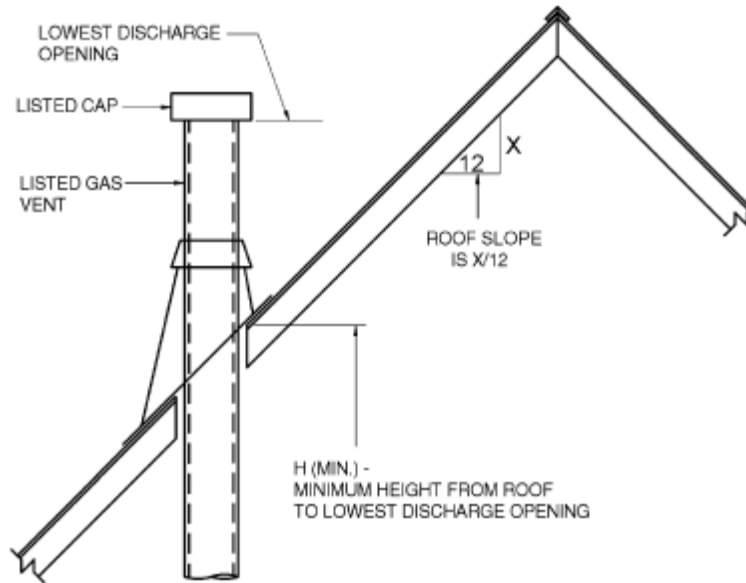

ROOF SLOPE	H (minimum) ft
Flat to 6/12	1.0
Over 6/12 to 7/12	1.25
Over 7/12 to 8/12	1.5
Over 8/12 to 9/12	2.0
Over 9/12 to 10/12	2.5
Over 10/12 to 11/12	3.25
Over 11/12 to 12/12	4.0
Over 12/12 to 14/12	5.0
Over 14/12 to 16/12	6.0
Over 16/12 to 18/12	7.0
Over 18/12 to 20/12	7.5
Over 20/12 to 21/12	8.0

For SI: 1 inch = 25.4 mm, 1 foot = 304.8 mm.

FIGURE G2427.6.4 (503.6.5)
TERMINATION LOCATIONS FOR GAS VENTS WITH LISTED CAPS 12 INCHES OR LESS IN SIZE NOT LESS THAN 8 FEET FROM A VERTICAL WALL

G2427.6.4.1 (503.6.5.1) Decorative shrouds. Decorative shrouds shall not be installed at the termination of gas vents except where such shrouds are *listed* for use with the specific gas venting system and are installed in accordance with manufacturer’s instructions.

G2427.6.5 (503.6.6) Minimum height. A Type B or L gas vent shall terminate not less than 5 feet (1524 mm) in vertical height above the highest connected *appliance draft hood* or *flue collar*. A Type B-W gas vent shall terminate not less than 12 feet (3658 mm) in vertical height above the bottom of the wall *furnace*.

G2427.6.6 (503.6.7) Roof terminations. Gas vents shall extend through the roof flashing, roof jack or roof thimble and terminate with a *listed cap* or *listed roof assembly*.

G2427.6.7 (503.6.8) Forced air inlets. Gas vents shall terminate not less than 3 feet (914 mm) above any forced air inlet located within 10 feet (3048 mm).

G2427.6.8 (503.6.9) Exterior wall penetrations. A gas vent extending through an exterior wall shall not terminate adjacent to the wall or below eaves or parapets, except as provided in Sections G2427.2.1 and G2427.3.3.

G2427.6.9 (503.6.10) Size of gas vents. Venting systems shall be sized and constructed in accordance with Sections G2427.6.9.1 through G2427.6.9.4 and the *appliance manufacturer’s installation instructions*.

G2427.6.9.1 ~~(503.6.10.1)~~–Category I appliances. The sizing of *natural draft venting systems* serving one or more *listed appliances* equipped with a *draft hood* or *appliances listed* for use with Type B gas vent, installed in a single story of a building, shall be in accordance with one of the following methods:

1. The provisions of Section G2428.
2. For sizing an individual gas vent for a single, drafthood-equipped *appliance*, the effective area of the vent *connector* and the gas vent shall be not less than the area of the *appliance draft hood* outlet, nor greater than seven times the *draft hood* outlet area.
3. For sizing a gas vent connected to two *appliances* with *draft hoods*, the effective area of the vent shall be not less than the area of the larger *draft hood* outlet plus 50 percent of the area of the smaller *draft hood* outlet, nor greater than seven times the smaller *draft hood* outlet area.
4. *Approved engineering-methods*.

G2427.6.9.2 ~~(503.6.10.2)~~–Vent offsets. Type B and L vents sized in accordance with Item 2 or 3 of Section G2427.6.8.1 shall extend in a generally vertical direction with offsets not exceeding 45 degrees (0.79 rad), except that a vent system having not more than one 60-degree (1.04 rad) *offset* shall be permitted. Any angle greater than 45 degrees (0.79 rad) from the vertical is considered horizontal. The total horizontal distance of a vent plus the horizontal vent *connector* serving *draft hood*-equipped *appliances* shall be not greater than 75 percent of the vertical height of the vent.

G2427.6.9.3 ~~(503.6.10.3)~~ Category II, III and IV appliances. The sizing of gas vents for Category II, III and IV appliances shall be in accordance with the appliance manufacturer's instructions. The sizing of plastic pipe that is specified by the appliance manufacturer as a venting material for Category II, III and IV appliances, shall be in accordance with the manufacturer's instructions.

G2427.6.9.4 ~~(503.6.10.4)~~–Mechanical draft. *Chimney venting systems* using *mechanical draft* shall be sized in accordance with *approved engineering-methods*.

G2427.6.10 ~~(503.6.12)~~ Support of gas vents. Gas vents shall be supported and spaced in accordance with the manufacturer's installation instructions.

G2427.6.11 ~~(503.6.13)~~ Marking. In those localities where solid and liquid fuels are used extensively, gas vents shall be permanently identified by a label attached to the wall or ceiling at a point where the *vent connector* enters the gas vent. The determination of where such localities exist shall be made by the *building official code official*. The label shall read:

“This gas vent is for *appliances* that burn gas. Do not connect to solid or liquid fuel-burning appliances or incinerators.”

G2427.6.12 ~~(503.6.14)~~ Fastener penetrations. Screws, rivets and other fasteners shall not penetrate the inner wall of double-wall gas vents, except at the transition from an *appliance draft hood* outlet, a *flue collar* or a single-wall metal connector to a double-wall vent.

G2427.7 ~~(503.7)~~ Single-wall metal pipe. Single-wall metal *pipe* vents shall comply with Sections G2427.7.1 through G2427.7.13.

G2427.7.1 ~~(503.7.1)~~–Construction. Single-wall metal pipe shall be constructed of galvanized sheet steel not less than 0.0304 inch (0.7 mm) thick, or other *approved*, noncombustible, corrosion-resistant material.

G2427.7.2 ~~(503.7.2)~~–Cold climate. Uninsulated singlewall metal pipe shall not be used outdoors for venting *appliances* in regions where the 99-percent winter design temperature is below 32°F (0°C).

G2427.7.3 ~~(503.7.3)~~–Termination. Single-wall metal pipe shall terminate not less than 5 feet (1524 mm) in vertical height above the highest connected *appliance draft hood* outlet or *flue collar*. Single-wall metal pipe shall extend not less than 2 feet (610 mm) above the highest point where it passes through a roof of a building and not less than 2 feet (610 mm) higher than any portion of a building within a horizontal distance of 10 feet (3048 mm). An *approved* cap or roof assembly shall be attached to the terminus of a single-wall metal pipe.

G2427.7.4 ~~(503.7.4)~~ Limitations of use. Single-wall metal pipe shall be used only for runs directly from the space in which the *appliance* is located through the roof or exterior wall to the outdoor atmosphere.

G2427.7.5 ~~(503.7.5)~~ Roof penetrations. A pipe passing through a roof shall extend without interruption through the roof flashing, roof jack or roof thimble. Where a single-wall metal pipe passes through a roof constructed of combustible material, a noncombustible, nonventilating thimble shall be used at the point of passage. The thimble shall extend not less than 18 inches (457 mm) above and 6 inches (152 mm) below the roof with the annular space open at the bottom and closed only at the top. The thimble shall be sized in accordance with Section G2427.7.7.

G2427.7.6 ~~(503.7.6)~~–Installation. Single-wall metal pipe shall not originate in any unoccupied attic or concealed -space and shall not pass through any attic, inside wall, concealed space, or floor. The installation of a single-wall metal pipe through an exterior combustible wall shall comply with Section G2427.7.7.

G2427.7.7 ~~(503.7.7)~~–Single-wall penetrations of combustible walls. A Single-wall metal pipe shall not pass through a combustible exterior wall unless guarded at the point of passage by a ventilated metal thimble not smaller than the following:

1. For *listed appliances* with *draft hoods* and *appliances listed* for use with Type B gas vents, the thimble shall be

not less than 4 inches (102 mm) larger in diameter than the metal pipe. Where there is a run of not less than 6 feet (1829 mm) of metal pipe in the open between the *draft hood* outlet and the thimble, the thimble shall be permitted to be not less than 2 inches (51 mm) larger in diameter than the metal pipe.

2. For unlisted *appliances* having *draft hoods*, the thimble shall be not less than 6 inches (152 mm) larger in diameter than the metal pipe.
3. For residential and low-heat *appliances*, the thimble shall be not less than 12 inches (305 mm) larger in diameter than the metal pipe.

Exception: In lieu of thimble protection, all *combustible material* in the wall shall be removed a sufficient distance from the metal pipe to provide the specified *clearance* from such metal pipe to *combustible material*. Any material used to close up such opening shall be noncombustible.

G2427.7.8 ~~(503.7.8)~~ Clearances. Minimum *clearances* from single-wall metal pipe to *combustible material* shall be in accordance with Table G2427.10.5. The *clearance* from single-wall metal pipe to *combustible material* shall be permitted to be reduced where the *combustible material* is protected as specified for *vent connectors* in Table G2409.2.

G2427.7.9 ~~(503.7.9)~~ Size of single-wall metal pipe. A venting system constructed of single-wall metal pipe shall be sized in accordance with one of the following methods and the *appliance* manufacturer's instructions:

1. For a drafthood-equipped *appliance*, in accordance with Section G2428.
2. For a venting system for a single *appliance* with a *draft hood*, the areas of the connector and the pipe each shall be not less than the area of the *appliance flue collar* or *draft hood* outlet, whichever is smaller. The vent area shall be not greater than seven times the *draft hood* outlet

area.

3. *Approved ~~engineering~~ methods.*

G2427.7.10 ~~(503.7.10)~~ Pipe geometry. Any shaped single-wall metal pipe shall be permitted to be used, provided that its equivalent effective area is equal to the effective area of the round pipe for which it is substituted, and provided that the minimum internal dimension of the pipe is not less than 2 inches (51 mm).

G2427.7.11 ~~(503.7.11)~~ Termination capacity. The vent cap or a roof assembly shall have a venting capacity of not less than that of the pipe to which it is attached.

G2427.7.12 ~~(503.7.12)~~ Support of single-wall metal pipe. All portions of single-wall metal pipe shall be supported for the design and weight of the material employed.

G2427.7.13 ~~(503.7.13)~~ Marking. Single-wall metal pipe shall comply with the marking provisions of Section G2427.6.11.

G2427.8 ~~(503.8)~~ Venting system terminal clearances. The clearances for through-the-wall direct-vent and nondirect-vent terminals shall be in accordance with Figure G2427.8 and Table G2427.8.

Exception: The clearances in Table G2427.8 shall not apply to the *combustion air* intake of a direct-vent *appliance*.

G2427.9 ~~(503.9)~~ Condensation drainage. Provisions shall be made to collect and dispose of *condensate* from *venting systems* serving Category II and IV *appliances* and noncategorized condensing *appliances*. *Drains for condensate shall be installed in accordance with the appliance and vent manufacturer's instructions.*

G2427.10 ~~(503.10)~~ Vent connectors for Category I appliances. *Vent connectors* for Category I *appliances* shall comply with Sections G2427.10.1 through G2427.10.14.

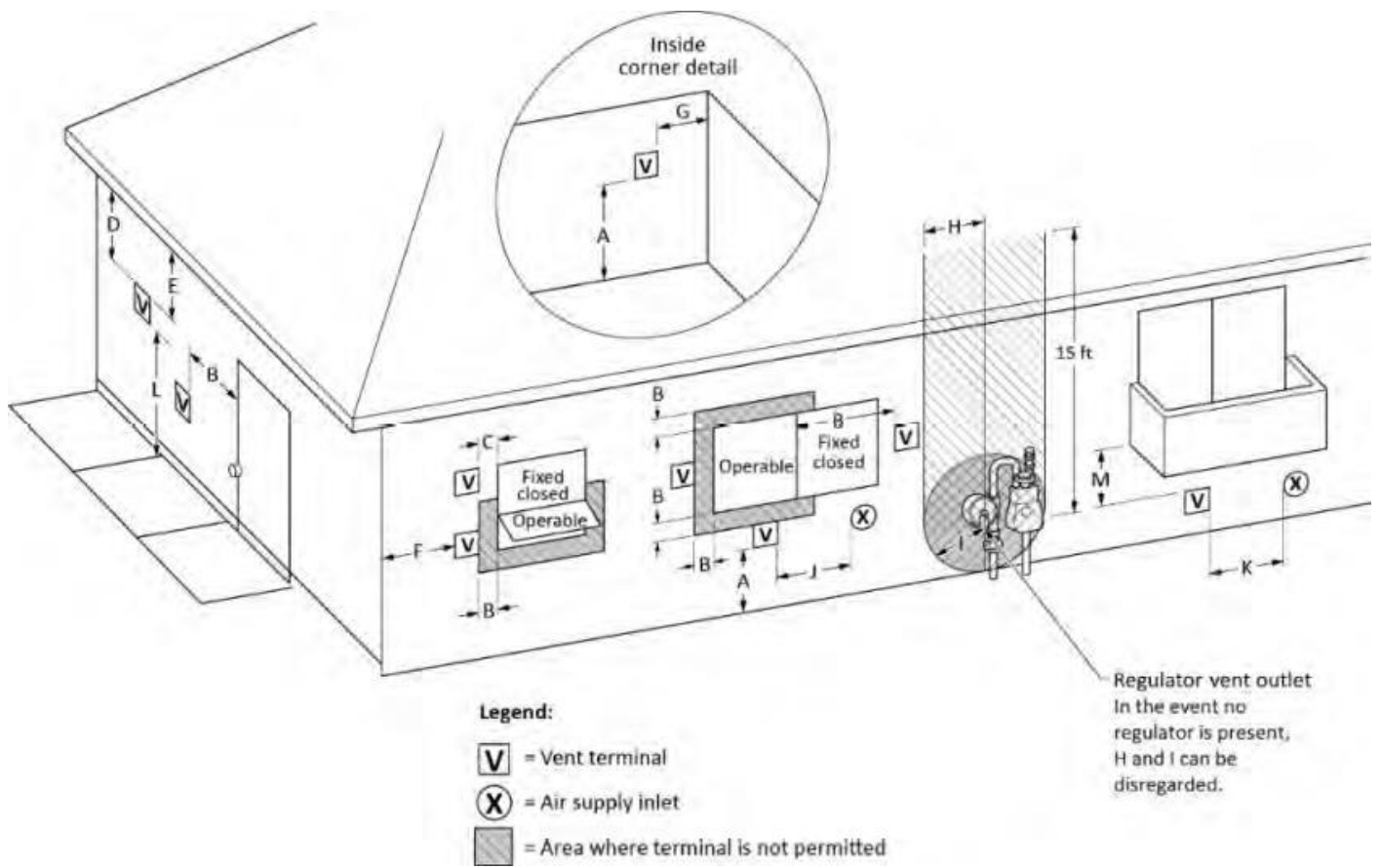

FIGURE G2427.8 (503.8)
THROUGH-THE-WALL VENT TERMINAL CLEARANCES

**TABLE G2427.8 (503.8)
THROUGH-THE-WALL VENT TERMINAL CLEARANCES**

FIGURE CLEARANCE	CLEARANCE LOCATION	MINIMUM CLEARANCES FOR DIRECT-VENT TERMINALS	MINIMUM CLEARANCES FOR NONDIRECT-VENT TERMINALS
A	Clearance above finished grade level, veranda, porch, deck or balcony	12 inches	
B	Clearance to window or door that is openable	6 inches: Appliances ≤ 10,000 Btu/hr 9 inches: Appliances > 10,000 Btu/hr ≤ 50,000 Btu/hr 12 inches: Appliances > 50,000 Btu/hr ≤ 150,000 Btu/hr Appliances > 150,000 Btu/hr, in accordance with the appliance manufacturer’s instructions and not less than the clearances specified for nondirect-vent terminals in Row B	4 feet below or to side of opening or 1 foot above opening
C	Clearance to nonopenable window	None unless otherwise specified by the appliance manufacturer	
D	Vertical clearance to ventilated soffit located above the terminal within a horizontal distance of 2 feet from the centerline of the terminal	None unless otherwise specified by the appliance manufacturer	
E	Clearance to unventilated soffit	None unless otherwise specified by the appliance manufacturer	
F	Clearance to outside corner of building	None unless otherwise specified by the appliance manufacturer	
G	Clearance to inside corner of building	None unless otherwise specified by the appliance manufacturer	
H	Clearance to each side of centerline extended above regulator vent outlet	3 feet up to a height of 15 feet above the regulator vent outlet	
I	Clearance to service regulator vent outlet in all directions	3 feet for gas pressures up to 2 psi; 10 feet for gas pressures above 2 psi	
J	Clearance to nonmechanical air supply inlet to building and the combustion air inlet to any other appliance	Same clearance as specified for Row B	
K	Clearance to a mechanical air supply inlet	10 feet horizontally from inlet or 3 feet above inlet	
L	Clearance above paved sidewalk or paved driveway located on public property	7 feet and shall not be located above public walkways or other areas where condensate or vapor can cause a nuisance or hazard	
M	Clearance to underside of veranda, porch deck or balcony	12 inches where the area beneath the veranda, porch deck or balcony is open on not less than two sides. The vent terminal is prohibited in this location where only one side is open.	

For SI: 1 inch = 25.4 mm, 1 foot = 304.8 mm, 1 pound per square inch = 6.895 kPa, 1 Btu/h = 0.293 W.

G2427.10.1 ~~(503.10.1)~~ Where required. A vent *connector* shall be used to connect an *appliance* to a gas vent, *chimney* or single-wall metal pipe, except where the gas vent, *chimney* or single-wall metal pipe is directly connected to the *appliance*.

G2427.10.2 ~~(503.10.2)~~ Materials. *Vent connectors* shall be constructed in accordance with Sections G2427.10.2.1 through G2427.10.2.4.

G2427.10.2.1 ~~(503.10.2.1)~~ General. A *vent connector* shall be made of noncombustible corrosion-resistant material capable of withstanding the vent gas temperature produced by the *appliance* and of sufficient thickness to withstand physical damage.

G2427.10.2.2 ~~(503.10.2.2)~~ Vent connectors located in unconditioned areas. Where the *vent connector* used for an *appliance* having a *draft hood* or a Category I *appliance* is located in or passes through attics, crawl spaces or other unconditioned spaces, that portion of the *vent connector* shall be *listed* Type B, Type L or listed vent material having equivalent insulation properties.

Exception: Single-wall metal pipe located within the exterior walls of the building in areas having a local 99-percent winter design temperature of 5°F (-15°C) or higher shall be permitted to be used in unconditioned spaces other than attics, garages and crawl spaces.

G2427.10.2.3—(503.10.2.3) Residential-type appliance connectors. Where *vent connectors* for residential-type *appliances* are not installed in attics or other unconditioned spaces, connectors for *listed appliances* having *draft hoods*, *appliances* having *draft hoods* and equipped with *listed conversion burners* and Category I *appliances* shall be one of the following:

1. Type B or L vent material.
2. Galvanized sheet steel not less than 0.018 inch (0.46 mm) thick.
3. Aluminum (1100 or 3003 alloy or equivalent) sheet not less than 0.027 inch (0.69 mm) thick.
4. Stainless steel sheet not less than 0.012 inch (0.31 mm) thick.
5. Smooth interior wall metal pipe having resistance to heat and corrosion equal to or greater than that of Item 2, 3 or 4.
6. A *listed vent connector*.

Vent connectors shall not be covered with insulation.

Exception: *Listed insulated vent connectors* shall be installed in accordance with the manufacturer’s instructions.

G2427.10.2.4 (503.10.2.4) Low-heat appliance. A *vent connector* for a nonresidential, low-heat *appliance* shall be a factory-built *chimney* section or steel *pipe* having resistance to heat and corrosion equivalent to that for the appropriate galvanized pipe as specified in Table G2427.10.2.4. Factory-built *chimney* sections shall be joined together in accordance with the *chimney* manufacturer’s instructions.

**TABLE G2427.10.2.4 (503.10.2.4)
MINIMUM THICKNESS FOR GALVANIZED STEEL VENT
CONNECTORS FOR LOW-HEAT APPLIANCES**

DIAMETER OF CONNECTOR (inches)	MINIMUM THICKNESS (inch)
Less than 6	0.019
6 to less than 10	0.023
10 to 12 inclusive	0.029
14 to 16 inclusive	0.034
Over 16	0.056

For SI: 1 inch = 25.4 mm.

G2427.10.3—(503.10.3) Size of vent connector. *Vent connectors* shall be sized in accordance with Sections G2427.10.3.1 through G2427.3.5.

G2427.10.3.1—(503.10.3.1) Single draft hood and fan-assisted. A *vent connector* for an *appliance* with a single *draft hood* or for a Category I fan-assisted *combustion* system *appliance* shall be sized and installed in accordance with Section G2428 or *approved engineering* methods.

G2427.10.3.2 (503.10.3.2) Multiple draft hood. Where a single *appliance* having more than one *draft hood* outlet or *flue collar* is installed, the manifold shall be constructed according to the instructions of the *appliance* manufacturer. Where there are no instructions, the manifold shall be designed and constructed in accordance with *approved engineering* methods. As an alternate method, the effective area of the manifold shall equal the combined area of the *flue collars* or *draft hood* outlets and the *vent connectors* shall have a rise of not less than 12 inches (305 mm).

G2427.10.3.3 (503.10.3.3) Multiple appliances. Where two or more *appliances* are connected to a common *vent* or *chimney*, each *vent connector* shall be sized in accordance with Section G2428 or *approved engineering* methods.

As an alternative method applicable only where all of the *appliances* are *draft hood* equipped, each *vent connector* shall have an effective area not less than the area of the *draft hood* outlet of the *appliance* to which it is connected.

G2427.10.3.4 (503.10.3.4) Common connector/manifold. Where two or more *appliances* are vented through a common *vent connector* or vent manifold, the common *vent connector* or vent manifold shall be located at the highest level consistent with available headroom and the required clearance to combustible materials and shall be sized in accordance with Section G2428 or *approved engineering* methods.

As an alternate method applicable only where there are two *draft hood*-equipped *appliances*, the effective area of the common *vent connector* or vent manifold and all junction fittings shall be not less than the area of the larger *vent connector* plus 50 percent of the area of the smaller *flue collar* outlet.

G2427.10.3.5 (503.10.3.5) Size increase. Where the size of a *vent connector* is increased to overcome installation limitations and obtain connector capacity equal to the *appliance* input, the size increase shall be made at the *appliance draft hood* outlet.

G2427.10.4 (503.10.4) Two or more appliances connected to a single vent or chimney. Where two or more *vent connectors* enter a common vent, *chimney* flue, or single-wall metal pipe, the smaller connector shall enter at the highest level consistent with the available headroom or clearance to combustible material. *Vent connectors* serving Category I *appliances* shall not be connected to any portion of a *mechanical draft* system operating under positive static pressure, such as those serving Category III or IV *appliances*.

G2427.10.4.1 (503.10.4.1) Two or more openings. Where two or more openings are provided into one *chimney* flue or vent, the openings shall be at different levels, or the connectors shall be attached to the vertical portion of the *chimney* or vent at an angle of 45 degrees (0.79 rad) or less relative to the vertical.

**TABLE G2427.10.5 (503.10.5)
CLEARANCES FOR CONNECTORs^a**

APPLIANCE	MINIMUM DISTANCE FROM COMBUSTIBLE MATERIAL			
	Listed Type B gas vent material	Listed Type L vent material	Single-wall metal pipe	Factory-built chimney sections
Listed appliances with draft hoods and appliances listed for use with Type B gas vents	As listed	As listed	6 inches	As listed
Residential boilers and furnaces with listed gas conversion burner and with draft hood	6 inches	6 inches	9 inches	As listed
Residential appliances listed for use with Type L vents	Not permitted	As listed	9 inches	As listed
Listed gas-fired toilets	Not permitted	As listed	As listed	As listed
Unlisted residential appliances with draft hood	Not permitted	6 inches	9 inches	As listed
Residential and low-heat appliances other than above	Not permitted	9 inches	18 inches	As listed
Medium-heat appliances	Not permitted	Not permitted	36 inches	As listed

For SI: 1 inch = 25.4 mm.

- a. These clearances shall apply unless the manufacturer’s installation instructions for a listed appliance or connector specify different clearances, in which case the listed clearances shall apply.

G2427.10.5 (503.10.5) Clearance. Minimum *clearances* from *vent connectors* to *combustible material* shall be in accordance with Table G2427.10.5.

Exception: The *clearance* between a *vent connector* and *combustible material* shall be permitted to be reduced where the *combustible material* is protected as specified for *vent connectors* in Table G2409.2.

G2427.10.6 (503.10.6) Joints. Joints between sections of connector *piping* and connections to *flue collars* and *draft hood* outlets shall be fastened by one of the following methods:

1. Sheet metal screws.
2. *Vent connectors* of *listed vent material* assembled and connected to *flue collars* or *draft hood* outlets in accordance with the manufacturer’s instructions.
3. Other *approved* means.

G2427.10.7 (503.10.7) Connector junctions. Where *vent connectors* are joined together, the connection shall be made with a tee or wye fitting manufactured for the purpose.

G2427.10.8 (503.10.8) Slope. A *vent connector* shall be installed without dips or sags and shall slope upward toward the vent or *chimney* not less than 1/4 inch per foot (21 mm/m).

Exception: *Vent connectors* attached to a mechanical *draft* system installed in accordance with the *appliance* and *draft* system manufacturers’ instructions.

G2427.10.9 (503.10.9) Length of vent connector. The maximum horizontal length of a single-wall connector shall be 75 percent of the height of the *chimney* or vent—~~except for engineered systems~~ unless otherwise approved. The maximum horizontal length of a Type B double-wall connector shall be 100 percent of the height of the *chimney* or vent—~~except for engineered systems~~ unless otherwise approved.

G2427.10.10 (503.10.10) Support. A *vent connector* shall be supported for the design and weight of the material employed to maintain *clearances* and prevent physical damage and separation of joints.

G2427.10.11 (503.10.11) Chimney connection. Where entering a flue in a masonry or metal *chimney*, the *vent connector* shall be installed above the extreme bottom to avoid stoppage. Where a thimble or slip joint is used to facilitate removal of the connector, the connector shall be firmly attached to or inserted into the thimble or slip joint to prevent the connector from falling out. Means shall be employed to prevent the connector from entering so far as to restrict the space between its end and the opposite wall of the *chimney* flue (see Section G2425.9).

G2427.10.12 (503.10.12) Inspection. The entire length of a *vent connector* shall be provided with *ready access* for inspection, cleaning and replacement.

G2427.10.13 (503.10.13) Fireplaces. A *vent connector* shall not be connected to a *chimney* flue serving a *fireplace* unless the *fireplace* flue opening is permanently sealed.

G2427.10.14 (503.10.14) Passage through ceilings, floors or walls. Single-wall metal pipe connectors shall not pass through any wall, floor or ceiling except as permitted by Section G2427.7.4.

G2427.11 (503.11) Vent connectors for Category II, III and IV appliances. *Vent connectors* for Category II, III and IV *appliances* shall be as specified for the *venting systems* in accordance with Section G2427.4.

G2427.12 (503.12) Draft hoods and draft controls. The installation of *draft hoods* and *draft controls* shall comply with Sections G2427.12.1 through G2427.12.7.

G2427.12.1 ~~(503.12.1)~~ Appliances requiring draft hoods. *Vented appliances* shall be installed with *draft hoods*.

Exception: Dual oven-type combination ranges; *direct-vent appliances*; fan-assisted *combustion system appliances*; *appliances* requiring *chimney draft* for operation; single firebox boilers equipped with *conversion burners* with inputs greater than 400,000 *Btu* per hour (117 kW); *appliances* equipped with blast, power or pressure *burners* that are not *listed* for use with *draft hoods*; and *appliances* designed for forced venting.

G2427.12.2 ~~(503.12.2)~~ Installation. A *draft hood* supplied with or forming a part of a *listed vented appliance* shall be installed without *alteration*, exactly as furnished and specified by the *appliance* manufacturer.

G2427.12.2.1 ~~(503.12.2.1)~~ Draft hood required. If a *draft hood* is not supplied by the *appliance* manufacturer where one is required, a *draft hood* shall be installed, shall be of a *listed* or *approved* type and, in the absence of other instructions, shall be of the same size as the *appliance flue* collar. Where a *draft hood* is required with a *conversion burner*, it shall be of a *listed* or *approved* type.

G2427.12.3 ~~(503.12.3)~~ Draft control devices. Where a *draft control* device is part of the *appliance* or is supplied by the *appliance* manufacturer, it shall be installed in accordance with the manufacturer's instructions. In the absence of manufacturer's instructions, the device shall be attached to the *flue collar* of the *appliance* or as near to the *appliance* as practical.

G2427.12.4 ~~(503.12.4)~~ Additional devices. *Appliances* requiring a controlled *chimney draft* shall be permitted to be equipped with a *listed* double-acting barometric-*draft regulator* installed and adjusted in accordance with the manufacturer's instructions.

G2427.12.5 ~~(503.12.5)~~ Location. *Draft hoods* and *barometric draft regulators* shall be installed in the same room or enclosure as the *appliance* in such a manner as to prevent any difference in pressure between the hood or *regulator* and the *combustion air* supply.

G2427.12.6 ~~(503.12.6)~~ Positioning. *Draft hoods* and *draft regulators* shall be installed in the position for which they were designed with reference to the horizontal and vertical planes and shall be located so that the *relief opening* is not obstructed by any part of the *appliance* or adjacent construction. The *appliance* and its *draft hood* shall be located so that the *relief opening* is accessible for checking *vent* operation.

G2427.12.7 ~~(503.12.7)~~ Clearance. A *draft hood* shall be located so its *relief opening* is not less than 6 inches (152 mm) from any surface except that of the *appliance* it serves and the venting system to which the *draft hood* is connected. Where a greater or lesser *clearance* is indicated on the *appliance* label, the *clearance* shall be not less than that specified on the label. Such *clearances* shall not be reduced.

G2427.13 ~~(503.13)~~ Manually operated dampers. A manually operated *damper* shall not be placed in the *vent connector* for any *appliance*. Fixed **baffles** and **balancing baffles** shall not be classified as manually operated *dampers*.

G2427.13.1 (503.13.1) Balancing baffles. **Balancing baffles** shall be *listed* in accordance with UL 378 and shall be **mechanically locked in the desired position before placing the appliance in operation.**

G2427.14 ~~(503.14)~~ Automatically operated vent dampers. An automatically operated vent damper shall be *listed*.

G2427.15 ~~(503.15)~~ Obstructions. Devices that retard the flow of *vent gases* shall not be installed in a *vent connector*, *chimney* or *vent*. The following shall not be considered as obstructions:

1. *Draft regulators* and *safety controls* specifically listed for installation in *venting systems* and installed in accordance with the manufacturer's instructions.
2. *Approved draft regulators* and *safety controls* that are designed and installed in accordance with **approved engineering** methods.
3. *Listed heat reclaimers* and automatically operated vent dampers installed in accordance with the manufacturer's instructions.
4. *Approved economizers*, *heat reclaimers* and *recuperators* installed in *venting systems* of *appliances* not required to be equipped with *draft hoods*, provided that the *appliance* manufacturer's instructions cover the installation of such a device in the venting system and performance in accordance with Sections G2427.3 and G2427.3.1 is obtained.
5. *Vent dampers* serving *listed appliances* installed in accordance with Sections G2428.2.1 and G2428.3.1 or **approved engineering** methods.

G2427.16 ~~(503.16)~~ (IFGS) Outside wall penetrations. Where vents, including those for *direct-vent appliances*, penetrate outside walls of buildings, the annular spaces around such penetrations shall be permanently sealed using *approved* materials to prevent entry of *combustion products* into the building.

SECTION G2428 ~~(504)~~ SIZING OF CATEGORY I APPLIANCE VENTING SYSTEMS

G2428.1 ~~(504.1)~~ Definitions. The following definitions apply to the tables in this section:

APPLIANCE CATEGORIZED VENT DIAMETER/AREA. The minimum vent area/diameter permissible for Category I *appliances* to maintain a nonpositive vent static pressure when tested in accordance with nationally recognized standards.

FAN + FAN. The maximum combined *appliance* input rating of two or more Category I fan-assisted *appliances* attached to the common vent.

FAN Max. The maximum input rating of a Category I fan-assisted *appliance* attached to a vent or connector.

FAN Min. The minimum input rating of a Category I fan-assisted *appliance* attached to a vent or connector.

FAN + NAT. The maximum combined *appliance* input rating of one or more Category I fan-assisted *appliances* and one or more Category I draft hood-equipped appliances attached to the common vent.

FAN-ASSISTED COMBUSTION SYSTEM. An *appliance* equipped with an integral mechanical means to either draw or force products of *combustion* through the *combustion chamber* or heat exchanger.

NA. Vent configuration is not allowed due to potential for *condensate* formation or pressurization of the venting system, or not applicable due to physical or geometric restraints.

NAT Max. The maximum input rating of a Category I draft hood-equipped appliance attached to a vent or connector.

NAT + NAT. The maximum combined *appliance* input rating of two or more Category I draft-hood-equipped *appliances* attached to the common vent.

G2428.2 (504.2)-Application of single -appliance vent Tables G2428.2(1) and G2428.2(2). The application of Tables G2428.2(1) and G2428.2(2) shall be subject to the requirements of Sections G2428.2.1 through G2428.2.17.

G2428.2.1-(504.2.1) Vent obstructions. These venting tables shall not be used where obstructions, as described in Section G2427.15, are installed in the venting system. The installation of vents serving *listed appliances* with vent dampers shall be in accordance with the *appliance* manufacturer's instructions or in accordance with the following:

1. The maximum capacity of the vent system shall be determined using the "NAT Max" column.
2. The minimum capacity shall be determined as if the *appliance* were a fan-assisted *appliance*, using the "FAN Min" column to determine the minimum capacity of the vent system. Where the corresponding "FAN Min" is "NA," the vent configuration shall not be permitted and an alternative venting configuration shall be utilized.

G2428.2.2 (504.2.2)-Minimum size. Where the vent size determined from the tables is smaller than the *appliance draft hood outlet* or *flue collar*, the smaller size shall be permitted to be used provided that all of the following requirements are met:

1. The total vent height (H) is not less than 10 feet (3048 mm).
2. Vents for *appliance draft hood* outlets or *flue collars* 12 inches (305 mm) in diameter or smaller are not reduced more than one table size.
3. Vents for *appliance draft hood* outlets or *flue collars* larger than 12 inches (305 mm) in diameter are not reduced more than two table sizes.

4. The maximum capacity listed in the tables for a fan-assisted *appliance* is reduced by 10 percent ($0.90 \times$ maximum table capacity).
5. The *draft hood* outlet is greater than 4 inches (102 mm) in diameter. Do not connect a 3-inch-diameter (76 mm) vent to a 4-inch-diameter (102 mm) *draft hood* outlet. This provision shall not apply to fan-assisted *appliances*.

G2428.2.3 (504.2.3)-Vent offsets. Single-*appliance* venting configurations with zero (0) lateral lengths in Tables G2428.2(1) and G2428.2(2) shall not have elbows in the *venting system*. Single-*appliance* venting configurations with lateral lengths include two 90-degree (1.57 rad) elbows. For each additional elbow up to and including 45 degrees (0.79 rad), the maximum capacity listed in the venting tables shall be reduced by 5 percent. For each additional elbow greater than 45 degrees (0.79 rad) up to and including 90 degrees (1.57 rad), the maximum capacity listed in the venting tables shall be reduced by 10 percent. Where multiple *offsets* occur in a vent, the total lateral length of all *offsets* combined shall not exceed that specified in Tables G2428.2(1) and G2428.2(2).

G2428.2.4 (504.2.4) Zero lateral. Zero (0) lateral (L) shall apply only to a straight vertical vent attached to a top outlet *draft hood* or *flue collar*.

G2428.2.5 (504.2.5) High-altitude installations. Sea-level input ratings shall be used when determining maximum capacity for high-altitude installation. Actual input, derated for altitude, shall be used for determining minimum capacity for high-altitude installation.

G2428.2.6 (504.2.6) Multiple input rate appliances. For *appliances* with more than one input rate, the minimum vent capacity (FAN Min) determined from the tables shall be less than the lowest *appliance* input rating, and the maximum vent capacity (FAN Max/NAT Max) determined from the tables shall be greater than the highest *appliance* rating input.

G2428.2.7 (504.2.7) Liner system sizing and connections. *Listed* corrugated metallic *chimney* liner systems in masonry *chimneys* shall be sized by using Table G2428.2(1) or G2428.2(2) for Type B vents with the maximum capacity reduced by 20 percent ($0.80 \times$ maximum capacity) and the minimum capacity as shown in Table G2428.2(1) or G2428.2(2). Corrugated metallic liner systems installed with bends or offsets shall have their maximum capacity further reduced in accordance with Section G2428.2.3. The 20-percent reduction for corrugated metallic *chimney* liner systems includes an allowance for one long-radius 90-degree (1.57 rad) turn at the bottom of the liner.

Connections between *chimney* liners and listed doublewall connectors shall be made with listed adapters designed for such purpose.

G2428.2.8 ~~(504.2.8)~~—Vent area and diameter. Where the vertical vent has a larger diameter than the *vent connector*, the vertical vent diameter shall be used to determine the minimum vent capacity, and the connector diameter shall be used to determine the maximum vent capacity. The flow area of the

vertical vent shall not exceed seven times the flow area of the listed *appliance* categorized vent area, *flue collar* area, or *draft hood* outlet area unless designed in accordance with *approved engineering* methods.

**TABLE G2428.2(1) ~~[504.2(1)]~~
TYPE B DOUBLE-WALL GAS VENT**

For SI: 1 inch = 25.4 mm, 1 foot = 304.8 mm, 1 British thermal unit per hour = 0.2931 W.

**TABLE G2428.2(2) ~~[504.2(2)]~~
TYPE B DOUBLE-WALL GAS VENT**

(continued)

**TABLE G2428.2(2) ~~[504.2(2)]~~—continued
TYPE B DOUBLE-WALL GAS VENT**

For SI: 1 inch = 25.4 mm, 1 foot = 304.8 mm, 1 British thermal unit per hour = 0.2931 W.

G2428.2.9 ~~(504.2.9)~~ Chimney and vent locations. Tables G2428.2(1) and G2428.2(2) shall be used only for chimneys and vents not exposed to the outdoors below the roof line. A Type B vent or listed chimney lining system passing through an unused masonry chimney flue shall not be considered to be exposed to the outdoors. Where vents extend outdoors above the roof more than 5 feet (1524 mm) higher than required by Figure G2427.6.4, and where vents terminate in accordance with Section G2427.6.4, Item 2, the outdoor portion of the vent shall be enclosed as required by this section for vents not considered to be exposed to the outdoors or such venting system shall be an approved design engineered. A Type B vent shall not be considered to be exposed to the outdoors where it passes through an unventilated enclosure or chase insulated to a value of not less than R-8.

G2428.2.10 ~~(504.2.10)~~ Corrugated vent connector size. Corrugated *vent connectors* shall be not smaller than the listed *appliance* categorized *vent* diameter, *flue collar* diameter, or *draft hood* outlet diameter.

G2428.2.11 ~~(504.2.11)~~ Vent connector size limitation. *Vent connectors* shall not be increased in size more than two sizes greater than the listed *appliance* categorized vent diameter, *flue collar* diameter or *draft hood* outlet diameter.

G2428.2.12 ~~(504.2.12)~~ Component commingling. In a single run of vent or *vent connector*, different diameters and types of vent and connector components shall be permitted to be used, provided that all such sizes and types are permitted by the tables.

G2428.2.13 ~~(504.2.13)~~ Draft hood conversion accessories. *Draft hood* conversion accessories for use with *masonry chimneys* venting listed Category I fan-assisted *appliances* shall be listed and installed in accordance with the manufacturer’s instructions for such listed accessories.

G2428.2.14 ~~(504.2.14)~~ Table interpolation. Interpolation shall be permitted in calculating capacities for vent dimensions that fall between the table entries.

G2428.2.15 ~~(504.2.15)~~ Extrapolation prohibited. Extrapolation beyond the table entries shall not be permitted.

G2428.2.16 ~~(504.2.16)~~ Engineering-Design calculations. Where a vent height is less than 6 feet (1829 mm) or greater than shown in the tables, an engineering-approved method shall be used to calculate the vent capacity.

G2428.2.17 ~~(504.2.17)~~ Height entries. Where the actual height of a vent falls between entries in the height column of the applicable table in Tables G2428.2(1) and G2428.2(2), either interpolation shall be used or the lower appliance input rating shown in the table entries shall be used for FAN Max and NAT Max column values and the higher appliance input rating shall be used for the FAN MIN column values.

G2428.3 ~~(504.3)~~ Application of multiple appliance vent Tables G2428.3(1) through G2428.3(4). The application of Tables G2428.3(1) through G2428.3(4) shall be subject to the requirements of Sections G2428.3.1 through G2428.3.24.

G2428.3.1 ~~(504.3.1)~~ Vent obstructions. These venting tables shall not be used where obstructions, as described in Section G2427.15, are installed in the venting system. The installation of vents serving listed *appliances* with vent dampers shall be in accordance with the *appliance* manufacturer’s instructions or in accordance with the following:

1. The maximum capacity of the *vent connector* shall be determined using the NAT Max column.
2. The maximum capacity of the vertical vent or *chimney* shall be determined using the FAN + NAT column where the second *appliance* is a fan-assisted *appliance*, or the NAT + NAT column where the second *appliance* is equipped with a *draft hood*.
3. The minimum capacity shall be determined as if the *appliance* were a fan-assisted *appliance*.
 - 3.1. The minimum capacity of the *vent connector* shall be determined using the FAN Min column.
 - 3.2. The FAN + FAN column shall be used where the second *appliance* is a fan-assisted *appliance*, and the FAN + NAT column shall be used where the second *appliance* is equipped with a *draft hood*, to determine whether the vertical vent or *chimney* configuration is not permitted (NA). Where the vent configuration is NA, the vent configuration shall not be permitted and an alternative venting configuration shall be utilized.

G2428.3.2 ~~(504.3.2)~~ Connector length limit. The *vent connector* shall be routed to the vent utilizing the shortest possible route. Except as provided in Section G2428.3.3, the maximum *vent connector* horizontal length shall be 11/2 feet for each inch (18 mm per mm) of connector diameter as shown in Table G2428.3.2.

TABLE G2428.3.2 ~~(504.3.2)~~
MAXIMUM VENT CONNECTOR LENGTH

CONNECTOR DIAMETER (inches)	CONNECTOR MAXIMUM HORIZONTAL LENGTH (feet)
3	4½
4	6
5	7½
6	9
7	10½
8	12
9	13½

For SI: 1 inch = 25.4 mm, 1 foot = 304.8 mm.

**TABLE G2428.3(1)-[504.3(1)]
TYPE B DOUBLE-WALL VENT**

For SI: 1 inch = 25.4 mm, 1 foot = 304.8 mm, 1 British thermal unit per hour = 0.2931 W.

**TABLE G2428.3(2)-[504.3(2)]
TYPE B DOUBLE-WALL VENT**

For SI: 1 inch = 25.4 mm, 1 foot = 304.8 mm, 1 British thermal unit per hour = 0.2931 W.

**TABLE G2428.3(3)-[504.3(3)]
MASONRY CHIMNEY**

For SI: 1 inch = 25.4 mm, 1 square inch = 645.16 mm², 1 foot = 304.8 mm, 1 British thermal unit per hour = 0.2931 W.

**TABLE G2428.3(4)-[504.3(4)]
MASONRY CHIMNEY**

For SI: 1 inch = 25.4 mm, 1 square inch = 645.16 mm², 1 foot = 304.8 mm, 1 British thermal unit per hour = 0.2931 W.

G2428.3.3—(504.3.3) Connectors with longer lengths. Connectors with longer horizontal lengths than those listed in Section G2428.3.2 are permitted under the following conditions:

1. The maximum capacity (FAN Max or NAT Max) of the *vent connector* shall be reduced 10 percent for each additional multiple of the length allowed by Section G2428.3.2. For example, the maximum length listed in Table G2428.3.2 for a 4-inch (102 mm) connector is 6 feet (1829 mm). With a connector length greater than 6 feet (1829 mm) but not exceeding 12 feet (3658 mm), the maximum capacity must be reduced by 10 percent ($0.90 \times$ maximum *vent connector* capacity). With a connector length greater than 12 feet (3658 mm), but not exceeding 18 feet (5486 mm), the maximum capacity must be reduced by 20 percent ($0.80 \times$ maximum *vent capacity*).
2. For a connector serving a fan-assisted *appliance*, the minimum capacity (FAN Min) of the connector shall be determined by referring to the corresponding single-*appliance* table. For Type B double-wall connectors, Table G2428.2(1) shall be used. For single-wall connectors, Table G2428.2(2) shall be used. The height (*H*) and lateral (*L*) shall be measured according to the procedures for a single-*appliance* vent, as if the other *appliances* were not present.

G2428.3.4 (504.3.4) Vent connector manifold. Where the *vent connectors* are combined prior to entering the vertical portion of the common vent to form a common vent manifold, the size of the common vent manifold and the common vent shall be determined by applying a 10-percent reduction ($0.90 \times$ maximum common vent capacity) to the common vent capacity part of the common vent tables. The length of the common *vent connector* manifold (*L_m*) shall not exceed $1\frac{1}{2}$ feet for each inch (18 mm per mm) of common *vent connector* manifold diameter (*D*).

G2428.3.5 (504.3.5) Common vertical vent offset. Where the common vertical vent is *offset*, the maximum capacity of the common vent shall be reduced in accordance with Section G2428.3.6. The horizontal length of the common vent *offset* (*L_o*) shall not exceed $1\frac{1}{2}$ feet for each inch (18 mm per mm) of common vent diameter (*D*). Where multiple *offsets* occur in a common vent, the total horizontal length of all *offsets* combined shall not exceed $1\frac{1}{2}$ feet for each inch (18 mm per mm) of the common vent diameter (*D*).

G2428.3.6 (504.3.6) Elbows in vents. For each elbow up to and including 45 degrees (0.79 rad) in the common vent, the maximum common vent capacity listed in the venting tables shall be reduced by 5 percent. For each elbow greater than 45 degrees (0.79 rad) up to and including 90 degrees (1.57 rad), the maximum common vent capacity listed in the venting tables shall be reduced by 10 percent.

G2428.3.7—(504.3.7) Elbows in connectors. The *vent connector* capacities listed in the common vent sizing tables include allowance for two 90-degree (1.57 rad) elbows. For each additional elbow up to and including 45 degrees (0.79 rad), the maximum *vent connector* capacity listed in the venting tables shall be reduced by 5 percent. For each elbow greater than 45 degrees (0.79 rad) up to and including 90 degrees (1.57 rad), the maximum *vent connector* capacity listed in the venting tables shall be reduced by 10 percent.

G2428.3.8 (504.3.8) Common vent minimum size. The cross-sectional area of the common vent shall be equal to or greater than the cross-sectional area of the largest connector.

G2428.3.9 (504.3.9) Common vent fittings. At the point where tee or wye fittings connect to a common vent, the opening size of the fitting shall be equal to the size of the common vent. Such fittings shall not be prohibited from having reduced-size openings at the point of connection of *appliance vent connectors*.

G2428.3.9.1 (504.3.9.1) Tee and wye fittings. Tee and wye fittings connected to a common gas vent shall be considered to be part of the common gas vent and shall be constructed of materials consistent with that of the common gas vent.

G2428.3.10 (504.3.10) High-altitude installations. Sea-level input ratings shall be used when determining maximum capacity for high-altitude installation. Actual input, derated for altitude, shall be used for determining minimum capacity for high-altitude installation.

G2428.3.11—(504.3.11) Connector rise measurement. Connector rise (*R*) for each *appliance connector* shall be measured from the *draft hood* outlet or *flue collar* to the centerline where the vent gas streams come together.

G2428.3.12—(504.3.12) Vent height measurement. For multiple *appliances* all located on one floor, available total height (*H*) shall be measured from the highest *draft hood* outlet or *flue collar* up to the level of the outlet of the common vent.

G2428.3.13 (504.3.17) Vertical vent maximum size. Where two or more *appliances* are connected to a vertical vent or *chimney*, the flow area of the largest section of vertical vent or *chimney* shall not exceed seven times the smallest listed *appliance* categorized vent areas, *flue collar* area, or *draft hood* outlet area unless designed in accordance with *approved engineering* methods.

G2428.3.14 (504.3.18) Multiple input rate appliances. The minimum *vent connector* capacity (FAN Min) For *appliances* with more than one input rate shall be determined from the tables and shall be less than the lowest *appliance* input rating. the maximum *vent connector* capacity (FAN Max or NAT Max) for *appliances* with more than one input rate shall be determined from the tables and shall be greater than the highest *appliance* input rating.

G2428.3.15–(504.3.19) Liner system sizing and connections.

Listed, corrugated metallic *chimney* liner systems in masonry *chimneys* shall be sized by using Table G2428.3(1) or G2428.3(1) for Type B vents, with the maximum capacity reduced by 20 percent ($0.80 \times$ maximum capacity) and the minimum capacity as shown in Table G2428.3(1) or G2428.3(1). Corrugated metallic liner systems installed with bends or offsets shall have their maximum capacity further reduced in accordance with Sections G2428.3.5 and G2428.3.6. The 20-percent reduction for corrugated metallic *chimney* liner systems includes an allowance for one long-radius 90-degree (1.57 rad) turn at the bottom of the liner. Where double-wall connectors are required, tee and wye fittings used to connect to the common vent *chimney* liner shall be listed double-wall fittings. Connections between *chimney* liners and listed double-wall fittings shall be made with listed adapter fittings designed for such purpose.

G2428.3.16–(504.3.20) Chimney and vent location. Tables G2428.3(1), G2428.3(2), G2428.3(3) and G2428.3(4) shall be used only for chimneys and vents not exposed to the outdoors below the roof line. A Type B vent or *listed* chimney lining system passing through an unused masonry chimney flue shall not be considered to be exposed to the outdoors. Where vents extend outdoors above the roof more than 5 feet (1524 mm) higher than required by Figure G2427.6.4 and where vents terminate in accordance with Section G2427.6.4, Item 2, the outdoor portion of the vent shall be enclosed as required by this section for vents not considered to be exposed to the outdoors or such venting system shall be an approved design-engineered. A Type B vent shall not be considered to be exposed to the outdoors where it passes through an unventilated enclosure or chase insulated to a value of not less than R-8.

G2428.3.17–(504.3.21) Connector maximum and minimum size. *Vent connectors* shall not be increased in size more than two sizes greater than the listed *appliance* categorized vent diameter, *flue collar* diameter or *draft hood* outlet diameter. *Vent connectors* for drafthood-equipped *appliances* shall not be smaller than the *draft hood* outlet diameter. Where a *vent connector* size(s) determined from the tables for a fan-assisted *appliance(s)* is smaller than the *flue collar* diameter, the use of the smaller size(s) shall be permitted provided that the installation complies with all of the following conditions:

1. *Vent connectors* for fan-assisted *appliance flue collars* 12 inches (305 mm) in diameter or smaller are not reduced by more than one table size [for example, 12 inches to 10 inches (305 mm to 254 mm) is a one-size reduction] and those larger than 12 inches (305 mm) in diameter are not reduced more than two table sizes [for example, 24 inches to 20 inches (610 mm to 508 mm) is a two-size reduction].
2. The fan-assisted *appliance(s)* is common vented with a draft hood-equipped *appliance(s)*.

3. The vent *connector* has a smooth interior wall.

G2428.3.18 (504.3.22)—Component commingling. Combinations of pipe sizes and combinations of single-wall and double-wall metal pipe shall be allowed within any connector run(s) or within the common vent, provided that all of the appropriate tables permit all of the desired sizes and types of pipe, as if they were used for the entire length of the subject connector or vent. Where single-wall and Type B double-wall metal pipes are used for *vent connectors* within the same venting system, the common vent must be sized using Table G2428.3(2) or G2428.3(4), as appropriate.

G2428.3.19–(504.3.23) Draft hood conversion accessories. *Draft hood* conversion accessories for use with *masonry chimneys* venting listed Category I fan-assisted *appliances* shall be listed and installed in accordance with the manufacturer's instructions for such listed accessories.

G2428.3.20 (504.3.24)–Multiple sizes permitted. Where a table permits more than one diameter of pipe to be used for a connector or vent, all of the permitted sizes shall be permitted to be used.

G2428.3.21 (504.3.25) Table interpolation. Interpolation shall be permitted in calculating capacities for vent dimensions that fall between table entries.

G2428.3.22 (504.3.26) Extrapolation prohibited. Extrapolation beyond the table entries shall not be permitted.

G2428.3.23 (504.3.27) Engineering-Design calculations. For *vent* heights less than 6 feet (1829 mm) and greater than shown in the tables, engineering-an approved design methods shall be used to calculate *vent* capacities.

G2428.3.24 (504.3.28) Height entries. Where the actual height of a vent falls between entries in the height column of the applicable table in Tables G2428.3(1) through G2428.3(4), either interpolation shall be used or the lower appliance input rating shown in the table shall be used for FAN Max and NAT Max column values and the higher appliance input rating shall be used for the FAN Min column values.

**SECTION G2429–(505)
DIRECT-VENT, INTEGRAL VENT,
MECHANICAL VENT AND VENTILATION/EXHAUST
HOOD VENTING**

G2429.1 (505.1)–General. The installation of direct-vent and integral vent *appliances* shall be in accordance with Section G2427. Mechanical *venting systems* shall be designed and installed in accordance with Section G2427.

SECTION G2430 ~~(506)~~ FACTORY-BUILT CHIMNEYS

G2430.1 ~~(506.1)~~–Listing. Factory-built *chimneys* for building heating *appliances* producing *flue gases* having a temperature not greater than 1,000°F (538°C), measured at the entrance to the *chimney*, shall be listed and *labeled* in accordance with UL 103 and shall be installed and terminated in accordance with the manufacturer’s instructions.

G2430.2 ~~(506.2)~~–Support. Where factory-built *chimneys* are supported by structural members, such as joists and rafters, such members shall be designed to support the additional load.

SECTION G2431 ~~(604)~~ GENERAL

G2431.1 ~~(601.1)~~–Scope. Sections G2432 through G2453 shall govern the approval, design, installation, construction, ~~maintenance~~, *alteration* and repair of the *appliances* and *equipment* specifically identified herein.

SECTION G2432 ~~(602)~~ DECORATIVE APPLIANCES FOR INSTALLATION IN FIREPLACES

G2432.1 ~~(602.1)~~–General. Decorative *appliances* for installation in *approved* solid fuel-burning *fireplaces* shall be *listed* in accordance with ANSI Z21.60/CSA 6.26 and shall be installed in accordance with the manufacturer’s instructions. Manually lighted natural gas decorative *appliances* shall be *listed* in accordance with ANSI Z21.84.

G2432.2 ~~(602.2)~~–Flame safeguard device. Decorative *appliances* for installation in *approved* solid fuel-burning *fireplaces*, with the exception of those *listed* in accordance with ANSI Z21.84, shall utilize a direct ignition device, an ignitor or a *pilot* flame to ignite the fuel at the *main burner*, and shall be equipped with a *flame safeguard* device. The *flame safeguard* device shall automatically shut off the fuel supply to a *main burner* or group of *burners* when the means of ignition of such *burners* becomes inoperative.

G2432.3 ~~(602.3)~~–Prohibited installations. Decorative *appliances* for installation in *fireplaces* shall not be installed where prohibited by Section G2406.2.

SECTION G2433 ~~(603)~~ LOG LIGHTERS

G2433.1 ~~(603.1)~~–General. Log lighters shall be ~~*listed* in accordance with CSA 8 and shall be~~ installed in accordance with the manufacturer’s instructions.

SECTION G2434 ~~(604)~~ VENTED GAS FIREPLACES (DECORATIVE APPLIANCES)

G2434.1 ~~(604.1)~~–General. Vented gas *fireplaces* shall be *listed* in accordance with ANSI Z21.50/CSA 2.22, shall be installed in accordance with the manufacturer’s instructions and shall be designed and equipped as specified in Section G2432.2.

G2434.2 ~~(604.2)~~–Access. Panels, grilles and access doors that are required to be removed for normal servicing operations shall not be attached to the building.

SECTION G2435 ~~(605)~~ VENTED GAS FIREPLACE HEATERS

G2435.1 ~~(605.1)~~–General. Vented gas *fireplace* heaters shall be installed in accordance with the manufacturer’s instructions, shall be *listed* in accordance with Z21.88/CSA 2.33 and shall be designed and equipped as specified in Section G2432.2.

SECTION G2436 ~~(608)~~ VENTED WALL FURNACES

G2436.1 ~~(608.1)~~–General. Vented *wall furnaces* shall be *listed* in accordance with ANSI Z21.86/CSA 2.32 and shall be installed in accordance with the manufacturer’s instructions.

G2436.2 ~~(608.2)~~–Venting. Vented *wall furnaces* shall be vented in accordance with Section G2427.

G2436.3 ~~(608.3)~~–Location. Vented *wall furnaces* shall be located so as not to cause a fire hazard to walls, floors, combustible furnishings or doors. Vented *wall furnaces* installed between bathrooms and adjoining rooms shall not circulate air from bathrooms to other parts of the building.

G2436.4 ~~(608.4)~~–Door swing. Vented *wall furnaces* shall be located so that a door cannot swing within 12 inches (305 mm) of an air inlet or air outlet of such *furnace* measured at right angles to the opening. Doorstops or door closers shall not be installed to obtain this *clearance*.

G2436.5 ~~(608.5)~~–Ducts prohibited. Ducts shall not be attached to *wall furnaces*. Casing extension boots shall not be installed unless listed as part of the *appliance*.

G2436.6 ~~(608.6)~~–Access. Vented *wall furnaces* shall be provided with *access* for cleaning of heating surfaces, removal of *burners*, replacement of sections, motors, *controls*, filters and other working parts, and for adjustments and lubrication of parts requiring such attention. Panels, grilles and access doors that are required to be removed for normal servicing operations shall not be attached to the building construction.

SECTION G2437 ~~(609)~~ FLOOR FURNACES

G2437.1 ~~(609.1)~~–General. *Floor furnaces* shall be *listed* in accordance with ANSI Z21.86/CSA 2.32 and shall be installed in accordance with the manufacturer’s instructions.

G2437.2 ~~(609.2)~~–Placement. The following provisions apply to *floor furnaces*:

1. Floors. *Floor furnaces* shall not be installed in the floor of any doorway, stairway landing, aisle or passageway of any enclosure, public or private, or in an exitway from any such room or space.
2. Walls and corners. The register of a *floor furnace* with a horizontal warm air outlet shall not be placed closer than 6 inches (152 mm) to the nearest wall. A distance of not less than 18 inches (457 mm) from two adjoining sides of the *floor furnace* register to walls shall be provided to eliminate the necessity of occupants walking over the warm-air discharge. The remaining sides shall be permitted to be placed not closer than 6 inches (152 mm) to a wall. Wall-register models shall not be placed closer than 6 inches (152 mm) to a corner.
3. Draperies. The *furnace* shall be placed so that a door, drapery, or similar object cannot be nearer than 12 inches (305 mm) to any portion of the register of the *furnace*.
4. Floor construction. *Floor furnaces* shall not be installed in concrete floor construction built on grade.
5. *Thermostat*. The controlling *thermostat* for a *floor furnace* shall be located within the same room or space as the *floor furnace* or shall be located in an adjacent room or space that is permanently open to the room or space containing the *floor furnace*.

G2437.3 ~~(609.3)~~–Bracing. The floor around the *furnace* shall be braced and headed with a support framework designed in accordance with Chapter 5.

G2437.4 ~~(609.4)~~–Clearance. The lowest portion of the *floor furnace* shall have not less than a 6-inch (152 mm) *clearance* from the grade level; except where the lower 6-inch (152 mm) portion of the *floor furnace* is sealed by the manufacturer to prevent entrance of water, the minimum *clearance* shall be not less than 2 inches (51 mm). Where such *clearances* cannot be provided, the ground below and to the sides shall be excavated to form a pit under the *furnace* so that the required *clearance* is provided beneath the lowest portion of the *furnace*. A 12-inch (305 mm) minimum *clearance* shall be provided on all sides except the *control* side, which shall have an 18-inch (457 mm) minimum *clearance*.

G2437.5 ~~(609.5)~~–First -floor installation. Where the basement story level below the floor in which a *floor furnace* is installed is utilized as habitable space, such *floor furnaces* shall be enclosed as specified in Section G2437.6 and shall project into a nonhabitable space.

G2437.6 ~~(609.6)~~–Upper -floor installations. *Floor furnaces* installed in upper stories of buildings shall project below into nonhabitable space and shall be separated from the nonhabitable space by an enclosure constructed of *noncombustible materials*. The *floor furnace* shall be provided with *access, clearance* to all sides and bottom of not less than 6 inches (152 mm) and *combustion air* in accordance with Section G2407.

SECTION G2438 ~~(613)~~ CLOTHES DRYERS

G2438.1 ~~(613.1)~~–General. ~~Clothes dryers shall be listed in accordance with ANSI Z21.5.1/CSA 7.1 and shall be installed in accordance with the manufacturer’s instructions.~~ Clothes dryers shall comply with Section M1502.

SECTION G2439 ~~(614)~~ RESERVED CLOTHES DRYER EXHAUST

~~**G2439.1 ~~(614.1)~~–Installation.** *Clothes dryers* shall be exhausted in accordance with the manufacturer’s instructions. Dryer exhaust systems shall be independent of all other systems and shall convey the moisture and any products of *combustion* to the outside of the building.~~

~~**G2439.2 ~~(614.2)~~–Duct penetrations.** Ducts that exhaust *clothes dryers* shall not penetrate or be located within any fireblocking, draftstopping or any wall, floor/ceiling or other assembly required by this *code* to be fire resistance rated, unless such duct is constructed of galvanized steel or aluminum of the thickness specified in the mechanical provisions of this *code* and the fire resistance rating is maintained in accordance with this *code*. Fire dampers shall not be installed in *clothes dryer* exhaust duct systems.~~

~~**G2439.3 ~~(614.4)~~–Exhaust installation.** Exhaust ducts for *clothes dryers* shall terminate on the outside of the building and shall be equipped with a backdraft *damper*. Screens shall not be installed at the duct termination. Ducts shall not be connected or installed with sheet metal screws or other fasteners that will obstruct the flow. *Clothes dryer* exhaust ducts shall not be connected to a *vent connector, vent* or *chimney*. *Clothes dryer* exhaust ducts shall not extend into or through ducts or plenums. *Clothes dryer* exhaust ducts shall be sealed in accordance with Section M1601.4.1.~~

~~**G2439.3.1 ~~(614.4.1)~~–Exhaust termination outlet and passageway.** The passageway of dryer exhaust duct terminals shall be undiminished in size and shall provide an open area of not less than 12.5 square inches (8065 mm²).~~

~~**G2439.4 ~~(614.5)~~–Dryer exhaust duct power ventilators.** Domestic dryer exhaust duct power ventilators shall be *listed* and *labeled* to UL 705 for use in dryer exhaust duct systems. The dryer exhaust duct power ventilator shall be installed in accordance with the manufacturer’s instructions.~~

~~**G2439.5 ~~(614.7)~~–Makeup air.** Installations exhausting more than~~

200 cfm (0.09 m³/s) shall be provided with *makeup air*.

~~G2439.5.1 (614.7.1) Closet installation.~~ Where a closet is designed for the installation of a *clothes dryer*, an opening having an area of not less than 100 square inches (645 mm²) for *makeup air* shall be provided in the closet enclosure, or *makeup air* shall be provided by other *approved means*.

~~G2439.6 (614.8) Protection required.~~ Protective shield plates shall be placed where nails or screws from finish or other work are likely to penetrate the *clothes dryer* exhaust duct. Shield plates shall be placed on the finished face of all framing members where there is less than 1¹/₄ inches (32 mm) between the duct and the finished face of the framing member. Protective shield plates shall be constructed of steel, shall have a minimum thickness of 0.062 inch (1.6 mm) and shall extend not less than 2 inches (51 mm) above sole plates and below top plates.

~~G2439.7 (614.9) Domestic clothes dryer exhaust ducts.~~ Exhaust ducts for domestic *clothes dryers* shall conform to the requirements of Sections G2439.7.1 through G2439.7.6.

~~G2439.7.1 (614.9.1) Material and size.~~ Exhaust ducts shall have a smooth interior finish and shall be constructed of metal not less than 0.016 inch (0.4 mm) in thickness. The exhaust duct size shall be 4 inches (102 mm) nominal in diameter.

~~G2439.7.2 (614.9.2) Duct installation.~~ Exhaust ducts shall be supported at 4 foot (1219 mm) intervals and secured in place. The insert end of the duct shall extend into the adjoining duct or fitting in the direction of airflow. Ducts shall not be joined with screws or similar fasteners that protrude more than ¹/₈ inch (3.2 mm) into the inside of the duct. Where dryer exhaust ducts are enclosed in wall or ceiling cavities, such cavities shall allow the installation of the duct without deformation.

~~G2439.7.3 (614.9.3) Transition ducts.~~ Transition ducts used to connect the dryer to the exhaust duct system shall be a single length that is *listed and labeled* in accordance with UL 2158A. Transition ducts shall be not more than 8 feet (2438 mm) in length and shall not be concealed within construction.

~~G2439.7.4 (614.9.4) Duct length.~~ The maximum allowable exhaust duct length shall be determined by one of the methods specified in Sections G2439.7.4.1 through G2439.7.4.3.

~~G2439.7.4.1 (614.9.4.1) Specified length.~~ The maximum length of the exhaust duct shall be 35 feet (10 668 mm) from the connection to the transition duct from the dryer to the outlet terminal. Where fittings are used, the maximum length of the exhaust duct shall be reduced in accordance with Table G2439.7.4.1.

TABLE G2439.7.4.1 (TABLE 614.9.4.1)
DRYER EXHAUST DUCT FITTING EQUIVALENT LENGTH

~~G2439.7.4.2 (614.9.4.2) Manufacturer's instructions.~~ The maximum length of the exhaust duct shall be determined by the dryer manufacturer's installation instructions. The *code official* shall be provided with a copy of the installation instructions for the make and model of the dryer. Where the

exhaust duct is to be concealed, the installation instructions shall be provided to the *code official* prior to the concealment inspection. In the absence of fitting equivalent length calculations from the clothes dryer manufacturer, Table G2439.7.4.1 shall be utilized.

~~G2439.7.4.3 (614.9.4.3) Dryer exhaust duct power ventilator length.~~ The maximum length of the exhaust duct shall be determined by the dryer exhaust duct power ventilator manufacturer's installation instructions.

~~G2439.7.5 (614.9.5) Length identification.~~ Where the exhaust duct equivalent length exceeds 35 feet (10 668 mm), the equivalent length of the exhaust duct shall be identified on a permanent label or tag. The label or tag shall be located within 6 feet (1829 mm) of the exhaust duct connection

~~G2439.7.6 (614.9.6) Exhaust duct required.~~ Where space for a *clothes dryer* is provided, an exhaust duct system shall be installed. Where the *clothes dryer* is not installed at the time of occupancy, the exhaust duct shall be capped at the location of the future dryer.

~~Exception:~~ Where a *listed* condensing *clothes dryer* is installed prior to occupancy of the structure.

**SECTION G2439
ENGINE AND GAS TURBINE-POWERED EQUIPMENT**

G2439.1 Powered equipment. Permanently installed equipment powered by internal combustion engines and turbines shall be installed in accordance with the manufacturer's installation instructions and in accordance with NFPA 37.

**SECTION G2440 (615)
SAUNA HEATERS**

G2440.1 (615.1) General. Sauna heaters shall be installed in accordance with the manufacturer's instructions, [this section and Section M1902](#).

~~G2440.2 (615.2) Location and protection.~~ Sauna heaters shall be located so as to minimize the possibility of accidental contact by a person in the room.

~~G2440.2.1 (615.2.1) Guards.~~ Sauna heaters shall be protected from accidental contact by an *approved guard or barrier* of material having a low coefficient of thermal conductivity. The guard shall not substantially affect the transfer of heat from the heater to the room.

~~G2440.3 (615.3) Access.~~ Panels, grilles and *access doors* that are required to be removed for normal servicing operations, shall not be attached to the building.

~~G2440.2 G2440.4 (615.4) Combustion and dilution air intakes.~~ Sauna heaters of other than the direct-vent type shall be installed with the *draft hood* and *combustion air* intake located outside the sauna room. Where the *combustion air* inlet and the *draft hood* are in a dressing room adjacent to the sauna room, there shall be

provisions to prevent physically blocking the *combustion air* inlet and the *draft hood* inlet, and to prevent physical contact with the *draft hood* and vent assembly, or warning notices shall be posted to avoid such contact. Any warning notice shall be easily readable, shall contrast with its background and the wording shall be in letters not less than $\frac{1}{4}$ inch (6.4 mm) high.

G2440.3 ~~G2440.5 (615.5)~~ Combustion and ventilation air. *Combustion air* shall not be taken from inside the sauna room. *Combustion* and ventilation air for a sauna heater not of the direct-vent type shall be provided to the area in which the *combustion air* inlet and *draft hood* are located in accordance with Section G2407.

~~**G2440.6 (615.6) Heat and time controls.** Sauna heaters shall be equipped with a *thermostat* that will limit room temperature to 194°F (90°C). If the *thermostat* is not an integral part of the sauna heater, the heat sensing element shall be located within 6 inches (152 mm) of the ceiling. If the heat sensing element is a capillary tube and bulb, the assembly shall be attached to the wall or other support, and shall be protected against physical damage.~~

~~**G2440.6.1 (615.6.1) Timers.** A timer, if provided to control main burner operation, shall have a maximum operating time of 1 hour. The control for the timer shall be located outside the sauna room.~~

~~**G2440.7 (615.7) Sauna room.** A ventilation opening into the sauna room shall be provided. The opening shall be not less than 4 inches by 8 inches (102 mm by 203 mm) located near the top of the door into the sauna room.~~

SECTION G2441 ~~(617)~~ POOL AND SPA HEATERS

G2441.1 ~~(617.1)~~ General. Pool and spa heaters shall be *listed* in accordance with ANSI Z21.56/CSA 4.7 and shall be installed in accordance with the manufacturer's instructions.

SECTION G2442 ~~(618)~~ FORCED-AIR WARM-AIR FURNACES

G2442.1 ~~(618.1)~~ General. Forced-air warm-air *furnaces* shall be *listed* in accordance with ANSI Z21.47/CSA 2.3 or UL 795 and shall be installed in accordance with the manufacturer's instructions.

G2442.2 Forced-air furnaces. The minimum unobstructed total area of the outside and return air ducts or openings to a forced-air warm-air furnace shall be not less than 2 square inches for each 1,000 Btu/h (4402 mm²/W) output rating capacity of the furnace and not less than that specified in the furnace manufacturer's installation instructions. The minimum unobstructed total area of supply ducts from a forced-air warm-air furnace shall be not less than 2 square inches for each 1,000 Btu/h (4402 mm²/W) output rating capacity of the furnace and not less than that specified in the furnace manufacturer's installation instructions.

Exception: The total area of the supply air ducts and outside and return air ducts shall not be required to be larger than the minimum size required by the furnace manufacturer's installation instructions.

G2442.3 ~~G2442.2 (618.2)~~ Dampers. Volume dampers shall not be placed in the air inlet to a *furnace* in a manner that will reduce the required air to the *furnace*.

G2442.4 ~~G2442.3 (618.3)~~ Prohibited sources. Outdoor or return air for forced-air heating and cooling systems shall not be taken from the following locations:

1. Closer than 10 feet (3048 mm) from an *appliance* vent outlet, a vent opening from a plumbing drainage system or the discharge outlet of an exhaust fan, unless the outlet is 3 feet (914 mm) above the outside air inlet.
2. Where there is the presence of objectionable odors, fumes or flammable vapors; or where located less than 10 feet (3048 mm) above the surface of any abutting public way or driveway; or where located at grade level by a sidewalk, street, alley or driveway.
3. A hazardous or insanitary location or a refrigeration machinery room as defined in the *International Mechanical Code*.
4. A room or space, the volume of which is less than 25 percent of the entire volume served by such system. Where connected by a permanent opening having an area sized in accordance with this code, adjoining rooms or spaces shall be considered to be a single room or space for the purpose of determining the volume of such rooms or spaces.

Exception: The minimum volume requirement shall not apply where the amount of return air taken from a room or space is less than or equal to the amount of supply air delivered to such room or space.

5. A room or space containing an *appliance* where such a room or space serves as the sole source of return air.

Exceptions: This shall not apply where:

1. The *appliance* is a direct-vent *appliance* or an *appliance* not requiring a vent in accordance with Section G2425.8.
2. The room or space complies with the following requirements:
 - 2.1. The return air shall be taken from a room or space having a volume exceeding 1 cubic foot for each 10 Btu/h (9.6 L/W) of combined input rating of all fuel-burning appliances therein.
 - 2.2. The volume of supply air discharged back into the same space shall be approximately equal to the volume of return air taken from the space.
 - 2.3. Return-air inlets shall not be located within 10 feet (3048 mm) of a draft hood in the same room or space or the combustion chamber of any

atmospheric burner *appliance* in the same room or space.

3. Rooms or spaces containing solid fuel-burning appliances, provided that return-air inlets are located not less than 10 feet (3048 mm) from the firebox of such appliances.
6. A closet, bathroom, toilet room, kitchen, garage, boiler room, furnace room or unconditioned attic.

Exceptions:

1. Where return air intakes are located not less than 10 feet (3048 mm) from cooking appliances and serve only the kitchen area, taking return air from a kitchen area shall not be prohibited.
2. Dedicated forced -air systems serving only a garage shall not be prohibited from obtaining return air from the garage.
7. A crawl space by means of direct connection to the return side of a forced-air system. ~~Transfer openings in the crawl space enclosure shall not be prohibited.~~

G2442.5 ~~G2442.4 (618.4)~~ **Screen.** Required outdoor air inlets shall be covered with a screen having 1/4-inch (6.4 mm) openings.

G2442.6 ~~G2442.5 (618.5)~~ **Return-air limitation.** Return air from one *dwelling unit* shall not be discharged into another *dwelling unit*.

G2442.7 ~~G2442.6 (618.6)~~ **Furnace plenums and air ducts.** Where a *furnace* is installed so that supply ducts carry air circulated by the *furnace* to areas outside of the space containing the *furnace*, the return air shall be handled by a duct(s) sealed to the *furnace* casing and terminating outside of the space containing the *furnace*.

SECTION G2443 (619)
CONVERSION BURNERS

G2443.1 ~~(619.1)~~ **Conversion burners.** The installation of *conversion burners* shall conform to ANSI Z21.8.

SECTION G2444 (620)
UNIT HEATERS

G2444.1 ~~(620.1)~~ **General.** *Unit heaters* shall be *listed* in accordance with ANSI Z83.8/CSA 2.6 and shall be installed in accordance with the manufacturer's instructions.

G2444.2 ~~(620.2)~~ **Support.** Suspended-type *unit heaters* shall be supported by elements that are designed and constructed to accommodate the weight and dynamic loads. Hangers and brackets shall be of noncombustible material.

G2444.3 ~~(620.3)~~ **Ductwork.** Ducts shall not be connected to a unit heater unless the heater is *listed* for such installation.

G2444.4 ~~(620.4)~~ **Clearance.** Suspended-type *unit heaters* shall be installed with *clearances* to *combustible materials* of not less than 18 inches (457 mm) at the sides, 12 inches (305 mm) at the bottom and 6 inches (152 mm) above the top where the unit heater has an internal *draft hood* or 1 inch (25 mm) above the top of the sloping side of the vertical *draft hood*.

Floor-mounted-type *unit heaters* shall be installed with *clearances* to *combustible materials* at the back and one side only of not less than 6 inches (152 mm). Where the *flue gases* are vented horizontally, the 6-inch (152 mm) *clearance* shall be measured from the *draft hood* or *vent* instead of the rear wall of the unit heater. Floor-mounted-type *unit heaters* shall not be installed on combustible floors unless *listed* for such installation.

Clearances for servicing all *unit heaters* shall be in accordance with the manufacturer's installation instructions.

Exception: *Unit heaters listed* for reduced *clearance* shall be permitted to be installed with such *clearances* in accordance with their listing and the manufacturer's instructions.

SECTION G2445 (621)
UNVENTED ROOM HEATERS

G2445.1 ~~(621.1)~~ **General.** *Unvented room heaters* shall be *listed* in accordance with ANSI Z21.11.2 and shall be installed in accordance with the conditions of the listing and the manufacturer's instructions.

G2445.2 ~~(621.2)~~ **Prohibited use.** One or more *unvented room heaters* shall not be used as the sole source of comfort heating in a *dwelling unit*.

G2445.3 ~~(621.3)~~ **Input rating.** *Unvented room heaters* shall not have an input rating in excess of 40,000 *Btu/h* (11.7 kW).

G2445.4 ~~(621.4)~~ **Prohibited locations.** The location of *unvented room heaters* shall comply with Section G2406.2.

G2445.5 ~~(621.5)~~ **Room or space volume.** The aggregate input rating of all *unvented appliances* installed in a room or space shall not exceed 20 *Btu/h* per *cubic foot* (207 W/m³) of volume of such room or space. Where the room or space in which the *appliances* are installed is directly connected to another room or space by a doorway, archway or other opening of comparable size that cannot be closed, the volume of such adjacent room or space shall be permitted to be included in the calculations.

G2445.6 ~~(621.6)~~ **Oxygen-depletion safety system.** *Unvented room heaters* shall be equipped with an oxygen-depletion-sensitive safety shutoff system. The system shall shut off the gas supply to the main and *pilot burners* when the oxygen in the surrounding atmosphere is depleted to the percent concentration specified by the manufacturer, but not lower than 18 percent. The system shall not incorporate field adjustment means capable of changing the set point at which the system acts to shut off the gas supply to the room heater.

G2445.7—(621.7) Unvented decorative room heaters. An unvented decorative room heater shall not be installed in a *factory-built fireplace* unless the *fireplace* system has been specifically tested, *listed* and *labeled* for such use in accordance with UL 127.

G2445.7.1—(621.7.1) Ventless firebox enclosures. Ventless firebox enclosures used with unvented decorative room heaters shall be *listed* as complying with ANSI Z21.91.

SECTION G2446 ~~(622)~~ VENTED ROOM HEATERS

G2446.1 ~~(622.1)~~ General. *Vented room heaters* shall be *listed* in accordance with ANSI Z21.86/CSA 2.32, shall be designed and equipped as specified in Section G2432.2 and shall be installed in accordance with the manufacturer's instructions.

SECTION G2447 ~~(623)~~ COOKING APPLIANCES

G2447.1 ~~(623.1)~~ Cooking appliances. Cooking *appliances* that are designed for permanent installation, including ranges, ovens, stoves, broilers, grills, fryers, griddles, hot plates and barbecues, shall be *listed* in accordance with ANSI Z21.1 or ANSI Z21.58/CSA 1.6 and shall be installed in accordance with the manufacturer's instructions.

G2447.2—(623.2) Prohibited location. Cooking appliances designed, tested, *listed* and *labeled* for use in commercial occupancies shall not be installed within dwelling units or within any area where domestic cooking operations occur.

Exception: Appliances that are also listed as domestic cooking appliances.

G2447.3—(623.3) Domestic appliances. Cooking *appliances* installed within *dwelling units* and within areas where domestic cooking operations occur shall be *listed* and *labeled* as household-type *appliances* for domestic use.

G2447.4—(623.4) Range installation. Ranges installed on combustible floors shall be set on their own bases or legs and shall be installed with *clearances* of not less than that shown on the label.

G2447.5—(623.7) Vertical clearance above cooking top. Household cooking *appliances* shall have a vertical *clearance* above the cooking top of not less than 30 inches (760 mm) to *combustible material* and metal cabinets. A minimum *clearance* of 24 inches (610 mm) is permitted where one of the following is installed:

1. The underside of the *combustible material* or metal cabinet above the cooking top is protected with not less than 1/4-inch (6.4 mm) insulating millboard covered with sheet metal not less than 0.0122 inch (0.3 mm) thick.

2. A metal ventilating hood constructed of sheet metal not less than 0.0122 inch (0.3 mm) thick is installed above the cooking top with a *clearance* of not less than 1/4 inch (6.4 mm) between the hood and the underside of the *combustible material* or metal cabinet. The hood shall have a width not less than the width of the *appliance* and shall be centered over the *appliance*.

3. A *listed* cooking *appliance* or microwave oven is installed over a *listed* cooking *appliance* and in compliance with the terms of the manufacturer's installation instructions for the upper *appliance*.

SECTION G2448 ~~(624)~~ WATER HEATERS

G2448.1 ~~(624.1)~~ General. Water heaters shall be *listed* in accordance with ANSI Z21.10.1/CSA 4.1 or ANSI Z21.10.3/CSA 4.3 and shall be installed in accordance with the manufacturer's instructions and the *Plumbing Code*.

G2448.1.1 ~~(624.1.1)~~ Installation requirements. The requirements for *water heaters* relative to sizing, *relief valves*, drain pans and scald protection shall be in accordance with ~~this~~ the *Plumbing Code*.

G2448.2—(624.2) Water heaters utilized for space heating. *Water heaters* utilized both to supply potable hot water and provide hot water for space-heating applications shall be *listed* and *labeled* for such applications by the manufacturer and shall be installed in accordance with the manufacturer's instructions, Section M2005 and ~~this~~ the *Plumbing Code*.

SECTION G2449 ~~(627)~~ AIR-CONDITIONING APPLIANCES

G2449.1 ~~(627.1)~~ General. Gas-fired air-conditioning *appliances* shall be *listed* in accordance with ANSI Z21.40.1/CSA 2.91 or ANSI Z21.40.2/CSA 2.92 and shall be installed in accordance with the manufacturer's instructions.

G2449.2—(627.2) Independent piping. *Gas piping* serving heating *appliances* shall be permitted to also serve cooling *appliances* where such heating and cooling *appliances* cannot be operated simultaneously (see Section G2413).

G2449.3 ~~(627.3)~~ Connection of gas -engine-powered air conditioners. To protect against the effects of normal vibration in service, gas engines shall not be rigidly connected to the gas supply *piping*.

G2449.4 ~~(627.6)~~ Installation. Air -conditioning *appliances* shall be installed in accordance with the manufacturer's instructions. Unless the *appliance* is *listed* for installation on a combustible surface such as a floor or roof, or unless the surface is protected in an *approved* manner, the *appliance* shall be installed on a surface of noncombustible construction with *noncombustible material* and surface finish, and *combustible material* shall not be against the underside thereof.

SECTION G2450 ~~(628)~~ ILLUMINATING APPLIANCES

G2450.1 ~~(628.1)~~ General. Illuminating *appliances* shall be *listed* in accordance with ANSI Z21.42 and shall be installed in accordance with the manufacturer's instructions.

G2450.2 ~~(628.2)~~ Mounting on buildings. Illuminating *appliances* designed for wall or ceiling mounting shall be securely attached to substantial structures in such a manner that they are not dependent on the *gas piping* for support.

G2450.3 ~~(628.3)~~ Mounting on posts. Illuminating *appliances* designed for post mounting shall be securely and rigidly attached to a post. Posts shall be rigidly mounted. The strength and rigidity of posts greater than 3 feet (914 mm) in height shall be at least equivalent to that of a 2½-inch-diameter (64 mm) post constructed of 0.064-inch-thick (1.6 mm) steel or a 1-inch (25 mm) Schedule 40 steel *pipe*. Posts 3 feet (914 mm) or less in height shall not be smaller than a ¾-inch (19.1 mm) Schedule 40 steel *pipe*. Drain openings shall be provided near the base of posts where there is a possibility of water collecting inside them.

G2450.4 ~~(628.4)~~ Appliance pressure regulators. Where an *appliance pressure regulator* is not supplied with an illuminating *appliance* and the service line is not equipped with a *service pressure regulator*, an *appliance pressure regulator* shall be installed in the line to the illuminating *appliance*. For multiple installations, one *regulator* of adequate capacity shall be permitted to serve more than one illuminating *appliance*.

SECTION G2451 ~~(630)~~ INFRARED RADIANT HEATERS

G2451.1 ~~(630.1)~~ General. Infrared radiant heaters shall be *listed* in accordance with ANSI Z83.19 or Z83.20 and shall be installed in accordance with the manufacturer's instructions.

G2451.2 ~~(630.2)~~ Support. *Infrared radiant heaters* shall be fixed in a position independent of gas and electric supply lines. Hangers and brackets shall be of *noncombustible material*.

SECTION G2452 ~~(634)~~ RESERVED

BOILERS

G2452.1 ~~(631.1)~~ Standards. Boilers shall be *listed* in accordance with the requirements of ANSI Z21.13/CSA 4.9 or UL 795. If applicable, the boiler shall be designed and constructed in accordance with the requirements of ASME CSD 1 and as applicable, the ASME *Boiler and Pressure Vessel Code*, Sections I, II, IV, V and IX and NFPA 85.

G2452.2 ~~(631.2)~~ Installation. In addition to the requirements of this code, the installation of boilers shall be in accordance with the manufacturer's instructions. Operating instructions of a permanent type shall be attached to the boiler. Boilers shall have

~~all controls set, adjusted and tested by the installer. A complete control diagram together with complete boiler operating instructions shall be furnished by the installer. The manufacturer's rating data and the nameplate shall be attached to the boiler.~~

~~G2452.3 ~~(631.3)~~ Clearance to combustible material. Clearances to combustible materials shall be in accordance with Section G2409.4.~~

SECTION G2452 ~~G2453~~ ~~(636)~~ OUTDOOR DECORATIVE APPLIANCES

G2452.1 ~~(635.1)~~ General. Permanently fixed-in-place outdoor decorative appliances shall be *listed* in accordance with ANSI Z21.97 and shall be installed in accordance with the manufacturer's instructions.