

2023 Oregon Residential Specialty Code Adoption



Department of Consumer and Business Services

Summary of amendments to the base code

Effective: Oct. 1, 2023

The 2023 Oregon Residential Specialty Code (ORSC) became effective Oct. 1, 2023, with a 6-month phase-in period ending March 31, 2024. During the phase-in period, use of the 2021 ORSC or the 2023 ORSC is permitted.

The 2023 ORSC is based on the 2021 International Residential Code (IRC) and Oregon-specific amendments. The following is a summary of the substantive adopted amendments and model code changes to the 2021 IRC. This summary is intended to help with the transition from the previous edition and does not include all changes adopted in the 2023 ORSC.

The changes are denoted as follows:

Existing Oregon amendments

Blue/underline

Existing added language to the 2021 IRC

~~Red/strikethrough~~

Existing deleted language from the 2021 IRC

New Oregon amendments

Blue/dotted-underline

New added language to the 2021 IRC

~~Red/double-strikethrough~~

New deletions from the 2021 IRC

~~Red/double-strikethrough/underline~~

Rescinded Oregon amendments

New IRC changes

Pink

New IRC language

~~Pink/strikethrough~~

Deleted IRC language

Purple underline/strikethrough

2023 ORSC Errata

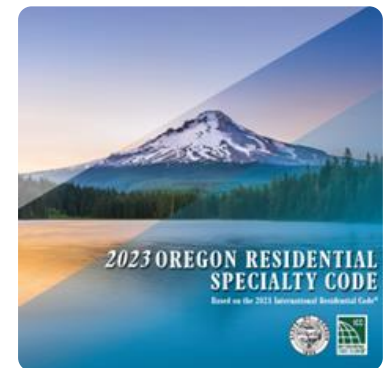

Section reference corrections and renumbered sections are not shown in this summary.

Notes for Chapter 1: The entire chapter is included in this summary. The deleted language has not been included.

Notes for Chapter 11: The entire chapter is included in this summary. The changes have been identified.

The following amendments were made throughout the 2021 IRC and are not included in this summary unless otherwise stated in this summary:

References to:

Changed to (unless otherwise indicated in this summary):

Code official.....	Building official
International Mechanical Code.....	Applicable provisions of the Oregon Mechanical Specialty Code
International Fuel Gas Code.....	Applicable provisions of the Oregon Mechanical Specialty Code
International Residential Code.....	Applicable provisions of the Oregon Residential Specialty Code
NFPA 70 and Chapters 34-43.....	Applicable provisions of the Oregon Electrical Specialty Code
International Plumbing Code or Chapters 25-33.....	Applicable provisions of the Oregon Plumbing Specialty Code
ASME Boiler and Pressure Vessel Code/ASME CSD-1.....	Applicable provisions of the Oregon Boiler and Pressure Vessel Specialty Code
Ultimate design wind speed.....	Basic design wind speed

For questions about the 2023 ORSC, visit the division website to [contact a building code specialist](#).



Part I – Administrative

CHAPTER 1 SCOPE AND ADMINISTRATION

Part I—SCOPE AND APPLICATION

SECTION R101 SCOPE AND GENERAL REQUIREMENTS

R101.1 Title. These provisions shall be known as the *Oregon Residential Specialty Code* and shall be cited as such and will be referred to herein as “this code.”

R101.2 Scope. The *Oregon Residential Specialty Code*, as adopted by the State of Oregon, Building Codes Division, includes portions of the *International Residential Code* and the *International Fire Code* pertaining to any construction, reconstruction, alteration, repair and installation of materials and equipment in or part of buildings and structures covered under the state building code.

R101.2.1 Application. The provisions of this code shall apply to the construction, alteration, movement, enlargement, replacement, repair, equipment, use, occupancy and location of the following:

1. Detached one- and two-family dwellings and townhouses classified as Group R-3, not more than three stories above grade plane in height, and their accessory structures.
2. Detached owner-occupied lodging houses containing not more than five guestrooms.
3. Residential aircraft hangars as defined in Section R202.
4. Live/work units located in detached one- and two-family dwellings and townhouses and complying with the requirements of Section 508.5 of the *Building Code*.

Exception: Dwelling units that include an office that is less than 10 percent of the area of the dwelling unit are not required to comply with the requirements of Section 508.5 of the *Building Code*.

The following uses shall comply with the *Building Code*:

1. New registered or certified family child care facilities as defined in ORS 329A, new adult foster homes as defined in ORS 443.705 and new residential training homes as defined in ORS 443.400, located within a detached one-family dwelling and classified as Group R-3 occupancies.
2. Congregate living facilities.

In accordance with ORS 455.616, dwellings 400 square feet (37.16 m²) in area or less shall comply with the *Small Home Specialty Code*.

R101.2.2 Optional local adoption to require a building permit. In addition to the work exempt from building permits in Section R105, the following items are exempt from building permits unless specifically required by a municipality's local ordinance. If a municipality adopts an ordinance to require a permit for any of these items, the construction standards of this code shall be applicable:

1. Fences, other than required swimming pool barriers, constructed of wood, wire mesh or chain link. Statewide, fences serving as a swimming pool barrier, or as a portion of a swimming pool barrier, shall require a building permit. A municipality may adopt an ordinance to regulate the construction of other fences constructed of wood, wire mesh or chain link, provided that the threshold established for requiring a building permit does not include fences that are 7 feet (2134 mm) or less in height. A municipality may adopt an ordinance to regulate fences constructed of materials other than wood, wire mesh or chain link, regardless of height. A local height threshold greater than 7 feet (2134 mm) is allowed, regardless of which materials are used.
2. Retaining walls. Statewide, retaining walls that provide safeguards for the users of the buildings, support a regulated building or retain material that, if not restrained, could impact a regulated building shall require a building permit. A municipality may adopt an ordinance to regulate other retaining walls, provided that the threshold established for requiring a permit does not include retaining walls 4 feet (1219 mm) or less in height, when measured from the bottom of the footing to the top of the wall, except where the retaining wall supports ascending slopes exceeding 3:1 or where the retaining wall supports a nonsoil surcharge. A local height threshold greater than 4 feet (1219 mm) is allowed.
3. Freestanding radio, television and other telecommunication antennae and towers not attached to or supported by a regulated building. A local municipality may adopt an ordinance to require a building permit for these structures.

4. Ground-mounted photovoltaic systems. A local municipality may adopt an ordinance requiring a building permit for these structures, provided that a permit is not required where these structures are 10 feet (3048 mm) or less in height, measured to the highest point of the installation, and no public access is permitted beneath the structures. A local height threshold greater than 10 feet (3048 mm) is allowed.
5. Tanks that are located exterior to and not attached to or supported by a regulated building.
6. Fixed docks not supporting a superstructure.
7. The design and construction of in-ground swimming pools accessory to detached one- and two-family dwellings, and individual townhouse dwelling units.

R101.2.3 Matters not available for local regulation under the statutory authority of this code. While the following matters may be included in the published national model code, they may not be regulated by the local *municipality* under the authority of this code. Any references to these matters in this code have been retained for the reader’s convenience.

R101.2.3.1 Matters outside the statutory authority of this code. The following matters are outside the statutory authority of this code. Local *municipalities* may not regulate these matters under the authority of this code. A *municipality* may have additional authority outside of this code to regulate these matters locally, where not preempted:

1. Post-occupancy lease or rental arrangements, short-term rentals, vacation rentals and similar uses.
2. Public utility facilities owned and maintained by the serving utility.
3. Abatement of nuisances and dangerous buildings.
4. Demolition.
5. Floating structures.
6. Floating docks.
7. Transitional housing accommodations.
8. Administration and implementation of a National Flood Insurance Program (NFIP).
9. Mechanical equipment not specifically regulated in this code.

R101.2.3.2 Matters preempted by the state building code. The following matters are not adopted, are preempted by the *state building code* and may not be adopted by a local *municipality*:

1. Appendix AA (Sizing and Capacities of Gas Piping).
2. Appendix AB (Sizing of Venting Systems Serving Appliances Equipped with Draft Hoods, Category I Appliances and Appliances Listed for Use with Type B Vents).
3. Appendix AC (Reserved).

4. Appendix AD (Recommended Procedure for Safety Inspection of an Existing Appliance Installation).
5. Appendix AG (Piping Standards for Various Applications).
6. Appendix AI (Private Sewage Disposal).
7. Appendix AJ (Existing Buildings and Structures).
8. Appendix AL (Permit Fees).
9. Appendix AM (Home Day Care—R-3 Occupancy).
10. Appendix AN (Venting Methods).
11. Appendix AO (Automatic Vehicular Gates).
12. Appendix AP (Sizing of Water Piping System).
13. Appendix AQ (Tiny Houses).
14. Appendix AT (Solar-ready Provisions—Detached One- and Two-family Dwellings and Townhouses).
15. Appendix AV (Board of Appeals).
16. Appendix AX (Zero Energy Residential Building Provisions)

R101.2.4 Appendices. The following appendices are adopted as part of this code:

1. Appendix AE (Manufactured Housing Used as Dwellings).
2. Appendix AF (Radon Control Methods).
3. Appendix AH (Deck, Patio or Porch Covers).
4. Appendix AK (Sound Transmission).
5. Appendix AR (Light Straw-clay Construction).
6. Appendix AS (Strawbale Construction).
7. Appendix AU [COB Construction (Monolithic Adobe)].
8. Appendix AW (3D-printed Building Construction).

R101.3 Owner-built dwellings. For owner-built dwellings and outbuildings, see ORS 455.320.

ORS 455.320 is not part of this code but is reprinted here for the reader’s convenience:

455.320 Owner-built dwellings exempt from certain structural code provisions; recording of exemption.

(1) As used in this section, unless the context requires otherwise:

(a) “Owner” means the owner of the title to real property or the contract purchaser of real property, of record as shown on the last available complete assessment roll which person has not taken advantage of the exemptions under subsection (2) of this section during the five years prior to applying for an exemption under this section.

(b) “Owner-built dwelling and outbuildings” means a single-family residence and adjacent auxiliary structures the structural components of which are constructed entirely by the owner who intends to occupy the structures or by that owner and friends and relatives of the owner assisting on an unpaid basis.

(2) Owner-built dwellings and outbuildings shall be exempt from any requirements of the structural code for ceiling heights, room sizes and the maintenance of specific temperature levels in those structures. The exemption shall apply to the new construction, renovation, remodeling or alteration of an owner-built dwelling or outbuilding.

(3) A building permit issued for an owner-built dwelling or outbuilding shall note whether the owner-built dwelling or outbuilding complies with the requirements it is exempted from under subsection (2) of this section. If the dwelling or other structure does not comply with these requirements, the owner-builder shall file a copy of the building permit with the county clerk, who shall make the permit a part of the permanent deed record of the property. The owner shall provide the county clerk with a description of the property sufficient if it were contained in a mortgage of the property to give constructive notice of the mortgage under the law of this state.

(4) Noncompliance with subsection (3) of this section shall not affect, in any manner, any conveyance of interest in property subject to this section.

R101.4 Purpose. The purpose of this code is to establish minimum requirements to provide a reasonable level of safety, health and general welfare through affordability, structural strength, means of egress, stability, sanitation, light and ventilation, energy conservation and safety to life and property from fire and other hazards attributed to the built environment, and to provide a reasonable level of safety to fire fighters and emergency responders during emergency operations.

SECTION R102 APPLICABILITY

R102.1 General. Where there is a conflict between a general requirement and a specific requirement, the specific requirement shall be applicable. Where, in any specific case, different sections of this code specify different materials, methods of construction or other requirements, the most restrictive shall govern. Consistent with discretionary decision-making powers granted to building officials, a building official may take any action including but not limited to waiving a requirement, modifying a requirement and/or accepting an alternate method to the requirements of the state building code. When waiving or accepting a modification, a building official shall not allow a provision that would create an unsafe or dangerous condition regarding fire and life safety, and may not enforce requirements that are in addition to the state building code except where additional code requirements are specified by the terms of an alternate method approval.

R102.1.1 Statutory references. This code is adopted pursuant to Oregon Revised Statutes (ORS). Where this code and the statutes specify different requirements, the statute shall govern. Statutes related to this code include, but are not limited to, ORS 455.010 through 455.895.

Statutes referenced may be obtained from the Building Codes Division, 1535 Edgewater St. NW, Salem, OR 97304 or P.O. Box 14470, Salem, OR 97309 at a nominal cost or read online at Oregon.gov/bcd/laws-rules.

R102.2 Other laws. The provisions of this code shall not be deemed to nullify any provisions of local, state or federal law.

R102.3 Application of references. References to chapter or section numbers, or to provisions not specifically identified by number, shall be construed to refer to such chapter, section or provision of this code.

R102.4 Referenced codes and standards. The codes and standards referenced in this code shall be considered part of the requirements of this code to the prescribed extent of each such reference and as further regulated in Sections R102.4.1 through R102.4.3.

Exception: Where enforcement of a code provision would violate the conditions of the *listing* of the *equipment* or *appliance*, the conditions of the *listing* and manufacturer's instructions shall apply.

R102.4.1 Conflicts. Where conflicts occur between provisions of this code and referenced codes and standards, the provisions of this code shall apply.

R102.4.2 Provisions in referenced codes and standards. Where the extent of the reference to a referenced code or standard includes subject matter that is within the scope of this code, the provisions of this code, as applicable, shall take precedence over the provisions in the referenced code or standard.

OAR 918-008-0000 is not part of this code but is reprinted here for the reader's convenience:

918-008-0000 Purpose and Scope

(1) The Department of Consumer and Business Services, Building Codes Division, adopts model building codes, standards and other publications by reference, as necessary, through administrative rule to create the state building code. When a matter is included in a specialty code or referenced publication that is in conflict with Oregon Revised Statutes or Oregon Administrative Rules, the statute or rule applies and the code or standard provision does not. All remaining parts or application of the code or standard remain in effect.

(2) Unless required by law, matters generally not authorized for inclusion in a specialty code or referenced standard include, but are not limited to: licensing or certification requirements, or other qualifications and standards for businesses or workers; structures or equipment maintenance requirements; matters covered by federal or state law; and matters that conflict with other specialty codes or publications adopted by the department.

(3) OAR 918-008-0000 to 918-008-0070 provides the process for adopting and amending the state building code that is consistent across all program areas.

(4) The state building code is derived from the most appropriate version of base model codes, which are updated periodically.

(5) The Oregon specialty code amendment process begins approximately midway into a code cycle.

(6) An appropriate advisory board approves or forwards the adoption of the Oregon specialty code and amendments to the Department for adoption.

(7) Notwithstanding sections (3) through (6) of this rule, the division may adopt supplemental code amendments as authorized by OAR 918-008-0028.

Statutory/Other Authority: ORS 447.020, 455.030 & 479.730

Statutes/Other Implemented: ORS 447.020, 455.030 & 479.730

R102.4.3 ASCE 24 Flood Resistant Design and Construction. The following ASCE 24 Tables are not adopted by the State of Oregon as the subject matter encompasses Free Board, Base Flood Elevation and Design Flood Elevation. The authority to establish the same is reserved for local government:

1. [Table 2-1, Minimum Elevation of the Top of Lowest Floor.](#)
2. [Table 4-1, Minimum Elevation of Bottom of Lowest Supporting Horizontal Structural Member of Lowest Floor.](#)
3. [Table 5-1, Minimum Elevation Below Which Flood Damage-Resistant Materials Shall Be Used.](#)
4. [Table 6-1, Minimum Elevation of Floodproofing.](#)
5. [Table 7-1, Minimum Elevation of Attendant Utilities and Equipment.](#)

National Flood Insurance Program (NFIP).

Each local community participating in the National Flood Insurance Program (NFIP) designates a local floodplain administrator who is responsible to make sure communities meet their insurance program obligations. Certain matters comprised within the NFIP program may conflict with or overlap with the state building code. Certain decisions such as sill plate height and other NFIP criteria fall under the authority and responsibility of the floodplain administrator. Once decisions under the NFIP program are made, then the appropriate requirements of this code for the construction of the building are applied.

Local communities may choose to designate their local building official as the floodplain administrator or may designate other staff. When a building official functioning in the capacity of floodplain administrator exercises authority under the NFIP, such decisions are not part of this code nor subject to the building official duties and responsibilities as adopted by the State of Oregon, Building Codes Division.

Per ORS 455.210(3)(c), local municipalities are prohibited from using building permit monies for any matter other than administration and enforcement of the state building code. Administration and implementation of a local NFIP program are not part of the state building code.

R102.5 Reserved.

R102.6 Partial invalidity. In the event any part or provision of this code is held to be illegal or void, this shall not have the effect of making void or illegal any of the other parts or provisions.

R102.7 Existing structures. The legal occupancy of any structure existing on the date of adoption of this code shall be permitted to continue without change, except as is specifically covered in this code.

R102.7.1 Additions or alterations. *Additions or alterations* to any structure shall conform to the requirements for a new structure without requiring the existing structure to comply with the requirements of this code, unless otherwise stated. *Additions or alterations* shall not cause an existing structure to become **less compliant with the provisions of this code than the existing building or structure was prior to the addition or alteration.** An existing building together with its *additions* shall comply with the height limits of this code.

An unsafe condition shall be deemed to have been created if an addition or alteration will cause the existing building or structure to become structurally unsafe or overloaded, will not

provide adequate egress in compliance with the provisions of this code or will obstruct existing egress, will create a fire hazard, will reduce required fire resistance, or will otherwise create conditions dangerous to human life. Any building plus new additions shall not exceed the height and stories specified for new buildings in Section R101.2.

Exception: Structural changes that improve the resistance of the building to seismic forces may be made without complying with the current code requirements, provided that:

1. The strength of the existing structural elements is not reduced; and
2. An unsafe condition is not created.

R102.7.2 Repairs. *Repairs* shall not make the building any less conforming with the provisions of this code than the building was before the *repair* was undertaken. *Repairs* for the purposes of building maintenance shall comply with Section R105.2.2. *Repairs* for the purposes of correcting damage shall be permitted to conform with the code edition in effect at the time of original construction, where the requirements of this section are met.

Where it becomes necessary to repair all or a portion of a legally existing building that has been damaged by, including but not limited to, fire, wind, flood, earthquake or other similar damage, and where prior to the damage the legally existing building did not contain unsafe conditions, the building may be reconstructed exactly as it existed prior to the damage. The following requirements from the currently effective code shall be included in the reconstruction, where applicable:

1. Repaired structural elements in accordance with the design criteria and loading requirements of Chapter 3, or to the maximum extent practical as *approved* by the *building official*.
2. Smoke alarms in accordance with Section R314.
3. Carbon monoxide alarms in accordance with Section R315.
4. Guards and fall protection in accordance with Section R312.
5. Hazardous glazing locations in accordance with Section R308.
6. *Emergency escape and rescue openings* in accordance with Section R310.
7. Table N1101.2, to the maximum extent practical.
8. Floodplain construction requirements, where applicable, as established by the *floodplain administrator*.

Such repairs for the purposes of correcting damage are not required to meet other current code requirements for new construction. Where unsafe conditions existed prior to the damage occurring, the building may be reconstructed in accordance with this section, provided that the unsafe conditions are corrected, as determined by the *building official*.

Part 2—Administration and Enforcement

SECTION R103 DEPARTMENT OF BUILDING SAFETY

Not adopted by the State of Oregon, Building Codes Division, as part of this code.

SECTION R104 DUTIES AND POWERS OF THE BUILDING OFFICIAL

R104.1 General. The *building official* is hereby authorized and directed to enforce the provisions of this code. The *building official* shall have the authority to render interpretations of this code and to adopt policies and procedures in order to clarify the application of its provisions. Such interpretations, policies and procedures shall be in compliance with the intent and purpose of this code. Such policies and procedures shall not have the effect of waiving safeguard requirements specifically provided for in this code, statewide alternate methods or statewide code interpretations. Nothing in this code limits a local municipality's ability to require application of its own ordinances, or to enforce its own ordinances.

R104.2 Applications and permits. The *building official* shall receive applications, review *construction documents* and issue *permits* for the erection, alteration and moving of buildings and structures, inspect the premises for which such permits have been issued and enforce compliance with the provisions of this code.

R104.3 Notices and orders. The *building official* shall issue necessary notices or orders to ensure compliance with this code.

R104.4 Inspections. The *building official* shall make the required inspections, or the *building official* shall have the authority to accept reports of inspection by *approved agencies* or individuals. Reports of such inspections shall be in writing and be certified by a responsible officer of such *approved agency* or by the responsible individual. The *building official* is authorized to engage such expert opinion as deemed necessary to report on unusual technical issues that arise.

R104.5 Identification. This section is not adopted by the State of Oregon, Building Codes Division, as part of this code.

R104.6 Right of entry. This section is not adopted by the State of Oregon, Building Codes Division, as part of this code.

R104.7 Department records. The building official shall retain official records for the periods specified regarding the retention of public records. See OAR 166-150-0020 for locations where a county has jurisdiction; OAR 166-200-0025 where a city has jurisdiction; and OAR 166 Division 300 for the cities and counties where the State of Oregon has jurisdiction.

R104.8 Liability. See ORS 30.265 for regulations relating to liability.

ORS 30.265 is not part of this code but is reprinted here for the reader's convenience:

ORS 30.265 Scope of liability of public body, officers, employees and agents; liability in nuclear incident.

(1) Subject to the limitations of ORS 30.260 to 30.300, every public body is subject to civil action for its torts and those of its officers, employees and agents acting within the scope of their employment or duties, whether arising out of a governmental or proprietary function or while operating a motor vehicle in a ridesharing arrangement authorized under ORS 276.598.

(2) The sole cause of action for a tort committed by officers, employees or agents of a public body acting within the scope of their employment or duties and eligible for representation and indemnification under ORS 30.285 or 30.287 is an action under ORS 30.260 to 30.300. The remedy provided by ORS 30.260 to 30.300 is exclusive of any other action against any such officer, employee or agent of a public body whose act or omission within the scope of the officer's, employee's or agent's employment or duties gives rise to the action. No other form of civil action is permitted.

(3) If an action under ORS 30.260 to 30.300 alleges damages in an amount equal to or less than the damages allowed under ORS 30.271, 30.272 or 30.273, the sole cause of action for a tort committed by officers, employees or agents of a public body acting within the scope of their employment or duties and eligible for representation and indemnification under ORS 30.285 or 30.287 is an action against the public body. If an action is filed against an officer, employee or agent of a public body, and the plaintiff alleges damages in an amount equal to or less than the damages allowed under ORS 30.271, 30.272 or 30.273, the court upon motion shall substitute the public body as the defendant. Substitution of the public body as the defendant does not exempt the public body from making any report required under ORS 742.400.

(4) If an action under ORS 30.260 to 30.300 alleges damages in an amount greater than the damages allowed under ORS 30.271, 30.272 or 30.273, the action may be brought and maintained against an officer, employee or agent of a public body, whether or not the public body is also named as a defendant. An action brought under this subsection is subject to the limitations on damages imposed under ORS 30.271, 30.272 or 30.273, and the total combined amount recovered in the action may not exceed those limitations for a single accident or occurrence without regard to the number or types of defendants named in the action.

(5) Every public body is immune from liability for any claim for injury to or death of any person or injury to property resulting from an act or omission of an officer, employee or agent of a public body when such officer, employee or agent is immune from liability.

(6) Every public body and its officers, employees and agents acting within the scope of their employment or duties, or while operating a motor vehicle in a ridesharing arrangement authorized under ORS 276.598, are immune from liability for:

(a) Any claim for injury to or death of any person covered by any workers' compensation law.

(b) Any claim in connection with the assessment and collection of taxes.

(c) Any claim based upon the performance of or the failure to exercise or perform a discretionary function or duty, whether or not the discretion is abused.

(d) Any claim that is limited or barred by the provisions of any other statute, including but not limited to any statute of ultimate repose.

(e) Any claim arising out of riot, civil commotion or mob action or out of any act or omission in connection with the prevention of any of the foregoing.

(f) Any claim arising out of an act done or omitted under apparent authority of a law, resolution, rule or regulation that is unconstitutional, invalid or inapplicable except to the extent that they would have been liable had the law, resolution, rule or regulation been constitutional, valid and applicable, unless such act was done or omitted in bad faith or with malice.

(7) This section applies to any action of any officer, employee or agent of the state relating to a nuclear incident, whether or not the officer, employee or agent is acting within the scope of employment, and provided the nuclear incident is covered by an insurance or indemnity agreement under 42 U.S.C. 2210.

(8) Subsection (6)(c) of this section does not apply to any discretionary act that is found to be the cause or partial cause of a nuclear incident covered by an insurance or indemnity agreement under the provisions of 42 U.S.C. 2210, including but not limited to road design and route selection.

R104.9 Approved materials and equipment. Materials, equipment and devices approved by the *building official* shall be constructed and installed in accordance with such approval.

R104.9.1 Used materials and equipment. Used materials, equipment and devices shall not be reused unless approved by the *building official*. Used or salvaged dimensional lumber shall be permitted to be used in accordance with all of the following:

1. Used or salvaged dimensional lumber shall be in generally good condition and free of any obvious areas of decay.
2. Where used or salvaged dimensional lumber is identified by a grade mark or where a certificate of inspection is provided from a lumber grading or inspection agency approved by an accreditation body that complies with DOC PS 20, structural properties for the used or salvaged lumber shall be as determined by the approved agency in accordance with the grade stamp or certificate provided.

Exception: In lieu of the grade mark or certificate described in Item 2, used or salvaged dimensional lumber not bearing a grade stamp or provided with a certificate shall be assumed to be Douglas fir-larch No. 2 grade and shall have structural properties assigned in accordance with current adopted standards.

R104.10 Modifications. Where there are practical difficulties involved in carrying out the provisions of this code, the *building official* shall have the authority to grant modifications for individual cases upon application of the owner or owner's representative, provided the *building official* shall first find that special individual reason makes the strict letter of this code impractical and the modification is in compliance with the intent and purpose of this code and that such modification does not create an unsafe or dangerous condition regarding fire and life safety, and does not require enforcement of any requirements that are in addition to the state building code except where additional code requirements are specified by the terms of an alternate method approval. The details of action granting modifications shall be recorded and entered in the *municipality's* files.

R104.10.1 Flood hazard areas. This section is not adopted by the State of Oregon, Building Codes Division, as part of this code.

R104.11 Alternative materials, design and methods of construction and equipment. The provisions of this code are not intended to prevent the installation of any material or to prohibit any design or method of construction not specifically prescribed by this code, provided that any such alternative has been approved. An alternative material, design or method of construction shall be approved where the building official finds that the proposed alternative meets all of the following:

1. The alternative material, design or method of construction is satisfactory and complies with the intent of the provisions of this code.
2. The material, method or work offered is, for the purpose intended, not less than the equivalent of that prescribed in this code as it pertains to the following:
 - 2.1. Quality.
 - 2.2. Strength.
 - 2.3. Effectiveness.
 - 2.4. Fire resistance.
 - 2.5. Durability.
 - 2.6. Safety.

Where the alternative material, design or method of construction is not approved, the *building official* shall respond in writing, stating the reasons why the alternative was not approved.

R104.11.1 Tests. Where there is insufficient evidence of compliance with the provisions of this code, or evidence that a material or method does not conform to the requirements of this code, or in order to substantiate claims for alternative materials or methods, the *building official* shall have the authority to require tests as evidence of compliance to be made at no expense to the *municipality*. Test methods shall be as specified in this code or by other recognized test standards. In the absence of recognized and accepted test methods, the *building official* shall approve the testing procedures. Tests shall be performed by an approved agency. Reports of such tests shall be retained by the *building official* for the period required for retention of public records.

SECTION R105 PERMITS

R105.1 Required. Any owner or owner's authorized agent who intends to construct, enlarge, alter, repair, move or change the occupancy of a building or structure, or to erect, install, enlarge, alter, repair, remove, convert or replace any gas or mechanical system, the installation of which is regulated by this code, or to cause any such work to be performed, shall first make application to the *building official* and obtain the required permit.

R105.1.1 New spaces. The creation of new habitable spaces, new toilet rooms or new bathrooms shall require a building permit.

R105.2 Work exempt from permit. Exemption from *permit* requirements of this code shall not be deemed to grant authorization for any work to be done in any manner in violation of the provisions of this code or any other laws. Nothing in this code limits a local municipality's ability to require application of its ordinances or to enforce its own ordinances. See Section R101 for the application and scope of this code. *Permits* shall not be required for the following:

Building:

1. Nonhabitable one-story detached accessory structures, provided that the building area does not exceed 200 square feet (18.58 m²) and does not exceed a height of 15 feet (4572 mm) measured from grade plane to the average height of the highest roof surface.

Exception: Where the structure is located on a parcel of 2.0 acres or greater in area, and the structure is located a minimum of 20 feet (6096 mm) from all property lines and regulated structures, the building area may be increased to 400 square feet (37.16 m²).

2. Concrete sidewalks, slabs, platforms, driveways and similar work.
3. Painting; papering; tiling; carpeting; cabinets; countertops; nonfire-resistance-rated interior wall, floor or ceiling covering; shelving and similar work.
4. Above-grade and on-ground swimming pools.
5. Swings, other playground equipment and similar work.

New amendments

"Deck covers" have been added to exemption no. 6 and the distance from lot line for various types of covers is specified.



6. Porch covers, deck covers and patio covers as defined in Section AH102, not more than 200 square feet (18.58 m²) in floor area and not closer than 3 feet (914 mm) to lot lines.
7. Window awnings, supported by an exterior wall, that do not project more than 54 inches (1372 mm) from the exterior wall and do not require additional support.
8. Nonbearing partitions.

Exceptions:

1. Partitions that create habitable space.
 2. Partitions required to be fire-resistance rated.
9. Replacement or repair of siding not required to be fire-resistance rated.
 10. Porches and decks where the walking surface is not more than 30 inches (762 mm) above adjacent grade measured at any point within 3 feet (914 mm) horizontally of the walking surface.

11. Masonry repair.

12. Retrofitted Insulation.

13. Gutters and downspouts.

14. Door and window replacements. Window replacements shall comply with Section R308 and Chapter 11, as applicable.

Exceptions: *Permits* are required for the following:

1. Where a structural member is changed.
2. Doors and windows required to be fire-resistance rated.

15. Reroofing, where the associated weight from the replacement or repair of roofing and sheathing does not exceed 30 percent of the required live load design capacity based on Table R301.6.

Exceptions: *Permits* for reroofing are required for the following:

1. Structures in wildfire hazard zones as provided in Section R327.
2. Townhouses.
3. Installation of building-integrated photovoltaic roof panels and other photovoltaic roof coverings.

New amendments

Membrane-covered frame structures within certain conditions that are nonhabitable have been added as exemption from permit.



16. Membrane-covered frame structures that are non-habitable, not more than 500 square feet (46.45 m²) in floor area, one story in height and not closer than 3 feet (914 mm) to a lot line.

Unless otherwise exempted, separate plumbing, electrical and mechanical permits may be required for the previously listed exempted items.

Additionally, all new construction and substantial improvements, including certain work exempt from permit under this section, shall be designed and constructed with methods, practices and materials that minimize flood damage in accordance with this code, FEMA regulations and ASCE 24 in areas determined by the floodplain administrator.

Electrical: See the *Electrical Code*.

Mechanical:

1. Portable heating, cooking or clothes drying appliances.
2. Portable ventilation appliances.
3. Portable cooling units.
4. Steam, hot- or chilled-water piping within any heating or cooling equipment regulated by this code.
5. Replacement of any minor part that does not alter

approval of *equipment* or make such *equipment* unsafe.

6. Portable evaporative coolers.
7. Self-contained refrigeration systems containing 10 pounds (4.54 kg) or less of refrigerant or that are actuated by motors of 1 horsepower (746 W) or less.
8. Portable-fuel-cell *appliances* that are not connected to a fixed piping system and are not interconnected to a power grid.

Plumbing: [See the Plumbing Code.](#)

R105.2.1 Emergency repairs. Where [mechanical equipment](#) replacements and repairs must be performed in an emergency situation, the *permit* application shall be submitted [to the building official](#) within the next 5 working business days.

[R105.2.1.1 Structural temporary repairs.](#) [For temporary \(180 days\) structural supports, structural replacement or repairs performed in an emergency on an existing structure, the building official shall be notified within 72 hours and permit application for the temporary work shall be submitted to the building official within the next 5 business days.](#)

[ORS 455.058 is not part of this code but is reprinted here for the reader's convenience:](#)

[455.058 Investigation fee for work commenced without permit; rules.](#)

[\(1\) Except as provided in subsection \(2\) of this section, the Department of Consumer and Business Services, or a municipality administering and enforcing a building inspection program, may assess an investigation fee against a person that is required to obtain a permit for work on the electrical, gas, mechanical, elevator, boiler, plumbing or other systems of a building or structure if the work is commenced before the permit required for the work is obtained. The amount of the investigation fee shall be the average or actual additional cost of ensuring that a building, structure or system is in conformance with state building code requirements that results from the person not obtaining a required permit before work for which the permit is required commences.](#)

[\(2\) This section does not apply to:](#)

[\(a\) An emergency repair required for health, safety, the prevention of property damage or the prevention of financial harm if the required building permit for the repair is obtained no later than five business days after commencement of the repair; or](#)

[\(b\) Any project for which construction, alteration, repair, maintenance or installation in a building or structure prior to obtaining a permit is expressly authorized by law.](#)

[\(3\) The department may adopt rules and establish policies and procedures for use by the department or municipalities in assessing an investigation fee under this section. \[2013 c.324 §2\]](#)

R105.2.2 Repairs. Application or notice to the *building official* is not required for ordinary repairs to structures. [Repair work shall be performed using like materials or materials permitted by this code for new construction.](#) Such repairs shall not include the cutting away of any wall, partition or portion thereof, the removal or cutting of any structural beam or load-bearing support, or the removal or change of any required means of egress, or rearrangement of parts of a structure affecting the egress requirements; nor shall ordinary repairs include *addition* to, *alteration* of, replacement or relocation of any gas, piping or mechanical work.

R105.2.3 Public service agencies. A *permit* shall not be required for the installation, *alteration* or *repair* of generation, transmission, distribution, metering or other related equipment that is under the ownership and control of public service agencies by established right.

R105.3 Application for permit. To obtain a *permit*, the applicant shall first file an application therefor in writing on a form furnished by the [municipality](#) for that purpose. Such application shall:

1. Identify and describe the work to be covered by the *permit* for which application is made.
2. Describe the land on which the proposed work is to be done by legal description, street address or similar description that will readily identify and definitely locate the proposed building or work.
3. Indicate the use and occupancy for which the proposed work is intended.
4. Be accompanied by *construction documents* and other information as required in Section R106.1.
5. State the valuation of the proposed work.
6. Be signed by the applicant or the applicant's authorized agent.
7. Give such other data and information as required by the *building official*.

R105.3.1 Action on application. The *building official* shall examine or cause to be examined applications for *permits* and amendments thereto within a reasonable time after filing. If the application or the *construction documents* do not conform to the requirements of pertinent laws, the *building official* shall reject such application in writing stating the reasons therefor. If the *building official* is satisfied that the proposed work conforms to the requirements of this code and laws applicable thereto, the *building official* shall issue a *permit* therefor as soon as practicable. [Nothing in this code limits a local municipality's ability to require application of its own ordinances or to enforce its own ordinances.](#)

R105.3.1.1 Determination of substantially improved or substantially damaged existing buildings in flood hazard areas. [This section is not adopted by the State of Oregon, Building Codes Division, as part of this code.](#)

R105.3.2 Time limitation of application. An application for a *permit* for any proposed work shall be deemed to have been abandoned 180 days after the date of filing unless such application has been pursued in good faith or a *permit* has been issued; except that the *building official* is authorized to grant one or more extensions of time for additional periods not exceeding 180 days each. The extension shall be requested in writing and justifiable cause demonstrated.

R105.4 Validity of permit. The issuance or granting of a *permit* shall not be construed to be a *permit* for, or an *approval* of, any violation of any of the provisions of this code. *Permits* presuming to give authority to violate or cancel the provisions of this code shall not be valid. The issuance of a *permit* based on *construction documents* and other data shall not prevent the *building official* from requiring the correction of errors in the *construction documents* and other data. The *building official* is

authorized to prevent occupancy or use of a structure where in violation of this code [by withholding or revoking a certificate of occupancy. Nothing in this code limits a local municipality's ability to require application of its own ordinances or to enforce its own ordinances.](#)

R105.5 Expiration. Every *permit* issued shall become invalid unless the work authorized by such *permit* is commenced within 180 days after its issuance or [if the work authorized by such permit is suspended or abandoned for a period of 180 days after the time the work is commenced.](#) The building official is authorized to grant, in writing, one or more extensions of time, for periods not more than 180 days each. The extension shall be requested in writing and justifiable cause demonstrated.

R105.6 Suspension or revocation. The *building official* is authorized to suspend or revoke a *permit* issued under the provisions of this code wherever the *permit* is issued in error or on the basis of incorrect, inaccurate or incomplete information, or in violation of any of the provisions of this code. [Nothing in this code limits a local municipality's ability to require application of its own ordinances, or to enforce its own ordinances.](#)

R105.7 Placement of permit. The building *permit* or a copy shall be kept on the site of the work until the completion of the project.

R105.8 Responsibility. It shall be the duty of every *person* who performs work for the installation or *repair* of building, structure [or](#) mechanical systems, for which this code is applicable, to comply with this code.

R105.9 Preliminary inspection. Before issuing a *permit*, the *building official* is authorized to examine or cause to be examined buildings, structures and sites for which an application has been filed.

SECTION R106 CONSTRUCTION DOCUMENTS

R106.1 Submittal documents. Submittal documents consisting of *construction documents*, and other data shall be submitted in two or more sets, [or in a digital format where allowed by the building official](#), with each application for a *permit*. Where special conditions exist, the *building official* is authorized to require additional *construction documents* [be submitted. The construction documents shall be prepared by a registered design professional where required by ORS 671 and 672.](#)

Exception: The *building official* is authorized to waive the submission of *construction documents* and other data if it is found that the nature of the work applied for is such that reviewing of *construction documents* is not necessary to obtain compliance with this code.

R106.1.1 Information on construction documents. *Construction documents* shall be drawn upon suitable material. Electronic media documents are permitted to be submitted where [approved](#) by the *building official*. *Construction documents* shall be of sufficient clarity to indicate the location, nature and extent of the work proposed and show in detail that it will conform to the provisions of this

code and relevant laws.

R106.1.2 Manufacturer's installation instructions. Manufacturer's installation instructions, as required by this code, shall be available on the job site at the time of inspection.

R106.1.3 Information on braced wall design. [Braced wall lines](#) shall be identified on the *construction documents*. Pertinent information including, but not limited to, bracing methods, location and length of *braced wall panels* and foundation requirements of *braced wall panels* at top and bottom shall be provided.

R106.1.4 Information for construction in flood hazard areas. For buildings and structures located in whole or in part in flood hazard areas as established by [the floodplain administrator](#), *construction documents* shall include:

1. Delineation of flood hazard areas, floodway boundaries and flood zones and the design flood elevation, as appropriate.
2. The elevation of the proposed lowest floor, including *basement*; in areas of shallow flooding (AO Zones), the height of the proposed lowest floor, including *basement*, above the highest adjacent *grade*.
3. The elevation of the bottom of the lowest horizontal structural member in coastal high-hazard areas (V Zone) and in Coastal A Zones where such zones are delineated on flood hazard maps or otherwise delineated by the [floodplain administrator](#).

R106.1.5 Information on storm shelters. [Construction documents for storm shelters shall include the information required in ICC 500.](#)

R106.2 Site plan or plot plan. The *construction documents* submitted with the application for *permit* shall be accompanied by a site plan showing the size and location of new construction and existing structures on the site and distances from *lot lines*. The *building official* is authorized to waive or modify the requirement for a site plan where the application for *permit* is for *alteration* or *repair* or where otherwise warranted.

R106.3 Examination of documents. The *building official* shall examine or cause to be examined [accompanying construction documents and shall ascertain by such examination whether the construction indicated and described is in accordance with the requirements of this code and other pertinent laws.](#)

R106.3.1 Approval of construction documents. Where the *building official* issues a *permit*, the *construction documents* shall be [approved](#) in writing or by a stamp that states "REVIEWED FOR CODE COMPLIANCE." One set of *construction documents* so reviewed shall be retained by the *building official*. The other set shall be returned to the applicant, shall be kept at the site of work and shall be open to inspection by the *building official* or a duly authorized representative. [Construction documents shall be approved in the timelines specified in ORS 455.467.](#)

R106.3.2 Previous approvals. This code shall not require changes in the *construction documents*, construction or designated occupancy of a structure for which a lawful *permit* has been heretofore issued or otherwise lawfully authorized, and the construction of which has been pursued in good faith within 180 days after the effective date of this code and has not been abandoned.

R106.3.3 Phased approval. The *building official* is authorized to issue a *permit* for the construction of foundations or any other part of a building or structure before the *construction documents* for the whole building or structure have been submitted, provided that adequate information and detailed statements have been filed complying with pertinent requirements of this code. The holder of such *permit* for the foundation or other parts of a building or structure shall proceed at the holder's own risk with the building operation and without assurance that a *permit* for the entire structure will be granted.

R106.3.4 Design professional in responsible charge. Where it is required that documents be prepared by a registered design professional, the building official shall be authorized to require the owner to engage and designate on the building permit application a registered design professional who shall act as the registered design professional in responsible charge. If the circumstances require, the owner shall designate a substitute registered design professional in responsible charge who shall perform the duties required of the original registered design professional in responsible charge. The building official shall be notified in writing by the owner if the registered design professional in responsible charge is changed or is unable to continue to perform the duties.

The registered design professional in responsible charge shall be responsible for reviewing and coordinating submittal documents prepared by others, including phased and deferred submittal items, for compatibility with the design of the building.

R106.4 Amended construction documents. Work shall be installed in accordance with the *approved construction documents*, and any changes made during construction that are not in compliance with the *approved construction documents* shall be resubmitted for approval as an amended set of *construction documents*.

R106.5 Retention of construction documents. One set of *approved construction documents* shall be retained by the *building official* for a period of not less than that dictated by OAR 166-150-0020 where a county has jurisdiction, OAR 166-200-0250 where a city has jurisdiction, and OAR 166-300 for jurisdictions where the State of Oregon has jurisdiction. One set of *approved plans* and specifications shall be returned to the applicant and kept on the site of the building or work at all times during which the work authorized thereby is in progress. The *building official* shall maintain a permanent record of all permits issued in flood hazard areas, including copies of inspection reports and certifications required in Section R109.1.3.

SECTION R107 TEMPORARY STRUCTURES AND USES

R107.1 General. The *building official* is authorized to issue a *permit* for temporary structures and temporary uses. Such *permits* shall be limited as to time of service, but shall not be permitted for more than 180 days. The *building official* is authorized to grant extensions for demonstrated cause.

R107.2 Conformance. Temporary structures and uses shall conform to the structural strength, fire safety, means of egress, light, *ventilation* and sanitary requirements of this code as necessary to ensure the public health, safety and general welfare.

R107.3 Temporary power. See the *Electrical Code*.

R107.4 Termination of approval. The *building official* is authorized to terminate such *permit* for a temporary structure or use and to order the temporary structure or use to be discontinued.

SECTION R108 FEES

R108.1 Payment of fees. A *permit* shall not be valid until the fees prescribed by law have been paid, nor shall an amendment to a *permit* be released until the additional fee, if any, has been paid.

R108.2 Schedule of permit fees. Permit and plan review fees shall be as adopted by the municipality, except as otherwise limited by statute. On buildings, structures and mechanical systems or *alterations* requiring a *permit*, a fee for each *permit* shall be paid as required, in accordance with the schedule as established by the municipality under authority of ORS 455.020 and 455.210, or set forth in OAR Chapter 918, Division 480 where the State of Oregon has jurisdiction.

ORS 455.020(2) is not part of this code but is reprinted here for the reader's convenience:

455.020(2) Purpose; scope of application; exceptions; scope of rules; fees by rule.

(2) The rules adopted pursuant to this chapter shall include structural standards; standards for the installation and use of mechanical, heating and ventilating devices and equipment; and standards for prefabricated structures; and shall, subject to ORS 455.210, prescribe reasonable fees for the issuance of building permits and similar documents, inspections and plan review services by the Department of Consumer and Business Services. The department may also establish, by rule, the amount of any fee pertaining to the state building code or any specialty code that is authorized by statute, but for which an amount is not specified by statute.

ORS 455.210(3)(a) is not part of this code but is reprinted here for the reader's convenience:

455.210 Fees; appeal of fees; surcharge; reduced fees; rules.

(3)(a) A municipality may adopt by ordinance or regulation such fees as may be necessary and reasonable to provide for the administration and enforcement of any specialty code or codes for which the municipality has assumed responsibility under ORS 455.148 or 455.150. A municipality shall give the director notice of the proposed adoption of a new or increased fee under this subsection. The municipality shall give the notice to the director at the time the municipality provides the opportunity for public comment under ORS 294.160 regarding the fee or, if the proposed fee is contained in an estimate of municipal budget resources, at the time notice of the last budget meeting is published under ORS 294.426.

R108.2.1 Plan review fees. Where *construction documents* are required by Section R106.1, a plan review fee shall be paid at the time of submitting the *construction documents* for plan review. Said plan review fee shall be a percentage of the building *permit* fee as established under Section R108.2. The plan review fees specified in this section are separate from the *permit* fees specified in Section R108.2 and are in addition to the *permit* fees. The state surcharge is not applied to plan review fees. When *construction documents* are incomplete or changed so as to require additional plans, an additional plan review fee shall be charged according to the rate established by the *municipality* or OAR chapter 918, division 480 where the State of Oregon has jurisdiction.

R108.3 Building permit fees. Structural and mechanical *permit* fees shall be based on the uniform fee methodologies as established by OAR 918-050-0100. Valuations used to calculate structural *permit* fees shall be based on the uniform methodology established by OAR 918-050-0100.

R108.4 Related fees. The payment of the fee for the construction *or* alteration for work done in connection to or concurrently with the work authorized by a building *permit* shall not relieve the applicant or holder of the *permit* from the payment of other fees that are prescribed by law.

[OAR 918-050-0100\(1\)\(b\) and \(c\) is not part of this code but is reprinted here for the reader's convenience:](#)

[918-050-0100 Statewide Fee Methodologies for Residential and Commercial Permits.](#)

(1) Residential construction permit fees shall be calculated using the following methodologies: [...]

(b) A mechanical permit fee shall be calculated per appliance and related equipment, with a set minimum fee.

(c) Effective January 1, 2009, a structural permit fee for new construction and additions shall be calculated using the ICC Building Valuation Data Table current as of April 1 of each year, multiplied by the square footage of the dwelling to determine the valuation. The valuation shall then be applied to the municipality's fee schedule to determine the permit fee. The plan review fee shall be based on a predetermined percentage of the permit fee set by the municipality.

(A) The square footage of a dwelling, addition, or garage shall be determined from outside exterior wall to outside exterior wall for each level.

(B) The square footage of a carport, covered porch, patio, or deck shall be calculated separately at fifty percent of the value of a private garage from the ICC Building Valuation Data Table current as of April 1.

(C) Permit fees for an alteration or repair shall be calculated based on the fair market value as determined by the building official, and then applying the valuation to the municipality's fee schedule.

Statutory/Other Authority: ORS 455.048 & 455.055

Statutes/Other Implemented: ORS 455.046 & 455.055

R108.5 Refunds. The *building official* is authorized to establish a refund policy.

R108.6 Work commencing before permit issuance. Any *person* who commences work requiring a *permit* on a building, structure, *or* mechanical system before obtaining the necessary *permits* shall be subject to [an investigation fee. The investigation](#)

[fee shall be the average or actual additional cost of ensuring that a building, structure or system is in conformance with this code and shall be in addition to the required permit fees.](#)

Exception: Work exempt from building *permit*.

SECTION R109 INSPECTIONS

R109.1 General. Construction or work for which a permit is required shall be subject to inspection by the *building official* and such construction or work shall remain accessible and exposed for inspection purposes until *approved*. Approval as a result of an inspection shall not be construed to be an approval of a violation of the provisions of this code or of other laws of the *municipality*. Inspections presuming to give authority to violate or cancel the provisions of this code or of other laws of the *municipality* shall not be valid. It shall be the duty of the permit applicant to cause the work to remain accessible and exposed for inspection purposes. Neither the *building official* nor the state shall be liable for expense entailed in the removal or replacement of any material required to allow inspection.

R109.1.1 Foundation inspection. Inspection of the foundation shall be made after poles or piers are set or trenches or *basement* areas are excavated and any required forms erected and any required reinforcing steel is in place and supported prior to the placing of concrete. The foundation inspection shall include excavations for thickened slabs intended for the support of bearing walls, partitions, structural supports, or equipment and special requirements for wood foundations.

R109.1.1.1 Concrete slab or underfloor inspection. Concrete slab or underfloor inspection shall be made after in-slab or underfloor building service equipment, conduit, piping accessories and other ancillary equipment items are in place but before any concrete is placed or floor sheathing installed, including subfloor.

R109.1.2 Mechanical and gas systems inspection. Rough inspection of mechanical, *and* gas systems shall be made prior to covering or concealment, before fixtures or *appliances* are set or installed, and prior to framing inspection.

Exception: Backfilling of ground-source heat pump loop systems tested in accordance with Section M2105.28 prior to inspection shall be permitted.

R109.1.3 Floodplain inspections. For construction in flood hazard areas as established by [the floodplain administrator, floodplain inspections and document submissions shall be determined by the floodplain administrator.](#)

R109.1.4 Frame and masonry inspection. Inspection of framing and masonry construction shall be made after the roof, masonry, framing, firestopping, draftstopping and bracing are in place and after the plumbing, mechanical and electrical rough inspections are *approved*.

R109.1.4.1 Moisture content. After the framing inspection and prior to the installation of interior finishes, the *building official* shall be notified in writing by the general contractor that all moisture-sensitive wood framing members used in construction have a moisture content of not more than 19 percent of the weight of dry wood framing members.

R109.1.5 Other inspections. In addition to inspections in Sections R109.1.1 through R109.1.4, the *building official* shall have the authority to make or require any other inspections to ascertain compliance with this code and other laws enforced by the *building official*.

R109.1.5.1 Fire-resistance-rated construction inspection.

Where fire-resistance-rated construction is required between *dwelling units* or due to location on property, the *building official* shall require an inspection of such construction after lathing or gypsum board or gypsum panel products are in place, but before any plaster is applied, or before board or panel joints and fasteners are taped and finished.

R109.1.5.2 Insulation and vapor retarder inspection.

Inspection shall be made after all insulation and required vapor retarders are in place, but before any lath or gypsum board interior wall covering is applied.

Exceptions:

1. Ceiling and floor insulation visible during final inspection.
2. The *building official* may allow the frame, insulation and vapor retarder inspections to be performed simultaneously.

R109.1.5.3 Reinforced masonry, insulating concrete form (ICF) and conventionally formed concrete wall inspection.

Reinforced masonry walls, insulating concrete form (ICF) walls and conventionally formed concrete walls located in *Seismic Design Categories D₀, D₁, D₂* and E shall be inspected after plumbing, mechanical and electrical systems embedded within the walls and reinforcing steel are in place, and prior to placement of grout or concrete. Inspection shall verify the correct size, location, spacing and lapping of reinforcing. For masonry walls, inspection shall also verify that the location of grout cleanouts and size of grout spaces comply with the requirements of this code.

R109.1.6 Final inspection. Final inspection shall be made after all work required by the building permit is completed.

R109.2 Inspection agencies. The *building official* is authorized to accept reports of *approved* agencies, provided such agencies satisfy the requirements as to qualifications and reliability.

R109.3 Inspection requests. It shall be the duty of the *building permit* holder or their duly authorized agent to notify the *building official* when work is ready for inspection. It shall be the duty of the permit holder to provide access to and means for inspection of such work that is required by this code.

OAR 918-098-1900 is not part of this code but is reprinted here for the reader's convenience:

918-098-1900 Corrective Notices—Cite-it Write-it Requirement.

In addition to any other requirements set forth in statute and rule, all building officials, inspectors and plans examiners certified under Division 098, OAR 918-225-0540, 918-281-0020, 918-695-0400, and ORS 460.055 must include an exact reference to the applicable specialty code section, Oregon administrative rule, or statute, when issuing corrective notices at construction sites or to buildings or related appurtenances during a plan review while administering or enforcing a building inspection program. The building official, inspector, or plans examiner must include a plain statement of facts upon which the citation for correction action is based.

R109.4 Approval required. Work shall not be done beyond the point indicated in each successive inspection without first obtaining the approval of the *building official*. The *building official*, upon notification, shall make the requested inspections and shall either indicate the portion of the construction that is satisfactory as completed, or shall notify the *permit* holder or their duly authorized agent of the *permit* holder wherein the same fails to comply with this code. Any portions that do not comply shall be corrected and such portion shall not be covered or concealed until authorized by the *building official*.

**SECTION R110
CERTIFICATE OF OCCUPANCY**

R110.1 Use and change of occupancy. A building or structure shall not be used or occupied **in whole or in part**, and a **change in existing character or use, or a change of occupancy** of a building or structure or portion thereof shall not be made, until the *building official* has issued a *certificate of occupancy* **for such change in character, use or occupancy.** Issuance of a certificate of occupancy shall not be construed as an approval of a violation of the provisions of this code. Nothing in this code limits a local municipality's ability to require application of its own ordinances, or to enforce its own ordinances. See OAR 918-480-0140.

Exceptions:

- Certificates of occupancy are not required for work exempt from *permits* under Section R105.2.
- Accessory buildings or structures.

R110.2 Change in use or occupancy. No change shall be made in the use or occupancy of any building that would place the building in a different division of the same group of occupancy or in a different group of occupancies unless such building is made to comply with the requirements of this code or the *Building Code* for such division or group of occupancy. Subject to the approval of the *building official*, the use or occupancy of existing buildings shall be permitted to be changed and the building is allowed to be occupied for purposes in other groups without conforming to all the requirements of this code for those groups, provided that the new or proposed use is not more hazardous, based on life and fire risk, than the existing use.

[OAR 918-480-0140](#) is not part of this code but is reprinted here for the reader's convenience:

[OAR 918-480-0140 Certificates of Occupancy — Residential](#)

[\(1\) Prior to occupancy of a new residential dwelling or townhouse the building official must issue a certificate of occupancy in the form and format established by the Division, unless a temporary certificate of occupancy is issued by the building official.](#)

[\(2\) For purposes of this rule, the terms “residential dwelling” and “townhouse” have the same meaning as in Section R202 of the Oregon Residential Specialty Code.](#)

[\(3\) Before the certificate of occupancy is issued, the general contractor or owner who was issued the structural permit for construction must provide to the building official the contact information and relevant license information for the general contractor, as well as any electrical contractor, H-VAC contractor and plumbing contractor that performed work on the residential dwelling or townhouse.](#)

[\(4\) A building official may revoke a certificate of occupancy or a temporary certificate of occupancy when the residential dwelling or townhouse is in violation of applicable law that poses a threat to health and safety. The revocation must be in writing and state the basis for the revocation of the certificate of occupancy.](#)

[Statutory/Other Authority: ORS 455.055](#)

[Statutes/Other Implemented: ORS 455.055](#)

R110.3 Certificate issued. After the *building official* inspects the building or structure and does not find violations of the provisions of this code or other laws that are enforced by the department, the *building official* shall issue a certificate of occupancy containing the following:

1. The *permit* number.
2. The address of the structure.
3. The name and address of the *owner* or the owner's authorized agent.
4. A description of that portion of the structure for which the certificate is issued.
5. A statement that the described portion of the structure has been inspected for compliance with the requirements of this code.
6. The name of the *building official*.
7. The edition of the code under which the *permit* was issued.
8. Where an automatic sprinkler system is provided and whether the sprinkler system is required.
9. Any special stipulations and conditions of the building *permit*.

R110.4 Temporary occupancy. The *building official* is authorized to issue a temporary certificate of occupancy before the completion of the entire work covered by the *permit*, provided that such portion or portions shall be occupied safely. The *building official* shall set a time period during which the temporary certificate of occupancy is valid.

R110.5 Revocation. The *building official* is authorized to suspend or revoke a certificate of occupancy [or certificate of completion](#) issued under the provisions of this code, **in writing**, wherever the certificate is issued in error, or on the basis of incorrect information supplied, or where it is determined that the building or structure or portion thereof is in violation of **the**

provisions of this code. [Nothing in this code limits a local municipality's ability to require application of its own ordinances or to enforce its own ordinances.](#)

SECTION R111 SERVICE UTILITIES

[Not adopted by the State of Oregon, Building Codes Division, as part of this code. A municipality may have authority outside of this code to regulate these matters locally, where not preempted.](#)

SECTION R112 BOARD OF APPEALS

R112.1 General. In order to hear and decide appeals of orders, decisions or determinations made by the *building official* relative to the application and interpretation of this code, [the municipality shall establish an appeals procedure.](#) [ORS 455.475 provides an alternative appeal process to that set forth by the local municipality.](#)

[ORS 455.475](#) is not part of this code but is reprinted here for the reader's convenience:

[455.475 Appeal of decision of building official.](#)

[\(1\) An applicant for a building permit may appeal a decision made by a building official under authority established pursuant to ORS 455.148, 455.150 or 455.467. The following apply to an appeal under this subsection:](#)

[\(a\) An appeal regarding the interpretation or application of a particular specialty code provision shall be made first to the appropriate specialty code chief inspector of the Department of Consumer and Business Services. The decision of the department chief inspector may be appealed to the appropriate advisory board. The decision of the advisory board may only be appealed to the Director of the Department of Consumer and Business Services if codes in addition to the applicable specialty code are at issue.](#)

[\(b\) If the appropriate advisory board determines that a decision by the department chief inspector is a major code interpretation, then the inspector shall distribute the decision in writing to all applicable specialty code public and private inspection authorities in the state. The decision shall be distributed within 60 days after the board's determination, and there shall be no charge for the distribution of the decision. As used in this paragraph, a “major code interpretation” means a code interpretation decision that affects or may affect more than one job site or more than one inspection jurisdiction.](#)

[\(2\) Except as provided in subsection \(1\) of this section, an applicant for a building permit may appeal the decision of a building official on any matter relating to the administration and enforcement of this chapter to the department. The appeal must be in writing. A decision by the department on an appeal filed under this subsection is subject to judicial review as provided in ORS 183.484.](#)

[\(3\) If an appeal is made under this section, an inspection authority shall extend the plan review deadline by the number of days it takes for a final decision to be issued for the appeal. \[2013 c.528 §13\]](#)

[Forms for appeals under ORS 455.690 and ORS 455.475 are available online at \[Oregon.gov/bcd\]\(http://Oregon.gov/bcd\).](#)

R112.2 Limitations on authority. An application for appeal shall be based on a claim that the true intent of this code or the rules legally adopted thereunder have been incorrectly interpreted, the provisions of this code do not fully apply or an equally good or better form of construction is proposed. The board shall not have authority to waive requirements of this code.

R112.3 Qualifications. [An appeals](#) board shall consist of members who are qualified by experience and training to pass judgment on matters pertaining to building construction.

R112.4 Administration. [This section is not adopted by the State of Oregon, Building Codes Division, as part of this code.](#)

SECTION R113 VIOLATIONS

R113.1 Prohibited acts. Prohibited acts are described in ORS 455.450.

[ORS 455.450 is not part of this code but is reprinted here for the reader's convenience:](#)

[455.450 Prohibited acts.](#) A person shall not:

(1) [Violate, or procure or assist in the violation of, any final order of the Director of the Department of Consumer and Business Services, an advisory board, a state administrative officer or any local appeals board, building official or inspector, concerning the application of the state building code in a particular case or concerning a license, certificate, registration or other authorization.](#)

(2) [Engage in, or procure or assist any other person to engage in, any conduct or activity for which a permit, label, license, certificate, registration or other formal authorization is required by any specialty code, any provision of ORS 446.003 to 446.200, 446.225 to 446.285, 446.395 to 446.420, 446.566 to 446.646, 446.666 to 446.746, 479.510 to 479.945, 479.950 and 480.510 to 480.670, this chapter or ORS chapter 447, 460 or 693, or any rule adopted or order issued for the administration and enforcement of those provisions, without first having obtained such permit, label, license, certificate, registration or other formal authorization.](#)

(3) [Violate, or procure or assist in the violation of, any standard, specification, requirement, prohibition or other technical provision set forth in the state building code or an applicable local building code or in any rule or order of the Department of Consumer and Business Services, an advisory board, a local governing body or local building official. \[2007 c.306 §3\]](#)

R113.2 Notice of violation. The *building official* is authorized to serve a notice of violation or order on the *person* responsible for the erection, construction, *alteration*, extension, *repair*, moving-or occupancy of a building or structure in violation of the provisions of this code, or in violation of a detail statement or a plan *approved* thereunder, or in violation of a *permit* or certificate issued under the provisions of this code. Such order shall direct the discontinuance of the illegal action or condition and the abatement of the violation.

R113.3 Prosecution of violation. If the notice of violation is not complied with in the time prescribed by such notice, the *building official* is authorized to request the legal counsel of the *municipality* to institute the appropriate proceeding at law or in

equity to restrain, correct or abate such violation, or to require the removal or termination of the unlawful occupancy of the building or structure in violation of the provisions of this code or of the order or direction made pursuant thereto.

R113.4 Violation penalties. Any *person* who violates a provision of this code or fails to comply with any of the requirements thereof or who erects, constructs, alters or repairs a building or structure in violation of the *approved construction documents* or directive of the *building official*, or of a *permit* or certificate issued under the provisions of this code, shall be subject to penalties as prescribed by law.

SECTION R114 STOP WORK ORDER

[Not adopted by the State of Oregon, Building Codes Division, as part of this code. A municipality may have authority outside of this code to regulate these matters locally, where not preempted.](#)

SECTION R115 PREFABRICATED CONSTRUCTION

R115.1 General. [See OAR Chapter 918, Division 674 for the administrative provisions of prefabricated structures as defined in ORS 455.010.](#)

[ORS 455.010\(6\) is not part of this code but is reprinted here for the reader's convenience:](#)

[455.010 Definitions](#)

(6) "Prefabricated structure":

(a) [Means a building or subassembly that has been in whole or substantial part manufactured or assembled using closed construction at an off-site location to be wholly or partially assembled on-site.](#)

(b) [Does not mean a manufactured dwelling or a small home \[...\]](#)
[\[2019 c.422 §16\]](#)

SECTION R116 INSPECTION CARD

R116.1 Record required. [The permit holder or permit holder's agent shall post the inspection record on the job site in an accessible and conspicuous place to allow the building official to make the required entries. The record shall be maintained by the permit holder until the final inspection has been made and approved. The building official may adopt local policies approving alternative inspection recording methods.](#)

SECTION R117 MOVED BUILDINGS

R117.1 Moved buildings. [See ORS 455.410.](#)

ORS 455.410 is not part of this code but is reprinted here for the reader's convenience:

455.410 Relocated buildings; substantial compliance required; permits.

(1) Existing buildings or structures which are removed from their foundation and relocated to another site within this state shall be in substantial compliance as defined in subsections (2) and (3) of this section.

(2) "Substantial compliance" means compliance with local construction codes in effect as of the original permit date of the building or structure, or where there was no permitting required at the time of original construction, with basic health and safety standards, as described in the closest dated Uniform Housing Code, as published by the International Conference of Building Officials as of the date of construction.

Only the insulation, overhead and underneath the structure, shall be upgraded to the current insulation requirements of the state building code, or to the maximum extent possible subject to the design of the structure.

Nothing in this statute shall be construed to mean that all heating, plumbing and electrical systems shall be replaced with systems meeting current standards for new construction, except that any life-threatening deficiencies in those systems shall be repaired, notwithstanding that the cost of rehabilitation may exceed 50 percent of the value of the structure before rehabilitation.

(3) All foundation and basement construction on the structure and any remodeling at the new location shall be constructed subject to all applicable local current building and safety codes, or where none exist, with the applicable standards as described in the Uniform Housing Code described in subsection (2) of this section.

(4) All moved houses shall be provided with either battery-operated or hard-wired smoke detection devices located in accordance with the provisions of the state building code.

**SECTION R118
HISTORIC BUILDINGS**

R118.1 Repairs, alterations and additions. Repairs, alterations and additions necessary for the preservation, restoration, rehabilitation or continued use of a *historic building* may be made without conforming to all of the requirements of this code where authorized by the *building official*, provided that:

1. The building has been officially designated a historic building.
2. Unsafe conditions are corrected.
3. The restored building will be no more hazardous, based on life and fire risk, than the *existing building*.
4. The *building official* seeks the advice of the State of Oregon Historic Preservation Office.

In the case of appeals related to historic buildings, the local appeals board or the appropriate state appeals board shall seek the advice of the state historic preservation officer.

Part II – Definitions

CHAPTER 2 DEFINITIONS

SECTION R201 GENERAL

R201.3 Terms defined in other codes. Where terms are not defined in this code and are defined in the *Electrical Code*, *Building Code*, *Mechanical Code* or *Plumbing Code*, such terms shall have the meanings ascribed in ~~other code publications of the International Code Council~~ those codes.

R201.4 Terms not defined. Where terms are not defined through the methods authorized by this section, such terms shall have ordinarily accepted meanings such as the context implies. Words of common usage are given their plain, natural and ordinary meanings. Words that have well-defined legal meanings are given those meanings.

SECTION R202 DEFINITIONS

Oregon-Specific Added or Amended Definitions:

ACCESSORY STRUCTURE.

A habitable or nonhabitable structure ~~not greater than 3,000 square feet (279 m²) in floor area, and not more than two stories in height, the use of which~~ is accessory to and incidental to that of the dwelling(s) and that is located on the same lot. Nonhabitable accessory structures include, but are not limited to, garages, carports, storage sheds, tool sheds and garden structures. See Section R328 for allowable area increases.

Rescinded amendments

The definition for “accessory structure” now aligns with the national model code. The definition no longer specifies 3,000 sq. ft. in area and two-story height limitations. This model code change occurred in the 2015 IRC.

2021 ORSC Section R328, Detached Group R Accessory Structures (Group U), is no longer necessary in the code and has been rescinded.

ADJACENT ROOF PLANE. For the purposes of firefighter access and escape pathway provisions, the solar roof plane is contrasted with the adjacent roof plane. To be considered an adjacent roof plane, the roof plane adjacent to the photovoltaic array installation must be free of photovoltaic panels.

In typical gable roof construction, the south-facing roof will generally be the preferred place for the installation of photovoltaic panels and it will become the solar roof plane. Where the north-facing roof plane does not contain any photovoltaic panels, it would be considered the adjacent roof plane.

AIR, EXHAUST. Air being removed from any space or piece of equipment and conveyed directly to the atmosphere by means of openings or ducts.

ALTERATION. Any construction, retrofit or renovation to an existing structure other than *repair* or *addition* that requires a *permit*. Also, a change in a building, ~~electrical, gas, or mechanical or plumbing~~ system that involves an extension, *addition* or change to the arrangement, type or purpose of the original installation that requires a *permit*. ~~For the definition applicable in Chapter 11, see Section N1101.6.~~

APPROVED FIELD EVALUATION FIRM. An organization primarily established for purposes of testing to approved

standards and approved by the local *municipality*.

AREA, BUILDING. See “*Building area*.”

AREA, FLOOR. See “*Floor area*.”

AREA, ROOF. See “*Roof area*.”

ARRAY, PHOTOVOLTAIC. See “*Photovoltaic array*.”

BALANCED VENTILATION SYSTEM. A ventilation system that simultaneously supplies outdoor air to and exhausts air from a space, where the mechanical supply airflow rate and the mechanical exhaust airflow rate are each within 10 percent of the average of the two airflow rates ~~where the total supply airflow and total exhaust airflow are simultaneously within 10 percent of their averages. The balanced ventilation system airflow is the average of the supply and exhaust airflows.~~

BALCONY, EXTERIOR. An exterior floor system projecting from and completely support by an adjoining structure without any additional supports provided to the floor system.

BASEMENT. A *story* that is not a *story above grade plane* (see “*Story above grade plane*”). A basement shall be considered as a *story above grade plane* where the finished surface of the floor above the basement is:

1. Greater than 6 feet (1829 mm) above *grade plane*; or
2. Greater than 12 feet (3658 mm) above the finished ground level at any point.

BOILER. ~~A self-contained appliance from which hot water is circulated for heating purposes and then returned to the boiler, and that operates at water pressures not exceeding 160 pounds per square inch gage (psig) (1102 kPa gauge) and at water temperatures not exceeding 250°F (121°C).~~ A closed heating appliance intended to supply hot water or steam for space heating, processing or power purposes. Low-pressure boilers operate at pressures less than or equal to 15 pounds per square inch (psi) (103 kPa) for steam and 160 psi (1103 kPa) for water. High-pressure boilers operate at pressures exceeding those pressures.

BOILER CODE. For the purposes of this code, *Boiler Code* shall mean the *Oregon Boiler and Pressure Vessel Specialty Code* as adopted by OAR 918-225-0430. The *Boiler Code* is expressly enforced by the State of Oregon Building Codes Division. Inspections and plan reviews are performed only by inspectors authorized by the state.

BRAZING. A weld produced by heating an assembly to the brazing temperature using a filler metal having a liquidus above 840°F (449°C) and below the solidus of the metals.

BTU/H. The *listed* maximum capacity of an *appliance*, absorption unit or burner expressed in British thermal units input per hour. For the definition applicable in Chapter 11, see Section N1102.

BUILDING. Any ~~one or two family low-rise residential~~ dwelling or *townhouse*, or portion thereof, used or intended to be used for human habitation, for living, sleeping, cooking or eating purposes, or any combination thereof, or any *accessory structure*. ~~For the definition applicable in Chapter 11, see Section N1101.6.~~

BUILDING AREA. The area included within surrounding exterior walls of a *dwelling* or *accessory structure*. Areas of the building not provided with surrounding walls shall be included in the *building area* if such areas are included within the horizontal projection of the roof or floor above.

BUILDING CODE. For the purposes of this code, *Building Code* shall mean the *Oregon Structural Specialty Code* as adopted by OAR 918-460-0010.

BUILDING OFFICIAL. The officer or other designated authority charged with the administration and enforcement of this code, or a duly authorized representative. ~~For the definition applicable in Chapter 11, see Section N1101.6.~~

ORS 455.715 Definitions for ORS 455.715 to 455.740.

As used in ORS 455.715 to 455.740, unless the context otherwise requires:

(1) “Building official” means a person charged by a municipality with responsibility for administration and enforcement of the state building code in the municipality.

CARPORT. A carport is a structure used to shelter a vehicle, having no enclosed uses above, and entirely open on two or more sides.

CLOTHES DRYER. An appliance used to dry wet laundry by means of heated air.

Type 1. Factory-built package, multiple production. Primarily used in the family living environment. Usually, the smallest unit physically and in function output.

COMBUSTION AIR. The air provided to fuel-burning equipment including air for fuel combustion, draft hood dilution and ventilation of the equipment enclosure. Air necessary for the complete combustion of a fuel, including theoretical air and excess air.

CONGREGATE LIVING FACILITIES. These facilities shall comply with the *Building Code*. See Section R101.2.1.

CONSTRUCTION DOCUMENTS. Written, graphic and pictorial documents prepared or assembled for describing the design, location and physical characteristics of the elements of a project necessary for obtaining a building permit.
~~Construction drawings shall be drawn to an appropriate scale.~~

CONTINUOUS AIR BARRIER. ~~For the definition applicable in Chapter 11, see Section N1101.6.~~ One or more materials sealed and joined together in a continuous manner to restrict or prevent the passage of air through the *building thermal envelope* and its assemblies.

CONTINUOUS INSULATION (ci). ~~For the definition applicable in Chapter 11, see Section N1101.6.~~ Insulating material that is continuous across all structural members without thermal bridges other than fasteners and service openings. It is installed on the interior or exterior, or is integral to any opaque surface, of the *building envelope*.

CONVENTIONAL LIGHT-FRAME CONSTRUCTION. Construction whose primary structural elements are formed by a system of repetitive wood-framing members.

COURT. ~~A space, open and unobstructed to the sky, located at or above grade level on a lot and bounded on three or more sides by walls or a building.~~ An open, uncovered space, unobstructed to the sky, bounded on three or more sides by exterior building walls or other enclosing devices.

COVERED MULTIFAMILY DWELLINGS. See ORS 447.210(5). As part of this code, “Covered multifamily dwellings” are applicable only to covered multifamily dwellings designed and constructed for first occupancy after March 13, 1991, or where the last building permit or renewal thereof was issued on or before June 15, 1990. For the purposes of application, “first occupancy” means “a building that has never before been used for any purpose.”

ORS 447.210(5) is not a part of this code but is reprinted here for the reader’s convenience:

447.210 Definitions.

(5) “Covered multifamily dwellings” means buildings consisting of four or more dwelling units if such buildings have one or more elevators, and ground floor dwelling units in other buildings consisting of four or more dwelling units. Dwelling units within a single structure separated by firewalls do not constitute separate buildings.

CRIPPLE WALL. A framed stud wall that is less than 96 inches (2438 mm) in height extending from the top of a concrete or masonry ~~the~~ foundation to the underside of the floor framing or the top of a daylight basement concrete or masonry foundation wall to the underside of the framing above ~~of the first story above grade plane~~.

CUTOUT. An area adjacent to a pathway for use by fire-fighters to cut a vent if needed. *Cutouts* shall not be less than 30 inches (762 mm) in any dimension.

DECK.

Attached deck. An exterior floor system supported on at least one side by the exterior wall of the adjoining structure and supported on the opposing side by posts, piers or other support methods.

Detached deck. An exterior floor system not anchored to a structure and provided with its own independent support system.

DESIGN FLOOD ELEVATION. The elevation of the “design flood,” including wave height, relative to the datum specified on the community’s legally designated flood hazard map as determined by the *floodplain administrator*.

~~**DIAPHRAGM.** A horizontal or nearly horizontal system acting to transmit lateral forces to the vertical resisting elements. Where the term “diaphragm” is used, it includes horizontal bracing systems~~ A roof or floor system designed to transmit lateral forces to shear walls or other lateral load-resisting elements.

ELECTRICAL CODE. For the purposes of this code, *Electrical Code* shall mean the *Oregon Electrical Specialty Code* as adopted by OAR 918-305-0100.

ELEVATOR CODE. For the purposes of this code, *Elevator Code* shall mean the *Oregon Elevator Specialty Code* as adopted by OAR 918-400-0455. The *Elevator Code* is expressly enforced by the Oregon Building Codes Division. Inspections and plan reviews are performed only by inspectors authorized by the state.

ENGINEERED DESIGN. A design in accordance with the accepted engineering practices prepared by a *registered design professional*.

~~**EXTERIOR WALL.** For the definition applicable in Chapter 11, see Section N1101.6.~~ A wall that is used as an enclosing wall for a building, other than a fire wall, and that has a slope of 60 degrees (1.05 rad) or greater with the horizontal plane.

~~**FIREPLACE.** An assembly consisting of a hearth and fire chamber of noncombustible material and provided with a chimney, for use with solid fuels.~~ A hearth and fire chamber or similar prepared place in which a fire may be made, and which is built in conjunction with a chimney.

FLOOD HAZARD AREA. An area determined by the *floodplain administrator* as a flood hazard area.

FLOODPLAIN ADMINISTRATOR. See Section R102.4.1.

~~**FLOOR AREA.** The area within the inside perimeter of the walls of the room or space under consideration. The floor area of a room or space not provided with surrounding exterior walls shall be the usable area under the horizontal projection of the roof or floor above.~~

FLUE. See “Vent.” A passageway within a chimney or vent through which gaseous products of combustion pass.

GABLE. The triangular portion of a wall beneath the end of a dual-slope, pitched, or mono-slope roof or portion thereof and above the top plates of the story or level of the ceiling below.

GROUND SNOW LOAD, *p_g*. The site-specific weight of the accumulated snow at the ground level. It generally has a 50-year mean recurrence interval.

GYPSUM BOARD. The generic name for a family of sheet products consisting of a noncombustible core primarily of gypsum with paper surfacing. Gypsum wallboard, gypsum sheathing, gypsum base for gypsum *vener* plaster, exterior gypsum soffit board, predecorated gypsum board and water-resistant gypsum backing board complying with the standards listed in Section R702.3 ~~and Part IX~~ of this code are types of gypsum board.

~~**HEIGHT, STORY.** The vertical distance from top to top of two successive tiers of beams or finished floor surfaces; and, for the topmost story, from the top of the floor finish to the top of the ceiling joists or, where there is not a ceiling, to the top of the roof rafters.~~ For stories below the topmost story, the vertical distance from top to top of two successive tiers of beams or finished floor surfaces. For the topmost story, the vertical distance measured along the exterior face of the exterior wall at the tallest roof eave, from the top of the floor finish to the top of the ceiling joists, or where there are no ceiling joists (vaulted ceiling) to the top of the

[roof rafters.](#)

JURISDICTION. ~~The governmental unit that has adopted this code.~~ [See “municipality.”](#)

LIVE/WORK UNIT. A *dwelling unit* or sleeping unit in which a significant portion of the space includes a nonresidential use that is operated by the tenant. [Offices that are less than 10 percent of the area of the *dwelling unit* are not considered live/work units.](#)

LODGING HOUSE. ~~A one-family dwelling where one or more occupants are primarily permanent in nature, and rent is paid for guestrooms.~~ [A detached one-family dwelling where one or more occupants are primarily permanent in nature, and containing not more than five guestrooms, where rent is paid in money, goods, labor or otherwise. The total number of guests shall not exceed 16. *Lodging houses* include “bed and breakfast” and similar use.](#)

MANUFACTURED HOME. ~~A structure, transportable in one or more sections, that in the traveling mode is 8 body feet (2438 body mm) or more in width or 40 body feet (12 192 body mm) or more in length, or, where erected on site, is 320 square feet (30 m²) or more, and that is built on a permanent chassis and designed to be used as a *dwelling* with or without a permanent foundation where connected to the required utilities, and includes the plumbing, heating, air conditioning and electrical systems contained therein; except that such term shall include any structure that meets all the requirements of this paragraph except the size requirements and with respect to which the manufacturer voluntarily files a certification required by the secretary (HUD) and complies with the standards established under this title. For mobile homes built prior to June 15, 1976, a label certifying compliance to the Standard for Mobile Homes, NFPA 501, in effect at the time of manufacture is required. For the purpose of these provisions, a mobile home shall be considered to be a *manufactured home*.~~ [See ORS 446.003\(23\).](#)

[ORS 446.003\(23\) is not part of this code but is reprinted here for the reader’s convenience:
446.003 Definitions for ORS 446.003 to 446.200 and 446.225 to 446.285 and ORS Chapters 195, 196, 197, 215 and 227.](#)

[ORS 446.003\(23\)](#)

[\(a\) “Manufactured home,” except as provided in paragraph \(b\) of this section, means a structure constructed for movement on the public highways that has sleeping, cooking and plumbing facilities, that is intended for human occupancy, that is being used for residential purposes and that was constructed in accordance with federal manufactured housing construction and safety standards and regulations in effect at the time of construction.](#)

[\(b\) For purposes of implementing any contract pertaining to manufactured homes between the department and the federal government, “manufactured home” has the meaning given the term in the contract.](#)

MASONRY HEATER. A masonry heater is a ~~solid fuel-burning~~ heating *appliance* constructed predominantly of concrete or *solid masonry* ~~that having a mass of not less than 1,100 pounds (500 kg), excluding the chimney and foundation. It is designed to absorb and store a substantial portion of heat from a solid fuel fire built in the firebox by routing exhaust gases through internal heat exchange channels in which the flow path downstream of the firebox may include includes not less than one 180-degree (3.14 rad) change in flow in a horizontal or downward direction before entering the chimney and that deliver heat by radiation through from~~ the masonry surface of the heater.

MECHANICAL CODE. For the purposes of this code, *Mechanical Code* shall mean the *Oregon Mechanical Specialty Code* as adopted by OAR 918-440-0010.

MEMBRANE-COVERED FRAME STRUCTURE. ~~A nonpressurized building wherein the structure is composed of a rigid framework to support a tensioned membrane that provides the weather barrier.~~

MUNICIPALITY. Shall be as defined in ORS 455.010.

[ORS 455.010 is not part of this code but is reprinted here for the reader’s convenience.](#)

[455.010 Definitions for ORS Chapter 455. As used in this chapter, unless the context requires otherwise:](#)

[\(5\) “Municipality” means a city, county or other unit of local government otherwise authorized by law to administer a building code.](#)

NATURALLY DURABLE WOOD. The heartwood of the following species with the exception that an occasional piece with corner sapwood is permitted if 90 percent or more of the width of each side on which it occurs is heartwood.

Decay resistant. Redwood, cedar, black locust, [Western juniper](#) and black walnut.

Termite resistant. Alaska yellow cedar, redwood, Eastern red cedar, [Western juniper](#) and Western red cedar including all sapwood of Western red cedar.

NONPRESCRIPTIVE DESIGN. The design of structural elements exceeding the limits of Section R301 or otherwise not conforming to the prescriptive provisions of this code. The design shall result in a system capable of supporting the loads prescribed in this code or the *Building Code* and provide a complete load path that transfers those loads from their points of origin through the load-resisting elements and foundation to the supporting soil (see Section R301.1.3). The design is either an *engineered design* or a design deemed adequate by the *building official* and not required to be prepared by a *registered design professional* in accordance with ORS 671 and 672.

PHOTOVOLTAIC ARRAY. A mechanically integrated assembly of modules or panels with a support structure, foundation, tracker and other components, as required, to form a power-producing unit.

PHOTOVOLTAIC RACKING. A system of components that directly supports the *photovoltaic modules* and transfers the applied *loads* to the building structure or ground-supported structure.

PHOTOVOLTAIC SOLAR ENERGY SYSTEM. The total components and subsystems that, in combination, convert solar energy into electric energy suitable for connection to a utilization load.

PLUMBING CODE. For the purposes of this code, *Plumbing Code* shall mean the *Oregon Plumbing Specialty Code* as adopted by OAR 918-750-0110.

REGISTERED DESIGN PROFESSIONAL. An individual who is registered or licensed to practice their respective design profession as defined by the statutory requirements of the professional registration laws of the state ~~or jurisdiction~~ in which the project is to be constructed.

RESIDENTIAL AIRCRAFT HANGAR. An *accessory structure* less than 2,000 square feet (186 m²) and 20 feet (6096 mm) in *building height* constructed on a one- or two-family property where aircraft is stored. Such use shall be considered as a residential accessory use incidental to the dwelling.

ROOF AREA. The square footage of roof measured in plan view separated by *fire walls* or *exterior walls* and sharing a common *attic* or *fire area* below.

SEISMIC DESIGN CATEGORY (SDC). A classification assigned to a structure based on its occupancy category and the severity of the design earthquake ground motion at the site (see Section R301.2.2.1).

SHAFT. An enclosed space extending through one or more stories of a building, connecting vertical openings in successive floors, or floors and roof.

SHAFT ENCLOSURE. The walls or construction forming the boundaries of a shaft.

SHEAR WALL. ~~A general term for walls that are~~ A wall designed and constructed to resist lateral forces parallel to the plane of the wall, racking from seismic and wind by use of masonry, concrete, cold formed steel or wood framing in accordance with Chapter 6 of this code and the associated limitations in Section R301.2 of this code.

SMALL HOME SPECIALTY CODE. For the purposes of this code, *Small Home Specialty Code* shall mean the specialty code adopted under Section 2(2), Chapter 401, Oregon Laws 2019.

Oregon Laws 2019, Chapter 401, Section 2(2) is not part of this code but is reprinted here for the reader's convenience:

(2) Notwithstanding ORS 455.020 and 455.030, the 2018 International Residential Code, including but not limited to Appendix Q of that code, is adopted as a Small Home Specialty Code applicable to the construction of a small home.

SOLAR ROOF PLANE. A roof plane on which a *photovoltaic array* is installed. A *solar roof plane* does not include building-integrated photovoltaic solar shingles.

SOLID MASONRY. ~~Load bearing or nonload bearing construction using masonry units where the net cross sectional area~~

~~of each unit in any plane parallel to the bearing surface is not less than 75 percent of its gross cross-sectional area. Solid masonry units shall conform to ASTM C55, C62, C73, C145 or C216. Masonry units whose net cross-sectional area in every plane parallel to the load-bearing surface is 75 percent or more of its gross cross-sectional area measured in the same plane.~~

STATE BUILDING CODE. The combined specialty codes adopted pursuant to ORS 455 and any code regulation or requirement in effect at the time of construction, regardless of when the building or structure was built.

STORY. That portion of a building included between the upper surface of a floor and the upper surface of the floor or roof next above, except that the topmost story shall be that portion of the building included between the upper surface of the topmost floor and the ceiling or roof above. If the finished floor level directly above a usable or unused underfloor space is more than 6 feet (1829 mm) above grade, as defined herein, for more than 50 percent of the total perimeter or is more than 12 feet (3658 mm) above grade, as defined herein, at any point, such usable or unusable underfloor space shall be considered as a story.

STRUCTURALLY DEPENDENT BUILDING. Town-houses in which individual units are designed to rely on adjacent units for structural support of vertical or lateral loads.

STRUCTURALLY INDEPENDENT BUILDING. Town-houses in which individual units are designed to have independent vertical and lateral load-resisting systems capable of resisting all applied directional loads.

SWIMMING POOL. Any structure intended for swimming or recreational bathing that contains water over 24 inches (610 mm) deep. This includes in-ground, above-ground and on-ground swimming pools, hot tubs and spas.

THERMAL ISOLATION. ~~For the definition applicable in Chapter 11, see Section N1101.6. A separation of conditioned spaces, between a sunroom addition and a dwelling unit, consisting of existing or new wall(s), doors, and/or windows.~~

THERMAL RESISTANCE, R-VALUE. ~~See "R value."~~ For the definition applicable in Chapter 11, see Section N1102.

THERMAL TRANSMITTANCE, U-FACTOR. ~~See "U factor."~~ For the definition applicable in Chapter 11, see Section N1102.

TOTAL SOLAR RESOURCE FRACTION (TSRF). The fraction of usable solar energy that is received by the solar panel/collector throughout the year. This accounts for the impacts due to external shading, collector tilt and collector orientation.

TOWNHOUSE. ~~A building that contains three or more attached townhouse units. A single-family dwelling unit constructed in a group of three or more attached units in which each unit extends from foundation to roof and with a yard or public way on not less than two sides.~~

VAPOR RETARDER. A vapor-resistant material, membrane or covering such as foil, plastic sheeting or insulation that limits the amount of moisture vapor that passes through a material.

WHOLE-HOUSE MECHANICAL VENTILATION SYSTEM. ~~An exhaust system, supply system, or combination thereof that is designed to mechanically exchange indoor air for outdoor air where operating continuously or through a programmed intermittent schedule to satisfy the whole-house ventilation rate. For the definition applicable in Chapter 11, see Section N1101.6. Combination of supply fan systems and exhaust fan systems designed to mechanically exchange indoor air for outdoor air where operating continuously or through a programmed intermittent schedule to provide a balanced ventilation system that satisfies the whole-house ventilation requirements of Chapter 15.~~

WIND SPEED, V. Basic design wind speeds.

WIND SPEED, V_{asd} . Allowable stress design wind speeds.

WOOD STRUCTURAL PANEL. A panel manufactured from veneers, or wood strands or wafers, or a combination of veneer and wood strands or wafers bonded together with waterproof synthetic resins or other suitable bonding systems. Examples of wood structural panels are plywood, orientated strand board (OSB) or composite panels.

Composite panels. A wood structural panel that is composed of wood veneer and reconstituted wood-based material and

bonded together with waterproof adhesive.

Oriented strand board (OSB). A mat-formed wood structural panel composed of thin rectangular wood strands arranged in cross-aligned layers with surface layers normally arranged in the long panel direction and bonded with waterproof adhesive.

Plywood. A wood structural panel composed of plies of wood veneer arranged in cross-aligned layers. The plies are bonded with waterproof adhesive that cures on application of heat and pressure.

Deleted 2021 IRC Definitions

Above-Grade Wall.
Air Admittance Valve.
Air Barrier.
Air Break (Drainage System).
Air Gap, Drainage System.
Air Gap, Water-Distribution System
Antisiphon.
Approved Source.
Automatic.
Backflow, Drainage.
Backflow, Water Distribution.
Backflow Preventer.
Backflow Preventer, Reduced-Pressure-Zone Type.
Backpressure.
Backpressure, Low Head.
Backsiphonage.
Backwater Valve.
Balanced Ventilation.
Basement Wall.
Basic Wind Speed.
Bathroom Group.
Bend.
Branch.
Branch, Fixture.
Branch, Horizontal.
Branch, Main.
Branch, Vent.
Branch Interval.
Building Drain.
Building Line.
Building Sewer.
Building Site.
Building Thermal Envelope.
Circuit Vent.
Cleanout.
Common Vent.
Conditioned Floor Area.
Contamination.
Continuous Waste.
Continuously Burning Pilot Light.
Crawl Space Wall.
Curtain Wall.
Demand Recirculation Water System.
Developed Length.
Drain.
Drainage Fitting.
Duct.
DWV.
Effective Opening.
Elbow.
Energy Analysis.
Energy Cost.
Energy Simulation Tool.
Equivalent Length.
ERI Reference Design.
Existing Installations.
Fenestration Product, Site-Built.
Fixture.
Fixture Branch, Drainage.
Fixture Branch, Water-Supply.
Fixture Drain.
Fixture Fitting.
Fixture Group, Main.
Fixture Supply.
Fixture Unit, Drainage (D.F.U.).
Fixture Unit, Water-Supply (W.S.F.U.).
Flood-Level Rim.
Floor Drain.
Flow Pressure.
Flush Valve.
Flushometer Tank.
Flushometer Valve.
Full-Open Valve.
Fullway Valve.
Grade, Piping.
Graywater.
Gridded Water Distribution System.
Heated Slab.
High-Efficacy Light Sources.
Horizontal Branch, Drainage.
Horizontal Pipe.
Hot Water.
Hurricane-Prone Regions.
Indirect Waste Pipe.
Individual Sewage Disposal System.
Individual Vent.
Individual Water Supply.
Infiltration.
Low-Voltage Lighting.
Macerating Toilet Systems.
Main.
Main Sewer.
Manifold Water Distribution Systems.
Manual.
Offset.
On-Site Nonpotable Water Reuse Systems.
Opaque Door.
Pitch.
Plumbing.
Plumbing Appliance.
Plumbing Appurtenance.
Plumbing Fixture.
Plumbing Systems.
Pollution.
Potable Water.
Pressure-Relief Valve.
Proposed Design.
Public Sewer.
Public Water Main.
Quick-Closing Valve.
Rated Design.
Ready Access (To).
Receptor.
Reclaimed Water.
Residential Building.
Riser (Plumbing).
Riser (Stair).
Rough-In.
Sanitary Sewer.
Septic Tank.
Service Water Heating.
Sewage.
Sewage Pump.
Skylight.
Slip Joint.
Slope.
Soil Stack or Pipe
Solar Heat Gain Coefficient (SHGC).
Stack.
Stack Vent.
Standard Reference Design.
Storm Sewer, Drain.
Sump.
Sump Pump.
Sweep.
Temperature- And Pressure-Relief (T and P) Valve.
Townhouse Unit.
Trap.
Trap Arm.
Trap Primer.
Trap Seal.
Vacuum Breaker.
Vent Stack.
Vent System.
Ventilation Air.
Visible Transmittance (Vt).
Waste.
Waste Pipe or Stack.
Waste Receptor.
Water Distribution System.
Water Heater.
Water Main.
Water Outlet.
Water Service Pipe.
Water Supply System.
Wet Vent.
Windborne Debris Region.
Zone.

Part III – Building Planning and Construction

CHAPTER 3 BUILDING PLANNING

SECTION R301 DESIGN CRITERIA

New amendments

Newly defined terms have been added to clarify design requirements: “nonprescriptive design” and “engineered design.”

Related sections throughout the code have been changed to align.

Resources for ORS 671 and 672:

- Oregon State Board of Examiners for Engineering and Land Surveying – OSBEELS:
<https://www.oregon.gov/osbeels/resources/>
- Oregon State Board of Architect Examiners – OSBAE:
<https://www.oregon.gov/osbae/>
- Reference manual for building officials- New 2022 edition:
<https://www.oregon.gov/osbae/Documents/Reference-Manual-for-Building-Officials.pdf>

NONPRESCRIPTIVE DESIGN. The design of structural elements exceeding the limits of Section R301 or otherwise not conforming to the prescriptive provisions of this code. The design shall result in a system capable of supporting the loads prescribed in this code or the *Building Code* and provide a complete load path that transfers those loads from their points of origin through the load-resisting elements and foundation to the supporting soil. (See Section R301.1.3). The design is either an *engineered design*, or a design deemed adequate by the *building official* and not required to be prepared by a *registered design professional* in accordance with ORS 671 and 672.

ENGINEERED DESIGN. A design in accordance with the accepted engineering practices prepared by a *registered design professional*.

R301.1.1 Alternative provisions. As an alternative to the requirements in Section R301.1, the following standards are permitted subject to the limitations of this code and the limitations therein. Where *nonprescriptive design* ~~engineered design~~ is used in conjunction with these standards, the design shall comply with the *Building Code*.

1. AWC *Wood Frame Construction Manual* (WFCM).
2. AISI *Standard for Cold-Formed Steel Framing—Prescriptive Method for One- and Two-Family Dwellings* (AISI S230).
3. ICC *Standard on the Design and Construction of Log Structures* (ICC 400).

R301.1.3 ~~Engineered design~~ Nonprescriptive design. Where a building of otherwise conventional construction contains structural elements exceeding the limits of Section R301 or otherwise not conforming to this code, *nonprescriptive design* of these elements ~~is required~~ ~~shall be designed in accordance with accepted engineering practice~~. The extent of such ~~design~~ *nonprescriptive design* need only demonstrate compliance of nonconventional elements with other applicable provisions and shall be compatible with the performance of the conventional framed system. ~~Engineered d~~ Design in accordance with the *Building Code* is permitted for buildings and structures, and parts thereof, included in the scope of this code.

Rescinded 2021 ORSC amendment

~~Where a design, in accordance with accepted engineering practice, is provided for a structure or portions thereof, the design values and limitations of Sections R301.5, R301.6, and R301.7 shall apply. All other structural design requirements shall be in accordance with Chapter 16 of the Building Code, as applicable.~~

**Section R301.1.4
Model code change:**

A new section was added pointing to the Building Code (Oregon Structural Specialty Code) for the repurposing of intermodal shipping containers for use as buildings or structures.

A new definition was also added for Intermodal shipping container.

INTERMODAL SHIPPING CONTAINER. A six-sided steel unit originally constructed as a general cargo container used for the transport of goods and materials.

R301.1.4 Intermodal shipping containers. Intermodal shipping containers that are repurposed for use as buildings or structures shall be designed in accordance with the structural provisions in Section ~~3114~~ of the *Building Code*.

R301.2 Climatic and geographic design criteria. Buildings shall be constructed in accordance with the provisions of this code as limited by the provisions of this section and the additional criteria ~~shall be established by the local jurisdiction and~~ set forth in Table R301.2.

IRC Figure R301.2(1) Weathering Probability Map for concrete. ...*Not adopted.*

IRC Figure R301.2(2) Ultimate Design Wind Speeds. ...*Not adopted.*

IRC Figure R301.2(3) and R301.2(4) Ground Snow Loads for the US. ...*Not adopted.*

R301.2.1 Wind design criteria. Buildings and portions thereof shall be constructed in accordance with the wind provisions of this code using the basic design wind speed, V , in Table R301.2. ~~The structural provisions of this code for wind loads are not permitted where wind design is required as specified in Section R301.2.1.1. Areas of special wind regions in Table R301.2 shall be identified using Figure R301.2.1(1).~~ Where different construction methods and structural materials are used for various portions of a building, the applicable requirements of this section for each portion shall apply. Where not otherwise specified, the wind loads listed in Table R301.2.1(1) adjusted for height and exposure using Table R301.2.1(2) shall be used to determine design load performance requirements for wall coverings, curtain walls, roof coverings, exterior windows, skylights, garage doors and exterior doors. Asphalt shingles shall be designed for wind speeds in accordance with Section R905.2.4. *Metal roof shingles shall be designed for wind speeds in accordance with Section R905.4.4.* A continuous load path shall be provided to transmit the applicable uplift forces in Section R802.11 from the *roof assembly* to the foundation. *Where basic design wind speeds, V , in Table R301.2 are less than the lowest wind speed indicated in the prescriptive provisions of this code, the lowest wind speed indicated in the prescriptive provisions of this code shall be used. Where the Building Code is used for the design of the building or structure, wind loads shall be determined in accordance with Section 1609 of the Building Code.*

Section R301.2.1 – New amendment:

A reference has been added to connect the identification of a special wind region in Figure R301.2.1(1) and the ASCE 7 Hazard Tool with the determination of the basic design wind speeds in Table R301.2.

IRC R301.2.1.1 Wind limitations and wind design required. ...*Not adopted.*

IRC R301.2.1.2 Protection of openings. & Table R301.2.1.2. ...*Not adopted.*

R301.2.1.2 R301.2.1.3 Wind speed conversion. Where referenced documents are based on allowable stress nominal design wind speeds, V_{asd} , and do not provide the means for conversion between basic design wind speeds, V , and allowable stress nominal design wind speeds, V_{asd} , the basic design wind speeds, V , shall be converted to allowable stress nominal design wind speeds, V_{asd} , using Table R301.2.1.2.

**TABLE R301.2.1.2 R301.2.1.3
WIND SPEED CONVERSIONS^a**

<u>V (mph)</u>	90	95	100	105	110	115	120	125	130	135
<u>V_{asd}</u>	70	74	77	81	85	89	93	97	101	105

For SI: 1 mile per hour = 0.447 m/s.

a. Linear interpolation is permitted.

R301.2.1.3 ~~**R301.2.1.4**~~ **Exposure category.** For each wind direction considered, an exposure category that adequately reflects the characteristics of ground surface irregularities shall be determined for the site at which the building or structure is to be constructed. For a site located in the transition zone between categories, the category resulting in the largest wind forces shall apply. Account shall be taken of variations in ground surface roughness that arise from natural topography and vegetation as well as from constructed features. *[The rest of this section is deleted]*

R301.2.1.3.1 **Wind directions and sectors.** For each selected wind direction at which the wind loads are to be evaluated, the exposure of the building or structure shall be determined for the two upwind sectors extending 45 degrees (0.79 rad) either side of the selected wind direction. The exposures in these two sectors shall be determined in accordance with Sections R301.2.1.3.2 and R301.2.1.3.3, and the exposure resulting in the highest wind loads shall be used to represent winds from that direction.

R301.2.1.3.2 **Surface roughness categories.** For the purpose of assigning an exposure category as defined in Section R301.2.1.3.3, a ground surface roughness within each 45-degree (0.79 rad) sector shall be determined for a distance upwind of the site from the following categories:

Surface Roughness B. Urban and suburban areas, wooded areas or other terrain with numerous closely spaced obstructions having the size of single-family dwellings or larger.

Surface Roughness C. Open terrain with scattered obstructions having heights generally less than 30 feet (9144 mm). This category includes flat, open country and grasslands.

Surface Roughness D. Flat, unobstructed areas and water surfaces. This category includes smooth mud flats, salt flats and unbroken ice.

R301.2.1.3.3 **Exposure categories.** An exposure category shall be determined in accordance with the following:

Exposure B. Exposure B shall apply where the ground surface roughness, as defined by Surface Roughness B, prevails in the upwind direction for a distance of not less than 1,500 feet (457 m).

Exposure C. Exposure C shall apply for all cases where Exposure B or D does not apply.

Exposure D. Exposure D shall apply where the ground surface roughness, as defined by Surface Roughness D, prevails in the upwind direction for a distance of not less than 5,000 feet (1524 m) or 20 times the height of the building, whichever is greater. Exposure D shall apply where the ground surface roughness immediately upwind of the site is B or C, and the site is within a distance of 600 feet (183 m) or 20 times the building height, whichever is greater, from an Exposure D condition as defined in the previous sentence.

IRC R301.2.1.5 Topographic wind effects. ...Not adopted.

IRC R301.2.1.5.1 Simplified topographic wind speed-up method. ...Not adopted.

IRC Table R301.2.1.5.1 ...Not adopted.

IRC Figure R301.2.1.5.1(1) ...Not adopted.

IRC Figure R301.2.1.5.1(2) ...Not adopted.

IRC Figure R301.2.1.5.1(3) ...Not adopted.

Table R301.2 amendment updates: Special wind region basic design wind speeds have been updated.

Errata—April 2024
Special Wind Region Basic Design Wind Speed values were mistakenly omitted from the table.

TABLE R301.2
CLIMATIC AND GEOGRAPHIC DESIGN CRITERIA^{f, g}

COUNTY	GROUND SNOW LOAD, p_g	BASIC DESIGN WIND SPEED, V (mph) ^b	SPECIAL WIND REGION BASIC DESIGN WIND SPEED, V (mph) ^b	SEISMIC DESIGN CATEGORY	SUBJECT TO DAMAGE			AIR FREEZING INDEX
					Weathering ^d	Frost line depth (inches)	Decay	
Baker	Note a	103	-	Note c	Severe	24	Slight	2,000
Benton	Note a	96	120	Note c	Moderate	12	Moderate	≤ 1,500
Clackamas	Note a	98	98	Note c	Moderate	12	Moderate	≤ 1,500
Clatsop	Note a	96	120	Note c	Moderate	12	Moderate	≤ 1,500
Columbia	Note a	97	97	Note c	Moderate	12	Moderate	≤ 1,500
Coos	Note a	95	120	Note c	Moderate	12	Moderate	≤ 1,500
Crook	Note a	100	100	Note c	Severe	18	Slight	2,000
Curry	Note a	94	120	Note c	Moderate	12	Moderate	≤ 1,500
Deschutes	Note a	99	99	Note c	Severe	18	Slight	≤ 1,500
Douglas	Note a	97	120	Note c	Moderate	18	Moderate	≤ 1,500
Gilliam	Note a	100	-	Note c	Severe	24	Moderate	≤ 1,500
Grant	Note a	101	-	Note c	Severe	24	Slight	2,000
Harney	Note a	101	-	Note c	Severe	24	Moderate	2,000
Hood River	Note a	98	98	Note c	Severe	24	Moderate	≤ 1,500
Jackson	Note a	96	-	Note c	Moderate	18 ^e	Slight	≤ 1,500
Jefferson	Note a	99	99	Note c	Severe	18	Moderate	≤ 1,500
Josephine	Note a	95	-	Note c	Moderate	18 ^e	Moderate	≤ 1,500
Klamath	Note a	98	98	Note c	Severe	24	Moderate	≤ 1,500
Lake	Note a	99	-	Note c	Severe	24	Slight	≤ 1,500
Lane	Note a	98	120	Note c	Moderate	12	Moderate	≤ 1,500
Lincoln	Note a	96	120	Note c	Moderate	12	Moderate	≤ 1,500
Linn	Note a	98	-	Note c	Moderate	12	Moderate	≤ 1,500
Malheur	Note a	102	-	Note c	Severe	24	Slight	≤ 1,500
Marion	Note a	98	-	Note c	Moderate	12	Moderate	≤ 1,500
Morrow	Note a	101	-	Note c	Severe	24	Slight	≤ 1,500
Multnomah	Note a	98	98	Note c	Moderate	18 ^e	Moderate	≤ 1,500
Polk	Note a	97	-	Note c	Moderate	12	Moderate	≤ 1,500
Sherman	Note a	99	-	Note c	Severe	24	Slight	≤ 1,500
Tillamook	Note a	96	120	Note c	Moderate	12	Moderate	≤ 1,500
Umatilla	Note a	102	-	Note c	Severe	24	Slight	≤ 1,500
Union	Note a	102	-	Note c	Severe	24	Slight	≤ 1,500
Wallowa	Note a	103	-	Note c	Severe	24	Slight	≤ 1,500
Wasco	Note a	99	99	Note c	Severe	24	Slight	≤ 1,500
Washington	Note a	97	-	Note c	Moderate	12	Moderate	≤ 1,500
Wheeler	Note a	100	-	Note c	Severe	24	Slight	≤ 1,500
Yamhill	Note a	97	120	Note c	Moderate	12	Moderate	≤ 1,500

For SI: 1 inch = 25.4 mm.

- a. The ground snow load, p_g , shall be determined in accordance with Section R301.2.3.1.
- b. Sites located within a special wind region, as determined from Figure R301.2.1(1), shall use the special wind region basic design wind speeds provided herein.
- c. The seismic design category shall be determined in accordance with Section R301.2.2.1.
- d. A “severe” classification is where weather conditions result in significant snowfall combined with extended periods during which there is little or no natural thawing, causing de-icing salts to be used extensively.
- e. The frost line depth for site elevations below 2,500 feet in Jackson, Josephine and Multnomah Counties is 12 inches.
- f. See Sections R301.2.4 and R322 for flood plain administrator determinations and flood hazard design criteria.
- g. See Section R327 for establishment of wildfire hazard mitigation design requirements.

[Footnotes h, i and j have been rescinded.]

Figure R301.2.1(1) amendment updates: Special wind region basic design wind speeds have been updated.

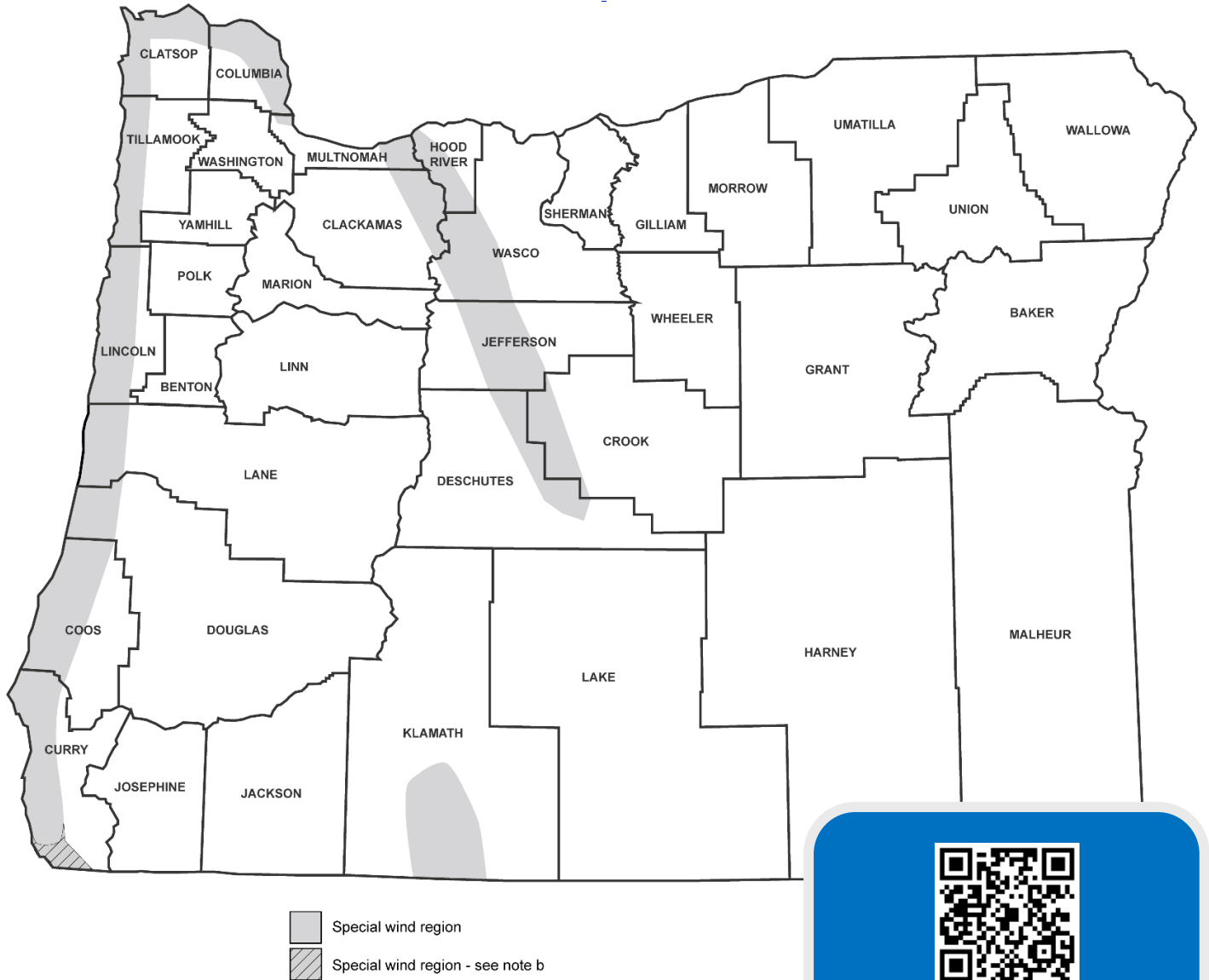

For SI: 1 mile per hour = 0.447 m/s .

FIGURE R301.2.1(1)
SPECIAL WIND REGIONS—OREGON^{a, b}

- a. Sites on the perimeter of the identified special wind regions shall be verified using the ASCE 7 Hazard Tool: <https://asce7hazardtool.online/>.
- b. This portion of the special wind region in Curry County extends 15 miles inland from the Pacific Coast and is not identified on the ASCE 7 Hazard Tool.

R301.2.2 Seismic provisions. Buildings in *Seismic Design Categories* C, D₀, D₁ and D₂ shall be constructed in accordance with the requirements of this section and other seismic requirements of this code. The seismic provisions of this code shall apply as follows:

1. *Townhouses* in *Seismic Design Categories* C, D₀, D₁ and D₂.
2. Detached one- and two-family *dwelling*s in *Seismic Design Categories*, D₀, D₁ and D₂.

Buildings in *Seismic Design Category* E shall be designed to resist seismic loads in accordance with the *Building Code*, except where the *seismic design category* is reclassified to a ~~lower~~ *Seismic Design Category* D₂ in accordance with Section R301.2.2.1. Components of buildings not required to be designed to resist seismic loads shall be constructed in accordance with the provisions of this code.

R301.2.2.1.1 Alternate determination of seismic design category. ~~If soil conditions are determined by the building official to be Site Class A, B, or D, the seismic design category and short period design spectral response accelerations, S_{DS} , for a site shall be allowed to be determined in accordance with Figures R301.2.2.1.1(1) through R301.2.2.1.1(6), or Section 1613.2 of the *International Building Code*. The value of S_{DS} determined in accordance with Section 1613.2 of the *International Building Code* is permitted to be used to set the seismic design category in accordance with Table R301.2.2.1.1, and to interpolate between values in Tables R602.10.3(3) and R603.9.2(1) and other seismic design requirements of this code.~~

R301.2.2.2 Weights of materials. Average dead loads shall not exceed 15 pounds per square foot (720 Pa) for the combined roof and ceiling assemblies (on a horizontal projection) or ~~10-15~~ pounds per square foot (~~480-720~~ Pa) for floor assemblies, except as further limited by Section R301.2.2. Dead loads for walls above *grade* shall not exceed:

1. Fifteen pounds per square foot (720 Pa) for exterior light-frame wood walls.
2. Fourteen pounds per square foot (670 Pa) for exterior light-frame cold-formed steel walls.
3. Ten pounds per square foot (480 Pa) for interior light-frame wood walls.
4. Five pounds per square foot (240 Pa) for interior light-frame cold-formed steel walls.
5. Eighty pounds per square foot (3830 Pa) for 8-inch-thick (203 mm) masonry walls.
6. Eighty-five pounds per square foot (4070 Pa) for 6-inch-thick (152 mm) concrete walls.
7. Ten pounds per square foot (480 Pa) for SIP walls.

Exceptions:

1. Roof and ceiling dead loads greater than 15 pounds per square foot (720 Pa), but not exceeding 25 pounds per square foot (1190 Pa) shall be permitted provided that the wall bracing amounts in Section R602.10.3 are increased in accordance with Table R602.10.3(4).
2. Light-frame walls with stone or masonry veneer shall be permitted in accordance with the provisions of Sections R702.1 and R703.
3. Fireplaces and chimneys shall be permitted in accordance with Chapter 10.

IRC Figure R301.2.2.1(1) SDC—Alaska. ...*Not adopted.*

IRC Figure R301.2.2.1(2) SDC—Hawaii. ...*Not adopted.*

IRC Figure R301.2.2.1(3) SDC—Puerto Rico. ...*Not adopted.*

IRC Figure R301.2.2.1(4) SDC—Northern Mariana Islands... ...*Not adopted.*

IRC Figure R301.2.2.1(5) SDC—United States. ...*Not adopted.*

IRC Figure R301.2.2.1(6) SDC—United States. ...*Not adopted.*

IRC Figure R301.2.2.1.1(1) Alt. SDC—Alaska. ...*Not adopted.*

IRC Figure R301.2.2.1.1(2) Alt. SDC—Hawaii. ...*Not adopted.*

IRC Figure R301.2.2.1.1(3) Alt. SDC—Puerto Rico. ...*Not adopted.*

IRC Figure R301.2.2.1.1(4) Alt. SDC—Northern Mariana Islands ...*Not adopted.*

IRC Figure R301.2.2.1.1(5) Alternate Seismic Design Categories—United States. ...*Not adopted.*

IRC Figure R301.2.2.1.1(6) Alternate Seismic Design Categories—United States. ...*Not adopted.*

ORSC Figure R301.2.2.1: Seismic Design Categories have not changed from the 2021 ORSC.

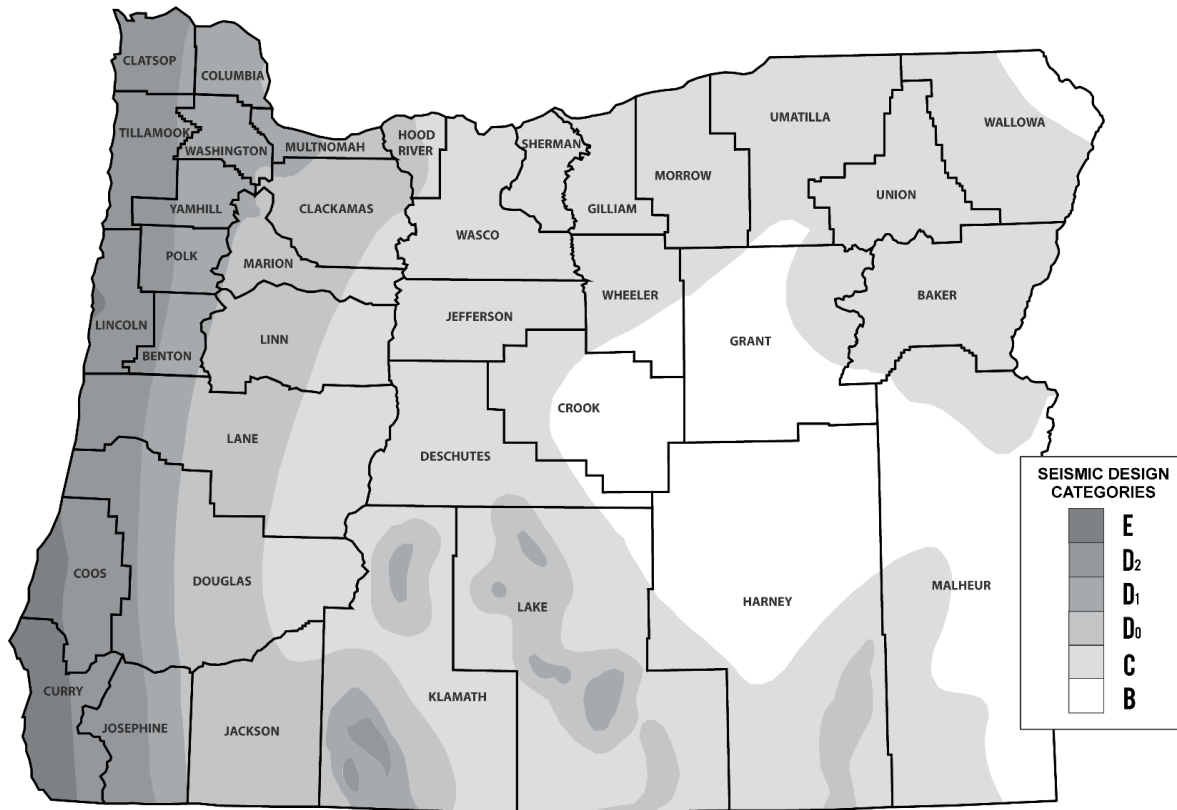

Note: Sites on the perimeter of identified seismic design categories shall be verified using the Applied Technology Council (ATC) hazards by location tool at <https://hazards.atcouncil.org> with the following selected information:

Reference document: ASCE 7-16

Risk category: II

Site class: D – Default

The reported value of the short-period design spectral acceleration, S_{DS} , shall be used in conjunction with Table R301.2.2.1.1 for determination of the seismic design category.

FIGURE R301.2.2.1
SEISMIC DESIGN CATEGORIES

Section R301.2.2.6 – Oregon adds figures to clarify the associated provisions. New amendments clarifying engineering requirements.

R301.2.2.6 Irregular buildings. The seismic provisions of this code shall not be used for structures, or portions thereof, located in *Seismic Design Categories* C, D₀, D₁ and D₂ and considered to be irregular in accordance with this section. A building or portion of a building shall be considered to be irregular where one or more of the conditions defined in Items 1 through 8 occur. Irregular structures, or irregular portions of structures, shall be designed in accordance with [Section R301.1.3](#) ~~accepted engineering practice~~ to the extent the irregular features affect the performance of the remaining structural system. Where the forces associated with the irregularity are resisted by a structural system designed in accordance with [Section R301.1.3](#), ~~accepted engineering practice~~, the remainder of the building shall be permitted to be designed using the [prescriptive](#) provisions of this code.

1. Shear wall or braced wall offsets out of plane.

Conditions where exterior *shear wall* lines or *braced wall panels* are not in one plane vertically from the foundation to the uppermost story in which they are required. [See Figure R301.2.2.6\(1\).](#)

Exception: For wood *light-frame construction*, floors with cantilevers or setbacks not exceeding four times the nominal depth of the wood floor joists [\[see Figure R301.2.2.6\(2\)\]](#) are permitted to support *braced wall panels* that are out of plane with *braced wall panels* below provided that all of the following are satisfied:

1. Floor joists are nominal 2 inches by 10 inches (51 mm by 254 mm) or larger and spaced not more than 16 inches (406 mm) on center.
2. The ratio of the back span to the cantilever is not less than 2 to 1.
3. Floor joists at ends of *braced wall panels* are doubled.
4. For wood-frame construction, a continuous rim joist is connected to ends of cantilever joists. Where spliced, the rim joists shall be spliced using a galvanized metal tie not less than 0.058 inch (1.5 mm) (16 gage) and 1½ inches (38 mm) wide fastened with six 16d nails on each side of the splice; or a block of the same size as the rim joist and of sufficient length to fit securely between the joist space at which the splice occurs, fastened with eight 16d nails on each side of the splice.
5. Gravity loads carried at the end of cantilevered joists are limited to uniform wall and roof loads and the reactions from headers having a span of 8 feet (2438 mm) or less.

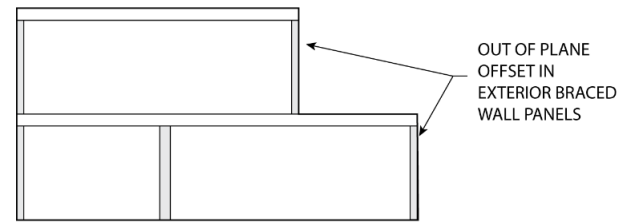

SECTION VIEW

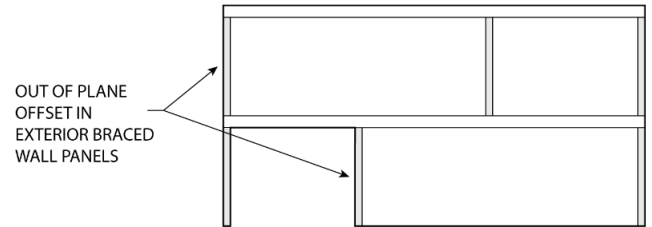

**FIGURE R301.2.2.6(1)
BRACED WALL PANELS OUT OF PLANE**

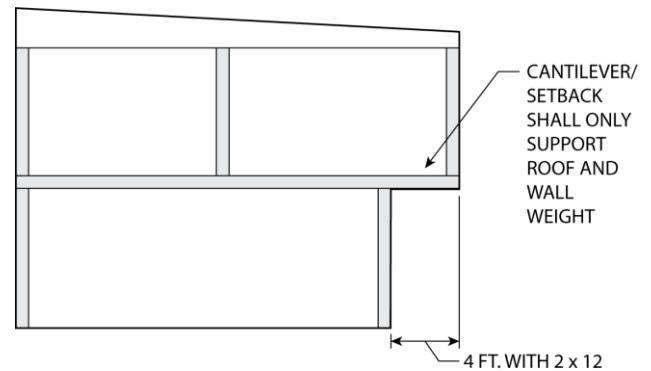

SECTION THRU CANTILEVER

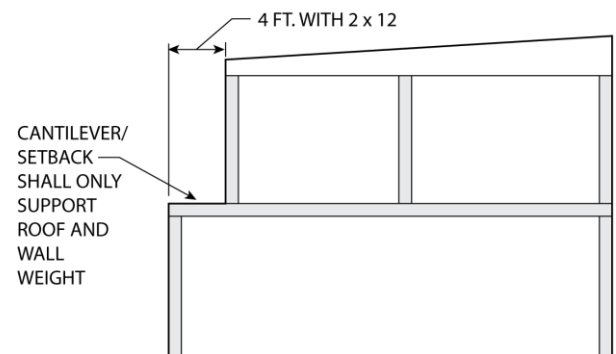

For SI: 1 foot = 304.8 mm.

**FIGURE R301.2.2.6(2)
BRACED WALL PANELS SUPPORTED BY
CANTILEVER OR SETBACK**

2. **Lateral support of roofs and floors.** Conditions where a section of floor or roof is not laterally supported by *shear walls* or *braced wall lines* on all edges. [See Figure R301.2.2.6\(3\).](#)

Exception: Portions of floors that do not support *shear walls*, *braced wall panels* above, or roofs shall be permitted to extend not more than 6 feet (1829 mm) beyond a *shear wall* or *braced wall line*. [See Figure R301.2.2.6\(4\).](#)

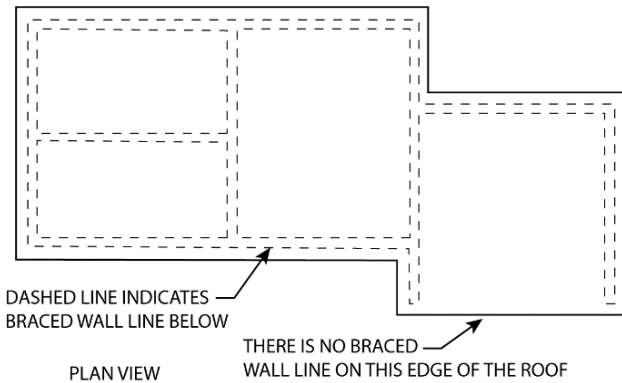

For SI: 1 foot = 304.8 mm.

FIGURE R301.2.2.6(3)
FLOOR OR ROOF NOT SUPPORTED AT ALL EDGES

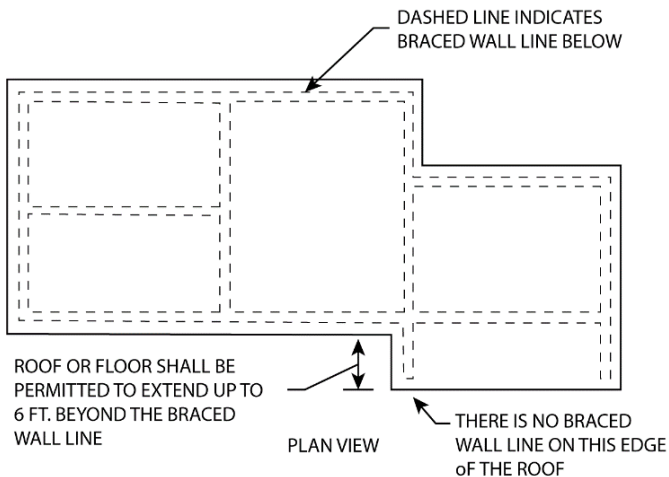

For SI: 1 foot = 304.8 mm.

FIGURE R301.2.2.6(4)
FLOOR OR ROOF EXTENSION BEYOND BRACED WALL LINE

3. **Shear wall or braced wall offsets in plane.** Conditions where the end of a *braced wall panel* occurs over an opening in the wall below and extends more than 1 foot (305 mm) horizontally past the edge of the opening. This provision is applicable to *shear walls* and *braced wall panels* offset in plane and to *braced wall panels* offset out of plane in accordance with the exception to Item 1. [See Figure R301.2.2.6\(5\).](#)

Exception: For wood light-frame wall construction, one end of a *braced wall panel* shall be permitted to extend more than 1 foot (305 mm) over an opening not more than 8 feet (2438 mm) in width in the wall below provided that the opening includes a header in accordance with all of the following:

1. The building width, loading condition and framing member species limitations of Table R602.7(1) shall apply.
2. The header is composed of:
 - 2.1. Not less than one 2×12 or two 2×10 for an opening not more than 4 feet (1219 mm) wide.
 - 2.2. Not less than two 2×12 or three 2×10 for an opening not more than 6 feet (1829 mm) in width.
 - 2.3. Not less than three 2×12 or four 2×10 for an opening not more than 8 feet (2438 mm) in width.
3. The entire length of the *braced wall panel* does not occur over an opening in the wall below.

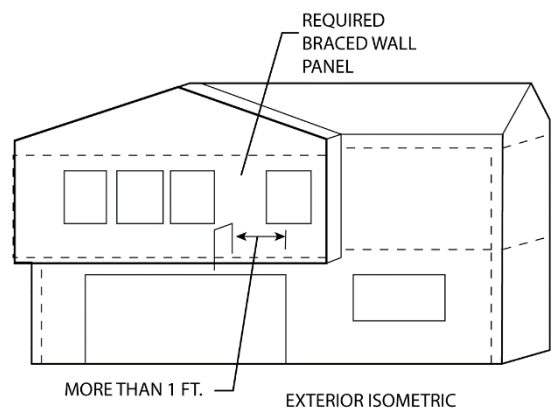
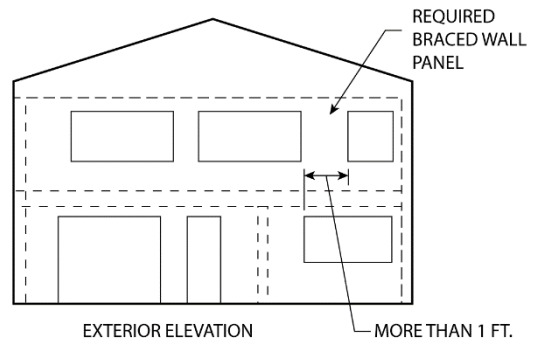

For SI: 1 foot = 304.8 mm.

FIGURE R301.2.2.6(5)
BRACED WALL PANEL EXTENSION OVER OPENING

4. **Floor and roof opening.** Conditions where an opening in a floor or roof exceeds the lesser of 12 feet (3658 mm) or 50 percent of the least floor or roof dimension between adjacent braced wall lines. See [Figure R301.2.2.6\(6\)](#).

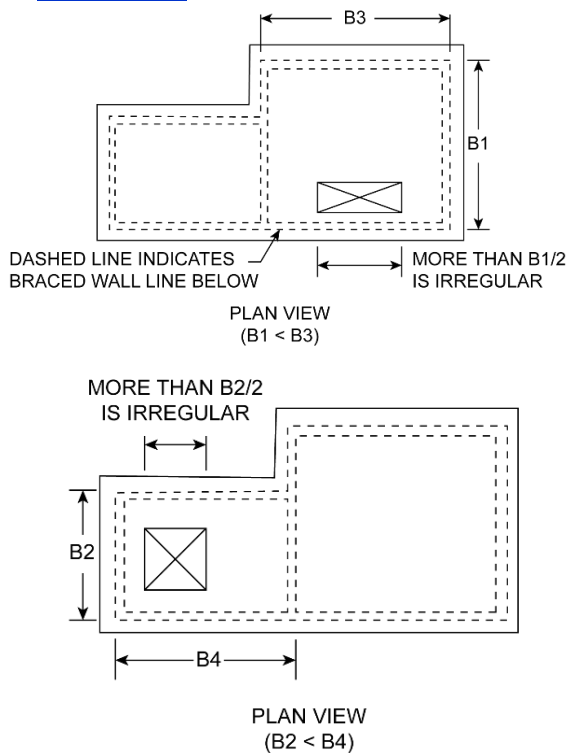

FIGURE R301.2.2.6(6)
OPENING LIMITATIONS FOR FLOOR AND ROOF DIAPHRAGMS

5. **Floor level offset.** Conditions where portions of a floor level are vertically offset.

Exceptions:

1. Framing supported directly by continuous foundations at the perimeter of the building.
2. For wood *light-frame construction*, floors shall be permitted to be vertically offset where the floor framing is lapped or tied together as required by Section R502.6.1. See [Figure R301.2.2.6\(7\)](#).

6. **Perpendicular shear wall and wall bracing.** Conditions where *shear walls* and *braced wall lines* do not occur in two perpendicular directions. See [Figure R301.2.2.6\(8\)](#).

7. **Wall bracing in stories containing masonry or concrete construction.** Conditions where stories above *grade plane* are partially or completely braced by wood wall framing in accordance with Section R602 or cold-formed steel wall framing in accordance with Section R603 include masonry or concrete wall construction. Where this irregularity applies, the entire story shall be designed in accordance with [Section R301.1.3](#) ~~accepted engineering practice~~.

Exceptions: Fireplaces, chimneys and masonry veneer in accordance with this code.

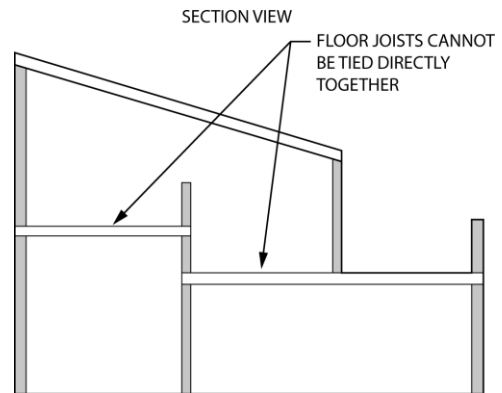
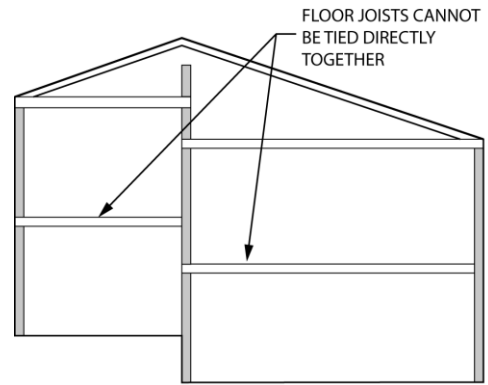

FIGURE R301.2.2.6(7)
PORTIONS OF FLOOR LEVEL OFFSET VERTICALLY

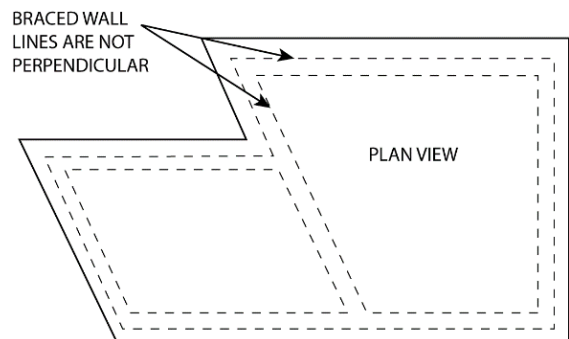

FIGURE R301.2.2.6(8)
BRACED WALL LINES NOT PERPENDICULAR

IRC R301.2.2.6 (#8)

8. **Hillside light-frame construction.** ...*Not adopted.*

New amendment

The new IRC irregularity trigger for hillside construction was not adopted.

R301.2.2.7 Height limitations. Wood-framed buildings shall be limited to three *stories* above *grade plane* or the limits given in Table R602.10.3(3). **Wood-framed buildings in *Seismic Design Category D₂* exceeding two *stories* shall be designed for wind and seismic loads in accordance with [Section R301.1.3](#) ~~accepted engineering practice~~.** Cold-formed steel-framed buildings shall be limited to less than or equal to three *stories* above *grade plane* in accordance with AISI S230. *Mezzanines* as defined in Section R202 that comply with Section R325 shall not be considered as *stories*. *Structural insulated panel* buildings shall be limited to two *stories* above *grade plane*.

Section R301.2.2.10 New amendment:

Section has been revised to refer to the Oregon Plumbing Specialty Code (OPSC) for seismic anchoring of water heater requirements.

R301.2.2.10 Anchorage of water heaters. [Water heaters shall be anchored or strapped to resist horizontal displacement due to earthquake motion in accordance with the *Plumbing Code*.](#)

~~In *Seismic Design Categories D₀*, *D₁* and *D₂*, and in townhouses in *Seismic Design Category C*, water heaters and thermal storage units shall be anchored against movement and overturning in accordance with [Section M1307.2](#) or [P2801.8](#).~~

2023 Oregon Plumbing Specialty Code provisions

507.2 Seismic Provisions. Water heaters shall be anchored or strapped to resist horizontal displacement due to earthquake motion. Strapping shall be at points within the upper one-third and lower one-third of its vertical dimensions. At the lower point, a distance of not less than 4 inches (102 mm) shall be maintained from the controls with the strapping.

Exception: Water heaters in one- and two-family dwellings and townhouses in Seismic Design Category B and C are not required to be strapped or anchored to resist horizontal displacement due to earthquake motion.

R301.2.3 Snow loads. Wood-framed construction, coldformed, steel-framed construction and masonry and concrete construction, and *structural insulated panel* construction in regions with ground snow loads 70 pounds per square foot (3.35 kPa) or less, shall be in accordance with Chapters 5, 6 and 8. Buildings in regions with ground snow loads greater than 70 pounds per square foot (3.35 kPa) shall be designed in accordance with [Section R301.1.3](#) ~~accepted engineering practice~~.

R301.2.3.1 Ground snow load determination. [Site-specific ground snow loads, \$p_g\$, shall be those set forth in the online lookup tool at \[Snowload.seao.org/lookup.html\]\(http://Snowload.seao.org/lookup.html\). Where the site elevation is higher than the modeled elevation reported by the online lookup tool, the reported *ground snow load* values shall be adjusted by adding the specified loads from \[Table R301.2.3.1\]\(#\). The minimum *ground snow load* for prescriptive design is 36 psf \(1.724 kN/m²\). The minimum roof snow load for *nonprescriptive design* is 25 psf \(1.197 kN/m²\), except where determined in accordance with Section 1608 of the *Building Code*.](#)

**TABLE R301.2.3.1
GROUND SNOW LOAD ADJUSTMENT**

<u>REGION</u>	<u>GROUND SNOW ADJUSTMENT LOADS (psf per foot of elevation gain)</u>
Oregon Coast Mountains	0.07
Interior and Willamette Valleys	0.04
Cascade Mountains	0.07
Siskiyou and Kalmiopsis Mountains	0.04
Plains east of the Cascades	0.007
Klamath Basin	0.008
Eastern Oregon Mountains	0.04

[For SI: 1 pound per square foot = 0.0479 kPa.](#)

R301.2.4 Floodplain construction. Buildings and structures constructed in whole or in part in flood hazard areas (including A or V Zones), as established ~~by the flood plain administrator in [Table R301.2](#)~~, and substantial improvement and repair of substantial damage of buildings and structures in flood hazard areas, shall be designed and constructed in accordance with Section R322. Buildings and structures that are located in more than one flood hazard area shall comply with the provisions associated with the most restrictive flood hazard area. Buildings and structures located in whole or in part in identified floodways, [as established by the flood plain administrator](#), shall be designed and constructed in accordance with ASCE 24.

IRC R301.2.4.1 Alternative provisions. *...Not adopted.*

Section R301.3 – Model code change:

This change increased the story height limit for wood wall framing where specific exception requirements are met.

R301.3 Story height. The wind and seismic provisions of this code shall apply to buildings with *story heights* not exceeding the following:

1. For wood wall framing, the *story height* shall not exceed 11 feet 7 inches (3531 mm) and the laterally unsupported bearing wall stud height ~~permitted by~~ shall be in accordance with Table R602.3(5).

Exception: A *story height* not exceeding 13 feet 7 inches (4140 mm) is permitted provided that, the maximum wall stud clear height does not exceed 12 feet (3658 mm), the wall studs are in accordance with Exception 2 or 3 of Section R602.3.1 or ~~an engineered~~ a nonprescriptive design is provided for the wall framing members, and wall bracing for the building is in accordance with Section R602.10. Studs shall be laterally supported at the top and bottom plate in accordance with Section R602.3.

[Items 2 through 5 remain unchanged]

For walls other than wood-framed walls, individual walls or wall studs shall be permitted to exceed these limits as permitted by Chapter 6 provisions, provided that the *story heights* of this section are not exceeded. ~~An engineered design~~ A nonprescriptive design shall be provided for the wall or wall framing members where the limits of Chapter 6 are exceeded. Where the *story height* limits of this section are exceeded, the design of the building, or the noncompliant portions thereof, to resist wind and seismic loads shall be in accordance with the *Building Code*.

R301.5 Live load. The minimum ~~uniformly distributed~~ live loads shall be as provided in Table R301.5.

TABLE R301.5
MINIMUM UNIFORMLY DISTRIBUTED LIVE LOADS (in pounds per square foot)

USE	UNIFORM LOAD (psf)	CONCENTRATED LOAD (lb)
Uninhabitable attics without storage ^b	10	—
Uninhabitable attics with limited storage ^{b, g}	20	—
Habitable attics and attics served with fixed stairs	30	—
Balconies (exterior) and decks ^c	40	—
Fire escapes	40	—
Guards	—	200 ^{h,i}
Guard in-fill components ^f	—	50 ^h
Handrail ^d	—	200 ^h
Passenger vehicle garages	50	2,000 ^a
Areas other than sleeping areas	40	—
Sleeping areas	30	—
Stairs	40 ^c	300 ^c

For SI: 1 inch = 25.4 mm, 1 pound per square foot = 0.0479 kPa, 1 square inch = 645 mm², 1 pound = 4.45 N.

~~a. — Elevated garage floors shall be capable of supporting the uniformly distributed live load or a 2,000-pound concentrated load applied on an area of 4½-inches by 4½-inches, whichever produces the greater stresses.~~

a. Independent of the 50 psf uniform load case, elevated garage floors shall also be capable of supporting two 2,000-pound loads each applied over 4.5-inch by 4.5-inch areas centered 5 feet apart perpendicular to the direction of vehicle entry and a second pair of 2,000-pound loads 9 feet from the first pair of 2,000-pound loads parallel to the direction of vehicle entry. This combination of concentrated loads shall be applied where they cause the maximum bending moment and deflection, and separately where they cause the maximum shear and bearing stress of the supporting framing members, but need not be applied closer than 2 feet from the interior end wall nor closer than 1 foot from interior sidewalls.

[The rest of the footnotes remain unchanged.]

TABLE R301.7
ALLOWABLE DEFLECTION OF STRUCTURAL MEMBERS^{b, c}

[The contents of the table remain unchanged.]

Note: *L* = span length, *H* = span height.

- a. For the purpose of the determining deflection limits herein, the wind load shall be permitted to be taken as 0.7 times the component and cladding (ASD) loads obtained from Table R301.2.1(1).
- b. For cantilever members, *L* shall be taken as twice the length of the cantilever.
- c. For aluminum structural members or panels used in roofs or walls of sunroom additions, or deck, patio or porch covers, not supporting edge of glass or sandwich panels, the total load deflection shall not exceed *L*/60. For continuous aluminum structural members supporting edge of glass, the total load deflection shall not exceed *L*/175 for each glass lite or *L*/60 for the entire length of the member, whichever is more stringent. For sandwich panels used in roofs or walls of sunroom additions, or deck, patio or porch covers, the total load deflection shall not exceed *L*/120.
- d. Deflection for exterior walls with interior gypsum board finish shall be limited to an allowable deflection of *H*/180.
- e. Refer to Section R703.8.2. The dead load of supported materials shall be included when calculating the deflection of these members.

SECTION R302 FIRE-RESISTANT CONSTRUCTION

R302.1 Exterior walls. Construction, projections, openings and penetrations of *exterior walls* of *dwelling*s and *accessory structures* ~~accessory buildings~~ shall comply with Table R302.1(1); ~~or dwellings equipped throughout with an automatic sprinkler system installed in accordance with Section P2904 shall comply with Table R302.1(2).~~ Where multiple detached dwellings are located on a single lot, each detached dwelling shall comply independently with Table R302.1.

Exceptions:

1. Walls, projections, openings or penetrations in walls perpendicular to the line used to determine the *fire separation distance*.
2. Walls of *individual dwelling units* and their *accessory structures* located on the same *lot*.
3. Detached *nonhabitable accessory structures* ~~tool sheds and storage sheds, playhouses and similar structures~~ exempted from *permits* are not required to provide wall protection based on location on the *lot*. Projections beyond the exterior wall shall not extend over the *lot line*.
4. Detached garages accessory to a *dwelling* located within 2 feet (610 mm) of a *lot line* are permitted to have roof eave projections not exceeding 4 inches (102 mm).
5. Foundation vents installed in compliance with this code are permitted.
6. Attached decks that are exempt from permits by Section R105.2. All other attached decks shall be considered projections for compliance with Table R302.1.

TABLE R302.1(1)
EXTERIOR WALLS

EXTERIOR WALL ELEMENT		MINIMUM FIRE-RESISTANCE RATING	MINIMUM FIRE SEPARATION DISTANCE PROVIDED
Walls	Fire-resistance rated	1 hour—tested in accordance with ASTM E119, UL 263 or Section 703.3 of the International Building Code with exposure from both sides	< 3 0 feet
	Not fire-resistance rated	0 hours	≥ 3 5 feet
Projections	Not allowed	N/A	< 2 feet
	Fire-resistance rated	1 hour on the underside, or heavy timber, or fire-retardant-treated wood ^{a, b}	≥ 2 feet to < 3 5 feet
	Not fire-resistance rated	0 hours	≥ 3 5 feet
Openings in walls	Not allowed	N/A	< 3 feet
	25% maximum of wall area	0 hours	3 feet
	Unlimited	0 hours	≥ 3 5 feet
Penetrations	All	Comply with Section R302.4	< 3 feet
		None required	≥ 3 feet

For SI: 1 foot = 304.8 mm. NA = Not Applicable.

- a. The fire-resistance rating shall be permitted to be reduced to 0 hours on the underside of the eave overhang if fireblocking is provided from the wall top plate to the underside of the roof sheathing. Fireblocking shall consist of not less than two layers of two-inch nominal lumber.
- b. The fire-resistance rating shall be permitted to be reduced to 0 hours on the underside of the rake overhang where gable vent openings are not installed.
- c. For the purposes of this table, attached decks that are not exempted by Section R105.2 shall be considered projections.

IRC Table R302.1(2) Exterior Walls—Dwellings with Fire Sprinklers. ...Not adopted.

R302.2 Townhouses. Each townhouse shall be considered a separate building and shall adjoin or have access to a yard, street, alley or public way on not less than two sides. The centerline of an adjoining public way shall be considered an adjacent lot line. Walls separating Each townhouse units shall be constructed in accordance with Sections R302.2.1 through R302.2.14 or R302.2.2 and shall comply with Sections 302.2.3 through 302.2.5.

IRC R302.2.1 Double walls. *...Not adopted.*

IRC R302.2.2 Common walls. *...Not adopted.*

R302.2.1 Townhouse separation wall assemblies. Townhouses shall be separated by 2-hour fire-resistance-rated wall assemblies in accordance with one of the following requirements:

1. Two 1-hour fire-resistance-rated firewalls, one on each side of the common lot line as shown in Figures R302.2.1(1) and R302.2.1(2).
2. A common “modified” 2-hour fire-resistance-rated firewall centered over the common lot line as shown in Figures R302.2.1(3) and R302.2.1(4). Plumbing or mechanical equipment ducts or vents are not permitted in the cavity of the “modified” 2-hour wall, except as specifically detailed in Section R302.4.2.1. Electrical installations shall be installed in accordance with the *Electrical Code*. Penetrations of electrical outlet boxes shall be in accordance with Section R302.4.
3. A common 2-hour fire-resistance-rated wall. Plumbing or mechanical equipment ducts or vents are not permitted in the cavity of the common 2-hour fire-resistance-rated wall. Electrical installations shall be installed in accordance with the *Electrical Code*. Penetrations of electrical outlet boxes shall be in accordance with Section R302.4.

Exception: A common 2-hour fire-resistance-rated wall is not permitted in townhouses that are separated by a real lot line.

4. Listed and tested assemblies that provide an equivalent fire-resistance rating in accordance with ASTM E119, UL 263 or Section 703.2.2 of the *Building Code*.

Exception: Privacy walls may be constructed of heavy timber construction.

R302.2.1.1 Sprinkler protection. Townhouse separation wall assemblies shall be permitted to be reduced to 1-hour fire-resistance-rated wall assemblies where an automatic fire sprinkler system is installed in accordance with NFPA 13D.

R302.2.2 Mixed occupancies. Mixed occupancies are not permitted in townhouses. Such buildings shall be designed and constructed in accordance with the requirements set forth for mixed occupancies or live/work units in the *Building Code*.

Exception: Private garages and carports attached to townhouses and totaling not more than 1,000 square feet (92.9 m²) in area per individual townhouse.

R302.2.3 Utilities for townhouses. Shared or common-use utilities shall not run beneath a townhouse. Separate utility services shall be supplied to each individual townhouse. Utilities serving an individual townhouse shall not run beneath another separate townhouse and shall not run through the attic of another separate townhouse.

R302.2.4 ~~R302.2.3~~ Fire-resistance-rated continuity. The fire-resistance-rated wall or assembly separating townhouses shall be continuous from the foundation to the underside of the roof sheathing, deck or slab. The fire-resistance rating shall extend the full length of the wall or assembly, including wall extensions through and separating attached enclosed accessory structures. The fire-resistance-rated walls shall be in accordance with the following:

1. Exterior walls and common townhouse separation walls shall be continuous from the foundation to the underside of the roof sheathing where the roof/ceiling assembly is constructed in accordance with Section R302.2.6.1. The common townhouse separation wall shall extend to completely separate adjacent townhouses and any attached accessory structures.
2. Privacy walls separating porches and decks without a cover shall be continuous from the foundation to the top of the guard and have a height of not less than 3 feet (914 mm) above the porch or deck finish floor elevation. The privacy wall shall extend to the farthest point of the porch or deck.
3. Privacy walls separating porch and deck coverings shall be continuous from the foundation to the underside of the roof sheathing where the roof/ceiling assembly is constructed in accordance with Section R302.2.6.1. The privacy wall shall extend to the farthest point of the porch covering.
4. Fire-resistance-rated gypsum wallboard used in exterior walls, privacy walls and common townhouse separation walls shall be continuous behind building elements such as showers, bathtubs, cabinets, chases, soffits, electrical panels and stair stringers.

Exception: Gypsum board may be omitted behind stair stringers, provided that the stringers are constructed of one of the following:

1. Solid sawn dimensional lumber of not less than 3 inches (76 mm) nominal thickness where used in conjunction with two 1-hour fire-resistance-rated wall assemblies as shown in Figure R302.2.4 (Detail A).
2. Solid sawn dimensional lumber of not less than 4.5 inches (114 mm) nominal thickness where used in conjunction with a 2-hour fire-resistance-rated wall assembly as shown in Figure R302.2.4 (Detail B).
3. Engineered wood systems that have been tested and listed for equivalent burning characteristics.

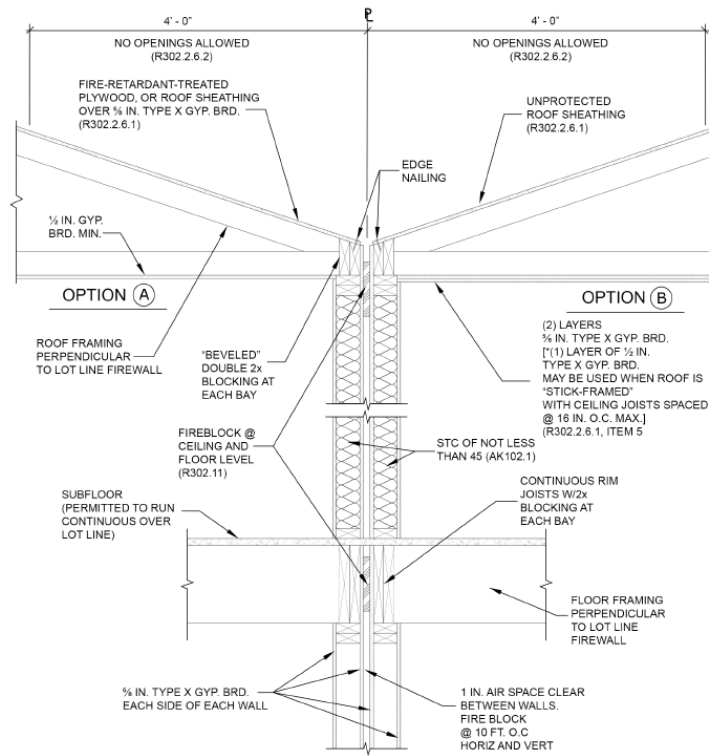

For SI: 1 inch = 25.4 mm.

a. . . . Where not otherwise indicated, wall assembly details shall be in accordance with ASTM E119, UL 263 or Section 703.3 of the Building Code.

FIGURE R302.2.1(1)
TWO 1-HOUR FIREWALLS PERPENDICULAR TO COMMON LOT LINE^a

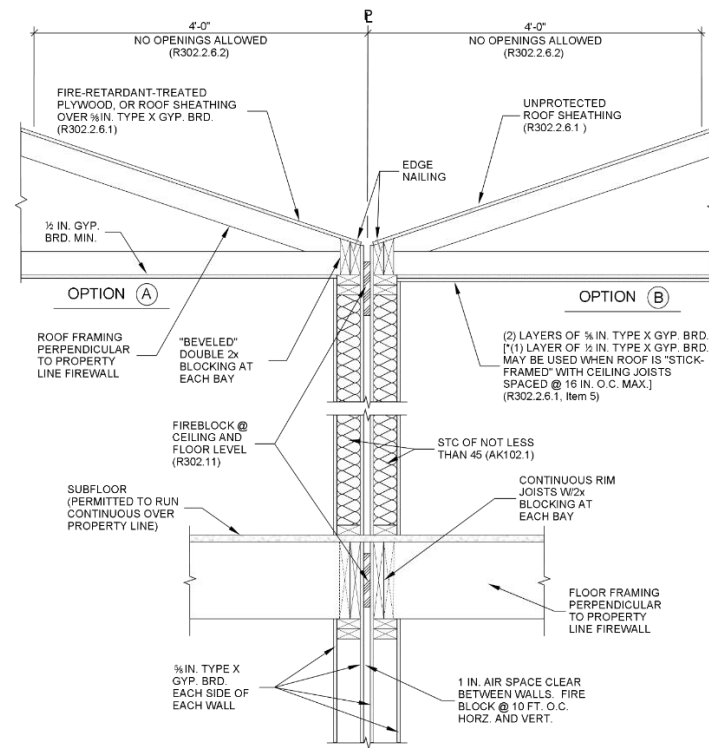

For SI: 1 inch = 25.4 mm.

a. . . . Where not otherwise indicated, wall assembly details shall be in accordance with ASTM E119, UL 263 or Section 703.3 of the Building Code.

FIGURE R302.2.1(1)
TWO 1-HOUR FIREWALLS PERPENDICULAR TO COMMON LOT LINE^a

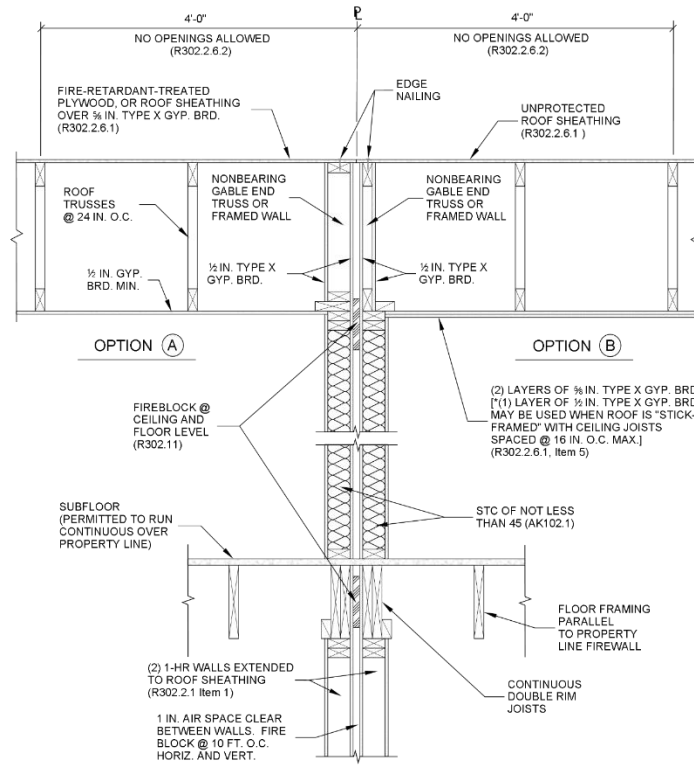

For SI: 1 inch = 25.4 mm.

a. Where not otherwise indicated, wall assembly details shall be in accordance with ASTM E119, UL 263 or Section 703.3 of the Building Code.

FIGURE R302.2.1(2)
TWO 1-HOUR FIREWALL PARALLEL TO COMMON LOT LINE³

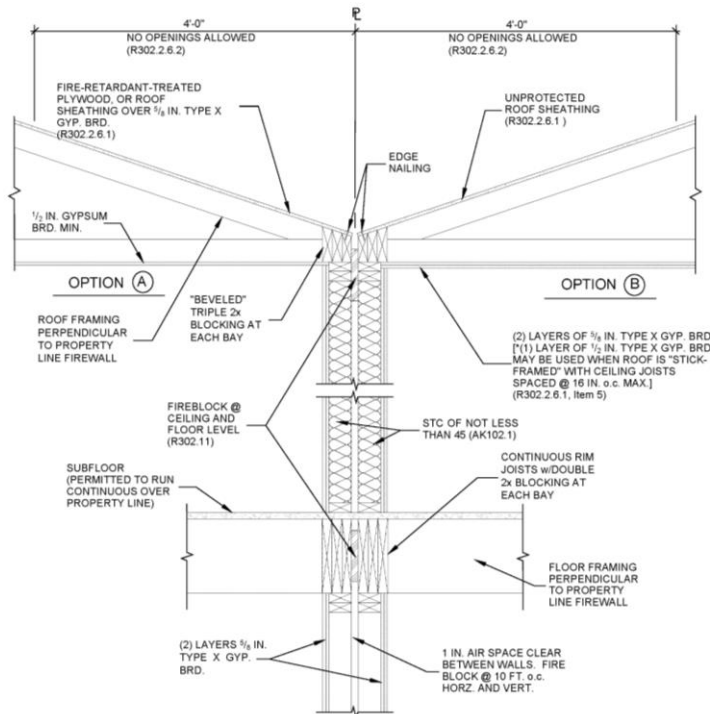

For SI: 1 inch = 25.4 mm.

a. Where not otherwise indicated, wall assembly details shall be in accordance with ASTM E119, UL 263 or Section 703.3 of the Building Code.

FIGURE R302.2.1(3)
"MODIFIED" 2-HOUR FIREWALL PERPENDICULAR TO COMMON LOT LINE³

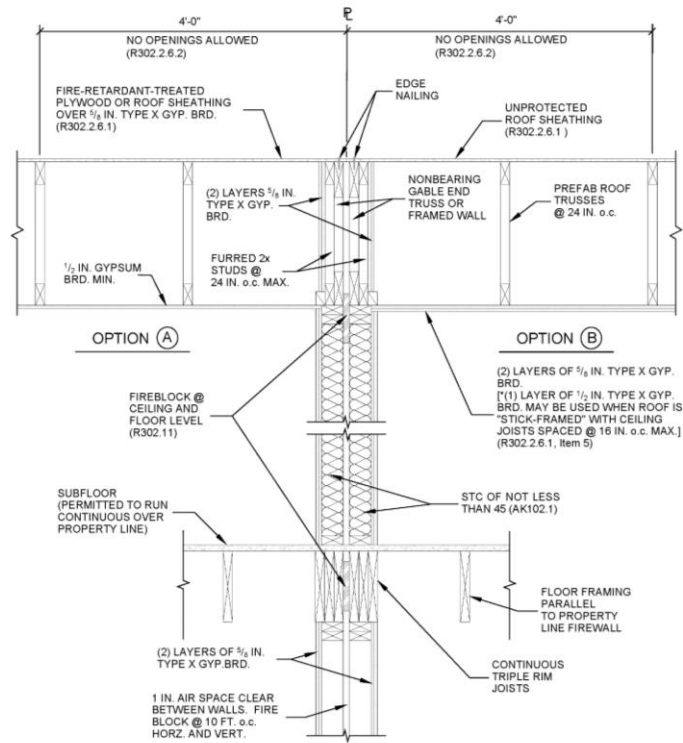

For SI: 1 inch = 25.4 mm.

a. Where not otherwise indicated, wall assembly details shall be in accordance with ASTM E119, UL 263 or Section 703.3 of the Building Code.

FIGURE R302.2.1(4)
"MODIFIED" 2-HOUR FIREWALL PARALLEL TO COMMON LOT LINE^a

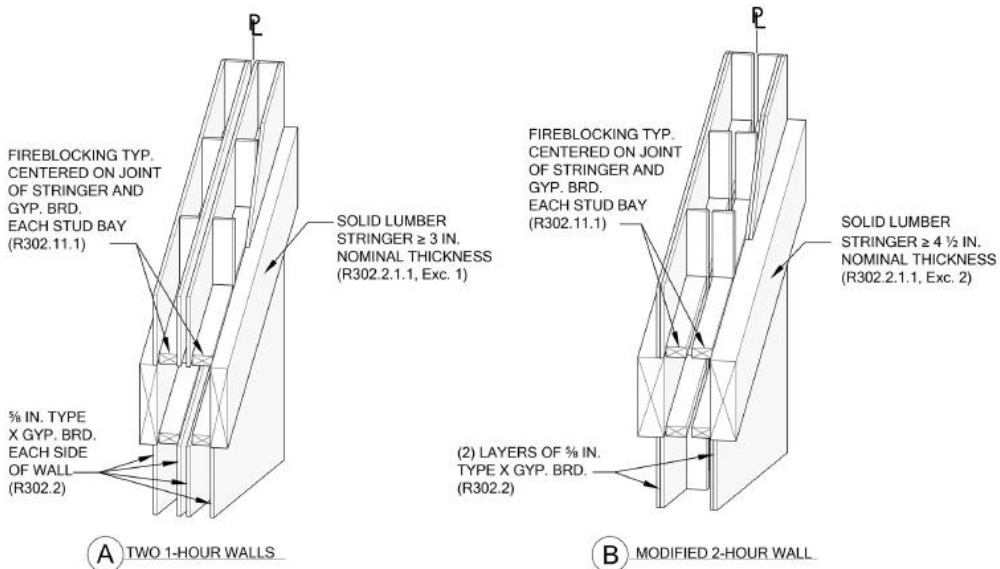

For SI: 1 inch = 25.4 mm.

FIGURE R302.2.4
STRINGER PENETRATIONS OF FIREWALL AT COMMON LOT LINE

R302.2.4.1 Porches and decks without a cover. Fire-resistance-rated protection shall be provided for porches and decks without a cover in accordance with the following methods:

1. Where one porch or deck is adjacent to another porch or deck, and both are less than 3 feet (914 mm) from a common *lot line*, a single 1-hour fire-resistance-rated privacy wall shall be provided for each porch or deck. The privacy wall shall extend to the farthest point where the porches or decks are adjacent.
2. Where one porch or deck abuts another adjacent porch or deck at a common *lot line*, either two 1-hour fire-resistance-rated walls or one “modified” 2-hour fire-resistance-rated common *townhouse* separation wall shall be provided. The *townhouse* separation wall shall extend to the farthest point where the porches or decks are adjacent.
3. Where a porch or deck is less than 3 feet (914 mm) from a common *lot line* and there is no adjacent porch or deck less than 3 feet (914 mm) from the common *lot line*, the porch or deck shall be of either noncombustible or heavy timber construction (see Figure R302.2.4).

Heavy timber porch components supporting only the dead load of the porch or deck and the *live load* listed in Table R301.5 shall be constructed in accordance with the following:

- 3.1. Supporting posts for porches and decks shall be not less than 6 inches (152 mm) in nominal thickness.
- 3.2. Joists or beams supporting porches and decks shall be not less than 4 inches (102 mm) in nominal thickness.
- 3.3. Decking on porches and decks shall be not less than 2 inches (51 mm) in nominal thickness.

Porches and decks that extend beyond the privacy wall on only one side need not be protected past the privacy wall unless they are less than 3 feet (914 mm) from a common *lot line*.

Exception: Porches and decks without a cover and located less than 3 feet (914 mm) from a common *lot line* need not be fire-resistance rated where the finished floor of the deck or porch is less than 30 inches (762 mm) above *grade*.

R302.2.4.2 Porch covers. Fire-resistance-rated protection shall be provided for porch covers in accordance with the following:

1. Where one porch cover is adjacent to another porch cover and both are less than 3 feet (914 mm) from the common *lot line*, a single 1-hour fire-resistance-rated privacy wall shall be provided for each porch cover. The privacy wall shall extend out to the farthest point where the porch covers are adjacent.
2. Where one porch cover abuts another adjacent porch

cover at a common *lot line*, either two 1-hour fire-resistance-rated walls or one “modified” 2-hour fire-resistance-rated common *townhouse* separation wall shall be provided. The *townhouse* separation wall or two individual walls shall extend out to the farthest point where both porch covers are adjacent. Abutting porch covers attached to structurally independent or dependent *townhouses* may share building elements as permitted by Section R302.2.7.

3. Where a porch cover is less than 3 feet (914 mm) from the common *lot line* and there is no adjacent porch cover, a 1-hour fire-resistance-rated *exterior wall* shall be provided. The *exterior wall* shall extend to the farthest point of the porch cover.

The fire-resistance-rated walls required in Items 1 through 3 shall be continuous from the foundation to the roof sheathing where the roof/ceiling assembly is constructed in accordance with Section R302.2.6.1. Where the roof/ceiling assembly is not constructed in accordance with Section R302.2.6.1, the walls shall terminate in a parapet constructed in accordance with Section R302.2.5. Porch covers separated by a fire-resistance-rated privacy or *dwelling unit* separation wall need not be fire-resistance rated.

Exceptions:

1. A privacy wall need not protect porch covers and the porch covers need not be fire-resistance rated where each individual *townhouse* is provided with an automatic fire sprinkler system in accordance with NFPA 13D. Porch covers are permitted to be of open construction or fully enclosed where ceilings are not less than 1-hour fire-resistance-rated construction.
2. A privacy wall need not protect a porch cover where the cover is constructed entirely of heavy timber construction. The heavy timber porch cover shall be open construction unless enclosed at the ceiling by not less than 1-hour fire-resistance-rated construction. Heavy timber porch cover components shall be provided according to the following:
 - 2.1. Supporting post for porch coverings shall be not less than 6 inches (152 mm) in nominal thickness.
 - 2.2. Joists or beams supporting porch coverings shall be not less than 4 inches (102 mm) in nominal thickness.
 - 2.3. Roof sheathing shall be not less than 2 inches (51 mm) in nominal thickness.

3. A privacy wall need not protect porch covers and the porch covers need not be of fire-resistance rated construction where they project not more than 2 feet (610 mm) from the face of the building.

4. A privacy wall need not protect porch covers and the porch covers need not be of fire-resistance rated construction where:

4.1. The exterior wall of the building perpendicular to the common lot line is 1-hour fire-resistance-rated construction for a distance of not less than 4 feet (1219 mm) on each side of the common lot line and there are no openings from the foundation to the underside of the porch roof sheathing. Where individual townhouses are stepped, no openings shall be allowed in the foundation less than 4 feet (1219 mm) from the lot line.

4.2. A porch cover projects less than 4 feet (1219 mm) from the face of the building. The adjacent building walls and porch roof may be protected for a distance equal to the distance the porch cover projects.

4.3. The porch cover is of open-frame construction. When fully enclosed, the ceiling shall be of not less than 1-hour fire-resistance-rated construction (see Figure R302.2.4.2). Enclosed attic space shall be separated at the common lot line with either two 1-hour separation walls or one common "modified" 2-hour townhouse separation wall.

The parapet may be omitted on both open-framed and enclosed porch covers where the roof is sheathed with fire-retardant-treated plywood or 5/8-inch (15.9 mm) Type X gypsum sheathing for a horizontal distance of not less than 4 feet (1219 mm) measured perpendicularly to the common lot line.

R302.2.4.3 Exterior stairways. Exterior stairs located less than 3 feet (914 mm) from a common lot line shall be of fire-resistance-rated construction in accordance with the following (see Figure R302.2.4.3):

1. Structurally independent stairs may be connected at the common lot line with common treads not less than 6 feet (1829 mm) in width of noncombustible or heavy timber construction.

2. Stairs serving an uncovered porch that serves not more than two individual townhouses may cross the common lot line. Such stairs shall be not less than 44 inches (1118 mm) in width and shall be of noncombustible or heavy timber construction.

3. Stairs constructed using heavy timbers shall comply with this section and Figure R302.2.4.3. Heavy timber stair components supporting only the stair or landing dead load and the live load listed in Table R301.5 shall be constructed using the following minimum material thicknesses:

3.1. Supporting posts for stairs shall be not less than 6 inches (152 mm) in nominal thickness.

3.2. Stair stringers shall be not less than 4 inches (102 mm) in nominal thickness.

3.3. Joists or beams supporting landings shall be not less than 4 inches (102 mm) in nominal thickness.

3.4. Stair treads and landing decking shall be not less than 6 inches (152 mm) in nominal thickness.

Exceptions:

1. Stairs located less than 3 feet (914 mm) from a common lot line need not be fire-resistance rated where they are not under cover and not more than 30 inches (762 mm) above grade.

2. Stairs may be located less than 3 feet (914 mm) from a common lot line where constructed using noncombustible materials.

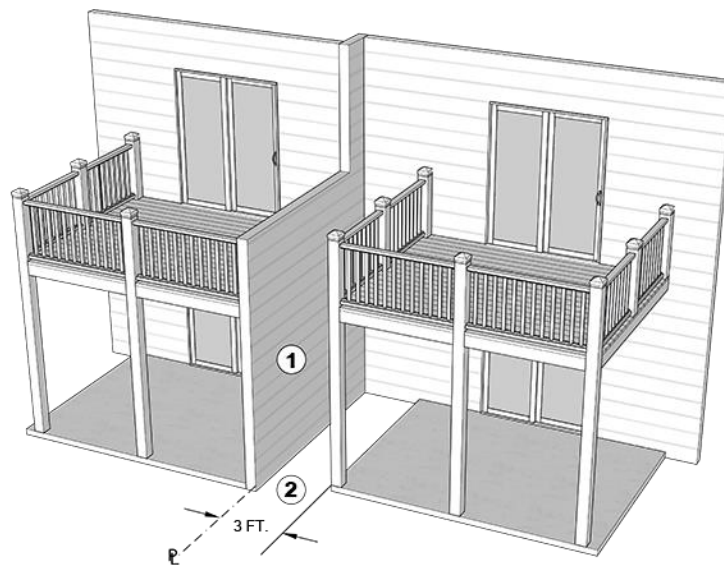

For SI: 1 inch = 25.4 mm, 1 foot = 304.8 mm.

Notes:

1. Decks located less than 3 feet from a lot line shall be protected at the lot line with 1-hour fire-resistance-rated walls that extend from grade level to not less than 36 inches above the deck or the height of the guardrail, whichever is greater.
2. Decks located 3 feet or more from the property line may be of nonfire-resistance-rated construction. Decks located less than 3 feet from the property line shall be of noncombustible or modified heavy timber construction.

**FIGURE R302.2.4.1
DECK CONSTRUCTION LESS THAN 3 FEET FROM COMMON LOT LINES**

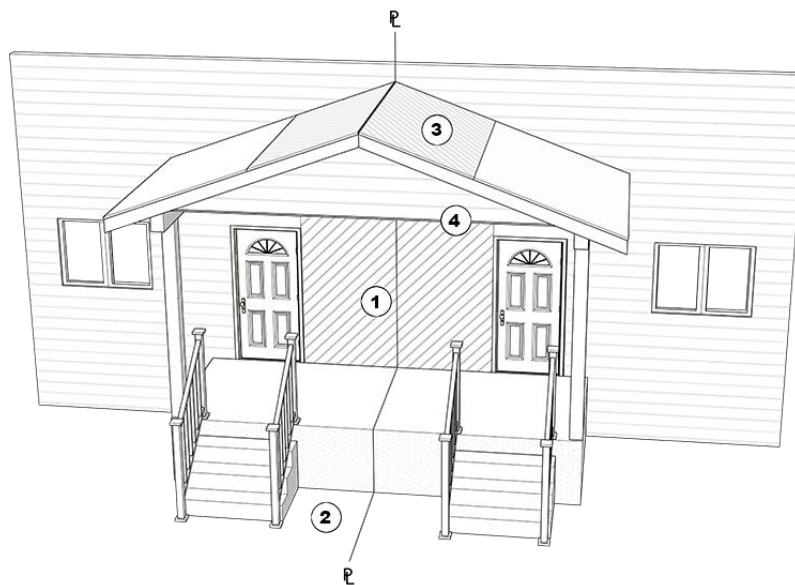

For SI: 1 inch = 25.4 mm, 1 foot = 304.8 mm.

Notes:

1. One-hour fire-resistance-rated wall, without openings, continuing from the common lot line and extending not less than 4 feet measured perpendicularly to the lot line, across the front of the dwelling unit. This wall is to extend from the foundation of the dwelling unit to the uppermost roof sheathing of the porch.
2. Stairs less than 3 feet from the lot line shall be of 1-hour fire-resistance-rated, modified heavy timber or noncombustible construction. See Figure R302.2.4.3.
3. Roof construction shall be that for the lot line construction.
4. Where a porch soffit is provided, the soffit shall be of 5/8-inch Type X gypsum sheathing, without openings, for its full depth and width.

**FIGURE R302.2.4.2
COVERED PORCH AT COMMON LOT LINE**

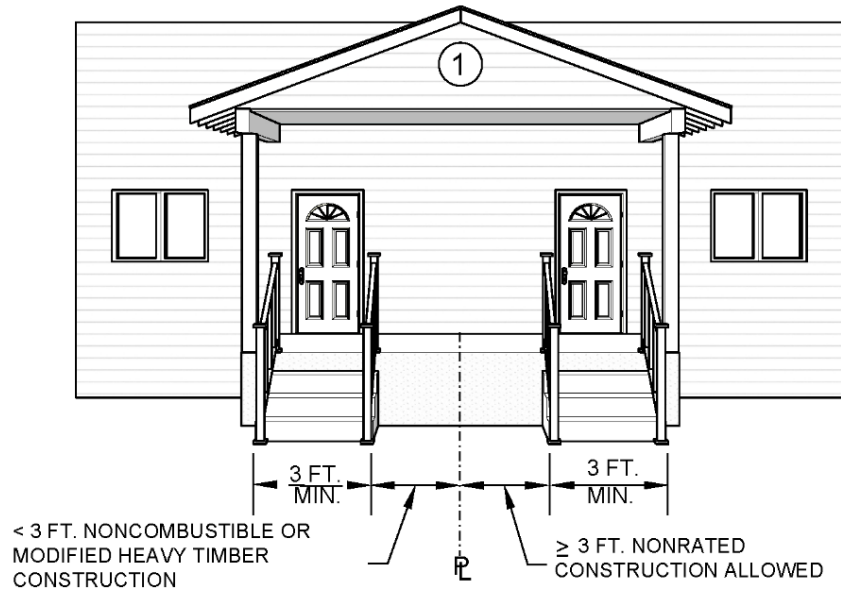

OPTION A

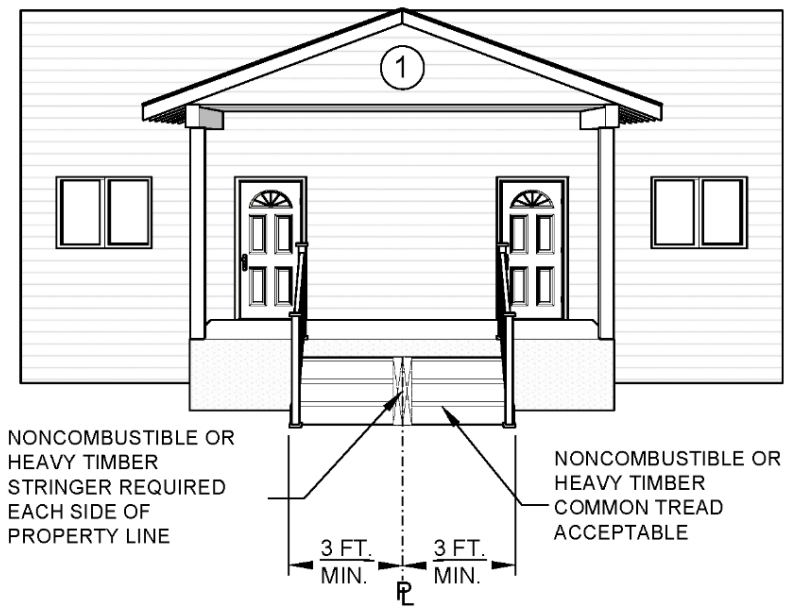

OPTION B

For SI: 1 inch = 25.4 mm.

Notes:

1. For uncovered porches serving not more than two units, a common stair may be provided with a width of not less than 44 inches and shall be of noncombustible or heavy timber construction.

**FIGURE R302.2.4.3
EXTERIOR STAIRWAY**

R302.2.5 ~~R302.2.4~~ **Parapets for townhouses.** Where required, parapets constructed in accordance with Section R302.2.5 shall be constructed for townhouses as an extension of exterior walls or common walls separating townhouse units in accordance with the following:

1. Where roof surfaces adjacent to the wall or walls are at the same elevation, the parapet shall extend not less than 30 inches (762 mm) above the roof surfaces.
2. Where roof surfaces adjacent to the wall or walls are at different elevations and the higher roof is not more than 30 inches (762 mm) above the lower roof, the parapet shall extend not less than 30 inches (762 mm) above the lower roof surface.

Exception: A parapet is not required in the preceding two cases where the roof covering complies with a minimum Class C rating as tested in accordance with ASTM E108 or UL 790 and the roof decking or sheathing is of *noncombustible materials* or fire-retardant-treated wood for a distance of 4 feet (1219 mm) on each side of the wall or walls, or one layer of $\frac{5}{8}$ -inch (15.9 mm) Type X gypsum board is installed directly beneath the roof decking or sheathing, supported by not less than nominal 2-inch (51 mm) ledgers attached to the sides of the roof framing members, for a distance of not less than 4 feet (1219 mm) on each side of the wall or walls and any openings or penetrations in the roof are not within 4 feet (1219 mm) of the common walls. Fire-retardant-treated wood shall meet the requirements of Sections R802.1.5 and R803.2.1.2. Fire-retardant-treated wood shall meet the requirements of Sections R802.1.5 and R803.2.1.2.

3. A parapet is not required where roof surfaces adjacent to the wall or walls are at different elevations and the higher roof is more than 30 inches (762 mm) above the lower roof. The common wall construction from the lower roof to the underside of the higher *roof deck* shall have not less than a 1-hour fire-resistance rating. The wall shall be rated for exposure from both sides. A parapet is not required for roofs that comply with Section R302.2.6.

R302.2.5.1 ~~R302.2.5~~ **Parapet construction.** Parapets shall have the same fire-resistance rating as that required for the supporting wall or walls. On any side adjacent to a roof surface, the parapet shall have noncombustible faces for the uppermost 18 inches (457 mm), to include counterflashing and coping materials. Where the roof slopes toward a parapet at slopes greater than 2 units vertical in 12 units horizontal (16.7-percent slope), the parapet shall extend to the same height as any portion of the roof within a distance of 3 feet (914 mm), and the height shall be not less than 30 inches (762 mm).

R302.2.6 **Townhouse roof construction.** In addition to the requirements of Chapter 8 of this code, townhouses shall comply with this section for fire-resistance-rated roof/ceiling construction, roof/ceiling penetrations and cricket construction. Projections of eaves, cornices and similar components shall comply with Section R302.2.6.4.

R302.2.6.1 **Roof/ceiling assemblies.** Roof/ceiling assemblies intersecting fire-resistance-rated exterior walls may be of nonfire-resistance-rated construction. Roof/ceiling assemblies intersecting common fire-resistance-rated individual townhouse unit separation walls and privacy walls associated with porch covers and decks shall comply with Section R302.2.5 or be constructed in accordance with the following:

1. A roof/ceiling assembly with framing oriented perpendicular to a 1-hour wall shall be constructed in accordance with Figure R302.2.1(1). The roof sheathing shall be either fire-retardant-treated plywood or have not less than $\frac{5}{8}$ -inch (15.9 mm) Type X gypsum board installed under the standard plywood sheathing for a horizontal distance of not less than 4 feet (1219 mm) from the common lot line.
2. A roof/ceiling assembly with framing oriented parallel to a 1-hour wall shall be constructed in accordance with Figure R302.2.1(2).
3. A roof/ceiling assembly with framing oriented perpendicular to a “modified” 2-hour common wall shall be constructed in accordance with Figure R302.2.1(3). The roof sheathing shall be either fire-retardant-treated plywood or have not less than $\frac{5}{8}$ -inch (15.9 mm) Type X gypsum board installed under the standard plywood roof sheathing for a horizontal distance of not less than 4 feet (1219 mm) from the common lot line.
4. A roof/ceiling assembly with framing oriented parallel to a “modified” 2-hour common wall shall be constructed in accordance with Figure R302.2.1(4).
5. As an alternate to Items 1 through 4, the entire ceiling of the upper story shall be protected throughout with two layers of $\frac{5}{8}$ -inch (15.9 mm) Type X gypsum board as required for a 1-hour fire-resistance-rated roof/ceiling assembly. Where roof framing is parallel to a common townhouse separation wall, a 1-hour attic enclosure “mushroom” may be constructed according to Figure R302.2.6.1, and the two layers of $\frac{5}{8}$ -inch (15.9 mm) Type X gypsum board on the ceiling may terminate at the outside vertical edge of the “mushroom.”

R302.2.6.2 **Roof/ceiling penetrations.** Membrane penetrations of the fire-resistance-rated ceiling required by Section R302.2.6.1 shall be protected by an approved penetration firestop system in accordance with Sections R302.4.1.1 and R302.4.1.2. Through-penetrating items shall be enclosed within a shaft constructed in accordance with the Building Code.

Skylights, mechanical and plumbing vents, attic vents, solar collectors and similar penetrations of the roof are not permitted within 4 feet (1219 mm) of the common lot line.

Exceptions:

1. Chimneys may penetrate roofs less than 4 feet (1219 mm) from a common lot line where a spark arrestor is

installed at the terminus. Where factory-built chimneys are located less than 4 feet (1219 mm) from a common lot line, they shall be enclosed within 1-hour fire-resistance-rated shafts constructed in accordance with the Building Code. Such shafts shall extend from where the factory-built chimney first penetrates a fire-resistance-rated wall or ceiling and shall continue to the uppermost termination of the chimney.

2. Unprotected factory-built chimneys and other unprotected penetrations are allowed less than 4 feet (1219 mm) from common lot lines where parapets are provided in accordance with Section R302.2.5.

R302.2.6.3 Cricket construction. Where crickets are installed, one of the following methods of construction shall be used:

1. Where crickets are 30 inches (762 mm) or less in height, the common fire-resistant townhouse separation wall may terminate at the underlying roof sheathing. The underlying roof sheathing shall be protected with either fire-retardant-treated plywood or have not less than 5/8-inch (15.9 mm) Type X gypsum board installed under the standard plywood roof sheathing for the full extent of the cricket, but not less than 4 feet (1219 mm) measured horizontally from the common lot line. There shall be no openings in the roof sheathing under the cricket [see Figures R302.2.6.3(1) and R302.2.6.3(2)].
2. Where crickets greater than 30 inches in height are provided, the common fire-resistant townhouse separation wall shall extend to the cricket roof sheathing, and the cricket roof sheathing shall be protected with either fire-retardant-treated plywood or have not less than 5/8-inch (15.9 mm) Type X gypsum board installed under the standard plywood roof sheathing for a horizontal distance of not less than 4 feet (1219 mm) on each side of the common lot line. There shall be no openings in the cricket sheathing [see Figure R302.2.6.3(3)].

R302.2.6.4 Eaves, cornices and similar projections. Projections located less than 3 feet (914 mm) from a common lot line shall be in accordance with this section. Structural projections such as enclosed eaves and cornices located less than 3 feet (914 mm) from a common lot line shall be constructed in accordance with Table R302.2.6.4. Projections within 3 feet (914 mm) of an exterior common lot line shall be in accordance with Section R302.1.

R302.2.7 Structural design approach. Townhouse structures shall be permitted to be designed as structurally dependent structures, structurally independent structures or a combination of both. See Figure R302.2.7.

R302.2.7.1 Lateral force analysis. A lateral force analysis shall be submitted at the time of application where townhouses or portions of townhouses are designed in accordance with Section R301.1.3 as either structurally independent or structurally dependent. Townhouses designed using only the prescriptive provisions of this code are exempt from this requirement. Building components providing lateral resistance shall be identified and detailed in the construction documents.

R302.2.7.2 R302.2.6 Structural independence. ~~Each townhouse unit shall be structurally independent.~~ Townhouses designed and constructed as structurally independent in accordance with the prescriptive provisions of this code shall be permitted to share the following elements:

Exceptions:

1. Foundations supporting exterior walls or common walls and monolithic grade beam footings.
2. Structural roof and wall sheathing from each unit fastened to the common wall framing. These elements shall be edge fastened at each side of the common lot line.
3. Nonstructural wall and roof coverings.
4. Flashing at termination of roof covering over common wall.
- ~~5. Townhouse units separated by a common wall as provided in Section R302.2.2, Item 1 or 2.~~
- ~~6. Townhouse units protected by a fire sprinkler system complying with Section P2904 or NFPA 13D.~~
5. Modified 2-hour or a common 2-hour fire-resistance-rated wall as provided in Section R302.2.
6. Soffit enclosures.
7. Cricket framing.
8. Roof covering
9. Gutters and downspouts.
10. Porches and stairs.
11. Porch coverings.

Portions of structurally independent townhouses designed in accordance with Section R301.1.3 shall provide independent vertical and lateral load-resisting systems for such designed portions.

R302.2.7.3 Structural dependence. Structurally dependent townhouses shall be designed in accordance with Section R301.1.3.

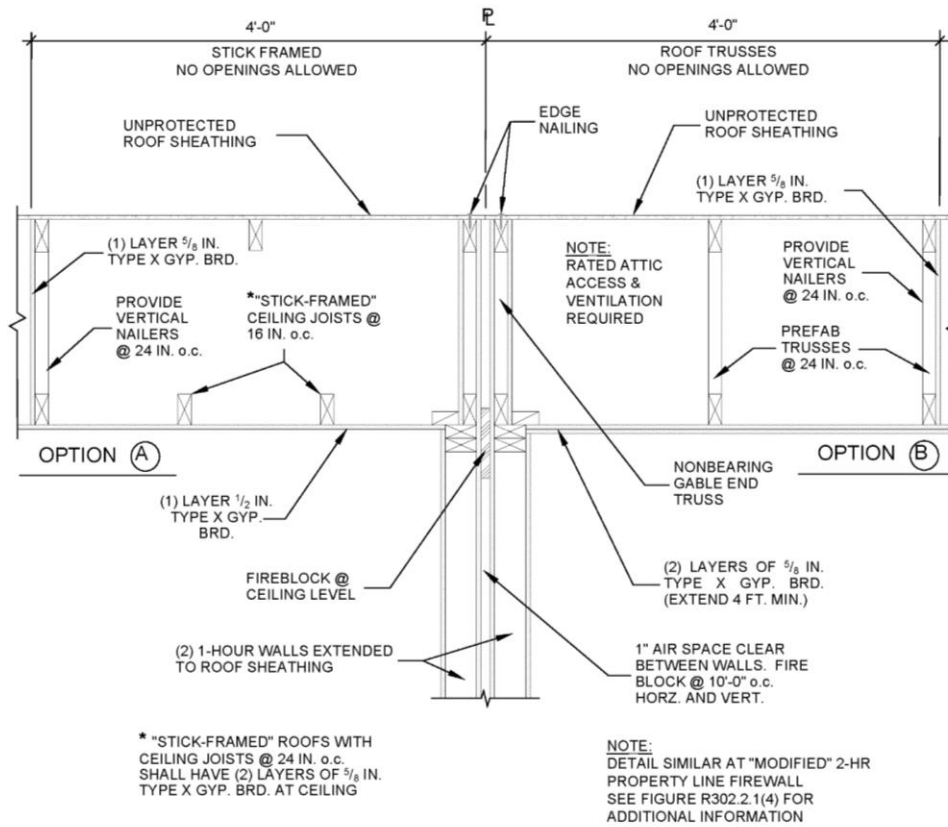

For SI: 1 inch = 25.4 mm.

FIGURE R302.2.6.1
FIRE-RESISTANCE-RATED ROOF/CEILING CONSTRUCTION—
"MUSHROOM" ATTIC ENCLOSURE FRAMING PARALLEL TO COMMON LOT LINE

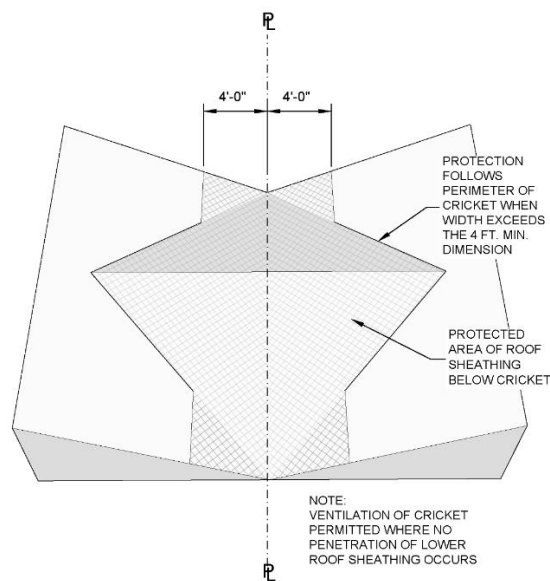

For SI: 1 inch = 25.4 mm.

FIGURE R302.2.6.3(1)
UNRATED CRICKET LESS OR EQUAL TO 30 INCHES

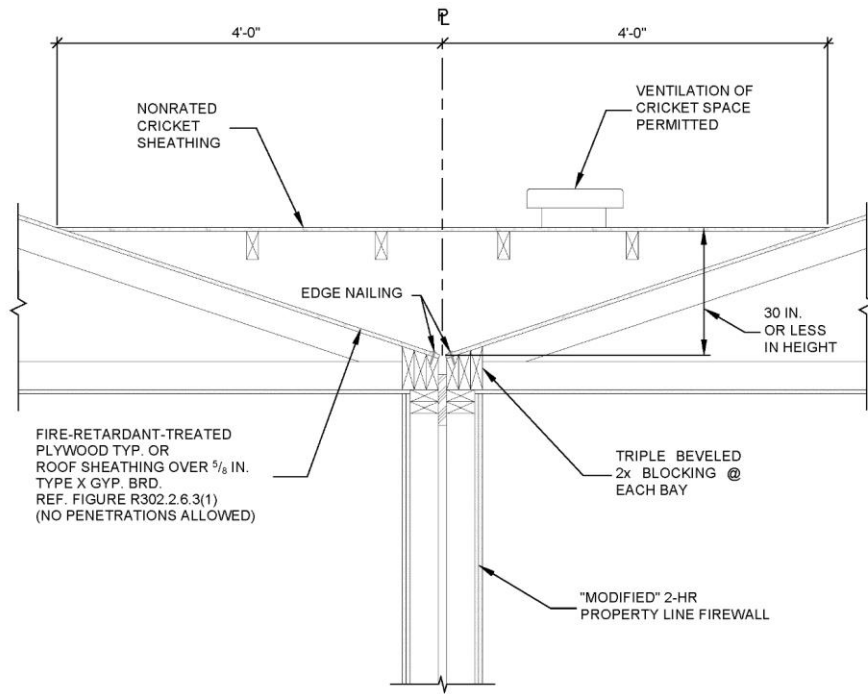

- NOTES:
1. DETAIL IS SIMILAR FOR (2) 1-HR FIREWALL OPTION
 2. SEE FIGURE R302.2.1(3) FOR ADDITIONAL INFORMATION

For SI: 1 inch = 25.4 mm.

FIGURE R302.2.6.3(2)
UNRATED CRICKET LESS THAN OR EQUAL TO 30 INCHES

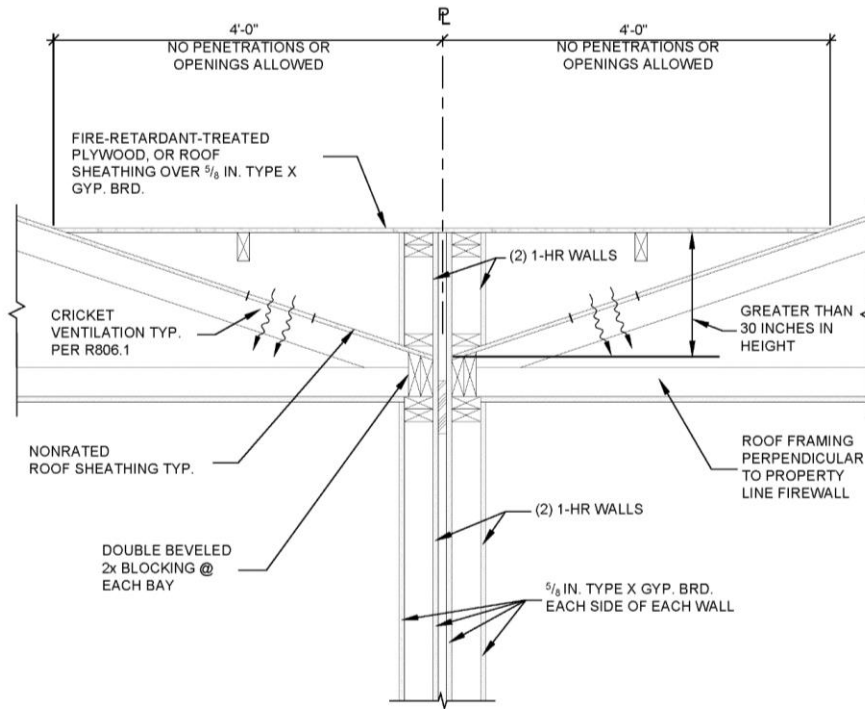

- NOTES:
1. DETAIL IS SIMILAR FOR MODIFIED FIREWALL OPTION
 2. SEE FIGURE R302.2.1(1) FOR ADDITIONAL INFORMATION

For SI: 1 inch = 25.4 mm.

FIGURE R302.2.6.3(3)
RATED CRICKET GREATER THAN 30 INCHES

**TABLE R302.2.6.4
STRUCTURAL PROJECTIONS LOCATED LESS THAN 3 FEET FROM ANY LOT LINE**

<u>EAVES, RAKES, CORNICES & SIMILAR PROJECTIONS^a</u>	<u>RELATIONSHIP OF FASCIA/BARGE TO PROPERTY LINE</u>	<u>EAVE VENTILATION PERMITTED</u>	<u>MAXIMUM LENGTH OF PROJECTION</u>	<u>PARAPET OR ROOF PROTECTION REQUIRED</u>	<u>MAXIMUM PROJECTION LENGTH BEYOND PROPERTY LINE</u>	<u>1-HOUR-RATED PROTECTION REQUIRED</u>
Enclosed with roof framing perpendicular to property line	Parallel	No	12" maximum	Yes	12" maximum	Yes
Unenclosed with roof framing perpendicular to property line	Parallel	No	12" maximum	Yes	12" maximum	No
Enclosed with roof framing parallel to property line	Perpendicular	No	24" maximum	No	12" maximum	Yes
Unenclosed with roof framing parallel to property line	Perpendicular	Yes	24" maximum	No	12" maximum	No

For SF: 1 inch = 25.4 mm.

a. Does not apply to exterior balconies.

R302.2.8 Fire-resistance-rated walls and cantilevers.

R302.2.8.1 Location on property. *Townhouse exterior walls, privacy walls, common townhouse separation walls, exterior stairways, porches, porch coverings, decks, roofs and projections located less than 3 feet (914 mm) from a common or exterior lot line shall be fire-resistance rated and constructed in accordance with this section.*

Exception: *Walls oriented perpendicular to a common lot line need not be fire-resistance-rated construction and may have unprotected openings.*

R302.2.8.1.1 Townhouse wall construction. *Exterior walls, privacy walls and common townhouse separation walls shall be parallel to the common lot line and be of fire-resistance-rated construction. Such walls shall be of the types listed in Section R302.2 or other listed, tested assemblies that provide an equivalent fire-resistance rating.*

R302.2.8.2 Cantilevered living areas. *Cantilevered living areas shall be protected by one of the following methods:*

1. *Where one cantilever is adjacent to another cantilever, and both are less than 3 feet (914 mm) from the common lot line, a single 1-hour fire-resistance-rated townhouse separation wall shall be provided for each cantilever. The townhouse separation walls shall extend to the farthest point where the cantilevers are adjacent.*
2. *Where one cantilever abuts another adjacent cantilever at a common lot line, either two 1-hour fire-resistance-rated walls or one "modified" 2-hour fire-resistance-rated common townhouse separation wall shall be provided. The townhouse separation wall shall extend to the farthest point where both cantilevers are adjacent.*

3. *Where there is one cantilever within 3 feet of the common lot line and no adjacent cantilever less than 3 feet (914 mm) from the common lot line, a 1-hour fire-resistance-rated exterior wall shall be provided. The exterior wall shall extend to the farthest point of the cantilever.*

The fire-resistance-rated walls required in Items 1 through 3 shall be continuous from the foundation to the roof sheathing where the roof/ceiling assembly is constructed in accordance with Section R302.2.6.1. Where the roof/ceiling assembly is not constructed in accordance with Section R302.2.6.1, the wall shall terminate in a parapet constructed in accordance with Section R302.2.5.

Exceptions:

1. *Cantilevers may be unprotected where each individual townhouse is provided with a fire suppression system in accordance with NFPA 13D.*
2. *The extension of fire-resistance-rated walls beneath the cantilever may be omitted, provided that the exterior wall perpendicular to the common lot line is 1-hour fire-resistance-rated construction for a distance of 4 feet (1219 mm) on each side of the common lot line from the foundation to the bottom of the cantilever. Foundation vents shall not be located less than 4 feet (1219 mm) from the common lot line. The soffit area under the cantilever shall have not less than 1-hour fire-resistance-rated protection for a distance of not less than 4 feet (1219 mm) on each side of the common lot line. Where the cantilever projects less than 4 feet (1219 mm) from the face of the building, the prohibition of openings and the fire-resistance-rated wall and soffit construction perpendicular to the common lot line need only extend for a distance equal to the projection of the cantilever.*

R302.2.8.3 Openings. Openings in fire-resistant exterior walls, privacy walls and individual townhouse separation walls are not permitted.

R302.2.9 Townhouse dwelling unit and garage separations. Townhouses shall be separated from attached garages in accordance with Section R302.6.

R302.2.10 Townhouse interior duct and vent chase penetrations of floor/ceiling assemblies. Gas vents, ducts, piping and factory-built chimneys that extend through not more than two floors need not be enclosed, provided that the openings around the penetrations are fire-stopped at each floor.

Exception: Type BW gas vents installed in accordance with their listing.

R302.2.11 Townhouse foundation and footing construction. A single footing and foundation wall may be designed and constructed for common lot line walls in accordance with this section, Figure R302.2.11 and Chapter 4. Through penetrations of the foundation across a common lot line are not permitted. If required by local conditions, footing drains, rain drains and low point under-floor drainage shall be provided and drained to an approved location.

R302.2.12 Townhouse roof coverings. In addition to the requirements of Chapter 9, structurally independent townhouses shall be provided with a minimum Class C roof covering, and structurally dependent townhouses shall be provided with a minimum Class B roof covering.

Exceptions:

1. Structurally dependent townhouses may use Class C roof coverings where all of the following conditions are met:

1.1. The townhouses are not more than two stories in height.

1.2. The townhouses do not have more than 6,000 square feet (557 m²) of projected roof area.

1.3. There is not less than 3 feet (914 mm) from the extremity of the roof to the exterior lot line or an assumed lot line on all sides except for street fronts.

2. Roof coverings for townhouses located in areas determined by the municipality to be "Wildfire Hazard Zones" shall be in accordance with Section R327.

R302.2.13 Townhouse dwelling unit egress. Each individual townhouse shall have a means of egress system in accordance with Section R311. Such means of egress system shall be a structurally independent exit way, having a clear width of not less than 3 feet (914 mm).

R302.2.14 Townhouse adaptability/accessibility. Where the project includes four or more contiguous individual townhouses, one or more of which is single story, the requirements of the Fair Housing Act and Chapter 11 of the Building Code apply. Ground-level, single-story townhouses shall be made accessible in accordance with the requirements for Group R-3 occupancies in Chapter 11 of the Building Code. Any common-use facilities such as a clubhouse or management office shall be made accessible in accordance with Chapter 11 of the Building Code.

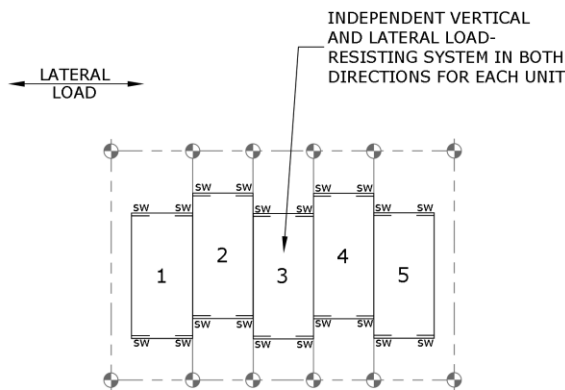

A STRUCTURALLY "INDEPENDENT" EXAMPLE

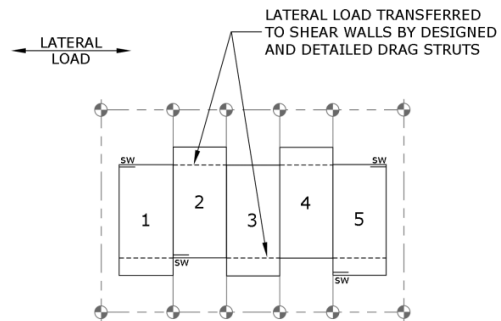

B STRUCTURALLY "DEPENDENT" EXAMPLE

SW = Possible shear wall location

For SI: 1 inch = 25.4 mm.

FIGURE R302.2.7
STRUCTURAL DESIGN APPROACH

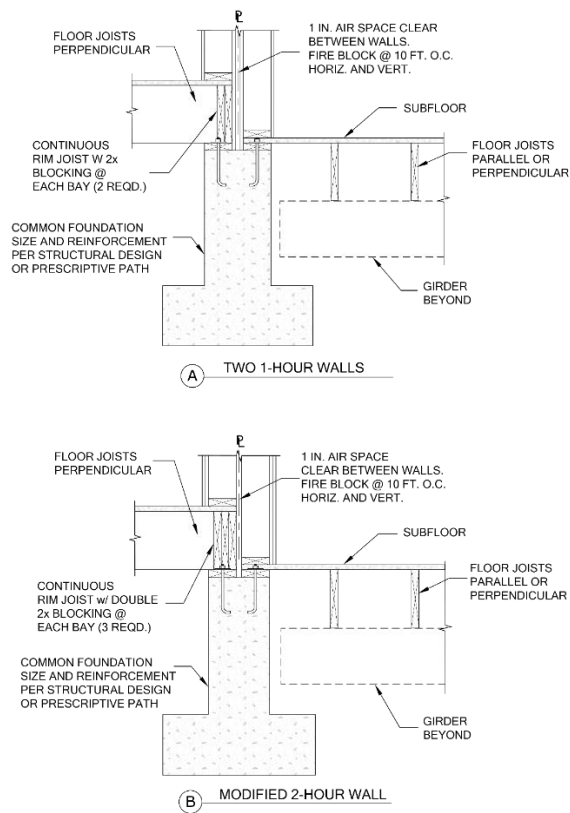

FIGURE R302.2.11
FOUNDATION AND FOOTING CONSTRUCTION

R302.3 Two-family dwellings. *Dwelling units* in two-family dwellings shall be separated from each other by wall and floor assemblies having not less than a 1-hour fire-resistance rating where tested in accordance with ASTM E119, UL 263 or Section 703.2.2 of the *Building Code*. ~~Such separation shall be provided regardless of whether a lot line exists between the two dwelling units or not.~~ Fire-resistance-rated floor/ceiling and wall assemblies shall extend to and be tight against the exterior wall, and wall assemblies shall extend from the ~~foundation~~ top of the lowest floor sheathing to the underside of the roof sheathing.

Exceptions:

1. A fire-resistance rating of 1/2 hour shall be permitted in buildings equipped throughout with an automatic sprinkler system installed in accordance with [NFPA 13D](#).

[Exception 2 remains unchanged.]

R302.3.1 Supporting construction. Where floor assemblies are required to be fire-resistance rated by Section R302.3, the supporting construction of such assemblies shall have an equal or greater fire-resistance rating.

R302.3.2 Lot line separation. Where a two-family dwelling is separated by a lot line, dwelling unit separation shall be provided in accordance with one of the following:

1. Townhouse provisions of Section R302.2, as applicable.
2. Two individual wall assemblies having not less than a 1-hour fire-resistance rating and tested in accordance with ASTM E119 or UL 263.
3. Other approved methods of equivalent fire resistance.

R302.4.1 Through penetrations. Through penetrations in fire-resistance-rated exterior walls, privacy walls and individual or common townhouse separation walls are not permitted in townhouses. In other than townhouses, through penetrations of fire-resistance-rated wall or floor assemblies shall comply with Section R302.4.1.1 or R302.4.1.2.

Exceptions:

1. In other than townhouses, where the penetrating items are steel, ferrous or copper pipes, tubes or conduits, the annular space shall be protected as follows:

[The rest of this section remains unchanged.]

R302.4.2 Membrane penetrations. Membrane penetrations in townhouses shall comply with this section and Section R302.4.2.1.
[The rest of this section remains unchanged.]

R302.4.2.1 Additional townhouse membrane penetration requirements. Membrane penetrations in townhouse fire-resistance-rated exterior walls, privacy walls and individual townhouse separation walls are allowed as provided in Section R302.2.

Exceptions: Membrane penetrations in townhouse fire-resistance-rated walls:

1. Shall be protected with a listed penetration firestop system rated for not less than 2 hours where the penetration is in a common “modified” 2-hour fire-resistance-rated wall.
2. May have the minimum separation distance of 24 inches (610 mm) between electrical boxes reduced where installed in accordance with Figure R302.4.2.1, Details C and D.
3. For large boxes such as washer connections, electrical panels and wall heaters may be installed where the fire protection extends behind the box in accordance with Figure R302.4.2.1, Details B and D.
4. Stair stringers shall be in accordance with Section R302.2.4.

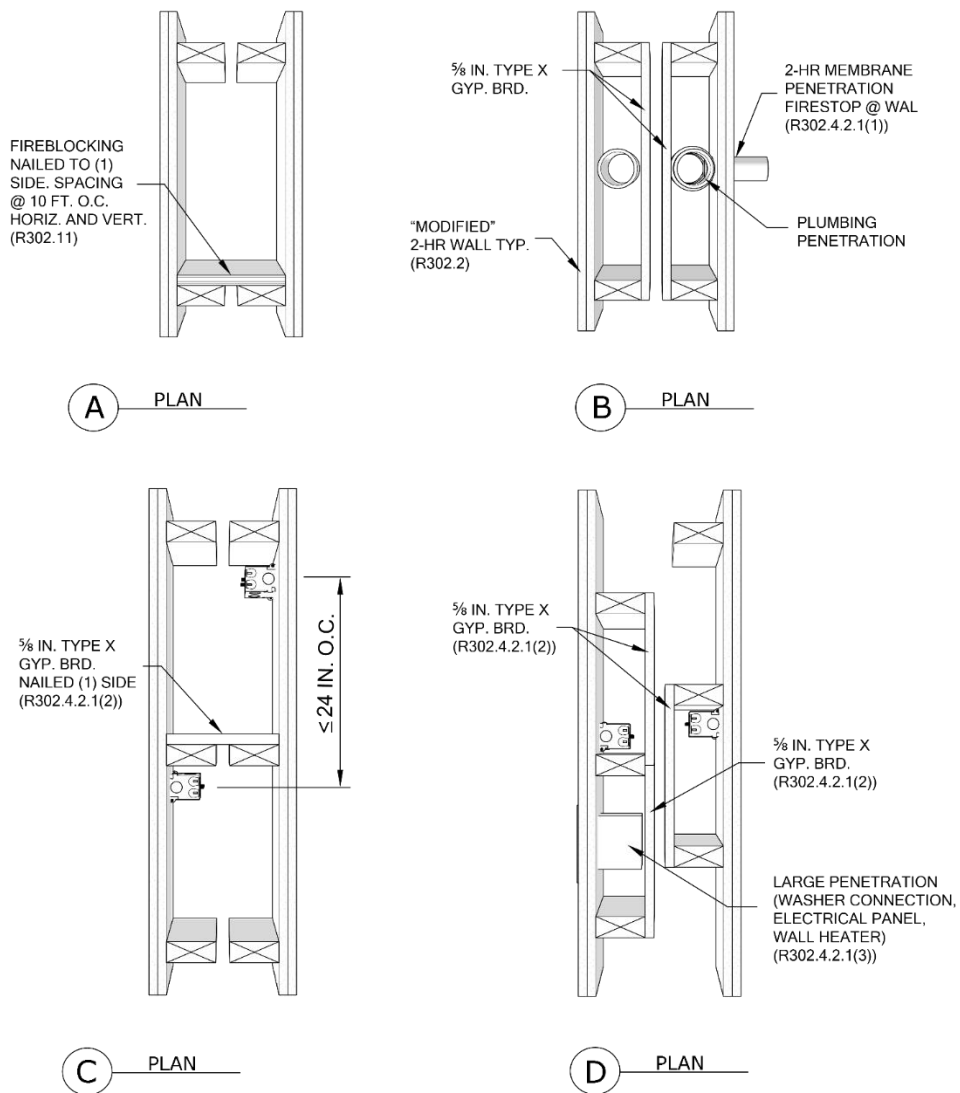

NOTE: THROUGH PENETRATIONS ARE PROHIBITED IN TOWNHOUSE STRUCTURES BY SECTION R302.4.1. TOWNHOUSE MEMBRANE PENETRATIONS SHALL COMPLY WITH SECTION R302.4.2, SECTION R302.4.2.1, AND FIGURE R302.4.2.1, AS APPLICABLE.

FIGURE R302.4.2.1
MEMBRANE PENETRATIONS FOR MODIFIED 2-HOUR WALLS

R302.5.1 ~~Opening protection~~ Garage openings. Openings from a private garage directly into a room used for sleeping purposes shall not be permitted.

R302.5.1.1 Opening protections. Other openings between the garage and residence shall be equipped with solid wood doors not less than 1³/₈ inches (35 mm) in thickness, solid or honeycomb-core steel doors not less than 1³/₈ inches (35 mm) thick, or 20-minute fire-rated doors. ~~Doors shall be self-latching and equipped with a self-closing or automatic-closing device.~~

Exception: Compliance with this section shall not be required where both the dwelling unit and garage are protected by an automatic fire sprinkler system installed in accordance with NFPA 13D or other approved automatic fire sprinkler system.

R302.5.2 Duct penetration. Ducts in the garage and ducts penetrating the walls or ceilings separating the dwelling from the garage shall be constructed of a minimum No. 26 gage (0.48 mm) sheet steel or other approved material and shall not have openings into the garage. Where a vibration isolator is used in the garage duct, it shall be installed not less than 18 inches (457 mm) from the penetration.

**TABLE R302.6
DWELLING-GARAGE SEPARATION**

SEPARATION	MATERIAL
From the residence and attics	Not less than 1/2-inch gypsum board or equivalent applied to the garage side
From habitable rooms above the garage	Not less than 5/8-inch Type X gypsum board or equivalent
Structure(s) Walls and other structural elements supporting floor/ceiling assemblies used for separation required by this section	Not less than 1/2-inch gypsum board or equivalent
Garages located less than 3 feet from a dwelling unit on the same lot	Not less than 1/2-inch gypsum board or equivalent applied to the interior side of exterior walls that are within this area

For SI: 1 inch = 25.4 mm, 1 foot = 304.8 mm.

R302.7 Under-stair protection. Enclosed space under stairs that is accessed by a door or access panel shall have walls, under-stair surface and any soffits protected on the enclosed side with 1/2-inch (12.7 mm) gypsum board.

Exception: Under-stair protection shall not be required where both the dwelling unit and under-stair area are protected by an automatic fire sprinkler system installed in accordance with NFPA 13D or other approved automatic fire sprinkler system.

R302.11 Fireblocking. In combustible construction, fireblocking shall be provided to cut off both vertical and horizontal concealed draft openings and to form an effective fire barrier between stories, and between a top story and the roof space.

Fireblocking shall be provided in wood-framed construction in the following locations:

1. In concealed spaces of stud walls and partitions, including furred spaces and parallel rows of studs or staggered studs, as follows:
 - 1.1. Vertically at the ceiling and floor levels.
 - 1.2. Horizontally at intervals not exceeding 10 feet (3048 mm).

Exception: Fireblocking is not required for furred spaces providing drainage in accordance with Section R703.1, where the space does not communicate with the wall cavity or attic. The use of furring or caulking installed horizontally directly below eave vents may be used to interrupt communication with the attic.

[The rest of this section remains unchanged.]

IRC R302.14 Combustible insulation clearance. *...Not adopted.*

SECTION R303 LIGHT, VENTILATION AND HEATING

R303.1 Habitable rooms. Habitable rooms shall have an aggregate glazing area of not less than 8 percent of the floor area of such rooms. Natural *ventilation* shall be through windows, skylights, doors, louvers or other *approved* openings to the outdoor air. Such openings shall be provided with ready access or shall otherwise be readily controllable by the building occupants. The openable area to the outdoors shall be not less than 4 percent of the floor area being ventilated.

Exceptions:

1. For habitable rooms other than kitchens, the glazed areas need not be openable where the opening is not required by Section R310 and a whole-house mechanical *ventilation* system or a mechanical ventilation system capable of producing 0.35 air changes per hour in the habitable rooms is installed in accordance with Section M1505.
2. For kitchens, the glazed areas need not be openable where the opening is not required by Section R310 and a local exhaust system is installed in accordance with Section M1505.
3. The glazed areas need not be installed in rooms where Exception 1 is satisfied and artificial light is provided that is capable of producing an average illumination of 6 footcandles (65 lux) over the area of the room at a height of 30 inches (762 mm) above the floor level.
4. Use of *sunroom* and deck, patio or porch covers, as defined in Section R202, shall be permitted for natural *ventilation* if in excess of 40 percent of the exterior *sunroom* walls are open, or are enclosed only by insect screening.

R303.2 Adjoining rooms. For the purpose of determining light and *ventilation* requirements, rooms shall be considered to be a portion of an adjoining room where not less than one-half of the area of the common wall is open and unobstructed and provides an opening of not less than one-tenth of the floor area of the interior room and not less than 25 square feet (2.3 m²).

Exception: Openings required for light or *ventilation* shall be permitted to open into a *sunroom* with thermal isolation or a deck, patio or porch cover, provided that there is an openable area between the adjoining room and the *sunroom* or deck, patio or porch cover of not less than one-tenth of the floor area of the interior room and not less than 20 square feet (2 m²). The minimum openable area to the outdoors shall be based on the total floor area being ventilated.

R303.3 ~~Bathrooms~~-Toilet and bathing facility ventilation.

R303.3.1 Rooms with bathing or spa facilities. Any room with a bathtub, shower or spa facility shall be provided with mechanical ventilation designed and installed in accordance with Section M1505.

R303.3.2 Rooms without bathing or spa facilities. Bathrooms, Water closet compartments and other similar or toilet rooms without bathtub, shower or spa facilities shall be provided with aggregate glazing area in windows of not less than 3 square feet (0.3 m²), one-half of which shall be openable.

Exception: The glazed areas shall not be required where artificial light and a ~~local exhaust~~-mechanical ventilation system are provided in accordance with Section M1505. The minimum ~~local exhaust~~-ventilation rates shall be ~~determined~~ in accordance with Table M1505.5-~~Section M1505~~. ~~Exhaust air from the space shall be exhausted directly to the outdoors.~~

R303.4 Mechanical ventilation. ~~Buildings and Newly constructed~~ dwelling units complying with Section N1102.4.1 shall be provided with whole-house mechanical ventilation in accordance with Section M1505, or with other *approved* means of ventilation.

R303.9.1 Sunroom additions. Required glazed openings shall be permitted to open into *sunroom additions* or deck, patio or porch covers that abut a street, yard or court if in excess of 40 percent of the exterior *sunroom* walls are open, or are enclosed only by insect screening, and the ceiling height of the *sunroom* is not less than 7 feet (2134 mm).

R303.10 Required heating. ~~Where the winter design temperature in Table R301.2 is below 60°F (16°C),~~ Every dwelling unit shall be provided with heating facilities capable of maintaining a room temperature of not less than 68°F (20°C) at a point 3 feet (914 mm) above the floor and 2 feet (610 mm) from *exterior walls* in habitable rooms at the design temperature. The installation of one or more portable space heaters shall not be used to achieve compliance with this section.

SECTION R305 CEILING HEIGHT

R305.1 Minimum height. *Habitable space*, hallways and portions of *basements* containing these spaces shall have a ceiling height of not less than 7 feet (2134 mm). Bathrooms, toilet rooms and laundry rooms shall have a ceiling height of not less than 6 feet 8 inches (2032 mm).

Exceptions:

1. For rooms with sloped ceilings, the required floor area of the room shall have a ceiling height of not less than 5 feet (1524 mm) and not less than 50 percent of the required floor area shall have a ceiling height of not less than 7 feet (2134 mm).
- ~~2. The ceiling height above bathroom and toilet room fixtures shall be such that the fixture is capable of being used for its intended purpose. A shower or tub equipped with a showerhead shall have a ceiling height of not less than 6 feet 8 inches (2032 mm) above an area of not less than 30 inches (762 mm) by 30 inches (762 mm) at the showerhead.~~
2. Not more than 75 percent of the floor area of a bathroom or toilet room is permitted to have a sloped ceiling less than 6 feet 8 inches (2032 mm) in height, provided that an area of 21 inches by 24 inches (534 mm by 610 mm) in front of toilets and lavatories has a minimum of 6 feet 4 inches (1931 mm) in height, measured from the finished floor. An area of 24 inches by 30 inches (610 mm by 762 mm) in front of and inside a tub or shower shall have a minimum of 6 feet 4 inches (1931 mm) in height, measured from the standing surface of the fixture.
3. Beams, girders, ducts or other obstructions in *basements* containing *habitable space* shall be permitted to project to within 6 feet 4 inches (1931 mm) of the finished floor.
- ~~4. Beams and girders spaced apart not less than 36 inches (914 mm) in clear finished width shall project not more than 78 inches (1981 mm) from the finished floor.~~
5. Beams and girders spaced not less than 4 feet (1219 mm) on center may project not more than 6 inches (152 mm) below the required ceiling height.
6. Conversion of existing nonhabitable space, such as a basement or attic, to habitable space, shall provide a ceiling height of not less than 6 feet 8 inches (2032 mm) for flat ceilings or for the portion of ceiling required in Exception 1 of this section.

SECTION R306 SANITATION

R306.3 Sewage disposal. Plumbing fixtures shall be connected to a sanitary sewer or to an *approved* private sewage disposal system in accordance with the *Plumbing Code*.

R306.4 Water supply to fixtures. Plumbing fixtures shall be connected to an *approved* water supply in accordance with the *Plumbing Code*. Kitchen sinks, lavatories, bathtubs, showers, bidets, laundry tubs and washing machine outlets shall be provided with hot and cold water.

SECTION R307 TOILET, BATH AND SHOWER SPACES

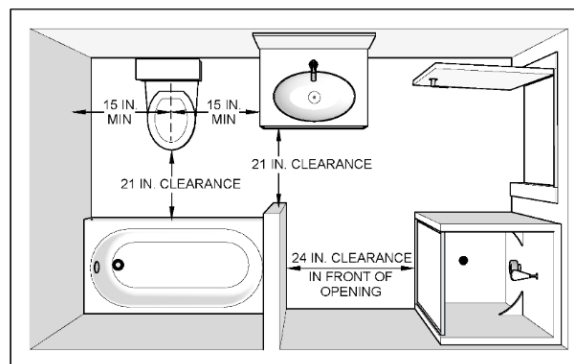

FIGURE R307.1
MINIMUM FIXTURE CLEARANCES
(See the *Plumbing Code* for shower clearances.)

SECTION R308 GLAZING

R308.4.2 Glazing adjacent to doors. Glazing in an individual fixed or operable panel adjacent to a door shall be considered to be a hazardous location where the bottom exposed edge of the glazing is less than 60 inches (1524 mm) above the floor or walking surface and it meets either of the following conditions:

1. Where the glazing is within 24 inches (610 mm) of either side of the door in the plane of the door in a closed position.
2. Where the glazing is on a wall less than 180 degrees (3.14 rad) from the plane of the door in a closed position and within 24 inches (610 mm) of the hinge side of an in-swinging door. [See Figure R308.4.2.](#)

Exceptions:

1. Decorative glazing.
2. Where there is an intervening wall or other permanent barrier between the door and the glazing.
3. Where access through the door is to a closet or storage area 3 feet (914 mm) or less in depth. Glazing in this application shall comply with Section R308.4.3.
4. Glazing that is adjacent to the fixed panel of patio doors.

* INDICATES SAFETY GLAZING NOT REQUIRED

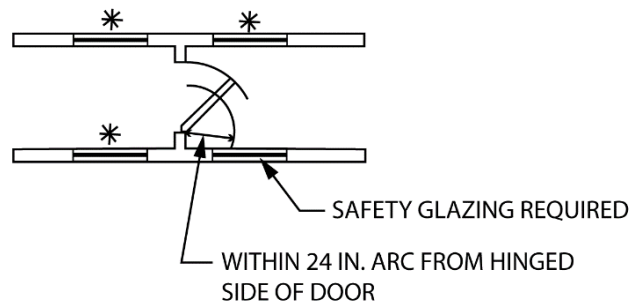

FIGURE R308.4.2
GLAZING ADJACENT TO DOOR

R308.4.5 Glazing and wet surfaces. Glazing in walls, enclosures or fences containing ~~or adjacent to~~ [or facing](#) hot tubs, spas, whirlpools, saunas, steam rooms, bathtubs, showers and indoor or outdoor swimming pools where the bottom exposed edge of the glazing is less than 60 inches (1524 mm) measured vertically above any standing or walking surface shall be considered to be a hazardous location. This shall apply to single glazing and each pane in multiple glazing.

Exception: Glazing that is more than 60 inches (1524 mm), measured horizontally, from the water's edge of a bathtub, hot tub, spa, whirlpool or swimming pool or from the edge of a shower, sauna or steam room.

Figure R308.4.7 – *See Oregon figure below.*

R308.6.9.1 Comparative analysis for glass-glazed unit skylights. Structural wind load design pressures for glass-glazed *unit skylights* different than the size tested in accordance with Section R308.6.9 shall be permitted to be different than the design value of the tested unit where determined in accordance with one of the following comparative analysis methods:

1. Structural wind load design pressures for glass-glazed *unit skylights* smaller than the size tested in accordance with Section R308.6.9 shall be permitted to be higher than the design value of the tested unit provided that such higher pressures are determined by ~~accepted engineering-an~~ [approved](#) analysis. Components of the smaller unit shall be the same as those of the tested unit. Such calculated design pressures shall be validated by an additional test of the glass-glazed *unit skylight* having the highest allowable design pressure.
2. In accordance with WDMA I.S.11.

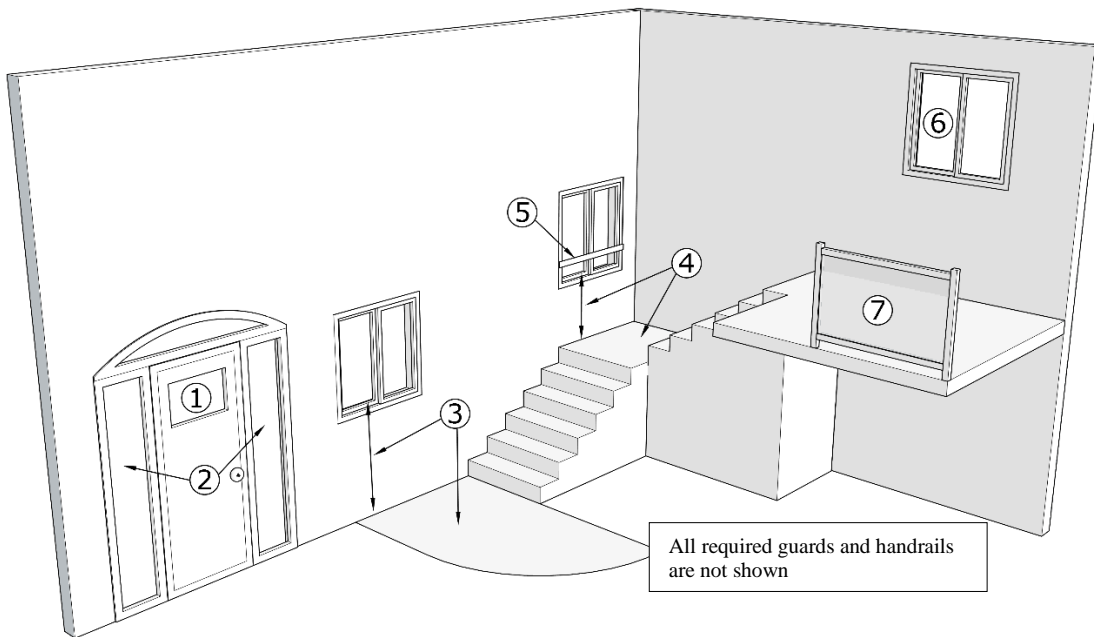

For SI: 1 inch = 25.4 mm, 1 square foot = 0.0929 m².

Notes:

1. Glazing in fixed and operable panels of swinging, sliding and bifold doors shall be considered to be a hazardous location. (R308.4.1)
2. Glazing in an individual fixed or operable panel adjacent to a door shall be considered to be a hazardous location where the bottom exposed edge of the glazing is less than 60 inches above the floor or walking surface and where the glazing is within 24 inches of either side of the door in the plane of the door in a closed position. (R308.4.2)
3. Glazing adjacent to the landing at the bottom of a stairway where the glazing is less than 36 inches above the landing and within a 60-inch horizontal arc less than 180 degrees from the bottom tread nosing shall be considered to be a hazardous location. (R308.4.7)
4. Glazing where the bottom exposed edge of the glazing is less than 36 inches above the plane of the adjacent walking surface of stairways, landings between flights of stairs and ramps shall be considered to be a hazardous location. (R308.4.6)
5. Where a rail is installed on the accessible side(s) of the glazing 34 to 38 inches above the walking surface, safety glazing is not required. The rail shall be capable of withstanding a horizontal load of 50 pounds per linear foot without contacting the glass and have a cross-sectional height of not less than 1½ inches. (R308.4.6, Exception 1)
6. Glazing in an individual fixed or operable panel that meets all of the following conditions shall be considered to be a hazardous location:
 - a. The exposed area of an individual pane is larger than 9 square feet.
 - b. The bottom edge of the glazing is less than 18 inches above the floor.
 - c. The top edge of the glazing is more than 36 inches above the floor.
 - d. One or more walking surfaces are within 36 inches, measured horizontally and in a straight line, of the glazing. (R308.4.3) (ORSC R308.4.6, Exception 1 as noted in item 5 also applies to this condition)
7. Glazing in guards and railings, including structural baluster panels and nonstructural in-fill panels, regardless of area or height above a walking surface, shall be considered to be a hazardous location. (R308.4.4)

FIGURE R308.4.7
HAZARDOUS GLAZING LOCATIONS AT BOTTOM STAIR LANDINGS

SECTION R309 GARAGES AND CARPORTS

R309.3 Flood hazard areas. Garages and carports located in flood hazard areas as established by [Table R301.2](#) *the flood plain administrator* shall be constructed in accordance with [Section R322](#).

IRC R309.5 Fire sprinkler. ...*Not adopted.*

SECTION R310 EMERGENCY ESCAPE AND RESCUE OPENINGS

R310.1 Emergency escape and rescue opening required. Basements, habitable attics and every sleeping room shall have not less than one operable emergency escape and rescue opening. Where basements contain one or more sleeping rooms, an emergency escape and rescue opening shall be required in each sleeping room. Emergency escape and rescue openings shall open directly into a public way, or to a yard or court having a minimum width of 36 inches (914 mm) that opens to a public way.

Exceptions:

1. Storm shelters and basements used only to house mechanical equipment not exceeding a total floor area of 200 square feet (18.58 m²).
2. Where the dwelling unit or townhouse unit is equipped with an automatic sprinkler system installed in accordance with NFPA 13D, sleeping rooms in basements shall not be required to have emergency escape and rescue openings provided that the basement has one of the following:
 - 2.1. One means of egress complying with Section R311 and one emergency escape and rescue opening.
 - 2.2. Two means of egress complying with Section R311.
3. A yard shall not be required to open directly into a public way where the yard opens to an unobstructed path from the yard to the public way. Such path shall have a width of not less than 36 inches (914 mm).

R310.1

Model code changes:

New model code includes a clear 36-inch-wide path to a public way

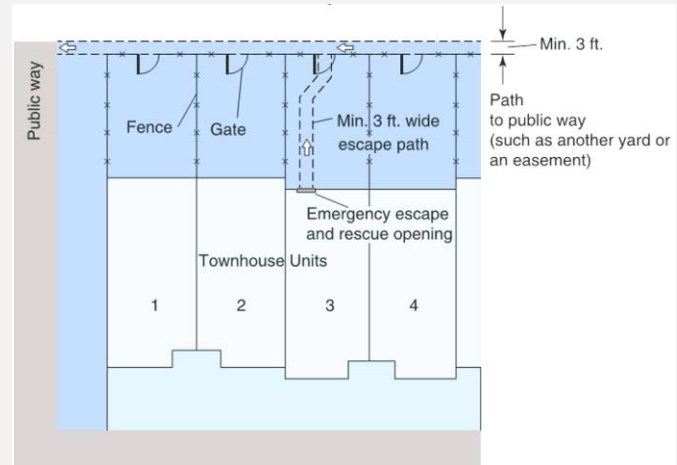

R310.1.1 Operational constraints and opening control devices. Emergency escape and rescue openings shall be operational from the inside of the room without the use of keys, tools or special knowledge. Window opening control devices and fall prevention devices complying with ASTM F2090 shall be permitted for use on windows serving as a required emergency escape and rescue opening and shall be not more than 70 inches (178 cm) above the finished floor.

R310.2 Emergency escape and rescue openings. Emergency escape and rescue openings shall have minimum dimensions in accordance with Sections R310.2.1 through R310.2.5.

R310.2.1 Minimum size. Emergency escape and rescue openings shall have a net clear opening of not less than 5.7 square feet (0.530 m²).

Exception: The minimum net clear opening for grade-floor emergency escape and rescue openings shall be 5 square feet (0.465 m²).

R310.2.2 Minimum dimensions. The minimum net clear opening height dimension shall be 24 inches (610 mm). The minimum net clear opening width dimension shall be 20 inches (508 mm). The net clear opening dimensions shall be the result of normal operation of the opening.

R310.2.3 Maximum height from floor. Emergency escape and rescue openings shall have the bottom of the clear opening not greater than 44 inches (1118 mm) above the finished floor.

R310.2.4 Emergency escape and rescue openings under decks, porches, and cantilevers and similar projections. Emergency escape and rescue openings are permitted to be installed under decks, porches, and cantilevers and similar projections, provided that the location of the projection allows the emergency escape and rescue opening to be fully openable and provide a path not less than 36 inches (914 mm) in height and 36 inches (914 mm) in width to a yard or court.

R310.2.5 Emergency escape and rescue openings above lower roof surfaces. Emergency escape and rescue openings located above a portion of roof surface below shall be provided with an unobstructed path, not less than 36 inches (914 mm) in width, from the vertical plane of the opening to the nearest edge of the lower roof, as practicable.

Section R310.4 – Model code changes:

Window wells and area wells serving emergency escape and rescue openings have been combined into one section for area wells.

R310.4 Area wells. An *emergency escape and rescue opening* where the bottom of the clear opening is below the adjacent grade shall be provided with an area well in accordance with Sections R310.4.1 through R310.4.4.

R310.4.1 Minimum size. The horizontal area of the *area well* shall be not less than 9 square feet (0.9 m²), with a horizontal projection and width of not less than 36 inches (914 mm). The *size* of the *area well* shall allow the *emergency escape and rescue opening* to be fully opened.

Exception: The ladder or steps required by Section R310.4.2 shall be permitted to encroach not more than 6 inches (152 mm) into the required dimensions of the *area well*.

R310.4.2 Ladder and steps. *Area wells* with a vertical depth greater than 44 inches (1118 mm) shall be equipped with an *approved*, permanently affixed *ladder or steps*. The ladder or steps shall not be obstructed by the *emergency escape and rescue opening* where the window or door is in the open position. Ladders or steps required by this section shall not be required to comply with Section R311.7.

R310.4.2.1 Ladders. Ladders and rungs shall have an inside width of not less than 12 inches (305 mm), shall project not less than 3 inches (76 mm) from the wall and shall be spaced not more than 18 inches (457 mm) on center vertically for the full height of the *area well*.

R310.4.2.2 Steps. Steps shall have an inside width of not less than 12 inches (305 mm), a minimum tread depth of 5 inches (127 mm) and a maximum *riser* height of 18 inches (457 mm) for the full height of the *area well*.

R310.4.3 Drainage. *Area wells* shall be designed for proper drainage by connecting to the building's foundation drainage system required by Section R405.1.

Exception: A drainage system for *area wells* is not required where the foundation is on well-drained soil or sand-gravel mixture soils in accordance with the United Soil Classification System, Group I Soils, as detailed in Table R405.1.

R310.4.4 Bars, grilles, covers and screens. Where bars, grilles, covers, screens or similar devices are placed over *emergency escape and rescue openings*, *bulkhead enclosures or area wells that serve such openings*, the minimum net clear opening size shall comply with Sections R310.2 through R310.2.2 and R310.4.1. *Such* devices shall be releasable or removable from the inside without the use of a key or tool or force greater than that required for the normal operation of the escape and rescue opening.

R310.5 Replacement windows for emergency escape and rescue openings. Replacement windows installed in buildings meeting the scope of this code shall be exempt from Sections R310.2 and R310.4.4, provided that the replacement window meets the following conditions:

1. The replacement window is the manufacturer's largest standard size window that will fit within the existing frame or existing rough opening. The replacement window is of the same operating style as the existing window or a style that provides for an equal or greater window opening area than the existing window.
2. The replacement window is not part of a change of occupancy or use.

R310.6 Dwelling additions. Where *dwelling additions* contain sleeping rooms, an *emergency escape and rescue opening* shall be provided in each new sleeping room. Where *dwelling additions* have *basements*, an *emergency escape and rescue opening* shall be provided in the new *basement*.

Exceptions:

1. An *emergency escape and rescue opening* is not required in a new *basement* that contains a sleeping room with an *emergency escape and rescue opening*.
2. An *emergency escape and rescue opening* is not required in a new *basement* where there is an *emergency escape and rescue opening* in an existing *basement* that is *accessed* from the new *basement*.
3. An operable window complying with Section 310.7.1 shall be acceptable as an *emergency escape and rescue opening*.

R310.7 Alterations or repairs of existing basements. New sleeping rooms created in an existing *basement* shall be provided with *emergency escape and rescue openings* in accordance with Section R310.1. Other than new sleeping rooms, where existing basements undergo alterations or repairs, an *emergency escape and rescue opening* is not required.

Exception: An operable window complying with Section 310.7.1 shall be acceptable as an *emergency escape and rescue opening*.

R310.7.1 Existing emergency escape and rescue openings. Where a *change of occupancy* would require an *emergency escape and rescue opening* in accordance with Section 310.1, operable windows serving as the *emergency escape and rescue opening* shall comply with the following:

1. An existing operable window shall provide a minimum net clear opening of 4 square feet (0.38 m²) with a minimum net clear opening height of 22 inches (559 mm) and a minimum net clear opening width of 20 inches (508 mm).
2. A replacement window where such window complies with both of the following:
 - 2.1. The replacement window meets the size requirements in Item 1.
 - 2.2. The replacement window is the manufacturer's largest standard-size window that will fit within the existing frame or existing rough opening. The replacement window shall be permitted to be of the same operating style as the existing window or a style that provides for an equal or greater window opening area than the existing window.

Section R310.7 Model code changes:

Opening dimensions of emergency escape and rescue openings have been reduced for basement alterations, basement additions, and for changes of occupancy.

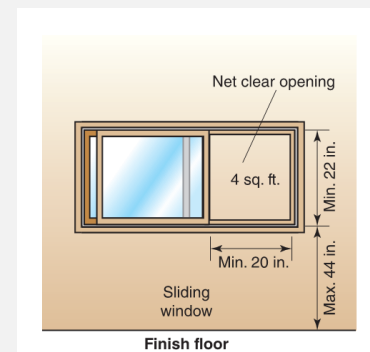

SECTION R311 MEANS OF EGRESS

R311.1 Means of egress. *Dwellings and accessory structures containing habitable space* shall be provided with a means of egress in accordance with this section. The means of egress shall provide a continuous and unobstructed path of vertical and horizontal egress travel from all portions of the *dwelling or habitable space* to the required egress door without requiring travel through a garage *or carport*. The required egress door shall open directly into a *public way* or to a *yard* or court that opens to a *public way*.

R311.3.1 Floor elevations at the required egress doors. Landings or finished floors at the required egress door shall be not more than 1¹/₂ inches (38 mm) lower than the top of the threshold.

Exception: The landing or floor on the exterior side shall be not more than ~~7³/₄ inches (196 mm)~~ **8 inches (203 mm)** below the top of the threshold provided that the door does not swing over the landing or floor.

Where exterior landings or floors serving the required egress door are not at *grade*, they shall be provided with access to *grade* by means of a *ramp* in accordance with Section R311.8 or a *stairway* in accordance with Section R311.7.

R311.3.2 Floor elevations at other exterior doors. Doors other than the required egress door shall be provided with landings or floors not more than ~~7³/₄ inches (196 mm)~~ **8 inches (203 mm)** below the top of the threshold.

Exception: A top landing is not required where a *stairway* of not more than ~~two~~ **three** *risers* is located on the exterior side of the door, provided that the door does not swing over the *stairway*.

R311.7 Stairways. Where required by this code or provided, *stairways* shall comply with this section.

Exceptions:

1. Stairways not within or serving a *regulated* building, *patio*, porch or deck.
2. Stairways leading to nonhabitable *attics*.
3. Stairways leading to *crawl spaces*.

R311.7.1 Width. *Stairways* shall be not less than 36 inches (914 mm) in clear width at all points above the permitted *handrail* height and below the required headroom height. The clear width of *stairways* at and below the *handrail* height, including treads and landings, shall be not less than 31½ inches (787 mm) where a *handrail* is installed on one side and 27 inches (698 mm) where *handrails* are installed on both sides.

Exceptions:

1. The width of *spiral stairways* shall be in accordance with Section R311.7.10.1.
2. Where a floor is served by more than one stairway, stairways other than the first stairway may have a clear width of not less than 30 inches (762 mm). Any handrail may encroach not more than 4½ inches (114 mm) into the clear width.

R311.7.5.1 Risers. The *riser* height shall be not more than ~~7¾ inches (196 mm)~~ 8 inches (203 mm). The *riser* height shall be measured vertically between leading edges of the adjacent treads. The greatest *riser* height within any flight of stairs shall not exceed the smallest by more than ¾ inch (9.5 mm). *Risers* shall be vertical or sloped from the underside of the *nosings* of the tread above at an angle not more than 30 degrees (0.51 rad) from the vertical. At open *risers*, openings located more than 30 inches (762 mm), as measured vertically, to the floor or *grade* below shall not permit the passage of a 4-inch-diameter (102 mm) sphere.

[The exceptions remain unchanged.]

R311.7.5.2 Treads. The tread depth shall be not less than ~~10 inches (254 mm)~~ 9 inches (229 mm). The tread depth shall be measured horizontally between the vertical planes of the foremost projection of adjacent treads and at a right angle to the tread's leading edge. The greatest tread depth within any flight of stairs shall not exceed the smallest by more than ¾ inch (9.5 mm).

R311.7.5.2.1 Winder treads. *Winder* treads shall have a tread depth of not less than ~~10 inches (254 mm)~~ 9 inches (229 mm) measured between the vertical planes of the foremost projection of adjacent treads at the intersections with the walkline.

[The rest of this section remains unchanged.]

R311.7.5.3 Nosings. *Nosings* at treads, landings and floors of *stairways* shall have a radius of curvature at the *nosings* not greater than 9/16 inch (14 mm) or a bevel not greater than ½ inch (12.7 mm). A *nosings* projection not less than ¾ inch (19 mm) and not more than 1¼ inches (32 mm) shall be provided on *stairways*. The greatest *nosings* projection shall not exceed the smallest *nosings* projection by more than ¾ inch (9.5 mm) within a *stairway*.

Exception: A *nosings* projection is not required where the tread depth is not less than 10 inches (254mm) ~~11 inches (279 mm)~~.

R311.7.5.5 Slope. Where the bottom or top riser of a stairway adjoins a sloping walk, garage floor or driveway, the bottom or top riser is permitted to be reduced along the slope, with the variation in height of the bottom or top riser not to exceed 3 inches (76 mm) in every 36 inches (914 mm) of walk or stairway width.

R311.7.7 Stairway walking surface. The walking surface of treads and landings of *stairways* shall be sloped not steeper than 1 unit vertical in 48 units horizontal (2-percent slope).

Exception: Where the surface of an exterior landing is required elsewhere in the code to drain surface water, the walking surface of the landing shall be sloped not steeper than 1 unit vertical in 20 units horizontal (5-percent slope) in the direction of travel.

**Section R311.7.7
Model code changes:**

A new exception has been added allowing steeper slopes for exterior landings that also serve to drain surface water away from the building.

R311.7.8 Handrails. *Handrails* shall be provided on not less than one side of each flight of stairs with four or more *risers*. The handrail required for winders shall be located on the side of the stairway where the treads are narrower.

R311.7.8.1 Height. *Handrail* height, measured vertically from the sloped plane adjoining the tread *nosings*, or finish surface of ramp slope, shall be not less than ~~34 inches (864 mm)~~ 30 inches (762 mm) and not more than 38 inches (965 mm).

Exceptions:

[Exceptions 1 and 2 remain unchanged]

3. Where a handrail is incorporated as the top of a guard, the height shall be not less than 34 inches (864 mm) and not more than 38 inches (965 mm) as measured vertically from a line connecting the leading edges of the treads.

R311.7.11 Alternating tread devices. Alternating tread devices shall not be used as an element of a means of egress. Alternating tread devices shall be permitted provided that a required means of egress *stairway* or *ramp* serves the same space at each adjoining level or where a means of egress is not required. The clear width at and below the *handrails* shall be not less than 20 inches (508 mm).

~~**Exception:** Alternating tread devices are allowed to be used as an element of a means of egress for lofts, *mezzanines* and similar areas of 200 gross square feet (18.6 m²) or less where such devices do not provide exclusive access to a kitchen or bathroom.~~

R311.7.12 Ship's ladders. Ship's ladders shall not be used as an element of a means of egress. Ship's ladders shall be permitted provided that a required means of egress *stairway* or *ramp* serves the same space at each adjoining level or where a means of egress is not required. The clear width at and below the *handrails* shall be not less than 20 inches (508 mm).

~~**Exception:** Ship's ladders are allowed to be used as an element of a means of egress for lofts, *mezzanines* and similar areas of 200 gross square feet (18.6 m²) or less that do not provide exclusive access to a kitchen or bathroom.~~

R311.8 Ramps. Where required by this code or provided, *ramps* shall comply with this section.

Exception: Ramps not within or serving a regulated building, patio, porch or deck.

SECTION R312 GUARDS AND WINDOW FALL PROTECTION

R312.1.3 Opening limitations. Required *guards* shall not have openings from the walking surface to the required *guard* height that allow passage of a sphere 4 inches (102 mm) in diameter.

Exceptions:

1. The triangular openings at the open side of *stair*, formed by the *riser*, tread and bottom rail of a *guard*, shall not allow passage of a sphere 6 inches (152 mm) in diameter.
2. *Guards* on the open side of stairs shall not have openings that allow passage of a sphere ~~4³/₈ inches (111 mm)~~ 5 inches (127 mm) in diameter. Opening limitations for required guards on open sides of stairways are applicable above the second riser of the stair.

R312.2.1 Window opening height. In *dwelling units*, where the **bottom** of the **clear opening** of an operable window opening is located less than 24 inches (610 mm) above the finished floor and greater than 72 inches (1829 mm) above the finished *grade* or other flat surface not less than 36 inches (914 mm) in width below on the exterior of the building, the operable window shall comply with one of the following:

1. Operable window openings will not allow a 4-inch-diameter (102 mm) sphere to pass through where the openings are in their largest opened position.
2. Operable windows are provided with window **opening control devices** or fall prevention devices that comply with ASTM F2090.

R312.2.1

Model code changes:

The model code clarified that measurements for determining the need for fall protection are taken to the bottom of the clear opening of the window.

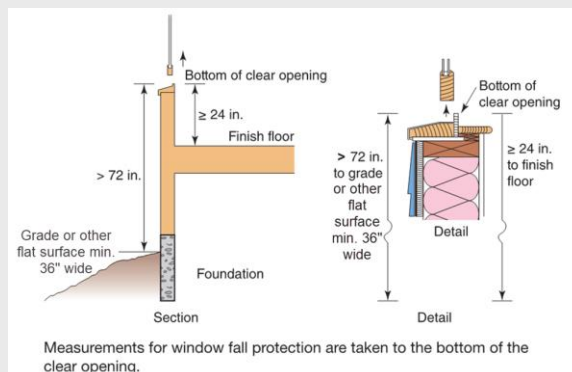

SECTION R313 AUTOMATIC FIRE SPRINKLER SYSTEMS

[This section is not adopted by the State of Oregon, Building Codes Division, as part of this code.](#)

IRC R313.1 Townhouse automatic fire sprinkler systems. ...*Not adopted.*

IRC R313.1.1 Design and installation. ...*Not adopted.*

IRC R313.2 One- and two-family dwellings automatic sprinkler systems. ...*Not adopted.*

IRC R313.2.1 Design and installation. ...*Not adopted.*

SECTION R314 SMOKE ALARMS

R314.3 Location. Smoke alarms shall be installed in the following locations:

1. In each sleeping room.
2. Outside each separate sleeping area, [within 21 feet \(6400 mm\) of any door to a sleeping room, measured along a path of travel](#) ~~in the immediate vicinity of the bedrooms.~~
3. On each additional story of the *dwelling*, including *basements* and *habitable attics* and not including crawl spaces and uninhabitable *attics*. In *dwellings* or *dwelling units* with split levels and without an intervening door between the adjacent levels, a smoke alarm installed on the upper level shall suffice for the adjacent lower level provided that the lower level is less than one full *story* below the upper level.
4. Not less than 3 feet (914 mm) horizontally from the door or opening of a bathroom that contains a bathtub or shower unless this would prevent placement of a smoke alarm required by this section.
5. [In the hallway and in the room open to the hallway in *dwelling units* where the ceiling height of a room open to a hallway serving ~~bedrooms~~ \[sleeping rooms\]\(#\) exceeds that of the hallway by 24 inches \(610 mm\) or more.](#)

Section R314.3 Model code change

- A new location requirement for smoke alarms has been added.
- A new requirement for smoke alarm in raised ceiling areas open to hallways has been added.
- New requirements for smoke alarms installed near permanently installed cooking appliances have been added.

R314.3.1 Installation near cooking appliances. Smoke alarms shall not be installed in the following locations unless this would prevent placement of a smoke alarm in a location required by Section R314.3.

1. Ionization smoke alarms shall not be installed less than 20 feet (6096 mm) horizontally from a permanently installed cooking *appliance*.
2. Ionization smoke alarms with an alarm-silencing switch shall not be installed less than 10 feet (3048 mm) horizontally from a permanently installed cooking *appliance*.
3. Photoelectric smoke alarms shall not be installed less than 6 feet (1828 mm) horizontally from a permanently installed cooking *appliance*.
4. [Smoke alarms *listed* and marked “helps reduce cooking nuisance alarms” shall not be installed less than 6 feet \(1828 mm\) horizontally from a permanently installed cooking *appliance*.](#)

R314.4 Interconnection. Where more than one smoke alarm is required to be installed within an individual *dwelling unit* in accordance with Section R314.3, the alarm devices shall be interconnected in such a manner that the actuation of one alarm will activate all of the alarms in the individual *dwelling unit*. Physical interconnection of smoke alarms shall not be required where *listed* wireless alarms are installed and all alarms sound upon activation of one alarm.

[Exception: Hardwired interconnection of smoke alarms in existing areas shall not be required where *alterations or repairs* do not result in removal of interior wall or ceiling finishes exposing the structure.](#)

SECTION R315 CARBON MONOXIDE ALARMS

R315.1 General. Carbon monoxide alarms shall comply with Section R315.

R315.1.1 Listings. Carbon monoxide alarms shall be *listed* in accordance with UL 2034. Combination carbon monoxide and smoke alarms shall be *listed* in accordance with UL 217 and UL 2034.

ORS 479.250 through 479.300 are statutes relating to smoke alarms and are under the enforcement authority of the State Fire Marshal's Office.

ORS 479.297 is not part of this code but is reprinted here for the reader's convenience.

ORS 479.297 Smoke alarms; required equipment; exemptions.

(1) All ionization smoke alarms sold in this state that are solely battery-operated shall be packaged with a 10-year battery.

(2) All ionization smoke alarms sold in this state shall include a "hush" mechanism that allows a person to temporarily disengage the alarm for a period of not more than 15 minutes.

(3) The provisions of this section do not apply to:

(a) Smoke alarms specifically designed for persons who are hard of hearing;

(b) Smoke alarms sold in this state for shipment out of state; or

(c) Smoke alarms sold for installation in recreational vehicles, commercial vehicles, railroad equipment, aircraft, marine vessels or manufactured dwellings.

(4) The sale of a recreational vehicle, commercial vehicle, railroad equipment, aircraft, marine vessel or new manufactured dwelling containing a smoke alarm does not constitute sale of a smoke alarm.

R315.2.1 New construction. For new construction, carbon monoxide alarms shall be provided in *dwelling units* ~~where either or both of the following conditions exist:~~

- ~~1. The dwelling unit contains a fuel-fired appliance.~~
- ~~2. The dwelling unit has an attached garage with an opening that communicates with the dwelling unit.~~

IRC R315.2.2 Alterations, repairs and additions. ...*Not adopted.*

R315.2.2 Existing dwellings. Where a new carbon monoxide source is introduced or work requiring a structural permit occurs in existing dwellings, carbon monoxide alarms shall be provided in accordance with this section.

Exception: Work involving the exterior surfaces of dwellings, such as the replacement of roofing or siding, or the addition or replacement of windows or doors, or the addition of a porch or deck, are exempt from the requirements of this section.

R315.3 Location. ~~Carbon monoxide alarms in dwelling units shall be installed outside of each separate sleeping area in the immediate vicinity of the bedrooms.~~ Carbon monoxide alarms shall be located in each sleeping room or within 15 feet (4572 mm) outside of each sleeping room door. Sleeping rooms on separate floor levels in a structure consisting of two or more stories shall have separate carbon monoxide alarms serving each story. Where a fuel-burning *appliance* is located within a ~~bedroom~~ sleeping room or its attached bathroom, a carbon monoxide alarm shall be installed within the ~~bedroom~~ sleeping room.

R315.5 Interconnectivity. Where more than one carbon monoxide alarm is required to be installed within an individual *dwelling unit* in accordance with Section R315.3, the alarm devices shall be interconnected in such a manner that the actuation of one alarm will activate all of the alarms in the individual *dwelling unit*. Physical interconnection of carbon monoxide alarms shall not be required where *listed* wireless alarms are installed and all alarms sound upon activation of one alarm.

Exception: Interconnection of carbon monoxide alarms in existing areas shall not be required where *alterations* or *repairs* do not result in removal of interior wall or ceiling finishes exposing the structure, ~~unless there is an attic, crawl space or basement available that could provide access for interconnection without the removal of interior finishes.~~

R315.6 Power source. Carbon monoxide alarms shall receive their primary power from the building wiring where such wiring is served from a commercial source and, where primary power is interrupted, shall receive power from a battery. Wiring shall be permanent and without a disconnecting switch other than those required for overcurrent protection.

Exceptions:

[Exceptions 1 and 2 remain unchanged]

3. Interconnection and hardwiring of combination smoke/carbon monoxide alarms in existing areas shall not be required where the alterations or repairs do not result in the removal of interior wall or ceiling finishes exposing the structure.

SECTION R316 PLASTIC

R316.1 Foam plastics. The provisions of this section shall govern the materials, design, application, construction and installation of foam plastic materials.

IRC R316.7 Termite damage.*Not adopted.*

R316.7 R316.8-Wind resistance. Foam plastic insulation complying with ASTM C578 and ASTM C1289 and used as exterior wall sheathing on framed wall assemblies shall comply with SBCA FS 100 for wind pressure resistance unless installed directly over a sheathing material that is separately capable of resisting the wind load or otherwise exempted from the scope of SBCA FS 100.

R316.8 Plastic panels and panel systems. The provisions of this section shall be limited to detached one- and two-family dwellings and shall govern the quality, methods and expanded use of plastic panels and panel systems classified as CC-1 plastics in accordance with ASTM D635 and this section. Plastic panels and panel systems installed in detached one- and two-family dwellings and meeting the requirements of this section may be of unlimited area.

R316.8.1 Approval for use. The building official may require that sufficient technical data be submitted to substantiate that the proposed plastic material is satisfactory for the intended use.

R316.8.1.1 Identification. Each unit or package of plastic panels and panel systems shall be identified with a mark or decal satisfactory to the building official that includes identification as to the material classification.

R316.8.1.2 Standards of quality. The standards listed here are listed in Chapter 43 of this code.

1. ASTM D635.
2. ASTM D1929.
3. ASTM D2843.
4. NFPA 285.
5. UL 790.
6. Factory Mutual Research Corporation (FMRC) Approval Standard 4470, Section 5.5 for Foot Traffic.
7. Factory Mutual Research Corporation (FMRC) Approval Standard 4471 for the Test Method for Wind Uplift.
8. Factory Mutual Research Corporation (FMRC) Approval Standard 4880, Section 5.4, 25-Foot and 50-Foot High Corner Tests.

R316.8.2 Definitions.

PLASTIC PANEL. As used in this section, classified as CC-1 in accordance with ASTM D635.

PLASTIC PANEL SYSTEM. Construction in whole or in part of plastic panels and component structural parts that create a wall or roof panel capable of supporting the appropriate design loads for the building element.

WALL PANELS. As used in this section, approved plastic materials that are not classified as plastic glazing and are used as an element of wall construction.

R316.8.3 Design and installation structural requirements. Plastic materials and their assembly shall be of adequate strength and durability to withstand the design loads as prescribed elsewhere in this code. Technical data shall be submitted to establish stresses, maximum unsupported spans and such other information for the various thicknesses and forms used as may be deemed necessary by the building official.

R316.8.3.1 Fastening. Fastening shall be adequate to withstand design loads as prescribed elsewhere in this code. Proper allowance shall be made for expansion and contraction of plastic materials to protect the structural integrity of the installation in accordance with accepted data on coefficient of expansion of the material and other material in conjunction with which it is employed. Listed assemblies shall be installed according to manufacturers' specifications. Corrosion-resistant or other approved fastening systems shall be used.

R316.8.3.2 Water resistance. Plastic panels and panel systems shall resist water penetration and provide weather protection for the building.

R316.8.4 Wall panels and panel systems. Approved plastic panels and panel systems may be installed in exterior walls, provided that the walls are not required to have a fire-resistance rating.

Exception: Plastic panels approved as fire-resistance-rated construction or as a fire assembly.

For fire-resistance-rated protection of exterior walls and openings, as determined by location on lot, see Section R302.

R316.8.5 Roof panels and panel systems. Approved plastic roof panels and plastic panel systems may be installed in roofs of buildings not required to have a fire-resistance rating. Roof panels or units shall not be installed within that portion of a roof located within a distance to lot line or public way where openings in exterior walls are prohibited or required to be protected.

Exception: Plastic panels approved as fire-resistance-rated construction or as a fire assembly.

Plastic roof panels and panel systems shall not have a slope less than 2 units vertical in 12 units horizontal. Where used as roof covering, the panels or panel systems shall have a Class C rating or greater.

R316.9 Plastic composites. Plastic composite exterior deck boards, stair treads, guards and handrails shall comply with the requirements of Section R507.2.2.

SECTION R317 PROTECTION OF WOOD & WOOD-BASED PRODUCTS AGAINST DECAY

R317.1 Location required. Protection of wood and wood-based products from decay shall be provided in the following locations by the use of *naturally durable wood* or wood that is preservative-treated in accordance with AWPA U1.

1. In crawl spaces or unexcavated areas located within the periphery of the building foundation, wood joists or the bottom of a wood structural floor where closer than 18 inches (457 mm) to exposed ground, wood girders where closer than 12 inches (305 mm) to exposed ground, **and wood columns where closer than 8 inches (204 mm) to exposed ground.**
2. Wood framing members, **including columns, that rest directly on and sill plates in contact with** concrete or masonry ~~exterior~~ foundation walls ~~and are less than 8 inches (203 mm) from the exposed ground.~~
3. Sills and sleepers on a concrete or masonry slab that is in direct contact with the ground unless separated from such slab by an impervious moisture barrier such as 6-mil-thick (0.15 mm) polyethylene sheeting or equivalent.

[Items 4 through 7 remain unchanged.]

8. Portions of wood structural members that form the structural supports of buildings, ~~decks,~~ balconies, porches or similar permanent building appurtenances where those members are exposed to the weather without ~~adequate~~ protection from a roof, eave, overhang or other covering that ~~would~~ prevent moisture or water accumulation on the surface or at joints between members.

Exception: Sawn lumber used in ~~structures, buildings~~ located in a geographical region where documented experience has demonstrated that climatic conditions preclude the need to use naturally durable or preservative-treated wood where the structure is exposed to the weather.

9. Wood columns in contact with *basement* floor slabs unless supported by concrete piers or metal pedestals projecting not less than 1 inch (25 mm) above the concrete floor and separated from the concrete pier by an impervious moisture barrier such as 6-mil-thick (0.15 mm) polyethylene sheeting or equivalent.
-

SECTION R318 PROTECTION AGAINST SUBTERRANEAN TERMITES

All of IRC Section R318 is not adopted.

SECTION R318 MOISTURE CONTROL

R318.1 Vapor retarders. In all framed walls, floors and roof/ceilings that are elements of the building thermal envelope, a Class II vapor retarder shall be installed on the warm-in-winter side of the insulation.

Exceptions:

1. In construction where moisture or freezing will not damage the materials.
2. Where the framed cavity or space is ventilated to allow moisture to escape.
3. Class III vapor retarders shall be permitted for framed walls where either of the following conditions apply:
 - 3.1. Vented cladding is installed over wood structural panels.
 - 3.2. Continuous air impermeable insulation is applied on exterior above-grade wall surfaces.

R318.2 Moisture content. Prior to the installation of interior finishes, the building official shall be notified by the general contractor in an approved manner that all moisture-sensitive wood framing members used in construction have a moisture content of not more than 19 percent of the weight of dry wood framing members.

SECTION R319 SITE ADDRESS

R319.1 Address identification. Buildings shall be provided with *approved* address identification. The address identification shall be legible and placed in a position that is visible from the street or road fronting the property. Address identification characters shall contrast with their background. ~~Address numbers shall be Arabic numbers or alphabetical letters. Numbers shall not be spelled out. Each character shall be not less than 4 inches (102 mm) in height with a stroke width of not less than 0.5 inch (12.7 mm). Where required by the fire code official, address identification shall be provided in additional approved locations to facilitate emergency response.~~ Where access is by means of a private road and the building address cannot be viewed from the *public way*, a monument, pole or other sign or means shall be used to identify the structure. ~~Address identification shall be maintained.~~

SECTION R320 ACCESSIBILITY

R320.1 Scope. *Dwelling units required to be accessible by ORS 447.231 shall comply with Chapter 11 of the Building Code as applicable.* ~~Where there are four or more dwelling units or sleeping units in a single structure, the provisions of Chapter 11 of the International Building Code for Group R-3 shall apply.~~

~~**Exception:** Owner-occupied lodging houses with five or fewer guestrooms are not required to be accessible.~~

Section R320.2 Model code change:

A new section has been added clarifying the accessibility requirements for live/work units.

R320.2 Live/work units. In *live/work units*, the nonresidential portion shall be accessible in accordance with Sections 508.5.9 and 508.5.11 of the *Building Code*. In a structure where there are four or more *live/work units*, the dwelling portion of the *live/work unit* shall comply with Section 1108.6.2.1 of the *Building Code*.

SECTION R321 ELEVATORS AND PLATFORM LIFTS

R321.1 Elevators. Where provided, passenger elevators, limited-use and limited-application elevators or private residence elevators ~~shall comply with ASME A17.1/CSA B44~~ and their components shall comply with the *Elevator Code*.

R321.2 Platform lifts. Where provided, platform lifts ~~shall comply with ASME A18.1~~ and their components shall comply with the *Elevator Code*.

R321.3 Accessibility. Elevators or platform lifts ~~that are part of an accessible route required by~~ in covered multifamily dwellings shall comply with Chapter 11 of the *Building Code*, ~~shall comply with ICC A117.1.~~

SECTION R322 FLOOD-RESISTANT CONSTRUCTION

R322.1 General. Buildings and structures constructed in whole or in part in flood hazard areas, including A or V Zones and Coastal A Zones, as established by the flood plain administrator ~~in Table R301.2~~, and substantial improvement and *repair* of substantial damage of buildings and structures in flood hazard areas, shall be designed and constructed in accordance with the provisions contained in this section. *[The rest of this section remains unchanged.]*

R322.1.2 Structural systems. Structural systems of buildings and structures shall be designed, connected and anchored to resist flotation, collapse or permanent lateral movement ~~due to structural~~ resulting from hydrodynamic and hydrostatic loads and stresses, ~~including from flooding equal to the design flood elevation~~ effects of buoyancy.

R322.1.3 Flood-resistant construction. Buildings and structures erected in areas prone to flooding, as established by the flood plain administrator, shall be constructed by methods and practices that minimize flood damage.

R322.1.4 Establishing the design flood elevation. The design flood elevation shall be established by the flood plain administrator, used to define flood hazard areas. ~~At a minimum, the design flood elevation shall be the higher of the following:~~

- ~~1. The base flood elevation at the depth of peak elevation of flooding, including wave height, that has a 1 percent (100 year flood) or greater chance of being equaled or exceeded in any given year.~~
- ~~2. The elevation of the design flood associated with the area designated on a flood hazard map adopted by the community, or otherwise legally designated.~~

IRC R322.1.4.1 Determination of design flood elevations. ...*Not adopted.*

IRC R322.1.4.2 Determination of impacts. ...*Not adopted.*

R322.1.6 Protection of mechanical, plumbing and electrical systems. Electrical systems, *equipment* and components; heating, ventilating, air-conditioning; plumbing *appliances* and plumbing fixtures; *duct systems*; and other service *equipment* shall be located at or above the elevation required by the flood plain administrator in Section R322.2 or R322.3. If replaced as part of a substantial improvement as established by the flood plain administrator, electrical systems, *equipment* and components; heating, ventilating, air-conditioning and plumbing *appliances* and plumbing fixtures; *duct systems*; and other service *equipment* shall meet the requirements of this section. Systems, fixtures, and *equipment* and components shall not be mounted on or penetrate through walls intended to break away under flood loads.

Exception: Locating electrical systems, *equipment* and components; heating, ventilating, air-conditioning; plumbing *appliances* and plumbing fixtures; *duct systems*; and other service *equipment* is permitted below the elevation required by the flood plain administrator in Section R322.2 or R322.3 provided that they are designed and installed to prevent water from entering or accumulating within the components and to resist hydrostatic and hydrodynamic loads and stresses, including the effects of buoyancy, during the occurrence of flooding to the required elevation in accordance with ASCE 24. [*The rest of this section remains unchanged.*]

R322.1.7 Protection of water supply and sanitary sewage systems. New and replacement water supply systems shall ~~be designed to~~ minimize or eliminate infiltration of flood waters into the systems in accordance with the plumbing provisions of this code. New and replacement sanitary sewage systems shall ~~be designed to~~ minimize or eliminate infiltration of floodwaters into systems and discharges from systems into floodwaters in accordance with the Plumbing Code ~~plumbing provisions of this code and Chapter 3 of the International Private Sewage Disposal Code.~~

R322.1.8 Flood-resistant materials. Building materials and installation methods used for flooring and interior and *exterior walls* and wall coverings below the elevation required by the flood plain administrator in Section R322.2 or R322.3 shall be flood damage-resistant materials that conform to the provisions of FEMA TB-2.

IRC R322.1.9 Manufactured homes. ...*Not adopted.*

IRC R322.1.10 As-built elevation documentation. ...*Not adopted.*

R322.2 Flood hazard areas (including A Zones). Areas that have been determined by the flood plain administrator to be prone to flooding and that are not subject to high-velocity wave action shall be designated as flood hazard areas. Flood hazard areas that have been delineated as subject to wave heights between 1½ feet (457 mm) and 3 feet (914 mm) or otherwise designated by the *jurisdiction* shall be designated as Coastal A Zones and are subject to the requirements of Section R322.3. Buildings and structures constructed in whole or in part in flood hazard areas shall be designed and constructed in accordance with Sections R322.2.1 through R322.2.4.

R322.2.1 Elevation requirements. Required elevations shall be determined by the flood plain administrator. [*The rest of this section is not adopted and is deleted.*]

R322.2.2 Enclosed area below required elevation. Enclosed areas, including *crawl spaces*, that are below the elevation as established by the flood plain administrator, ~~required in Section R322.2.1~~ shall:

1. Be used solely for parking of vehicles, building access or storage.
 2. Be provided with flood openings that meet the following criteria and are installed in accordance with Section R322.2.2.1:
 - 2.1. The total net area of ~~nonengineered~~ openings shall be not less than 1 square inch (645 mm²) for each square foot (0.093 m²) of enclosed area where the enclosed area is measured on the exterior of the enclosure walls, or the openings shall be designed as engineered openings in accordance with Section R301.1.3 and the *construction documents* shall include a statement ~~by a registered design professional~~ that the design of the openings will provide for equalization of hydrostatic flood forces on *exterior walls* by allowing for the automatic entry and exit of floodwaters as specified in Section 2.7.2.2 of ASCE 24. [*2.2 and 2.3 remain unchanged.*]
-

R322.2.4 Tanks. See Section R101.2 for the scope of regulated tanks. ~~Underground tanks shall be anchored to prevent flotation, collapse and lateral movement under conditions of the base flood.~~ Above-ground tanks shall be installed at or above the elevation required in Section R322.2.1 or shall be anchored to prevent flotation, collapse and lateral movement under conditions of the base flood.

R322.3 Coastal high-hazard areas (including V Zones and Coastal A Zones, where designated). Areas that have been determined by the flood plain administrator to be subject to wave heights in excess of 3 feet (914 mm) or subject to high-velocity wave action or wave-induced erosion shall be designated as coastal high-hazard areas. Flood hazard areas that have been designated as subject to wave heights between 1½ feet (457 mm) and 3 feet (914 mm) or otherwise designated by the *jurisdiction* shall be designated as Coastal A Zones. Buildings and structures constructed in whole or in part in coastal high-hazard areas and Coastal A Zones, where designated, shall be designed and constructed in accordance with Sections R322.3.1 through R322.3.9.

R322.3.1 Location and site preparation.

1. New buildings and buildings that are determined by the flood plain administrator to be substantially improved pursuant to Section R105.3.1.1 shall be located landward of the reach of mean high tide.
 2. For any alteration of sand dunes and mangrove stands, the *building official* shall require submission of an ~~engineering approved~~ analysis that demonstrates that the proposed alteration will not increase the potential for flood damage.
-

R322.3.2 Elevation requirements.

1. Buildings and structures erected within coastal high-hazard areas and Coastal A Zones, as established by the flood plain administrator, shall be elevated so that the bottom of the lowest horizontal structural members supporting the lowest floor, with the exception of piling, pile caps, columns, grade beams and bracing, is elevated to or above the base flood elevation plus 1 foot (305 mm) or the design flood elevation, whichever is higher.
 2. *Basement* floors that are below *grade* on all sides are prohibited.
 3. ~~Garages used solely for parking, building access or storage, and carports shall comply with Item 1 or shall be at or above grade on not less than one side and, if enclosed with walls, such walls shall comply with Item 6.~~
 4. The use of fill for structural support is prohibited.
 5. Minor grading, and the placement of minor quantities of fill, shall be permitted for landscaping and for drainage purposes under and around buildings and for support of parking slabs, pool decks, patios and walkways.
 6. Walls and partitions enclosing areas below the elevation required in this section shall meet the requirements of Sections R322.3.4 and R322.3.5.
-

R322.3.3 Foundations. Buildings and structures erected in coastal high-hazard areas and Coastal A Zones, as established by the flood plain administrator, shall be supported on pilings or columns and shall be adequately anchored to such pilings or columns and shall comply with the following:

1. The space below the elevated building shall be either free of obstruction or, if enclosed with walls, the walls shall meet the requirements of Section R322.3.4.
2. Pilings shall have adequate soil penetrations to resist the combined wave and wind loads (lateral and uplift) and pile embedment shall include consideration of decreased resistance capacity caused by scour of soil strata surrounding the piling.
3. ~~Columns and their supporting foundations shall be designed to resist combined wave and wind loads, lateral and uplift, and shall include consideration of decreased resistance capacity caused by scour of soil strata surrounding the columns. Spread footing, mat, raft or other foundations that support columns shall not be permitted where soil investigations that are required in accordance with Section R401.4 indicate that soil material under the spread footing, mat, raft or other foundation is subject to scour or erosion from wave-velocity flow conditions. If permitted, spread footing, mat, raft or other foundations that support columns shall be designed in accordance with ASCE 24.~~
4. ~~Flood and wave loads shall be those associated with the design flood. Wind loads shall be those required by this code.~~
5. ~~Foundation designs and construction documents shall be prepared and sealed in accordance with Section R322.3.8.~~

Exception: In Coastal A Zones, as established by the flood plain administrator, stem wall foundations supporting a floor system above and backfilled with soil or gravel to the underside of the floor system shall be permitted provided that the foundations are designed to account for wave action, debris impact, erosion and local scour. Where soils are susceptible to erosion and local scour, stem wall foundations shall have deep footings to account for the loss of soil.

IRC R322.3.4 Concrete slabs. ...*Not adopted*

R322.3.4 Walls below required elevation. Walls and partitions are permitted below the elevation required in Section R322.3.2, provided that such walls and partitions are not part of the structural support of the building or structure and:

[1 through 3 and 5 remain unchanged.]

4. Where wind loading values of this code exceed 20 pounds per square foot (958 Pa), as determined in accordance with Section R301.1.3 using allowable stress design, the *construction documents* shall include documentation ~~prepared and sealed by a registered design professional~~ that:

[4.1 through 4.2 remain unchanged]

R322.3.5 Enclosed areas below required elevation. Enclosed areas ~~below~~ less than 1 foot (305 mm) above the elevation required in Section R322.3.2 shall be used solely for parking of vehicles, building access or storage.

R322.3.8 Construction documents. The *construction documents* shall include documentation that ~~is prepared and sealed by a registered design professional that~~ the design and methods of construction to be used meet the applicable criteria of this section.

R322.3.9 Tanks. See Section R101.2 for the scope of regulated tanks. ~~Underground tanks shall be anchored to prevent flotation, collapse and lateral movement under conditions of the base flood.~~ Above-ground tanks shall be installed at or above the elevation required in Section R322.3.2. Where elevated on platforms, the platforms shall be cantilevered from or knee braced to the building or shall be supported on foundations that conform to the requirements of Section R322.3.

SECTION R323 STORM SHELTERS

R323.1 General. This section applies to *storm shelters* where constructed as separate detached buildings or where constructed as safe rooms within buildings for the purpose of providing refuge from storms that produce high winds, such as tornados and hurricanes. In addition to other applicable requirements in this code, storm shelters shall be constructed in accordance with ICC 500.

IRC R323.1.1 Sealed documentation. ...*Not adopted.*

SECTION R324 SOLAR ENERGY SYSTEMS

R324.3.1 Equipment listings. *Photovoltaic panels* and modules shall be *listed* and *labeled* in accordance with UL 1703 or with both UL 61730-1 and UL 61730-2. Inverters shall be *listed* and *labeled* in accordance with UL 1741. ~~Systems connected to the utility grid shall use inverters listed for utility interaction. Mounting systems listed and labeled in accordance with UL 2703 shall be installed in accordance with the manufacturer's installation instructions and their listings.~~

Photovoltaic racking and associated attachment components shall comply with one of the following:

1. Certified to UL 1703 by a nationally recognized testing laboratory and installed in accordance with the *manufacturer's installation instructions.*
2. Designed by a *registered design professional.*
3. Field evaluation by an *approved field evaluation firm.*
4. Approval by the *building official.*

R324.3.1.1 Corrosion resistance. All components of the photovoltaic solar energy system exposed to the weather shall be constructed of approved corrosion-resistant materials.

Section R324.4

New / existing amendments:

The approved rooftop-mounted photovoltaic provisions from the OSSC have been added to the ORSC without any technical changes.

R324.4 Rooftop-mounted photovoltaic systems. Rooftop-mounted *photovoltaic panel systems* installed on or above the roof covering shall be designed and installed in accordance with this section.

R324.4.1 Structural requirements. Rooftop-mounted *photovoltaic panel systems* shall be designed to structurally support the system and withstand applicable gravity and wind loads in accordance with this section. The roof on which these systems are installed shall be designed and constructed to support the loads imposed by such systems in accordance with Chapter 8 or Section R301.1.3.

Exception: Prescriptive installations on existing roofs where the following criteria are met:

1. Structure requirements:
 - 1.1. The ground snow load does not exceed 70 psf (3.35 kN/m²).
 - 1.2. The wind exposure category is limited to Exposure Category B or C.
 - 1.3. Existing supporting roof framing is conventional light-frame construction with preengineered trusses or rafters spaced at not less than 24 inches (610 mm) on center.
 - 1.4. Existing rafters and ceiling joists comply with Sections R802.4.1, R802.5.1 and R802.5.2. Where rafter spans are based on purlins provided between the ridge and eave, such purlins shall be supported by braces to bearing partitions in accordance with Figure R324.4.1(1) and Section R802.4.5.
 - 1.5. Existing valley and hip rafters comply with Section R802.4.1 and are supported at the ridge by a brace to a bearing partition. Where roof rafters require purlins between the ridge and eave to comply with the rafter span tables, hip and valley rafters shall also be supported by a brace to a bearing partition.
 - 1.6. Where the existing grade and species of the rafters and ceiling joists cannot be verified, it shall be assumed to be No. 2 Grade Douglas Fir-Larch.
2. Roof materials: Roofing material shall be metal, single-layer wood shingle or shake, or not more than two layers of composition shingle.
3. Installation: Installation shall comply with Figure R324.4.1(2), R324.4.1(3) or Item 5, Exception 2.
4. Loading: The combined weight of the photovoltaic modules and racking shall not exceed 4.5 pounds per square foot (0.2155 kPa).
5. Attachments: Photovoltaic modules or racking shall be directly attached to the roof framing or blocking. Attachments shall be spaced not more than 48 inches (1219 mm) on center in any direction.

Exceptions:

 1. Attachments shall be spaced not more than 24 inches (610 mm) on center in any direction where any of the following conditions exist:
 - 1.1. The ground snow load p_g , exceeds 36 psf (1.724 kN/m²).
 - 1.2. The attachments are located within 3 feet (914 mm) of a roof edge, hip, eave or ridge.
 - 1.3. The basic design wind speed, V , exceeds 120 mph in wind Exposure Category B.
 - 1.4. The basic design wind speed, V , exceeds 110 mph in wind Exposure Category C.
 2. Photovoltaic modules or racking shall be permitted to be attached directly to standing seam metal panels using clamps and roofing materials where all of the following criteria are met:
 - 2.1. The allowable uplift capacity of clamps spaced greater than or equal to 48 inches (1219 mm) on center along a seam shall be not less than 115 pounds (52 kg). The allowable uplift capacity of clamps spaced less than 48 inches (1219 mm) on center along a seam shall be not less than 75 pounds (34 kg).
 - 2.2. Spacing of clamps along a seam shall be not less than 24 inches (610 mm) on center and not more than 60 inches (1524 mm) on center. Clamp spacing perpendicular to seams shall be such that the spacing measurement along a seam multiplied by the spacing measurement perpendicular to seams is not greater than 10 square feet (0.93 m²) in area.
 - 2.3. Roofing panels shall comply with all of the following:
 - 2.3.1. Shall be not less than a 26-gage steel.
 - 2.3.2. Shall be not more than 18 inches (457 mm) in width.
 - 2.3.3. Shall be attached with a minimum of #10 screws at 24 inches (610 mm) on center.

2.3.4. Shall be installed over minimum 1/2-inch (12.7 mm) nominal wood structural panels attached to framing with 8d nails at 6 inches (152 mm) on center at panel edges and 12 inches (305 mm) on center field nailing.

6. Height: Photovoltaic module height above roof shall be not more than 18 inches (457 mm) from the top of the photovoltaic module to the roof surface and shall be in accordance with Figure R324.4.1(2) or R324.4.1(3).

7. Submittal requirement: Construction documents shall not be required where the permit applicant has demonstrated on a form approved by the State of Oregon Building Codes Division, that the proposed installation complies with Section R324.6 and this section.

R324.4.1.1 Roof load. Portions of roof structures not covered with photovoltaic panel systems shall be designed for dead loads and roof loads in accordance with Sections R301.4 and R301.6), or in accordance with Section R301.1.3. Portions of roof structures covered with photovoltaic panel systems shall be designed for the following load cases:

1. dead load (including photovoltaic panel weight) plus snow load in accordance with Table R301.2.
2. Dead load (excluding photovoltaic panel weight) plus roof live load or snow load, whichever is greater, in accordance with Section R301.6.

R324.4.1.2 Wind load. Rooftop-mounted photovoltaic panel or module systems and their supports shall be designed and installed to resist the component and cladding loads specified in Table R301.2.1(1), adjusted for height and exposure in accordance with Table R301.2.1(2), or in accordance with Section R301.1.3.

R324.4.2 Fire classification. Rooftop-mounted photovoltaic panel systems shall have the same fire classification as the roof assembly required in Section R902.

R324.4.3 Roof penetrations. Roof penetrations shall be flashed and sealed in accordance with Chapter 9.

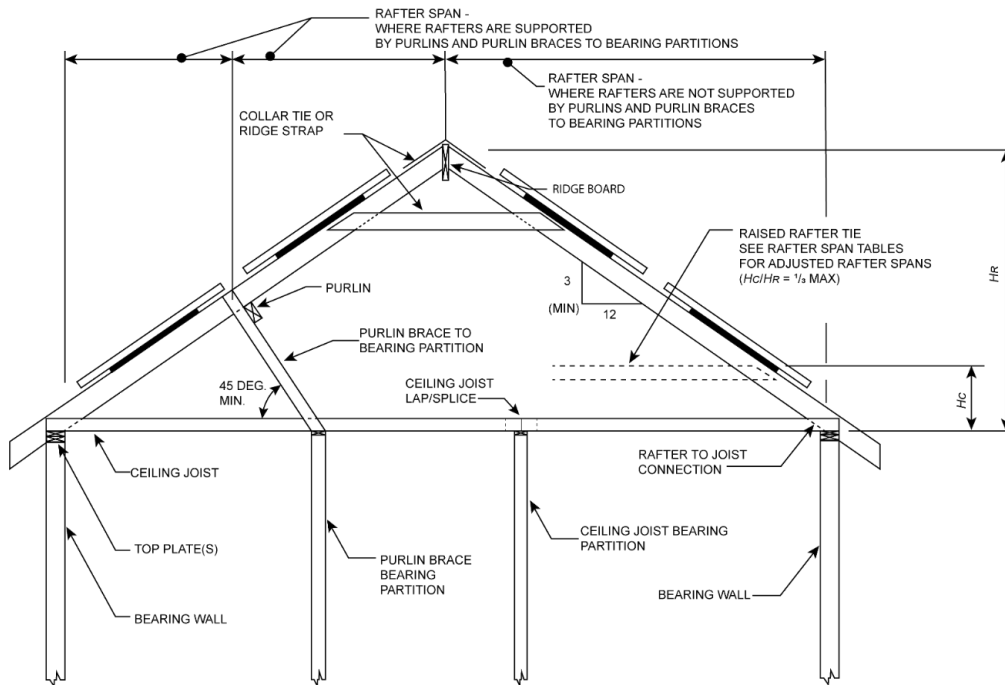

For SI: 1 inch = 25.4 mm, 1 foot = 305 mm, 1 degree = 0.018 rad.
 H_c = Height of ceiling joists or rafter ties measured vertically above the top of rafter support walls.
 H_r = Height of roof ridge measured vertically above the top of rafter support walls.

FIGURE R324.4.1(1)
BRACED ROOF RAFTERS FOR PRESCRIPTIVE ROOFTOP-MOUNTED PHOTOVOLTAIC PANEL SYSTEMS

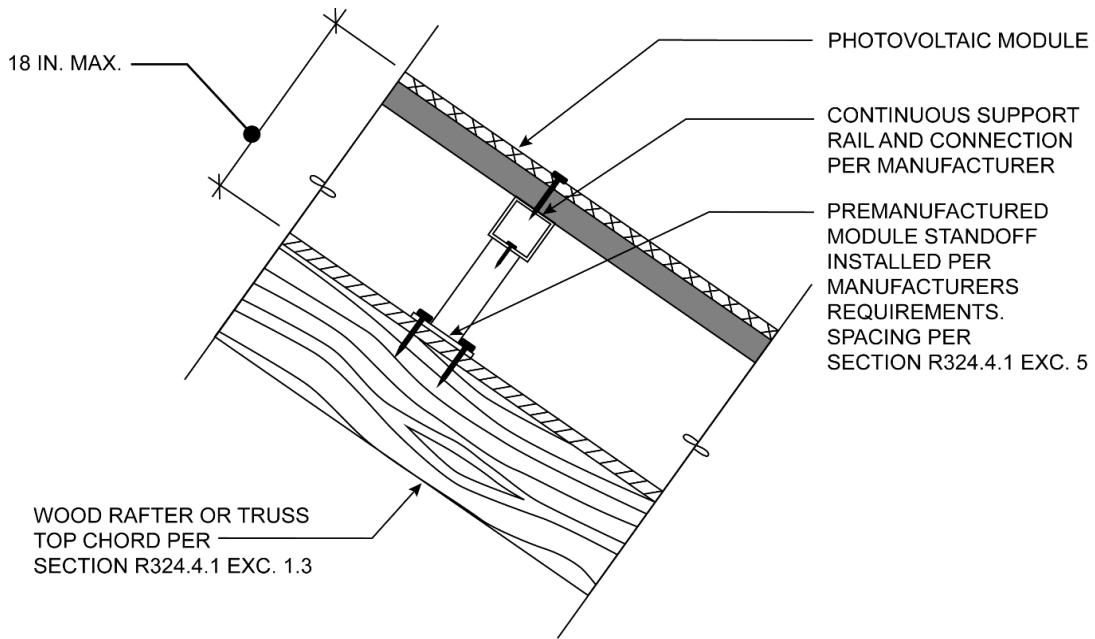

For SI: 1 inch = 25.4 mm.

FIGURE R324.4.1(2)
PRESCRIPTIVE PHOTOVOLTAIC RACKING AND MODULE ATTACHMENT TO RAFTERS OR TRUSSES

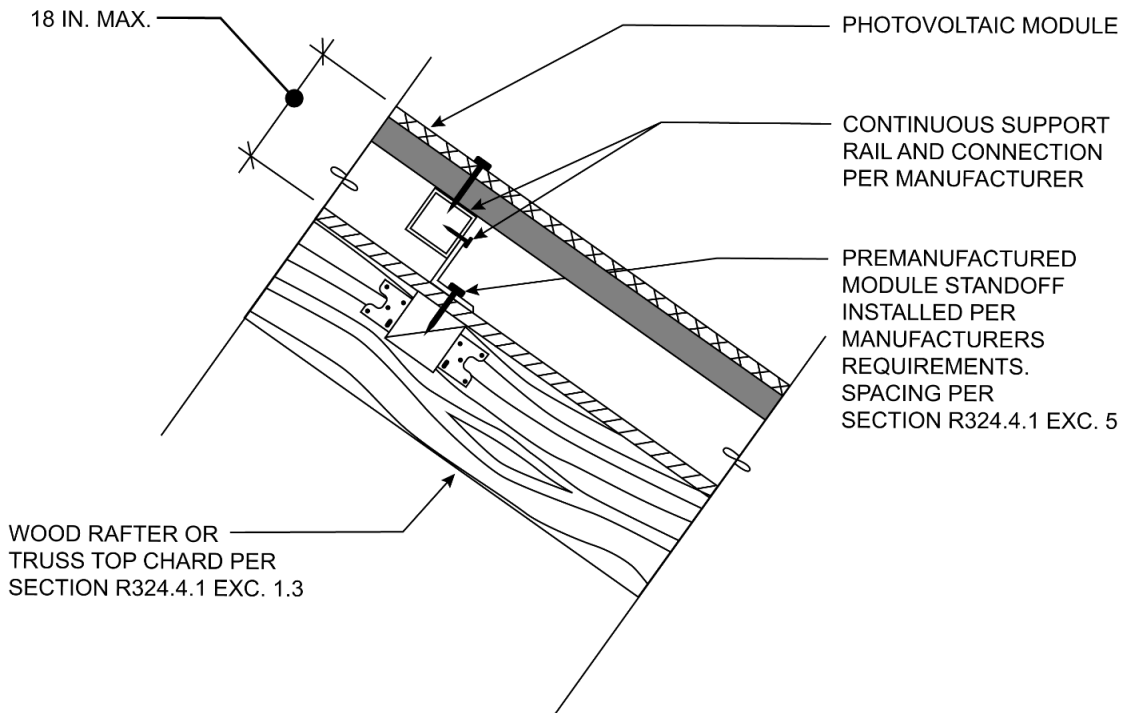

For SI: 1 inch = 25.4 mm.

FIGURE R324.4.1(3)
PRESCRIPTIVE PHOTOVOLTAIC RACKING AND MODULE ATTACHMENT TO BLOCKINGS

IRC R324.6 Roof access and pathways. ...Not adopted.

Section R324.6

New amendments:

The fire fighter access and escape pathway requirements have been clarified.

The division has issued a technical bulletin to provide technical guidance on the requirements as they apply to photovoltaic systems installed on detached one- and two-family dwellings and townhouses.

Oregon.gov/bcd/codes-stand/Documents/techb-solarpv-pathways.pdf



R324.6 Photovoltaic panel system location. The location of *photovoltaic* components, *racking*, support structures and attachments shall be in accordance with Sections R324.6.1 through R324.6.9.

R324.6.1 Zoning requirements. The installation of *photovoltaic panel systems* shall comply with the zoning requirements of the *municipality*.

R324.6.2 Flood hazard areas. The installation of *photovoltaic panel systems* within *flood hazard areas*, as established by the *flood plain administrator*, shall comply Section R322.

R324.6.3 Building egress. *Photovoltaic panel systems* shall not be installed in locations that would restrict or otherwise prevent the use of the required *means of egress* and *emergency escape and rescue openings*.

R324.6.4 Light and ventilation. *Photovoltaic panel systems* shall not be installed in locations that would restrict the required light or ventilation.

R324.6.5 Rooftop vent and drain clearances. *Photovoltaic panel systems* shall not be installed in locations that would restrict the function of plumbing or mechanical vents, skylights, drains or other rooftop features.

R324.6.6 Mechanical equipment clearances. *Photovoltaic panel systems* shall be installed with a clearance of not less than 30 inches (762 mm) around mechanical equipment requiring service or maintenance. The applicable mechanical provisions of this code apply to installations of *photovoltaic panel systems*.

R324.6.7 Roof drainage. *Photovoltaic panel systems* shall not be installed in a manner that would obstruct roof drainage. Vertical *supports* or roof penetrations are not permitted within 12 inches (305 mm) of each side of the low point of the valley. The *photovoltaic modules* or *racking* are permitted to extend into the valley not more than 6 inches (152 mm) from the valley low point where a clearance of not less than 3 inches (76 mm) above the surface of the roof is provided.

R324.6.8 Fire fighter access and escape. To provide access and escape for fire fighters, the location of rooftop-mounted *photovoltaic modules* shall comply with the requirements of Section R324.6.8.1 through R324.6.8.4.

R324.6.8.1 Pathway requirements. All *photovoltaic* installations shall be provided with *pathways* not less than 36 inches (914 mm) in width along not less than three sides of the *solar roof plane*. The bottom edge of a roof plane with a slope greater than 2 units vertical in 12 units horizontal (2:12) shall not be used as a *pathway*. All *pathways* shall be located over a structurally supported area and measured from the edge of the roof and horizontal ridge to the *photovoltaic array* or any portion thereof.

Exceptions:

1. Structures with a *photovoltaic array* area of 1,000 square feet (92.9 m²) or less installed on a roof with a slope greater than 2 units vertical in 12 units horizontal (2:12) with an intersecting *adjacent roof plane* and where no dimension of the array is greater than 150 feet (45,720 mm) in length or width:
 - 1.1. Where the *photovoltaic array* does not exceed 25 percent, measured in plan view, of the total roof area of the structure, an unobstructed *pathway* not less than 12 inches (305 mm) shall be provided along each side of any horizontal ridge.
 - 1.2. Where the *photovoltaic array* exceeds 25 percent, measured in plan view, of the total roof area of the structure, an unobstructed *pathway* not less than 36 inches (914 mm) from ridge to eave over a structurally supported area shall be provided in addition to an unobstructed *pathway* not less than 12 inches (305 mm) along each side of any horizontal ridge.
2. *Pathways* are not required on nonhabitable *accessory structures*, provided that they are separated from habitable structures by not less than 60 inches (1524 mm) or by a minimum 2-hour fire-rated assembly.
3. *Townhouses* providing fire separation as required by the applicable code at the time of construction may be considered one structure and are permitted to comply with the provisions of Section R324.6.8.1, Exception 1.1.

R324.6.8.2 Intermediate pathway locations. Roof planes that include a *photovoltaic array* greater than 150 feet (45 720 mm) in length or width shall have additional intermediate *pathways*.

For every 150 feet (45 720 mm) of *photovoltaic array*, including offset *photovoltaic modules* or angled installations, an intermediate *pathway* not less than 36 inches (914 mm) in width separating the *photovoltaic array* shall be provided. The square footage of a *photovoltaic array* shall not exceed 22,500 square feet (2092 m²) without the installation of an intermediate *pathway*.

R324.6.8.2.1 Cutouts. Where a system is required to have intermediate *pathways*, all *pathways* shall have one or more *cutouts* located adjacent to the *pathway*. No point on the *pathway* shall be more than 25 feet (7620 mm) from a *cutout*.

R324.6.8.3 Prohibited pathway locations. *Pathways* shall not be located within 12 inches (305 mm) of the low point of a valley.

R324.6.8.4 Electrical component location. Electrical components shall be located in accordance with Sections R324.6.8.4.1 and R324.6.8.4.2.

R324.6.8.4.1 Disconnects, J-boxes, combiner boxes and gutters. Disconnects, J-boxes, combiner boxes and gutters shall not be located in any required *pathway* or *cutout*.

R324.6.8.4.2 Raceways. Raceways on flat roofs that cross a required *pathway* shall be bridged to avoid tripping hazards. Raceways shall not be permitted in required *pathways* on roof slopes greater than 2 units vertical in 12 units horizontal (2:12) (17-percent slope).

R324.6.9 Alternate installations. In accordance with Section R104.11, an alternative material, design, location, method of construction, or means of safe fire fighter access and egress may be *approved*.

Section R324.7

New and existing amendments:

The solar-ready provisions from Chapter 11 have been moved and expanded to include the provisions from the 2021 Oregon Residential Reach Code.

R324.7 Solar ready.

R324.7.1 Definitions. The following terms are defined in Chapter 2:

ROOF AREA.

TOTAL SOLAR RESOURCE FRACTION (TSRF)

R324.7.2 Solar ready construction. New detached one- and two-family dwellings and *townhouses* classified as Group R3 shall comply with Sections R324.7.3 and R324.7.4.

Exceptions:

1. New detached one- and two-family dwellings and *townhouses* with a permanently installed on-site renewable energy system, or an active permit application for an on-site permanently installed renewable energy system, as determined by the *building official*.
2. A building where there is less than 600 square feet (55.74 m²) of roof area oriented between 90 degrees and 270 degrees of true north.
3. A building with a *Total Solar Resource Fraction (TSRF)* of less than 80 percent, as documented and submitted and *approved* by the *building official*.
4. Where a *solar photovoltaic system* is infeasible because of structural configuration, extensive rooftop equipment, skylights, *vegetative roof areas*, other obstructions, or other unique design limitations, and where such documentation is *approved*.

R324.7.3 Solar interconnection pathway and termination.

A square metal junction box not less than 4 inches by 4 inches (102 mm by 102 mm) with a metal box cover shall be provided within 24 inches (610 mm) horizontally or vertically of the main electrical panel. A minimum ³/₄-inch (19 mm) nonflexible metal raceway with a pull string shall extend from the junction box to a capped roof termination or to an accessible location in the attic with a vertical clearance of not less than 36 inches (914 mm).

Where the raceway terminates in the attic, the termination shall be in a metal junction box not less than 4 inches by 4 inches (102 mm by 102 mm) with a box cover located not less than 6 inches (152 mm) above the insulation. The junction box shall be marked as "RESERVED FOR SOLAR."

Exception: In lieu of ³/₄-inch (19 mm) nonflexible metal raceway, a minimum of two No. 10 copper 3-wire with ground Metal Clad (MC) cable shall be installed between the junction boxes with 6 inches (152 mm) of free conductor in each junction box.

(Errata issued April 2024)

R324.7.4 Electrical service reserved space. The main electrical service panel, or other *approved* electrical panel that would serve the solar photovoltaic system, shall have a reserved space to allow installation of a dual-pole circuit breaker for future solar electric ~~and a dual-pole circuit breaker for future~~ installation. ~~These spaces~~ and shall be labeled "RESERVED FOR FUTURE SOLAR."

SECTION R325 MEZZANINES

R325.3 Area limitation. The aggregate area of a *mezzanine* or *mezzanines* shall be not greater than one-third of the floor area of the room or space in which they are located. The enclosed portion of a room shall not be included in a determination of the floor area of the room in which the *mezzanine* is located.

Exception: The aggregate area of a *mezzanine* located within a *dwelling unit* equipped with an automatic sprinkler system in accordance with [NFPA 13D or other approved sprinkler system](#) shall not be greater than one-half of the floor area of the room, provided that the *mezzanine* meets all of the following requirements:

1. Except for enclosed closets and bathrooms, the *mezzanine* is open to the room in which such *mezzanine* is located.
 2. The opening to the room is unobstructed except for walls not more than 42 inches (1067 mm) in height, columns and posts.
 3. The exceptions to Section R325.5 are not applied.
-

R325.5 Openness. *Mezzanines* shall be open and unobstructed to the room in which they are located except for walls not more than 36 inches (914 mm) in height, columns and posts.

Exceptions:

1. *Mezzanines* or portions thereof are not required to be open to the room in which they are located, provided that the aggregate floor area of the enclosed space is not greater than 10 percent of the *mezzanine* area.
 2. In buildings that are not more than two stories above *grade plane* and equipped throughout with an automatic sprinkler system in accordance with [NFPA 13D or other approved sprinkler system](#), a *mezzanine* shall not be required to be open to the room in which the *mezzanine* is located
-

SECTION R326 HABITABLE ATTICS

R326.3 Story above grade plane. A *habitable attic* shall be considered a story above *grade plane*.

Exceptions: A *habitable attic* shall not be considered to be a story above *grade plane* provided that the *habitable attic* meets all the following:

1. The aggregate area of the *habitable attic* is either of the following:
 - 1.1. Not greater than one-third of the floor area of the story below.
 - 1.2. Not greater than one-half of the floor area of the story below where the *habitable attic* is located within a *dwelling unit* equipped with [an automatic fire sprinkler system](#) in accordance with [NFPA 13D](#).
2. The occupiable space is enclosed by the roof assembly above, knee walls, if applicable, on the sides and the floor-ceiling assembly below.
3. The floor of the *habitable attic* does not extend beyond the *exterior walls* of the story below.
4. Where a *habitable attic* is located above a third story, the *dwelling unit* or *townhouse unit* shall be equipped [throughout with an automatic fire sprinkler system in accordance with NFPA 13D](#) ~~a fire sprinkler system in accordance with Section [P2904](#).~~

R326.4 Means of egress. The means of egress for *habitable attics* shall comply with the applicable provisions of Section R311.

SECTION R327 WILDFIRE HAZARD MITIGATION

New and existing amendments

Currently, the standards are available for all municipalities in the state to adopt and only apply to those areas within the county or city that are detailed in the adopting ordinance and identified on the locally required map.

Local building officials retain the flexibility to modify the requirements for any particular lot, property, or dwelling remodel or reconstruction activity based on the site details.

Note: The Oregon Legislature has established a comprehensive statewide policy regarding future application of these wildfire mitigation construction standards in Senate Bill 762 (2021) & 80 (2023).

Follow the implementation process: Oregon.gov/bcd/codes-stand/Pages/wildfire-hazard-mitigation.aspx

R327.1 General. The provisions of this section shall apply to dwellings and their accessory structures required by a local municipality via local ordinance to be protected against wildfire.

Nothing in the code prevents a local municipality from modifying the requirements of this section for any lot, property or dwelling, or the remodel, replacement or reconstruction of a dwelling within the jurisdiction, as provided in Section R104.10.

R327.1.1 Local adoption. The provisions of this section may be adopted in whole by a municipality via local ordinance without following ORS 455.040 or OAR 918-020-0370. Where a municipality chooses to adopt these provisions locally, the following shall be included in the adopting ordinance:

1. Identification of areas subject to the additional construction standards of Section R327.
2. A transition plan or other measures to address subdivisions already under development at the time of local adoption.
3. A local appeals process for customers to follow.

Where a municipality has previously adopted the provisions of Section R327 locally, the requirements of Section R327.1.1 do not apply and the existing local ordinance may continue without change, to include those based on prior iterations of this section.

R327.1.2 Notification. Where a municipality adopts Section R327 locally, or where a municipality has previously adopted Section R327 locally, the municipality shall notify the State of Oregon, Building Codes Division, and provide a copy of the locally adopted map identifying areas of the jurisdiction where the additional construction standards of Section R327 are required.

Senate Bill 762 (2021) & 80 (2023)

The local adoption provisions of §R327.1.1 and the application set forth by §R327.1.3 may be impacted by ongoing efforts to implement Senate Bills 762 (2021) and 80 (2023). These provisions will be updated accordingly to align with any actions taken by the legislature.

R327.1.3 Application. Where required by a municipality via local ordinance, newly constructed dwellings, their accessory structures, and new additions to existing dwellings and their accessory structures located in areas designated by the municipality shall be protected against wildfire in accordance with this section. Where existing exterior elements that are within the scope of this section are replaced in their entirety, the replacement shall be made in accordance with the provisions of this section.

Exceptions:

1. Nonhabitable detached accessory structures with a floor area of not greater than 400 square feet (37.2 m²) located not less than 50 feet (15 240 mm) from all other structures on the lot.
2. Partial repairs made in accordance with Section R105.2.2.

R327.2 Definitions. The following words and terms shall, for purposes of Section R327, have the meanings shown herein. See Chapter 2 for general definitions.

HEAVY TIMBER. For the use in this section, heavy timber shall be sawn lumber or glued-laminated wood with the smallest minimum nominal dimension of 4 inches (102 mm). Heavy timber walls or floors shall be sawn or glued-laminated planks splined, tongue-and-groove or set close together and well spiked.

IGNITION-RESISTANT MATERIAL. A type of building material that resists ignition or sustained flaming combustion sufficiently so as to reduce losses from wildland urban interface conflagrations under worst-case weather and fuel conditions with wildfire exposure of burning embers and small flames. Such materials include any product designed for exterior exposure that, when tested in accordance with ASTM E84 or UL 723 for surface burning characteristics of building materials, extended to a 30 minute duration, exhibits a flame spread index of not more than 25, shows no evidence of significant progressive combustion, and whose flame front does not progress more than 10¹/₂ feet (3200 mm) beyond the centerline of the burner at any time during the test.

NONCOMBUSTIBLE MATERIAL. Any material that in the form in which it is used and under the conditions anticipated will not ignite, burn, support combustion or release flammable vapors when subjected to fire or heat in accordance with ASTM E136.

WILDFIRE. Any uncontrolled fire spreading through vegetative fuels that threatens to destroy life, property or resources.

WILDFIRE EXPOSURE. One or a combination of circumstances exposing a structure to ignition, including radiant heat, convective heat, direct flame contact and burning embers being projected by a vegetation fire to a structure and its immediate environment.

R327.3 Roofing. Roofing shall be asphalt shingles in accordance with Section R905.2, slate shingles in accordance with Section R905.6, metal roofing in accordance with Section R905.4, tile, clay or concrete shingles in accordance with Section R905.3 or other *approved* roofing that is deemed to be equivalent to a minimum Class B-rated roof assembly. Wood shingle and shake roofs are not permitted on structures in areas designated by the *municipality*.

Where the roof profile allows a space between the roof covering and roof decking, the spaces shall be constructed to prevent the intrusion of flames and embers, be fireblocked with *approved* materials, or have one layer of minimum 72-pound (32.6 kg) mineral-surfaced nonperforated cap sheet complying with ASTM D3909 installed over the combustible decking.

Where valley flashing is installed, the flashing shall be not less than 0.019-inch (0.48 mm) No. 26 gage galvanized sheet corrosion-resistant metal installed over not less than one layer of minimum 72-pound (32.6 kg) mineral-surfaced nonperforated cap sheet complying with ASTM D3909 not less than 36-inch-wide (914 mm) running the full length of the valley.

R327.3.1 Gutters. Where required, roof gutters shall be constructed of *noncombustible materials* and be provided with a means to prevent accumulation of leaves and debris in the gutter.

R327.3.2 Ventilation. Where provided, the minimum net area of ventilation openings for enclosed attics, enclosed soffit spaces, enclosed rafter spaces and underfloor spaces shall be in accordance with Sections R408 and R806.

All ventilation openings shall be covered with noncombustible corrosion-resistant metal wire mesh, vents designed to resist the intrusion of burning embers and flame, or other *approved* materials or devices.

Ventilation mesh and screening shall be a minimum of $1/16$ -inch (1.6 mm) and a maximum of $1/8$ -inch (3.2 mm) in any dimension.

R327.3.2.1 Eaves, soffits and cornices. Ventilation openings shall not be installed on the underside of eaves, soffits or cornices.

Exceptions:

1. The *building official* may *approve* eave, soffit or cornice vents that are manufactured to resist the intrusion of flame and burning embers.
2. Ventilation openings complying with the requirements of Section R327.3.2 may be installed on the underside of eaves, soffits or cornices where the opening is located 12 feet (3658 mm) or greater above *grade* or the surface below.

R327.3.3 Exterior walls. The *exterior wall covering* or wall assembly shall comply with one of the following requirements:

1. *Noncombustible material.*
2. *Ignition-resistant material.*
3. *Heavy timber assembly.*
4. *Log wall construction assembly.*
5. Wall assemblies that have been tested in accordance with the test procedures for a 10-minute direct flame contact exposure test set forth in ASTM E2707, complying with the conditions of acceptance listed in Section R327.3.3.2.

Exception: Any of the following shall be deemed to meet the assembly performance criteria and intent of this section:

1. One layer of $5/8$ -inch (15.9 mm) Type X exterior gypsum sheathing applied behind the *exterior wall covering* or cladding on the exterior side of the framing.
2. The exterior portion of a 1-hour fire-resistance-rated *exterior wall* assembly designed for exterior fire exposure, including assemblies using exterior gypsum panel and sheathing products listed in the Gypsum Association *Fire Resistance and Sound Control Design Manual*.

R327.3.3.1 Extent of exterior wall covering. *Exterior wall coverings* shall extend from the top of the foundation to the roof and terminate at 2-inch (50.8 mm) nominal solid wood blocking between rafters at all roof overhangs, or in the case of enclosed eaves or soffits, shall terminate at the underside of the enclosure.

R327.3.3.2 Conditions of acceptance. ASTM E2707 tests shall be conducted in triplicate and the following conditions of acceptance shall be met. If any one of the three replicates do not meet the conditions of acceptance, three additional tests shall be conducted. All additional tests shall meet the following conditions of acceptance:

1. Absence of flame penetration through the wall assembly at any time during the test.
2. Absence of evidence of glowing combustion on the interior surface of the assembly at the end of the 70-minute test.

R327.3.4 Overhanging projections. All exterior projections (exterior balconies, carports, decks, patio covers, porch ceilings, unenclosed roofs and floors, overhanging buildings and similar architectural appendages and projections) shall be protected as specified in this section.

R327.3.4.1 Enclosed roof eaves, soffits and cornices. The exposed underside of rafter or truss eaves and enclosed soffits, where any portion of the framing is less than 12 feet (3658 mm) above *grade* or similar surface below, shall be protected by one of the following:

1. Noncombustible material.
2. Ignition-resistant material.
3. One layer of 5/8-inch (15.9 mm) Type X exterior gypsum sheathing applied behind an exterior covering on the underside of the rafter tails, truss tails or soffit.
4. The exterior portion of a 1-hour fire-resistance-rated exterior wall assembly applied to the underside of the rafter tails or soffit, including assemblies using exterior gypsum panel and sheathing products listed in the Gypsum Association *Fire Resistance and Sound Control Design Manual*.
5. Soffit assemblies with an underside surface that meets the performance criteria in Section R327.3.4.5 when tested in accordance ASTM E2957.

Exceptions: The following materials do not require protection required by this section:

1. Eaves and soffits where all portions of the framing members are 12 feet (3658 mm) or greater above *grade*, and 2-inch (610 mm) nominal eave fireblocking is provided between roof framing members from the wall top plate to the underside of the roof sheathing.
2. Gable end overhangs and roof assembly projections beyond an exterior wall other than at the lower end of the rafter tails.
3. Fascia and other architectural trim boards.

R327.3.4.2 Exterior patio and porch ceilings. The exposed underside of exterior patio and porch ceilings greater than 200 square feet (18.58 m²) in area and less than 12 feet (3658 mm) above *grade* shall be protected by one of the following:

1. Noncombustible material.
2. Ignition-resistant material.
3. One layer of 5/8-inch (15.9 mm) Type X exterior gypsum sheathing applied behind the exterior covering on the underside of the ceiling.
4. The exterior portion of a 1-hour fire-resistance-rated exterior wall assembly, applied to the underside of

the ceiling assembly including assemblies using exterior gypsum panel and sheathing products listed in the Gypsum Association *Fire Resistance and Sound Control Design Manual*.

5. Porch ceiling assemblies with a horizontal underside that meet the performance criteria in Section R327.3.4.5 when tested in accordance with the test procedures set forth in ASTM E2957.

Exception: Architectural trim boards.

R327.3.4.3 Floor projections. The exposed underside of cantilevered floor projections less than 12 feet (3658 mm) above *grade* or the surface below shall be protected by one of the following:

1. Noncombustible material.
2. Ignition-resistant material.
3. One layer of 5/8-inch (15.9 mm) Type X exterior gypsum sheathing applied behind an exterior covering on the underside of the floor projection.
4. The exterior portion of a 1-hour fire-resistance-rated exterior wall assembly applied to the underside of the floor projection, including assemblies using exterior gypsum panel and sheathing products listed in the Gypsum Association *Fire Resistance and Sound Control Design Manual*.
5. An assembly that meets the performance criteria in Section R327.3.4.5 when tested in accordance with ASTM E2957.

Exception: Architectural trim boards.

R327.3.4.4 Underfloor protection. The underfloor area of elevated structures shall be enclosed to *grade* in accordance with the requirements of this section, or the underside of the exposed underfloor shall be protected by one of the following:

1. Noncombustible material.
2. Ignition-resistant material.
3. One layer of 5/8-inch (15.9 mm) Type X exterior gypsum sheathing applied behind an exterior covering on the underside of the floor assembly.
4. The exterior portion of a 1-hour fire-resistance-rated exterior wall assembly applied to the underside of the floor, including assemblies using exterior gypsum panel and sheathing products listed in the Gypsum Association *Fire Resistance and Sound Control Design Manual*.
5. An assembly that meets the performance criteria in Section R327.3.4.5 when tested in accordance with ASTM E2957.

Exception: Heavy timber structural columns and beams do not require protection.

R327.3.4.5 Conditions of acceptance. ASTM E2957 tests shall be conducted in triplicate, and the following conditions of acceptance shall be met. If any one of the three replicates do not meet the conditions of acceptance, three additional tests shall be conducted. All additional tests shall meet the following conditions of acceptance:

1. Absence of flame penetration of the eaves or horizontal projection assembly at any time during the test.
2. Absence of structural failure of the eaves or horizontal projection subassembly at any time during the test.
3. Absence of sustained combustion of any kind at the conclusion of the 40-minute test.

R327.3.5 Walking surfaces. Deck, porch and balcony walking surfaces located greater than 30 inches (762 mm) and less than 12 feet (3658 mm) above *grade* or the surface below shall be constructed with one of the following materials:

1. Materials that comply with the performance requirements of Section R327.3.5.1 when tested in accordance with both ASTM E2632 and ASTM E2726.
2. Ignition-resistant materials that comply with the performance requirements of Section R327.2 when tested in accordance with ASTM E84 or UL 723.
3. Exterior fire-retardant-treated wood.
4. Noncombustible material.
5. Any material that complies with the performance requirements of Section R327.3.5.2 where tested in accordance with ASTM E2632, where the exterior wall covering of the structure is noncombustible or ignition-resistant material.
6. Any material that complies with the performance requirements of ASTM E2632, where the exterior wall covering of the structure is noncombustible or ignition-resistant material.

Exception: Wall covering material may be of any material that otherwise complies with this chapter where the decking surface material complies with the performance requirements ASTM E84 with a Class B flame spread rating.

Exception: Walking surfaces of decks, porches and balconies not greater than 200 square feet (18.58 m²) in area, where the surface is constructed of nominal 2-inch (51 mm) lumber.

R327.3.5.1 Requirements for Section R327.3.5, Item 1. The material shall be tested in accordance with ASTM E2632 and ASTM E2726, and shall comply with the conditions of acceptance in Sections R327.3.5.1.1 and R327.3.5.1.2. The material shall also comply with the performance requirements of Section R327.2 for ignition-resistant material when tested in accordance with ASTM E84 or UL 723.

R327.3.5.1.1 Conditions of acceptance. ASTM E2632 tests shall be conducted in triplicate and the following conditions of acceptance shall be met. If any one of the three replicates do not meet the conditions of acceptance, three additional tests shall be conducted. All additional tests shall meet the following conditions of acceptance:

1. Peak heat release rate of less than or equal to 25 kW/ft² (269 kW/m²).
2. Absence of sustained flaming or glowing combustion of any kind at the conclusion of the 40-minute observation period.
3. Absence of falling particles that are still burning when reaching the burner or floor.

R327.3.5.1.2 Conditions of acceptance. ASTM E2762 tests shall be conducted in triplicate and the following conditions of acceptance shall be met. If any one of the three replicates do not meet the conditions of acceptance, three additional tests shall be conducted. All of the additional tests shall meet the following conditions of acceptance:

1. Absence of sustained flaming or glowing combustion of any kind at the conclusion of the 40-minute observation period.
2. Absence of falling particles that are still burning when reaching the burner or floor.

R327.3.5.2 Requirements for Section R327.3.5, Item 6. The material shall be tested in accordance with ASTM E2632 and shall comply with the following conditions of acceptance. The test shall be conducted in triplicate and the peak heat release rate shall be less than or equal to 25 kW/ft² (269 kW/m²). If any one of the three replicates do not meet the conditions of acceptance, three additional tests shall be conducted. All of the additional tests shall meet the conditions of acceptance.

R327.3.6 Glazing. Exterior windows, windows within exterior doors, and skylights shall be tempered glass, multilayered glazed panels, glass block or have a fire-resistance rating of not less than 20 minutes.

SECTION R328 DETACHED GROUP R ACCESSORY STRUCTURES (GROUP U)

Rescinded amendments

The definition for “accessory structure” now aligns with the national model code. The definition no longer specifies 3,000 sq. ft. in area and two-story height limitations. This model code change occurred in the 2015 IRC.

2021 ORSC Section R328, Detached Group R Accessory Structures (Group U), is no longer necessary in the code and has been rescinded.

~~**R328.1 Purpose.** The purpose of this section is to provide for tabulated allowable area increases for detached Group R accessory structures (Group U) based on the availability of open spaces between adjacent buildings and/or property lines.~~

~~**R328.2 Scope.** The provisions of this section are limited to detached Group R accessory structures, which are not more than one story above grade plane in height. Mezzanines may be included within detached accessory structures but shall be limited to an aggregate floor area of not more than one-third of the area of the room or space in which the level is located.~~

~~**R328.3 Definitions.** The following words and terms shall, for the purposes of this section, have the meanings shown herein:~~

~~**SEPARATION DISTANCE.** The distance measured from the detached accessory structure exterior face to one of the following:~~

- ~~1. The closest interior lot line.~~
- ~~2. The centerline of a street, an alley or a public way.~~
- ~~3. Residences or other accessory structures on the same property.~~

~~The distance shall be measured at right angles from the face of the wall.~~

~~**R328.4 Allowable area.** The 3,000 square foot (279 m²) area limitation imposed by definition for residential accessory structures shall be permitted to be increased where separation distances are provided on all sides of a detached accessory structure in accordance with Table R328.4.~~

~~**Exceptions:** Where a separation distance of 10 feet (3048 mm) or more is provided, 1-hour fire resistance rated construction may be substituted for the separation distance noted in Table R328.4 for one side of a detached accessory structure subject to the following conditions:~~

~~1. A minimum separation distance of 10 feet (3048 mm) must be provided adjacent to the 1-hour fire resistance-rated exterior wall.~~

~~2. Openings in the 1-hour fire resistance-rated exterior wall are limited to 15 percent of the area of the wall.~~

~~**R328.4.1 Residential accessory structures on same lot.** For the purposes of this section, two or more detached residential accessory structures on the same lot shall be regulated as separate buildings or shall be considered as portions of one building if the aggregate area of the buildings is within the limitations of Table R328.4.~~

~~Where aggregate building areas are being considered as portions of one building, the separation distances specified in Table R328.4 shall be applicable to all exterior building faces which establish the aggregate building perimeter.~~

~~**R328.4.2 Projections.** Projections of exterior walls shall comply with Table R302.1 of this code.~~

**TABLE R328.4
ALLOWABLE AREA INCREASE DETACHED
GROUP R ACCESSORY BUILDINGS**

Separation Distance (feet)	Allowable Area (square feet)
5	3,500
10	4,000
15	4,500
20	5,000
25	5,500
30	6,000
35	7,000
40	8,000
45	9,000
50	10,000
55	11,000
60 or greater	12,000

For SI: 1 foot = 308.4 mm, 1 square foot = 0.0929 m².

SECTION ~~R328~~ R327 SWIMMING POOLS, SPAS AND HOT TUBS

~~**R328.1 General.** The design and construction of barriers for residential swimming pools and spas that are accessory to four or fewer dwelling units shall comply with Section 305 of the International Swimming Pool and Spa Code.~~

Note: When a municipality adopts a local ordinance in accordance with Section R101.2.2(7) requiring a permit for the design and construction of in-ground swimming pools, the design and construction shall be in accordance with the International Swimming Pool and Spa Code.

SECTION ~~R329~~ ~~R328~~ ENERGY STORAGE SYSTEMS

R329.1 General. *Energy storage systems (ESS)* shall comply with the provisions of this section.

Exceptions:

1. *ESS listed and labeled* in accordance with UL 9540 and marked “For use in residential dwelling units” where installed in accordance with the manufacturer’s instructions and [the Electrical Code](#).
2. *ESS less than 1 kWh (3.6 megajoules)*.

R329.2 Equipment listings. *Energy storage systems (ESS)* shall be *listed* and *labeled* in accordance with UL 9540.

Exception: Where *approved*, repurposed unlisted battery systems from electric vehicles are allowed to be installed outdoors or in detached sheds located not less than 5 feet (1524 mm) from *exterior walls*, ~~*lot lines*~~ ~~*property lines*~~ and public ways.

R329.3 Installation. *ESS* shall be installed in accordance with the manufacturer’s instructions and their *listing*.

R329.3.1 Spacing. Individual units shall be separated from each other by not less than 3 feet (914 mm) except where smaller separation distances are documented to be adequate based on large-scale fire testing complying [the Building Code](#).

R329.4 Locations. *ESS* shall be installed only in the following locations:

1. Detached garages and detached *accessory structures*.
2. Attached garages separated from the *dwelling unit* living space in accordance with Section R302.6.
3. Outdoors or on the exterior side of *exterior walls* located not less than 3 feet (914 mm) from doors and windows directly entering the *dwelling unit*.
4. Enclosed utility closets, basements, storage or utility spaces within *dwelling units* with finished or noncombustible walls and ceilings. Walls and ceilings of unfinished wood-framed construction shall be provided with not less than 5/8-inch (15.9 mm) Type X gypsum wallboard.

ESS shall not be installed in sleeping rooms, or closets or spaces opening directly into sleeping rooms.

R329.5 Energy ratings. Individual *ESS* units shall have a maximum rating of 20 kWh. The aggregate rating of the *ESS* shall not exceed:

1. 40 kWh within utility closets, basements and storage or utility spaces.
2. 80 kWh in attached or detached garages and detached *accessory structures*.
3. 80 kWh on *exterior walls*.
4. 80 kWh outdoors on the ground.

ESS installations exceeding the permitted individual or aggregate ratings shall be installed in accordance with [the Building Code](#).

R329.6 Electrical installation. *ESS* shall be installed in accordance with [the Electrical Code](#). Inverters shall be *listed* and *labeled* in accordance with UL 1741 or provided as part of the UL 9540 listing. Systems connected to the utility grid shall use inverters *listed* for utility interaction.

R329.7 Fire detection. Rooms and areas within *dwelling units*, basements and attached garages in which *ESS* are installed shall be protected by smoke alarms in accordance with Section R314. A heat detector, *listed* and interconnected to the smoke alarms, shall be installed in locations within *dwelling units* and attached garages where smoke alarms cannot be installed based on their *listing*.

R329.8 Protection from impact. *ESS* installed in a location subject to vehicle damage shall be protected by *approved* barriers.

R329.9 Ventilation. Indoor installations of *ESS* that produce hydrogen or other flammable gases during charging shall be provided with mechanical *ventilation* in accordance with Section M1307.4.

R329.10 Electric vehicle use. The temporary use of an *owner* or occupant’s electric-powered vehicle to power a *dwelling unit* while parked in an attached or detached garage or outdoors shall comply with the vehicle manufacturer’s instructions and [the Electrical Code](#).

R329.11 Documentation and labeling. The following information shall be provided:

1. A copy of the manufacturer’s installation, operation, maintenance and decommissioning instructions shall be provided to the owner or placed in a conspicuous location near the *ESS* equipment.
2. A label on the installed system containing the contact information for the qualified maintenance and service providers.

SECTION ~~R330~~ ~~R329~~ STATIONARY ENGINE GENERATORS

IRC R329.1 General. *...Not adopted.*

R330.1 Installation. The installation of stationary engine generators shall be in an *approved* location and in accordance with the listing, the *manufacturer's installation instructions* and the *Electrical Code*.

SECTION ~~R331~~ ~~R330~~ STATIONARY FUEL CELL POWER SYSTEMS

R331.1 General. *Stationary fuel cell power systems* in new and existing buildings and structures shall comply with the *Building Code*.

CHAPTER 4 FOUNDATIONS

SECTION R401 GENERAL

R401.1 Application. The provisions of this chapter shall control the design and construction of the foundation and foundation spaces for buildings. In addition to the provisions of this chapter, the design and construction of foundations in flood hazard areas as established by [the flood plain administrator Table R301.2](#) shall meet the provisions of Section R322. Wood foundations shall be designed and installed in accordance with AWC PWF.

Exception: The provisions of this chapter shall be permitted to be used for wood foundations only in the following situations:

1. In buildings that have not more than two floors and a roof.
2. Where interior *basement* and foundation walls are constructed at intervals not exceeding 50 feet (15 240 mm).

Wood foundations in *Seismic Design Category* D₀, D₁ or D₂ shall be designed in accordance with [Section R301.1.3-accepted engineering practice](#).

R401.2 Requirements. Foundation construction shall be capable of accommodating all loads in accordance with Section R301 and of transmitting the resulting loads to the supporting soil. [Where a construction joint is created between a concrete footing and foundation wall, a means of restraint shall be provided to prevent lateral displacement. Such restraint shall be provided by forming a minimum 1 1/2-inch \(38 mm\) wide by 1 1/2-inch \(38 mm\) deep continuous keyway within the middle one-third of the wall, installing vertical bars in accordance with Section R403.1.3.1 or other approved method.](#) Fill soils that support footings and foundations shall be designed, installed and tested in accordance with [Section R301.1.3-accepted engineering practice](#).

Section R401.2 – New amendment

Brings back a requirement from previous ORSC editions to provide lateral restraint between the bottom of the foundation wall and footing construction joints in low seismic regions. This change aligns with ACI 332, *Code Requirements for Residential Concrete and Commentary*, and PCA 100, *Prescriptive Design of Exterior Concrete Walls for One- and Two-Family Dwellings*.

R401.3 Drainage. Surface drainage shall be diverted to a storm sewer conveyance or other *approved* point of collection that does not create a hazard. *Lots* shall be graded to drain surface water away from foundation walls. The *grade* shall fall not fewer than 6 inches (152 mm) within the first 10 feet (3048 mm).

Exception: Where *lot lines*, walls, slopes or other physical barriers prohibit 6 inches (152 mm) of fall within 10 feet (3048 mm), drains, ~~or~~ swales [or other means shall be provided and](#) shall be constructed to ensure drainage away from the structure. Impervious surfaces within 10 feet (3048 mm) of the building foundation shall be sloped not less than 2 percent away from the building.

R401.4 Soil tests. Where ~~quantifiable data created by accepted soil science methodologies~~ indicate *expansive soils, compressible soils*, shifting soils or other questionable soil characteristics are likely to be present, the *building official* shall determine whether to require a soil test to determine the soil's characteristics at a particular location. This test shall be done by an *approved agency* using an *approved method*.

SECTION R403 FOOTINGS

R403.1 General. All exterior walls shall be supported on continuous solid or fully grouted masonry or concrete footings, crushed stone footings, wood foundations, or other *approved* structural systems that shall be of sufficient design to accommodate all loads according to Section R301 and to transmit the resulting loads to the soil within the limitations as determined from the character of the soil. Footings shall be supported on undisturbed natural soils or [fill coils in accordance with Section R401.2-engineered fill](#). Concrete footings shall be designed and constructed in accordance with the provisions of Section R403 or in accordance with ACI 332.

TABLE R403.1
MINIMUM WIDTH OF CONCRETE, PRECAST OR MASONRY FOOTINGS (inches)^a

	LOAD-BEARING VALUE OF SOIL (psf)			
	1,000	1,500	2,000	≥ 3,000
Conventional light-frame construction				
1 story	18	12	12	12
2 story	23	15	12	12
3 story	35	23	17	12
4-inch brick veneer over light frame or 8-inch hollow concrete masonry				
1 story	18	12	12	12
2 story	32	21	16	12
3 story	48	32	24	16
8-inch solid concrete or masonry or fully grouted masonry				
1 story	24	16	12	12
2 story	44	29	21	14
3 story	63	42	32	21

For SI: 1 inch = 25.4 mm, 1 pound per square foot = 0.0479 kPa.

a. Where minimum footing width is 12 inches, use of a single wythe of solid or fully grouted 12-inch nominal concrete masonry units is permitted.

IRC Tables R403.1(1) through R403.1(3). ...*Not adopted.*

R403.1.1 Minimum size. ~~The minimum width, W, and thickness, T, for concrete~~ Concrete and masonry footings shall be in accordance with ~~Tables R403.1(1) through R403.1(3)~~ Table R403.1 and Figure R403.1(1) or R403.1.3, as applicable, **but not less than 12 inches (305 mm) in width and 6 inches (152 mm) in depth.** The footing width shall be based on the load-bearing value of the soil in accordance with Table R401.4.1. Spread footings shall be not less than 6 inches (152 mm) in thickness for foundation walls supporting one floor, 7 inches (178 mm) in thickness for foundation walls supporting two floors, and 8 inches (203 mm) in thickness for foundation walls supporting three floors. Footing projections, P, shall be not less than 2 inches (51 mm) and shall not exceed the thickness of the footing. Footing thickness and projection for fireplaces shall be in accordance with Section R1001.2. The size of footings supporting piers and columns shall be based on the tributary load and allowable soil pressure in accordance with Table R401.4.1. For isolated footings, see Section R403.1.7. Footings for wood foundations shall be in accordance with the details set forth in Section R403.2, and Figures R403.1(2) and R403.1(3). Footings for precast foundations shall be in accordance with the details set forth in Section R403.4, Table R403.4, and Figures R403.4(1) and R403.4(2).

R403.1.2 Continuous footing in Seismic Design Categories D₀, D₁ and D₂. Exterior walls and required interior braced wall panels of buildings located in *Seismic Design Categories D₀, D₁ and D₂* shall be supported by continuous (from beginning to end of braced wall line) *solid* or fully grouted masonry or concrete footings in accordance with Table R403.1.2. Other footing materials or systems shall be designed in accordance with Section R301.1.3 ~~accepted engineering practice.~~

Section R403.1.2 – New amendment

Brings in 2024 IRC approved change replacing the confusing continuous footing requirements in high seismic language with a new table for clarification.

~~Required interior braced wall panels in buildings located in Seismic Design Categories D₀, D₁ and D₂ with plan dimensions greater than 50 feet (15 240 mm) shall be supported by continuous solid or fully grouted masonry or concrete footings in accordance with Section R403.1.3.4, except for two-story buildings in Seismic Design Category D₂, in which all braced wall panels, interior and exterior, shall be supported on continuous foundations.~~

Exception: Two-story buildings shall be permitted to have interior *braced wall panels* supported on continuous foundations at intervals not exceeding 50 feet (15 240 mm) provided that:

1. The height of cripple walls does not exceed 4 feet (1219 mm).
2. First floor *braced wall panels* are supported on doubled floor joists, continuous blocking or floor beams.
3. The distance between bracing lines does not exceed twice the building width measured parallel to the *braced wall line*.

**TABLE R403.1.2
CONTINUOUS FOOTING REQUIREMENTS IN SEISMIC DESIGN CATEGORIES D₀, D₁ AND D₂**

BUILDING PLAN DIMENSIONS	1-STORY						2-STORY						3-STORY	
	50 feet or less			≥ 50 feet			50 feet or less			≥ 50 feet			Any	
SDC	D ₀	D ₁	D ₂	D ₀	D ₁	D ₂	D ₀	D ₁	D ₂	D ₀	D ₁	D ₂	D ₀	D ₁
Continuous footings supporting exterior walls	R	R	R	R	R	R	R	R	R	R	R	R	R	R
Continuous footings supporting required interior braced wall panels	NR	NR	NR	R ^a	R ^a	R ^a	NR	NR	R ^a	R ^a	R ^a	R ^a	R	R

R = Continuous solid or fully grouted masonry or concrete footings in accordance with Section R403.1.3.4 required.

NR = Continuous footings not required.

a. Buildings shall be permitted to have interior braced wall panels supported on continuous foundations at intervals not exceeding 50 feet provided that the following conditions are met:

1. The height of cripple walls does not exceed 4 feet.
2. First-floor braced wall panels are supported on doubled floor joists, continuous blocking or floor beams.
3. The distance between bracing lines does not exceed twice the building width measured parallel to the braced wall line.

R403.1.3 Footing and stem wall reinforcing in Seismic Design Categories D₀, D₁ and D₂. Concrete footings and stem walls located in *Seismic Design Categories* D₀, D₁ and D₂, as established in Table R301.2, shall have minimum reinforcement in accordance with this section, Section R404 and Figure R403.1.3. Reinforcement shall be installed with support and cover in accordance with Section R403.1.3.5.

R403.1.4 Minimum depth. Exterior footings shall be placed not less than 12 inches (305 mm) below finished grade on the undisturbed ground surface. Where applicable, the depth of footings shall also conform to Section R403.1.4.1. **Deck footings shall be in accordance with Section R507.3.**

R403.1.6 Foundation anchorage. Wood sill plates and wood walls supported directly on continuous foundations shall be anchored to the foundation in accordance with this section. [...]

Section R403.1.6 – Model code change

Wet-setting mudsill anchor bolts is now allowed in certain conditions.

Sill plates and sole plates shall be protected against decay ~~and termites~~ where required by Sections ~~R317 and R318~~. **Anchor bolts shall be permitted to be located while concrete is still plastic and before it has set. Where anchor bolts resist placement or the consolidation of concrete around anchor bolts is impeded, the concrete shall be vibrated to ensure full contact between the anchor bolts and concrete.**

[The exceptions remain unchanged]

R403.1.7 Isolated footings. Plain isolated square or round footings shall be permitted subject to the limitations in Sections R403.1.7.1 and R403.1.7.2.

R403.1.7.1 Isolated footings in the crawl space. Plain concrete isolated footings supporting a single floor system whose total loads do not exceed 50 pounds per square foot (2394 Pa) (40 pounds live load, 10 pounds dead load) shall be a minimum size of 18 inches in diameter by 8 inches in depth (457 mm by 203 mm) or 1.7 square feet in plan area (15 inches square) by 8 inches in depth (0.16 m² by 203 mm) where the following conditions are met:

1. Crawl spaces are enclosed by a continuous concrete or masonry foundation.
2. Floor beam spacing does not exceed 48 inches (1219 mm) on center and the maximum size of wood floor girders is 4 inches by 8 inches (102 mm by 203 mm) or 6 inches by 6 inches (152 mm by 152 mm). See Table R502.5.

Plain concrete isolated footings supporting other floor loads in an enclosed crawl space shall not exceed 6.25 square feet in plan area (30 inches square) by 15 inches in depth (0.58m² mm by 381 mm) or 34 inches in diameter by 17 inches in depth (864 mm by 432 mm). Where the axial load exceeds 9,000 pounds (4082 kg), the footing shall be designed in accordance with Section R301.1.3.

R403.1.7.2 Outside isolated footings. Plain concrete isolated footings located outside of an enclosed crawl space shall not exceed 6.25 feet square in plan area by 15 inches in depth (0.58m² by 381 mm) or 34 inches in diameter by 17 inches in depth (864 mm by 432 mm). Where the axial load exceeds 9,000 pounds (4082 kg), the footing shall be designed in accordance with Section R301.1.3. The footing shall meet the frost depth requirements of Table R301.2.

Figures R403.1(1), R403.1(2), R403.1(3) and R403.1.3

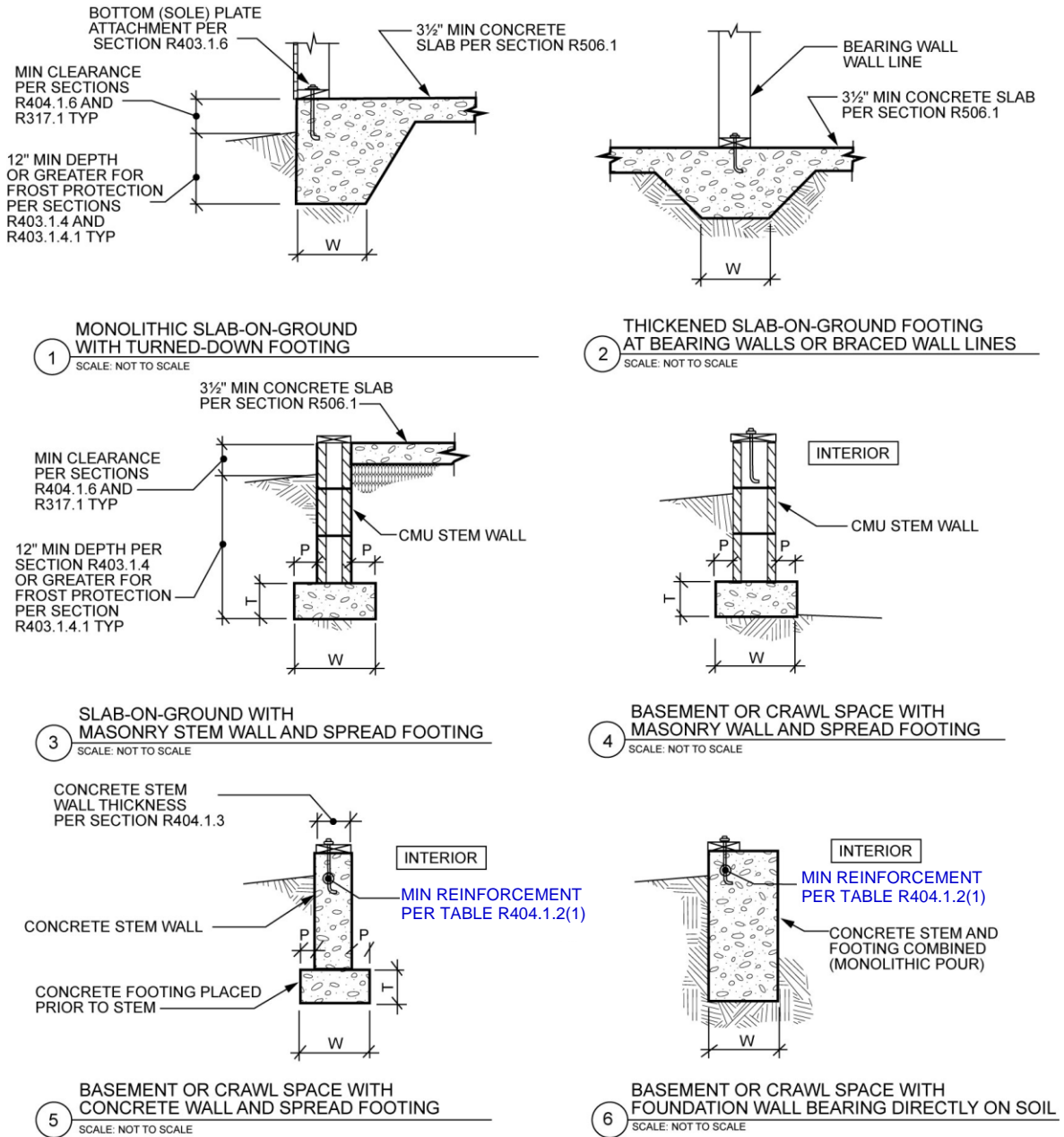

For SI: 1 inch = 25.4 mm.

W = Width of footing per Table R403.1, T = Thickness of footing and P = Projection per Section R403.1.1.

NOTES:

- a. See Section R404.3 for sill requirements.
- b. See Section R403.1.6 for sill attachment.
- c. See Section R506.2.3 for vapor retarder barrier requirements.
- d. See Section R403.1 for base.
- e. See Figure R403.1.3 for additional footing requirements for structures in Seismic Design Categories D₀, D₁ and D₂ and townhouses in Seismic Design Category C.
- f. See Section R408 for under-floor ventilation and access requirements.
- g. See Section R401.2 for foundation wall to footing restraint requirements.

FIGURE R403.1(1)
PLAIN CONCRETE FOOTINGS WITH MASONRY AND CONCRETE STEM WALLS IN SEISMIC DESIGN CATEGORIES A, B AND C^{a, b, c, d, e, f}

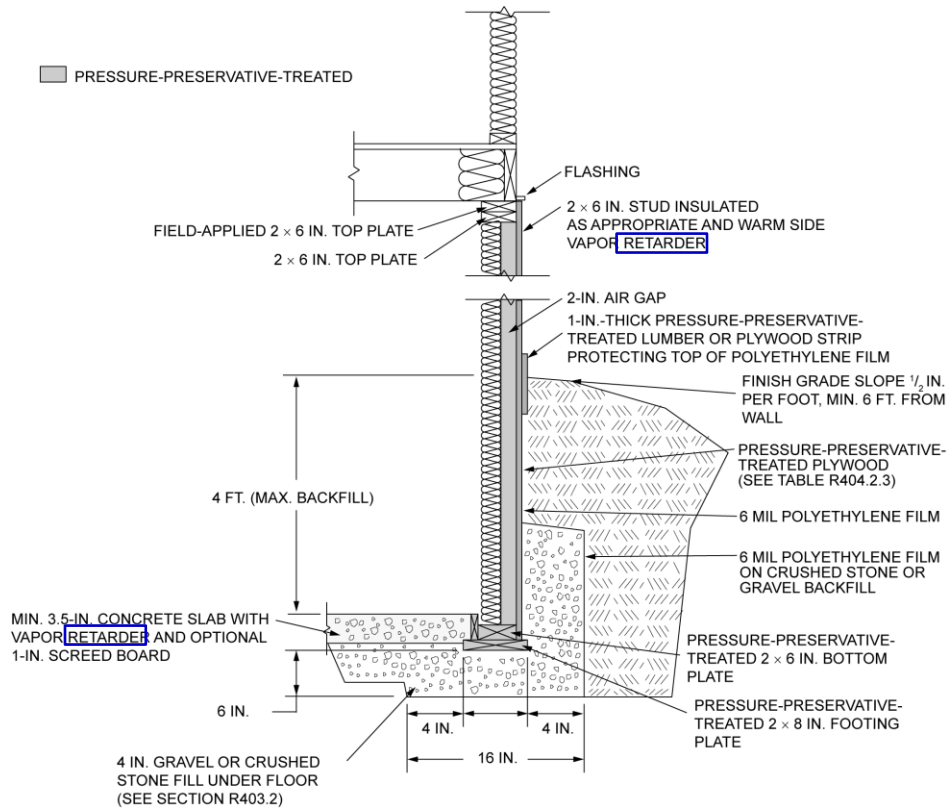

FIGURE R403.1(2)
PERMANENT WOOD FOUNDATION BASEMENT WALL SECTION

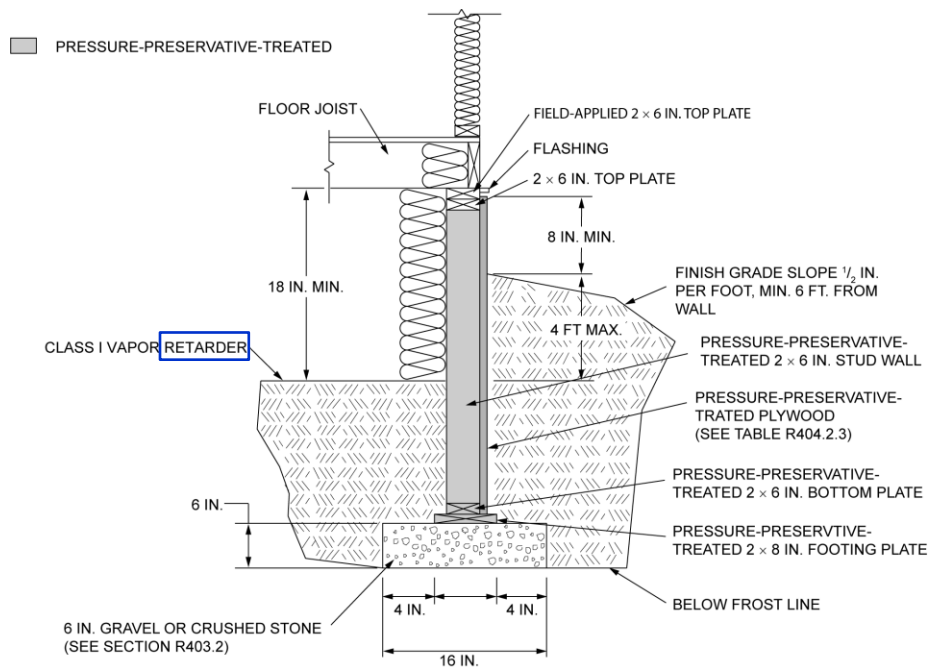
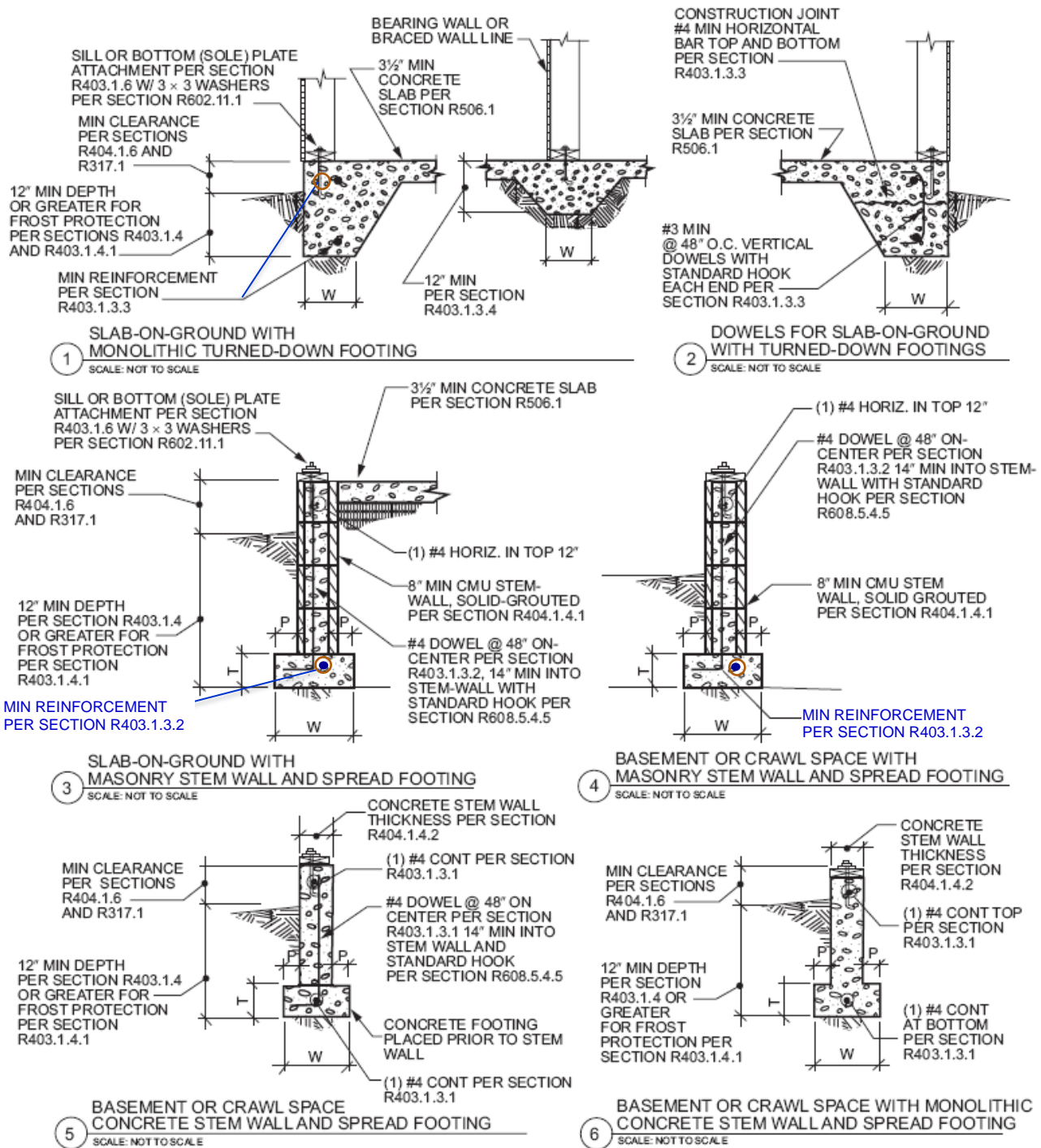

FIGURE R403.1(3)
PERMANENT WOOD FOUNDATION CRAWL SPACE SECTION



For SI: 1 inch = 25.4 mm.

W = Width of footing per Table R403.1, T = Thickness of footing and P = Projection per Section R403.1.1.

NOTES:

- a. See Section R404.3 for sill requirements.
- b. See Section R403.1.6 for sill attachment.
- c. See Section R506.2.3 for vapor retarder barrier requirements.
- d. See Section R403.1 for base.
- e. See Section R408 for under-floor ventilation and access requirements.
- f. See Section R403.1.3.5 for reinforcement requirements.

FIGURE R403.1.3
REINFORCED CONCRETE FOOTINGS AND MASONRY AND CONCRETE STEM WALLS IN SDC D₀, D₁ AND D₂ a, b, c, d, e, f

R403.1.8 Grounding electrodes. Where concrete reinforcing bars are installed in concrete footings, the following requirements shall be met to provide for a grounding electrode system:

1. Uncoated No. 4 reinforcing bar installed not less than 3 inches (76 mm) from the bottom of the footing and not less than 20 feet (6096 mm) in length encased with a minimum of 2 inches (51 mm) of concrete.
2. An uncoated No. 4 reinforcing bar stubbed up at least 12 inches (305 mm) above the floor plate line and tightly attached with a minimum of three ties to the reinforcing bar located in the footing. The spliced lap of the stubbed up bar to the footing bar shall be a minimum of 12 inches (305 mm).

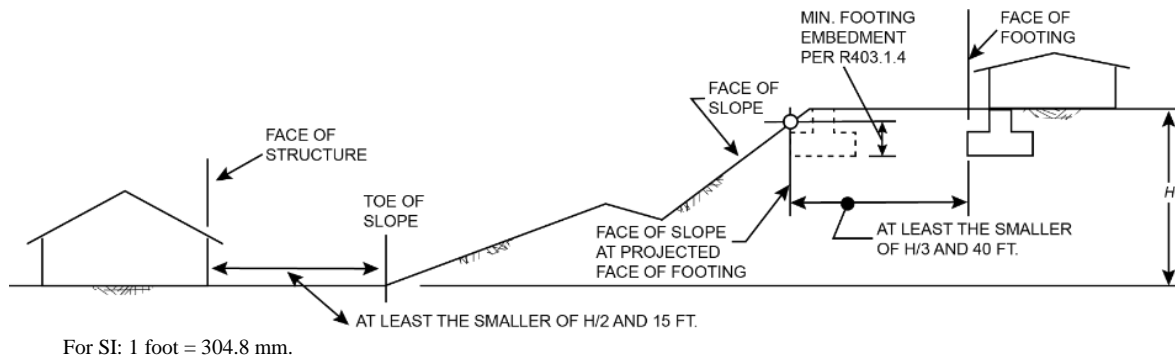

FIGURE R403.1.9.1 R403.1.7.4
FOUNDATION CLEARANCE FROM SLOPES

R403.1.9.4 R403.1.7.4 Alternate setbacks and clearances. Alternate setbacks and clearances are permitted, subject to the approval of the *building official*. The *building official* is permitted to require an investigation and *approved documentation demonstrating recommendation of a qualified engineer to demonstrate* that the intent of this section has been satisfied. Such an investigation shall include consideration of material, height of slope, slope gradient, load intensity and erosion characteristics of slope material.

IRC Figure R403.3(2) Air-Freezing Index an Estimate ...*Not adopted.*

IRC Table R403.3(2) Air-Freezing Index for US Locations by County. ...*Not adopted.*

IRC R403.3.4 Termite protection. ...*Not adopted.*

SECTION R404 FOUNDATION AND RETAINING WALLS

R404.1.1 Design required. Concrete or masonry foundation walls shall be designed in accordance with ~~accepted engineering practice~~ Section R301.1.3 where either of the following conditions exists:

1. Walls are subject to hydrostatic pressure from ground water.
2. Walls supporting more than 48 inches (1219 mm) of unbalanced backfill that do not have permanent lateral support at the top ~~and~~ ~~or~~ bottom.

R404.1.2 Design of masonry foundation walls. Masonry foundation walls shall be designed and constructed in accordance with the provisions of this section or in accordance with the provisions of TMS 402. ~~Where TMS 402 or the provisions of this section are used to design masonry foundation walls, project drawings, typical details and specifications are not required to bear the seal of the architect or engineer responsible for design, unless otherwise required by the state law of the jurisdiction having authority.~~

TABLE R404.1.2(1)
MINIMUM HORIZONTAL REINFORCEMENT FOR
CONCRETE FOUNDATION ~~BASEMENT~~ WALLS^{a, b}

MAXIMUM UNSUPPORTED WALL HEIGHT (feet)	LOCATION OF HORIZONTAL REINFORCEMENT
≤ 8	One No. 4 bar within 12 inches of the top of the wall story and one No. 4 bar near mid-height of the wall-story.
> 5 to ≤ 8	<u>One No. 4 bar within 12 inches of the top of the wall and one No. 4 bar near mid-height of the wall.</u>
> 8	One No. 4 bar within 12 inches of the top of the wall story and one No. 4 bar near third points in the wall-story.

For SI: 1 inch = 25.4 mm, 1 foot = 304.8 mm, 1 pound per square inch = 6.895 kPa.

- a. Horizontal reinforcement requirements are for reinforcing bars with a minimum yield strength of 40,000 psi and concrete with a minimum concrete compressive strength of 2,500 psi.
- b. See Section R404.1.3.2 for minimum reinforcement required for foundation walls supporting above-grade concrete walls.

R404.1.3 Concrete foundation walls. Concrete foundation walls that support light-frame walls shall be designed and constructed in accordance with the provisions of this section, ACI 318, ACI 332 or PCA 100. Concrete foundation walls that support above-grade concrete walls that are within the applicability limits of Section R608.2 shall be designed and constructed in accordance with the provisions of this section, ACI 318, ACI 332 or PCA 100. Concrete foundation walls that support above-grade concrete walls that are not within the applicability limits of Section R608.2 shall be designed and constructed in accordance with the provisions of ACI 318, ACI 332 or PCA 100. ~~Where ACI 318, ACI 332, PCA 100 or the provisions of this section are used to design concrete foundation walls, project drawings, typical details and specifications are not required to bear the seal of the architect or engineer responsible for design, unless otherwise required by the state law of the jurisdiction having authority.~~

R404.1.3.2 Reinforcement for foundation walls. Concrete foundation walls shall be laterally supported at the top and bottom. Horizontal reinforcement shall be provided in accordance with Table R404.1.2(1). Vertical reinforcement shall be provided in accordance with Table R404.1.2(2), R404.1.2(3), R404.1.2(4), R404.1.2(5), R404.1.2(6), R404.1.2(7) or R404.1.2(8).

Vertical reinforcement for flat *basement* walls retaining 4 feet (1219 mm) or more of unbalanced backfill is permitted to be determined in accordance with Table R404.1.2(9). For basement foundation walls supporting above-grade concrete walls, vertical reinforcement shall be the greater of that required by Tables R404.1.2(2) through R404.1.2(8) or by Section R608.6 for the above-grade wall. In buildings assigned to *Seismic Design Category* D₀, D₁ or D₂, concrete foundation walls shall also comply with Sections R403.1.3 and R404.1.4.2.

R404.1.3.2.1 Concrete foundation stem walls supporting above-grade concrete walls. Foundation stem walls that support above-grade concrete walls shall be designed and constructed in accordance with this section.

[Item 1 remains unchanged.]

2. Stem walls laterally supported at top. Concrete stem walls that are monolithic with slabs-on-ground or are otherwise laterally supported by slabs-on-ground shall be vertically reinforced in accordance with Section R608.6 and Table R608.6(1), R608.6(2) or R608.6(3) for above-grade walls. Where the unbalanced backfill retained by the stem wall is greater than 18 inches (457 mm), the connection between the stem wall and the slab-on-ground, and the portion of the slab-on-ground providing lateral support for the wall shall be designed in accordance with PCA 100 or with ~~accepted engineering practice~~ Section R301.1.3. Where the unbalanced backfill retained by the stem wall is greater than 18 inches (457 mm), the minimum nominal thickness of the wall shall be 6 inches (152 mm).

R404.1.3.2.2 Concrete foundation stem walls supporting light-frame above-grade walls. Concrete foundation stem walls that support light-frame above-grade walls shall be designed and constructed in accordance with this section.

[Item 1 remains unchanged.]

2. Stem walls laterally supported at top. Concrete stem walls that are monolithic with slabs-on-ground or are otherwise laterally supported by slabs-on-ground shall be constructed in accordance with Section R404.1.3. Where the unbalanced backfill retained by the stem wall is greater than 48 inches (1219 mm), the connection between the stem wall and the slab-on-ground, and the portion of the slab-on-ground providing lateral support for the wall, shall be designed in accordance with PCA 100 or in accordance with ~~accepted engineering practice~~ Section R301.1.3.

R404.1.3.3.6.1 Stay-in-place forms. Stay-in-place concrete forms shall comply with this section.

[Items 1 through 3 remain unchanged.]

~~4. Termite protection. In areas where the probability of termite infestation is “very heavy” as indicated by Table R301.2 or Figure R301.2.1, foam plastic insulation shall be permitted below grade on foundation walls in accordance with Section R318.4.~~

~~4.5.~~ Flat ICF wall system forms shall conform to ASTM E2634.

R404.1.5.3 Pier and curtain wall foundations. Use of pier and curtain wall foundations shall be permitted to support *light-frame construction* not more than two *stories* in height, provided that the following requirements are met:

[Items 1 through 4 and 6 through 7 remain unchanged.]

5. Anchorage shall be in accordance with Section R403.1.6, Figure R404.1.5.3, or as specified by ~~engineered~~ *nonprescriptive design* accepted by the *building official*.

R404.1.8 Rubble stone masonry. Rubble stone masonry foundation walls shall have a minimum thickness of 16 inches (406 mm), shall not support an unbalanced backfill exceeding 8 feet (2438 mm) in height, shall not support a soil pressure greater than 30 pounds per square foot per foot (4.71 kPa/m), and shall not be constructed in *Seismic Design Categories D₀, D₁, D₂* or *townhouses* in *Seismic Design Category C*, ~~as established in Figure R301.2(2).~~

R404.1.9.1 Pier cap. *Hollow masonry piers* shall be capped with 4 inches (102 mm) of *solid masonry* or concrete, a masonry cap block, or shall have cavities of the top course filled with concrete or grout. ~~Where required, termite protection for the pier cap shall be provided in accordance with Section R318.~~

R404.1.9.3 Masonry piers supporting braced wall panels. Masonry piers supporting *braced wall panels* shall be designed in accordance with ~~accepted engineering practice~~ [Section R301.1.3](#).

R404.1.9.4 Seismic design of masonry piers. Masonry piers in *dwelling*s located in *Seismic Design Category D₀, D₁ or D₂*, and *townhouses* in *Seismic Design Category C*, shall be designed in accordance with ~~accepted engineering practice~~ [Section R301.1.3](#).

R404.4 Retaining walls. Retaining walls that are not laterally supported at the top and that retain in excess of 48 inches (1219 mm) of unbalanced fill, or retaining walls exceeding 24 inches (610 mm) in height that resist lateral loads in addition to soil, shall be designed in accordance with ~~accepted engineering practice~~ [Section R301.1.3](#) to ensure stability against overturning, sliding, excessive foundation pressure and water uplift. Retaining walls shall be designed for a safety factor of 1.5 against lateral sliding and overturning. This section shall not apply to foundation walls supporting buildings.

R404.5.1 Design. *Precast concrete* foundation walls shall be designed in accordance with ~~accepted engineering practice~~ [Section R301.1.3](#). The design and manufacture of *precast concrete* foundation wall panels shall comply with the materials requirements of Section R402.3 or ACI 318. ~~The panel design drawings shall be prepared by a registered design professional where required by the statutes of the jurisdiction in which the project is to be constructed in accordance with Section R106.1.~~

SECTION R406 FOUNDATION WATERPROOFING AND DAMPPROOFING

R406.2 Concrete and masonry foundation waterproofing. In areas where a high water table or other severe soilwater conditions are known to exist, exterior foundation walls that retain earth and enclose interior spaces and floors below *grade* shall be waterproofed from the finished *grade* to the higher of the top of the footing or 6 inches (152 mm) below the top of the basement floor. Walls shall be waterproofed in accordance with one of the following:

1. Two-ply hot-mopped felts.
2. Fifty-five-pound (25 kg) roll roofing.
- ~~3. Six mil (0.15 mm) polyvinyl chloride.~~
- ~~4. Six mil (0.15 mm) polyethylene.~~
3. Forty-mil (1 mm) polymer-modified asphalt.
4. Sixty-mil (1.5 mm) flexible polymer cement.
5. One-eighth-inch (3 mm) cement-based, fiber-reinforced, waterproof coating.
6. Sixty-mil (1.5 mm) solvent-free liquid-applied synthetic rubber.

SECTION R407 COLUMNS

R407.3 Structural requirements. The columns shall be restrained to prevent lateral displacement at the bottom end. Wood columns shall be not less in nominal size than 4 inches by 4 inches (102 mm by 102 mm). Steel columns shall be not less than 3-inch-diameter (76 mm) Schedule 40 pipe manufactured in accordance with ASTM A53/A53M Grade B or *approved* equivalent.

Exception: ~~In Seismic Design Categories A, B and C,~~ Columns not more than 48 inches (1219 mm) in height on a pier or footing are exempt from the bottom end lateral displacement requirement within under-floor areas enclosed by a continuous foundation. See Figure R502.9.

SECTION R408 UNDER-FLOOR SPACE

Section R408.2

Model code change with existing amendments

The entire section has been reorganized for clarity.

The changes specifically clarify that the 1:150 ventilation rate is only applicable where radon-mitigating construction is required. Also, the ventilation coverings prohibition language from Appendix F have been added for alignment.

R408.2 Under-floor spaces with ventilation openings. Ventilation openings through foundation or exterior walls surrounding the under-floor space shall be provided in accordance with Sections R408.2.1 through R408.2.4.

R408.2.1 Under-floor vapor retarder. The ground surface of the under-floor space shall be covered by a Class I vapor retarder, or other *approved* material, lapped not less than 12 inches (305 mm) at the joints and extended not less than 12 inches (305 mm) up perimeter foundation walls.

R408.2.2 Minimum net area of ventilation openings. For naturally ventilated under-floor spaces in new construction in Baker, Clackamas, Hood River, Multnomah, Polk, Washington and Yamhill counties where radon-mitigating construction is required, the minimum net area of ventilation openings shall be not less than 1 square foot (0.0929 m²) for each 150 square feet (14 m²).

Where radon-mitigating construction is not required and the ground surface is covered in accordance with Section R408.2.1, the minimum net area of ventilation openings shall be not less than 1 square foot (0.0929 m²) for each 1,500 square feet (139 m²) of under-floor area.

R408.2.3 Ventilation opening locations. The required ventilation openings shall be placed to provide cross ventilation of the under-floor space. One ventilation opening shall be within 3 feet (914 mm) of corner of the under-floor space.

Exceptions:

1. Ventilation openings are not required on one side.
2. Ventilation openings in townhouses are not required on two sides where adjoining adjacent townhouses.
3. Ventilation openings are not required where the under-floor space complies with Section R408.3.

R408.2.4 Ventilation opening coverings. Ventilation openings shall be covered for their height and width with any of the following materials provided that the least dimension of the covering shall not exceed 1/4 inch (6.4 mm), and operational louvers are permitted:

1. Perforated sheet metal plates not less than 0.070 inch (1.8 mm) thick.
2. Expanded sheet metal plates not less than 0.047 inch (1.2 mm) thick.
3. Cast-iron grill or grating.
4. Extruded load-bearing brick vents.
5. Hardware cloth of 0.035 inch (0.89 mm) wire or heavier.
6. Corrosion-resistant wire mesh, with the least dimension being 1/8 inch (3.2 mm) thick.

Exceptions:

- ~~1. The total area of ventilation openings shall be permitted to be reduced to 1/1,500 of the under floor area where the ground surface is covered with an approved Class I vapor retarder material.~~
- ~~2. Where the ground surface is covered with an approved Class I vapor retarder material, ventilation openings are not required to be within 3 feet (915 mm) of each external corner of the under floor space provided that the openings are placed to provide cross ventilation of the space.~~

Exception: For naturally ventilated under-floor spaces in new construction in Baker, Clackamas, Hood River, Multnomah, Polk, Washington and Yamhill counties where radon-mitigating construction is required, operable louvers, dampers or other means to temporarily stop the ventilation shall not be permitted.

R408.3 Unvented crawl space. For unvented under-floor spaces, the following items shall be provided:

1. Exposed earth shall be covered with a continuous Class I vapor retarder. Joints of the vapor retarder shall overlap by 6 inches (152 mm) and shall be sealed or taped, or overlapped a minimum of 12 inches (305 mm) where joints are not sealed or taped. The edges of the vapor retarder shall extend not less than 12 inches (305 mm) ~~6 inches (152 mm)~~ up the stem wall and shall be attached and sealed to the stem wall or insulation.
2. One of the following shall be provided for the underfloor space:
 - 2.1. Continuously operated mechanical exhaust ventilation at a rate equal to 1 cubic foot per minute (0.47 L/s) for each 50 square feet (4.7 m²) of *crawl space* floor area, including an air pathway to the common area (such as a duct or transfer grille), and perimeter walls insulated in accordance with Section N1104 of this code.
 - 2.2. *Conditioned air* supply sized to deliver at a rate equal to 1 cubic foot per minute (0.47 L/s) for each 50 square feet (4.7 m²) of underfloor area, including a return air pathway to the common area (such as a duct or transfer grille), and perimeter walls insulated in accordance with Section N1104 of this code.
 - ~~2.3. — Plenum in existing structures complying with Section M1601.5, if under floor space is used as a plenum.~~
 - ~~2.3.2.4.~~ Dehumidification sized in accordance with manufacturer's specifications.

Exception: Unvented crawl spaces are not allowed in new construction in Baker, Clackamas, Hood River, Multnomah, Polk, Washington and Yamhill counties where radon-mitigating construction is required, unless an approved mechanical ventilation system is provided in accordance with the exception in Section AF103.5 and the requirements of Section R408.3 are met.

R408.7 Flood resistance. For buildings located in flood hazard areas as established by the flood plain administrator ~~in Table R301.2:~~

1. Walls enclosing the under-floor space shall be provided with flood openings in accordance with Section R322.2.2.
2. The finished ground level of the under-floor space shall be equal to or higher than the outside finished ground level on at least one side.

Exception: Under-floor spaces that meet the requirements of FEMA TB 11-1.

IRC R408.8 Under-floor vapor retarder. *...Not adopted.*

CHAPTER 5 FLOORS

SECTION R502 WOOD FLOOR FRAMING

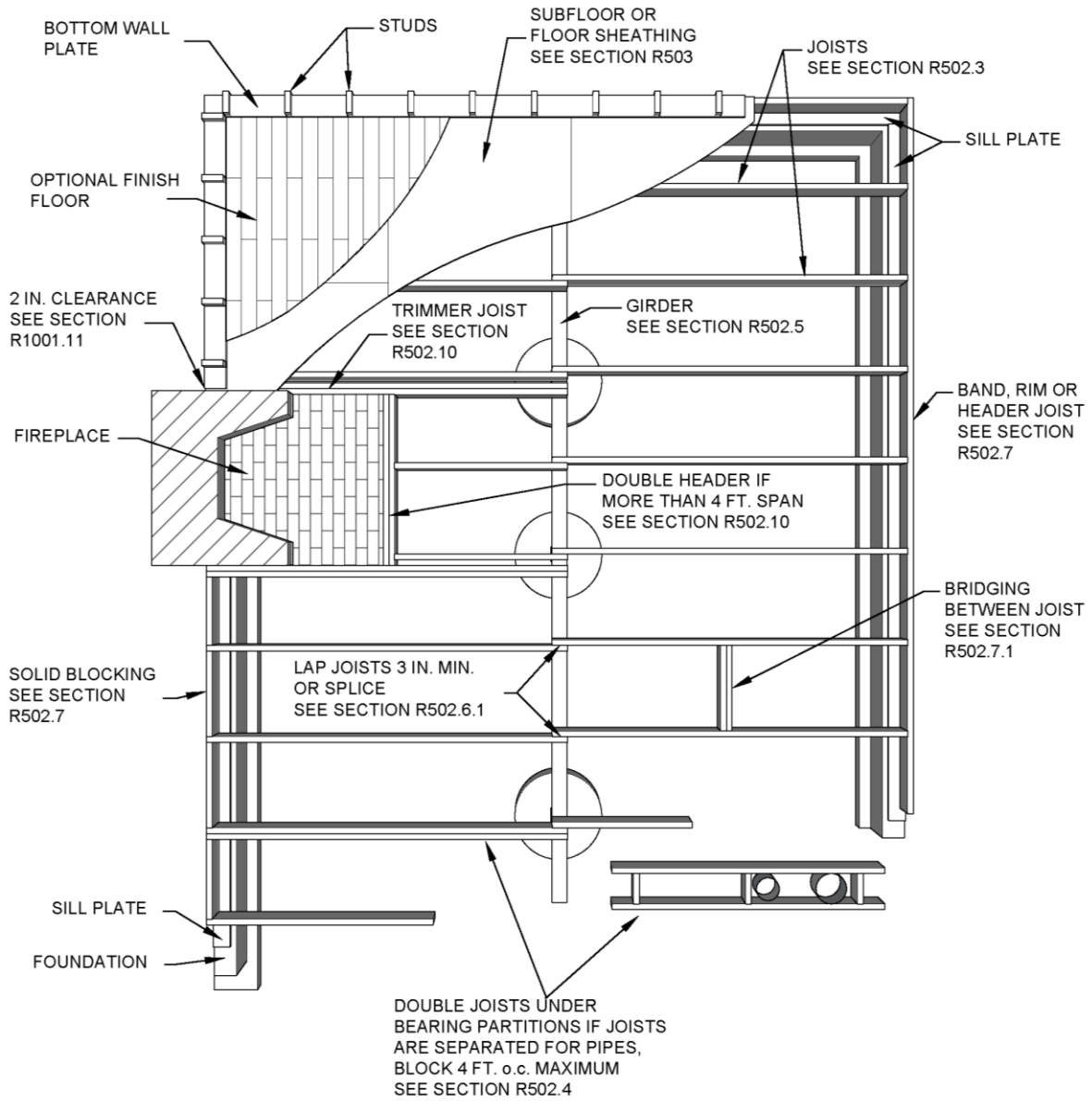

For SI: 1 inch = 25.4 mm, 1 foot = 304.8 mm.

**FIGURE R502.2
FLOOR CONSTRUCTION**

R502.5 Allowable girder and header spans. The allowable spans of girders and headers fabricated of dimension lumber shall not exceed the values set forth in Tables R602.7(1), R602.7(2) and R602.7(3). [Floor system girders supporting only one floor shall be permitted to be designed in accordance with Table R502.5.](#)

**TABLE R502.5
ALLOWABLE SPANS FOR GIRDERS SUPPORTING ONLY ONE FLOOR^a**

SIZE OF WOOD GIRDERS ^b		SPACING BETWEEN GIRDERS OR BETWEEN GIRDERS AND LOAD-BEARING WALLS ^c					
		4 feet	6 feet	8 feet	10 feet	12 feet	16 feet
4 × 4	-	5'-0"	4'-0"	3'-6"	3'-0"	2'-10"	2'-6"
4 × 6	-	7'-6"	6'-0"	5'-6"	4'-6"	4'-4"	4'-0"
4 × 8	6 × 6	10'-0"	8'-6"	7'-6"	6'-6"	6'-0"	5'-0"
4 × 10	6 × 8	13'-0"	10'-6"	9'-6"	8'-6"	7'-6"	5'-6"
4 × 12	6 × 10	16'-0"	12'-6"	11'-0"	10'-0"	9'-4"	8'-0"

For SI: 1 inch = 25.4 mm, 1 foot = 304.8 mm, 1 pound per square foot = 47.88 Pa.

a. Allowable spans shall be permitted to be interpolated between tributary loads shown in the table. Spans are based on a 40 pounds per square foot floor live load. Span and girder sizes shall be permitted to be computed independently of Table R502.5 in accordance with Section R301.1.3.

b. Spans are based on No. 2 grade lumber.

c. The spacing is based on the tributary joist span(s) to the girder and shall be obtained by adding the floor joist span lengths on each side of the girder and dividing by two.

R502.7 Lateral restraint at supports. Joists shall be supported laterally at the ends by full-depth solid blocking not less than 2 inches (51 mm) nominal in thickness; or by attachment to a full-depth header, band or rim joist, or to an adjoining stud or shall be otherwise provided with lateral support to prevent rotation.

Exceptions:

1.—Trusses, *structural composite lumber*, structural glued-laminated members and I-joists shall be supported laterally as required by the manufacturer's recommendations.

~~2.—In Seismic Design Categories D₀, D₁ and D₂, lateral restraint shall be provided at each intermediate support.~~

R502.8.2 Engineered wood products. Cuts, notches and holes bored in trusses, *structural composite lumber*, structural glued-laminated members, cross-laminated timber members or I-joists are prohibited except where permitted by the manufacturer's recommendations or where the effects of such alterations are specifically considered in the design of the member ~~by a registered design professional.~~

R502.9 Fastening. Floor framing shall be nailed in accordance with Table R602.3(1). Where posts and beam or girder construction is used to support floor framing, positive connections shall be provided to ensure against ~~uplift and~~ lateral displacement. [See Figure R502.9.](#)

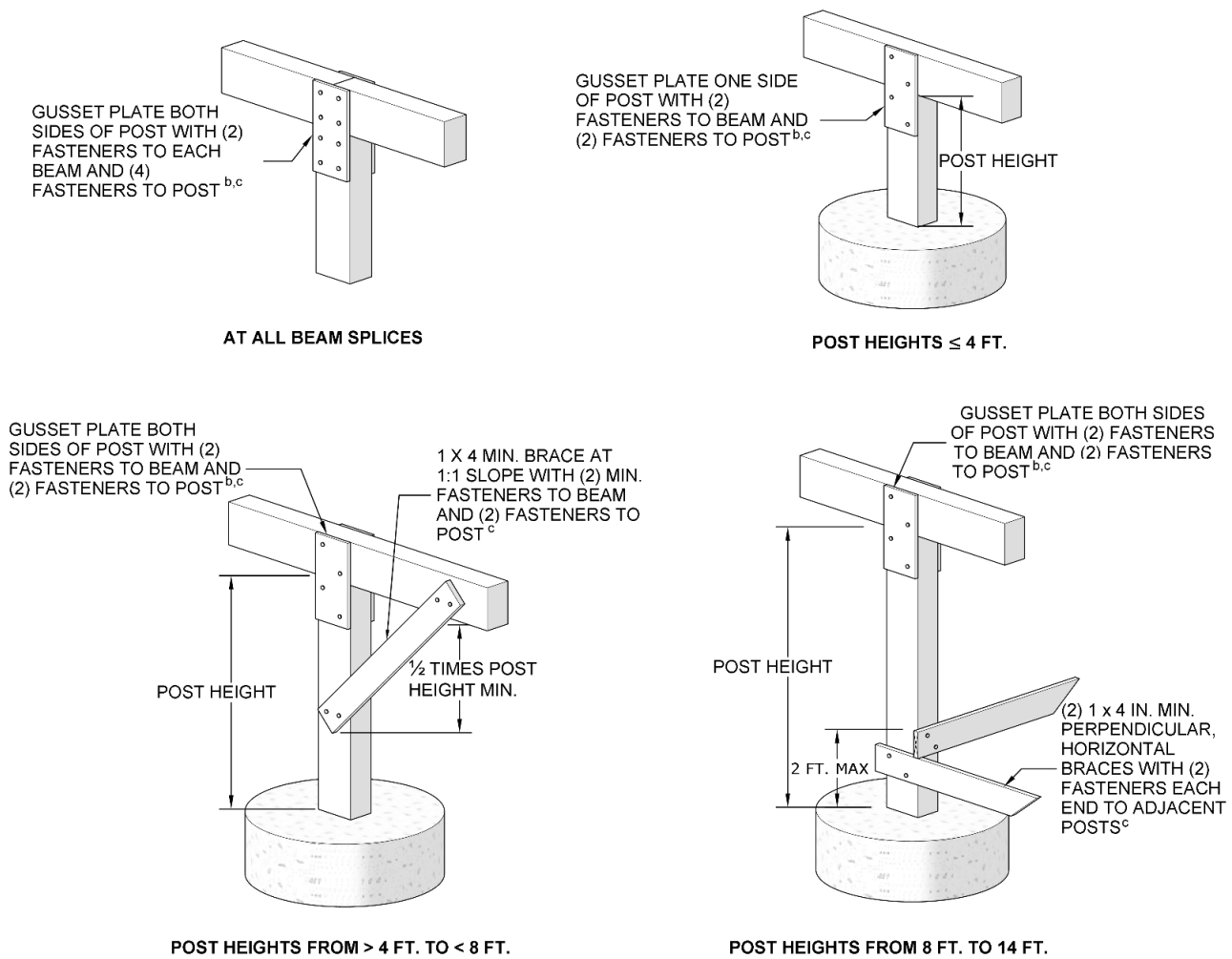

For SI: 1 inch = 25.4 mm, 1 foot = 304.8 mm.

- The connections prescribed by this figure are deemed to comply with the requirements of Sections R407.3 and R502.9.
- Gusset plates shall be minimum ½-inch wood structural panel with minimum width equal to the post width and minimum height equal to two times the beam depth. 1 × 4 minimum wood lumber or 16 gage minimum metal plate are an acceptable alternative to ½-inch wood structural panel.
- Fasteners shall be minimum 8d nail with 1½-inch minimum penetration and ¾-inch minimum end/edge distance. No. 8 × 2 ½-inch staples are an acceptable alternative to 8d nails.
- Manufactured post-to-beam or post-to-footing connectors installed in accordance with the manufacturer's installation instructions are deemed to comply with the requirements of Sections R407.3 and R502.9.

FIGURE R502.9
POST AND BEAM CONNECTIONS^{a,d}

R502.11.1 Design. Wood trusses shall be designed in accordance with [Section R301.1.3](#) ~~approved engineering practice~~. The design and manufacture of metal-plate-connected wood trusses shall comply with ANSI/TPI 1. ~~The truss design drawings shall be prepared by a registered design professional where required by the statutes of the jurisdiction in which the project is to be constructed in accordance with Section R106.1.~~

R502.11.3 Alterations to trusses. Truss members and components shall not be cut, notched, spliced or otherwise altered in any way ~~without the approval of a registered design professional~~ except where specifically permitted by the manufacturer's recommendations or where the effects of such alterations are specifically considered in the design of the truss member. Alterations resulting in the addition of load that exceeds the design load for the truss, shall not be permitted without verification that the truss is capable of supporting the additional loading.

SECTION R506 CONCRETE FLOORS (ON GROUND)

R506.2.3 Vapor retarder Ground cover. A ~~minimum 10 mil (0.010 inch; 0.254 mm) vapor retarder conforming to ASTM E1745 Class A requirements with joints lapped not less than 6 inches (152 mm)~~ 6-mil (0.006 inch; 152 μm) polyethylene or approved Class I vapor retarder with joints lapped not less than 12 inches (305 mm), shall be placed between the concrete floor slab and the base course or the prepared subgrade where a base course does not exist.

Exception: The ground cover vapor retarder is not required for the following:

1. Garages, utility buildings and other unheated *accessory structures*.
2. For unheated storage rooms having an area of less than 70 square feet (6.5 m²) and carports.
3. Driveways, walks, patios and other flatwork not likely to be enclosed and heated at a later date.
4. Where *approved* by the *building official*, based on local site conditions.

SECTION R507 EXTERIOR DECKS

R507.1 Decks. Wood-framed decks shall be in accordance with this section. ~~Decks shall be designed for the live load required in Section R301.5 or the ground snow load indicated in Table R301.2, whichever is greater. For decks using materials and conditions not prescribed in this section, refer to Section R301.~~

Section R507 – Model code change:

Numerous updates to the exterior deck design, construction and material provisions from both the 2021 IRC and 2024 IRC.

R507.2.1 Wood materials. Wood ~~structural members shall be protected from decay where required by Sections R317.1 and R317.2 materials shall be No. 2 grade or better lumber, preservative treated in accordance with Section R317, or approved, naturally durable lumber, and termite protected where required in accordance with Section R318.~~ Where design in accordance with Section R301 is provided, wood structural members shall be designed using the wet service factor defined in AWC NDS. Sawn lumber for joists, beams and posts shall be No. 2 grade or better. Cuts, notches and drilled holes of preservative-treated wood members shall be treated in accordance with Section R317.1.1. ~~All preservative treated wood products in contact with the ground shall be labeled for such usage.~~

IRC R507.2.2.4 Termite resistance. *...Not adopted.*

R507.2.3 Fasteners and connectors. Metal fasteners and connectors used for all decks shall be in accordance with Section R317.3 and Table R507.2.3. Holes for bolts shall be drilled to a diameter of 1/32 inch (0.8 mm) to 1/16 inch (2 mm) larger than the bolt diameter. Connectors shall be installed in accordance with the manufacturer's instructions.

**TABLE R507.2.3
FASTENER AND CONNECTOR SPECIFICATIONS FOR DECKS^{a,b}**

ITEM	MATERIAL	MINIMUM FINISH/COATING	ALTERNATE FINISH/COATING ^{c,e}
Nails and <u>glulam rivets</u>	In accordance with ASTM F1667	Hot-dipped galvanized per ASTM A153, <u>Class D for 3/8-inch diameter and less</u>	Stainless steel, silicon bronze or copper
Bolts ^e	In accordance with ASTM A307 (bolts), ASTM A563 (nuts), ASTM F844 (washers)	Hot-dipped galvanized per ASTM A153, Class C (Class D for 3/8-inch diameter and less) or mechanically galvanized per ASTM B695, Class 55 or 410 stainless steel	Stainless steel, silicon bronze or copper
Lag screws ^d (including nuts and washers)			
Metal connectors	Per manufacturer's specification	ASTM A653 type G185 zinc-coated galvanized steel or post hot-dipped galvanized per ASTM A123 providing a minimum average coating weight of 2.0 oz./ft ² (total both sides)	Stainless steel

For SI: 1 inch = 25.4 mm, 1 foot = 304.8 mm.

- a. Equivalent materials, coatings and finishes shall be permitted.
- b. Fasteners and connectors exposed to salt water or located within 300 feet of a salt water shoreline shall be stainless steel.

~~e. Holes for bolts shall be drilled a minimum 1/32 inch and a maximum 1/16 inch larger than the bolt.~~

~~d. Lag screws 1/2 inch and larger shall be predrilled to avoid wood splitting per the National Design Specification (NDS) for Wood Construction.~~

~~c, e. Stainless-steel-driven fasteners shall be in accordance with ASTM F1667.~~

R507.3 Footings. Decks shall be supported on concrete footings or other *approved* structural systems designed to accommodate all loads in accordance with Section R301. Deck footings shall be sized to carry the imposed loads from the deck structure to the ground as shown in Figure R507.3.

Exceptions:

- ~~1. Footings shall not be required for free-standing decks consisting of joists directly supported on grade over their entire length.~~
- ~~2. Footings shall not be required for free-standing decks that meet all of the following criteria:~~
 - ~~2.1. The joists bear directly on precast concrete pier blocks at grade without support by beams or posts.~~
 - ~~2.2. The area of the deck does not exceed 200 square feet (18.6 m²).~~
 - ~~2.3. The walking surface is not more than 20 inches (508 mm) above grade at any point within 36 inches (914 mm) measured horizontally from the edge.~~

R507.3.1 Minimum size. The minimum size of concrete deck footings shall be in accordance with Table R507.3.1, based on the tributary area and allowable soil-bearing pressure in accordance with Table R401.4.1.

**TABLE R507.3.1
MINIMUM FOOTING SIZE FOR DECKS**

LIVE OR GROUND SNOW LOAD ^b (psf)	TRIBUTARY AREA ^e (ft ²)	LOAD-BEARING VALUE OF SOILS ^{a, c, d} (psf)								
		1,500 ^e			2,000 ^e			≥ 3,000 ^e		
		Side of a square footing (inches)	Diameter of a round footing (inches)	Plain concrete thickness (inches) ^f	Side of a square footing (inches)	Diameter of a round footing (inches)	Plain concrete thickness (inches) ^f	Side of a square footing (inches)	Diameter of a round footing (inches)	Plain concrete thickness (inches) ^f

[The rest of the table not shown here remains unchanged.]

For SI: 1 inch = 25.4 mm, 1 square foot = 0.0929 m², 1 pound per square foot = 0.0479 kPa.

- a. Interpolation permitted, extrapolation not permitted.
- b. Based on highest load case: Dead + Live or Dead + Snow.
- c. Footing dimensions shall allow complete bearing of the post.
- d. If the support is a brick or CMU pier, the footing shall have a minimum 2-inch projection on all sides.
- e. Area, in square feet, of deck surface supported by post and footings.
- ~~f. Minimum thickness shall only apply to plain concrete footings.~~

Section R507.4 – Model code changes and new amendments:

- The model code expanded the deck post height by adding the tributary area supported by a post and the wood species for determination of maximum post height.
- Amended by adopting 2024 IRC approved changes requiring “approved” connectors and not just “manufactured” connectors.
- Also amended by adopting 2024 IRC approved changes eliminating unnecessary language regarding other footings as Section R507.3 already addresses “other approved structural systems.”

R507.4 Deck posts. For single-level decks, wood post size shall be in accordance with Table R507.4.

R507.4.1 Deck post to deck footing connection. Where posts bear on concrete footings in accordance with Section R403 and Figure R507.3, lateral restraint shall be provided by approved ~~manufactured~~ connectors or a minimum post embedment of 12 inches (305 mm) in surrounding soils or concrete piers. ~~Other footing systems shall be permitted.~~

Exception: Where expansive, compressible, shifting or other questionable soils are present, surrounding soils shall not be relied on for lateral support.

**TABLE R507.4
DECK POST HEIGHT**

LOADS (psf) ^b	POST SPECIES ^c	POST SIZE ^d	TRIBUTARY AREA (ft ²) ^{g, h}							
			20	40	60	80	100	120	140	160
			MAXIMUM DECK POST HEIGHT ^a (feet-inches)							
40 live load	Southern pine	4 × 4	14-0	13-8	11-0	9-5	8-4	7-5	6-9	6-2
		4 × 6	14-0	14-0	13-11	12-0	10-8	9-8	8-10	8-2
		6 × 6	14-0	14-0	14-0	14-0	14-0	14-0	14-0	14-0
		8 × 8	14-0	14-0	14-0	14-0	14-0	14-0	14-0	14-0
	Douglas fir ^e Hem-fir ^e Spruce-pine-fir ^e	4 × 4	14-0	13-6	10-10	9-3	8-0	7-0	6-2	5-3
		4 × 6	14-0	14-0	13-10	11-10	10-6	9-5	8-7	7-10
		6 × 6	14-0	14-0	14-0	14-0	14-0	14-0	14-0	14-0
		8 × 8	14-0	14-0	14-0	14-0	14-0	14-0	14-0	14-0
	Redwood ^f Western cedars ^f Ponderosa pine ^f Red pine ^f	4 × 4	14-0	13-2	10-3	8-1	5-8	NP	NP	NP
		4 × 6	14-0	14-0	13-6	11-4	9-9	8-4	6-9	4-7
		6 × 6	14-0	14-0	14-0	14-0	14-0	14-0	13-7	9-7
		8 × 8	14-0	14-0	14-0	14-0	14-0	14-0	14-0	14-0
50 ground snow load	Southern pine	4 × 4	14-0	12-2	9-10	8-5	7-5	6-7	5-11	5-4
		4 × 6	14-0	14-0	12-6	10-9	9-6	8-7	7-10	7-3
		6 × 6	14-0	14-0	14-0	14-0	14-0	14-0	14-0	13-4
		8 × 8	14-0	14-0	14-0	14-0	14-0	14-0	14-0	14-0
	Douglas fir ^e Hem-fir ^e Spruce-pine-fir ^e	4 × 4	14-0	12-1	9-8	8-2	7-1	6-2	5-3	4-2
		4 × 6	14-0	14-0	12-4	10-7	9-4	8-4	7-7	6-11
		6 × 6	14-0	14-0	14-0	14-0	14-0	14-0	14-0	12-10
		8 × 8	14-0	14-0	14-0	14-0	14-0	14-0	14-0	14-0
	Redwood ^f Western cedars ^f Ponderosa pine ^f Red pine ^f	4 × 4	14-0	11-8	9-0	6-10	3-7	NP	NP	NP
		4 × 6	14-0	14-0	12-0	10-0	8-6	7-0	5-3	NP
		6 × 6	14-0	14-0	14-0	14-0	14-0	14-0	10-8	2-4
		8 × 8	14-0	14-0	14-0	14-0	14-0	14-0	14-0	14-0
60 ground snow load	Southern pine	4 × 4	14-0	11-1	8-11	7-7	6-7	5-10	5-2	4-6
		4 × 6	14-0	14-0	11-4	9-9	8-7	7-9	7-1	6-6
		6 × 6	14-0	14-0	14-0	14-0	14-0	14-0	12-9	11-2
		8 × 8	14-0	14-0	14-0	14-0	14-0	14-0	14-0	14-0
	Douglas fir ^e Hem-fir ^e Spruce-pine-fir ^e	4 × 4	14-0	10-11	8-8	7-3	6-2	5-0	3-7	NP
		4 × 6	14-0	13-11	11-2	9-7	8-4	7-5	6-8	5-11
		6 × 6	14-0	14-0	14-0	14-0	14-0	14-0	12-2	10-2
		8 × 8	14-0	14-0	14-0	14-0	14-0	14-0	14-0	14-0
	Redwood ^f Western cedars ^f Ponderosa pine ^f Red pine ^f	4 × 4	14-0	10-6	7-9	4-7	NP	NP	NP	NP
		4 × 6	14-0	13-7	10-9	8-9	7-0	4-9	NP	NP
		6 × 6	14-0	14-0	14-0	14-0	14-0	9-9	NP	NP
		8 × 8	14-0	14-0	14-0	14-0	14-0	14-0	14-0	14-0
70 ground snow load	Southern pine	4 × 4	14-0	10-2	8-2	6-11	5-11	5-2	4-4	3-4
		4 × 6	14-0	12-11	10-5	8-11	7-10	7-1	6-5	5-10
		6 × 6	14-0	14-0	14-0	14-0	14-0	12-9	10-11	8-7
		8 × 8	14-0	14-0	14-0	14-0	14-0	14-0	14-0	14-0
	Douglas fir ^e Hem-fir ^e Spruce-pine-fir ^e	4 × 4	14-0	10-1	7-11	6-6	5-3	3-7	NP	NP
		4 × 6	14-0	12-10	10-3	8-9	7-7	6-8	5-10	4-11
		6 × 6	14-0	14-0	14-0	14-0	14-0	12-2	9-9	5-9
		8 × 8	14-0	14-0	14-0	14-0	14-0	14-0	14-0	14-0
	Redwood ^f Western cedars ^f Ponderosa pine ^f Red pine ^f	4 × 4	14-0	9-5	6-5	NP	NP	NP	NP	NP
		4 × 6	14-0	12-6	9-8	7-7	5-3	NP	NP	NP
		6 × 6	14-0	14-0	14-0	14-0	10-8	NP	NP	NP
		8 × 8	14-0	14-0	14-0	14-0	14-0	14-0	14-0	14-0

(continued)

TABLE R507.4—continued
DECK POST HEIGHT

For SI: 1 inch = 25.4 mm, 1 foot = 304.8 mm, 1 pound per square foot = 0.0479 kPa. NP = Not Permitted.

- a. Measured from the underside of the beam to the top of footing or pier.
- b. 10 psf dead load. Snow load not assumed to be concurrent with live load.
- c. No. 2 grade, wet service factor included.
- d. Notched deck posts shall be sized to accommodate beam size in accordance with Section R507.5.2.
- e. Includes incising factor.
- f. Incising factor not included.
- g. Area, in square feet, of deck surface supported by post and footings.
- h. Interpolation permitted. Extrapolation not permitted.

R507.5 Deck beams. Maximum allowable spans for wood deck beams, as shown in Figure R507.5, shall be in accordance with [Tables R507.5\(1\) through R507.5\(4\)](#) and based on the joist span and cantilever length as shown in [Figure R507.6](#). Beam plies shall be fastened together with two rows of 10d (3-inch × 0.128-inch) nails minimum at 16 inches (406 mm) on center along each edge. ~~Beams shall be permitted to cantilever at each end up to one-fourth of the actual beam span.~~ Deck beams of other materials shall be permitted where designed in accordance with [Section R103.1.3](#) ~~accepted engineering practices~~.

R507.5.1 Deck beam bearing. ~~Beams and individual beam plies of built-up beams shall be continuous between bearing locations and continuous across bearing locations supporting beam cantilevers. Beams shall be permitted to cantilever beyond bearing locations up to one-fourth of the actual beam span.~~ The ends of beams shall have not less than 1½ inches (38 mm) of bearing on wood or metal and not less than 3 inches (76 mm) of bearing on concrete or masonry for the entire width of the beam. ~~Where multiple span beams bear on intermediate posts, each ply must have full bearing on the post in accordance with Figures R507.5.1(1) and R507.5.1(2).~~

R507.5.2 Deck beam connection to supports. Deck beams shall be ~~connected to supporting members to prevent lateral~~ attached to supports in a manner capable of transferring vertical loads and resisting horizontal displacement. Deck beam connections to wood posts shall be in accordance with [Figures R507.5.2\(1\) and R507.5.2\(2\)](#) ~~R507.5.1(1) and R507.5.1(2)~~. Manufactured post-to-beam connectors shall be sized for the post and beam sizes. Bolts shall have washers under the head and nut.

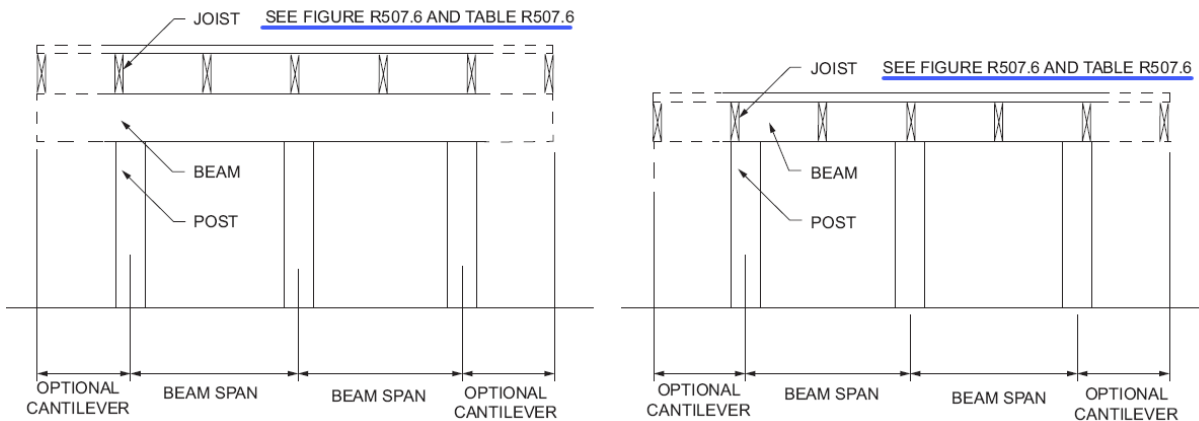

FIGURE R507.5
TYPICAL DECK [BEAM](#) JOIST SPANS

Table R507.5(1) – Model code change and new amendment

The deck beam span table has been split into multiple tables providing spans for given deck live or snow loads. Single- and multi-ply spans as well as options for support of cantilevered deck joists are listed.

The tables were amended by adopting 2024 IRC approved changes: See the reason statement for the approved proposal: [RB183-22](#).

**TABLE R507.5(1)
MAXIMUM DECK BEAM SPAN—40 PSF LIVE LOAD^c**

BEAM SPECIES ^d	JOIST SPAN (feet)	JOIST SPAN LENGTH AND JOIST CANTILEVER LENGTH ^{a,i} (feet and feet)									
	6	6 & 0	6 & 1.5	8 & 1	8 & 2	10 & 2.5	12 & 2	12 & 3	14 & 3.5	16 & 4	18 & 4.5
Southern pine	8		8 & 0	8 & 1	8 & 2						
	10			10 & 0	10 & 1	10 & 2.5					
	12				12 & 0	12 & 1	12 & 2	12 & 3			
	14					14 & 0	14 & 1	14 & 2	14 & 3.5		
	16						16 & 0	16 & 1	16 & 2.5	16 & 4	
	18							18 & 0	18 & 1.5	18 & 3	18 & 4.5
	BEAM SIZE ^e	MAXIMUM DECK BEAM SPAN LENGTH (feet-inches) ^{a, b, f}									
Douglas fir-larch ^g Hem-fir ^g Spruce-pine-fir	1-2 x 6	4-10	4-7	4-3	4-0	3-7	3-5	3-3	3-0	2-10	2-8
	1-2 x 8	6-4	5-11	5-6	5-1	4-7	4-4	4-2	3-10	3-7	3-5
	1-2 x 10	7-6	7-0	6-6	6-0	5-5	5-2	4-11	4-7	4-3	4-0
	1-2 x 12	8-8	8-3	7-8	7-1	6-4	6-1	5-10	5-5	5-0	4-9
	2-2 x 6	7-4	6-11	6-5	5-11	5-4	5-1	4-10	4-6	4-3	4-0
	2-2 x 8	9-4	8-9	8-2	7-7	6-9	6-5	6-2	5-9	5-4	5-0
	2-2 x 10	11-0	10-4	9-8	9-0	8-0	7-8	7-4	6-9	6-4	6-0
	2-2 x 12	13-0	12-2	11-4	10-7	9-5	9-0	8-7	8-0	7-5	7-0
	3-2 x 6	9-0	8-6	7-11	7-5	6-8	6-4	6-1	5-8	5-3	4-11
	3-2 x 8	11-7	10-11	10-3	9-6	8-6	8-1	7-9	7-2	6-8	6-4
Redwood ^h Western cedars ^h Ponderosa pine ^h Red pine ^h	1-2 x 6	4-5	4-1	3-9	3-6	3-0	2-10	2-8	2-5	2-3	2-1
	1-2 x 8	5-11	5-6	5-1	4-8	4-0	3-9	3-6	3-2	2-11	2-9
	1-2 x 10	7-1	6-8	6-3	5-10	5-1	4-9	4-6	4-1	3-9	3-6
	1-2 x 12	8-3	7-9	7-3	6-9	6-0	5-9	5-6	5-0	3-9	3-6
	2-2 x 6	6-6	6-1	5-8	5-3	4-9	4-6	4-4	3-11	3-7	3-3
	2-2 x 8	8-8	8-2	7-7	7-1	6-4	6-0	5-9	5-2	4-8	4-4
	2-2 x 10	10-8	10-0	9-3	8-7	7-9	7-4	7-0	6-6	6-0	5-6
	2-2 x 12	12-4	11-7	10-9	10-0	8-11	8-6	8-2	7-7	7-1	6-8
	3-2 x 6	8-2	7-8	7-2	6-8	6-0	5-9	5-6	5-1	4-9	4-6
	3-2 x 8	10-11	10-3	9-6	8-10	7-11	7-7	7-3	6-8	6-3	5-11

For SI: 25.4 mm, 1 foot = 304.8 mm, 1 pound per square foot = 0.0479 kPa, 1 pound = 0.454 kg.

- a. Interpolation ~~allowed~~ permitted for conditions with zero joist cantilever length. Extrapolation is not ~~allowed~~ permitted.
- b. Beams supporting a single span of joists with or without cantilever.
- c. Dead load = 10 psf, L/Δ = 360 at main span, L/Δ = 180 at cantilever. Snow load not assumed to be concurrent with live load.
- d. No. 2 grade, wet service factor included.
- e. Beam depth shall be equal to or greater than the depth of intersecting joist for a flush beam connection.
- f. Beam cantilevers are limited to the adjacent beam's span divided by 4.
- g. Includes incising factor.
- h. Incising factor not included.
- i. Deck joist span as shown in Figure R507.5.
- ~~j. For calculation of effective deck joist span, the actual joist span length shall be multiplied by the joist span factor in accordance with Table R507.5(5).~~

**TABLE R507.5(2)
MAXIMUM DECK BEAM SPAN—50 PSF GROUND SNOW LOAD^c**

BEAM SPECIES ^d	JOIST SPAN (feet)	JOIST SPAN LENGTH & JOIST CANTILEVER LENGTH ^{a,i} (feet & feet)									
	6	6 & 0	6 & 1.5								
	8		8 & 0	8 & 1	8 & 2						
	10			10 & 0	10 & 1	10 & 2.5					
	12				12 & 0	12 & 1	12 & 2	12 & 3			
	14					14 & 0	14 & 1	14 & 2	14 & 3.5		
	16						16 & 0	16 & 1	16 & 2.5	16 & 4	
	18							18 & 0	18 & 1.5	18 & 3	18 & 4.5
	BEAM SIZE ^e	MAXIMUM DECK BEAM SPAN LENGTH ^{a, b, f} (feet-inches)									
Southern pine	1-2 x 6	4-9	4-6	4-2	3-11	3-6	3-4	3-2	2-11	2-9	2-7
	1-2 x 8	6-2	5-9	5-4	4-11	4-5	4-2	4-0	3-9	3-6	3-3
	1-2 x 10	7-2	6-9	6-3	5-10	5-3	5-0	4-9	4-5	4-2	3-11
	1-2 x 12	8-6	8-0	7-5	6-11	6-2	5-11	5-8	5-3	4-11	4-7
	2-2 x 6	7-1	6-8	6-2	5-9	5-2	4-11	4-9	4-4	4-1	3-10
	2-2 x 8	9-1	8-6	7-11	7-4	6-7	6-3	6-0	5-7	5-2	4-11
	2-2 x 10	10-9	10-1	9-5	8-9	7-10	7-5	7-1	6-7	6-2	5-10
	2-2 x 12	12-9	11-11	11-1	10-3	9-2	8-9	8-5	7-9	7-3	6-10
	3-2 x 6	8-3	7-11	7-6	7-2	6-6	6-2	5-11	5-6	5-1	4-10
	3-2 x 8	11-0	10-5	9-10	9-3	8-3	7-10	7-6	6-11	6-6	6-2
Douglas fir-larch ^g Hem-fir ^g Spruce-pine-fir	3-2 x 10	13-6	12-8	11-9	10-11	9-9	8-4	8-11	8-3	7-9	7-3
	3-2 x 12	15-11	14-11	13-11	12-11	11-6	11-0	10-6	9-9	9-1	8-7
	1-2 x 6	4-3	4-0	3-8	3-5	2-11	2-9	2-7	2-4	2-2	2-0
	1-2 x 8	5-9	5-4	4-11	4-7	3-11	3-8	3-5	3-1	2-10	2-8
	1-2 x 10	7-0	6-7	6-1	5-8	4-11	4-8	4-5	4-0	3-8	3-5
	1-2 x 12	8-1	7-7	7-1	6-7	5-11	5-7	5-4	4-10	4-6	4-2
	2-2 x 6	6-5	6-0	5-7	5-2	4-7	4-4	4-2	3-10	3-5	3-2
	2-2 x 8	8-6	8-0	7-5	6-11	6-2	5-11	5-8	5-0	4-7	4-2
	2-2 x 10	10-5	9-9	9-1	8-5	7-7	7-3	6-11	6-4	5-10	5-4
	2-2 x 12	12-1	11-4	10-7	9-10	8-9	8-4	8-0	7-5	6-11	6-6
Redwood ^h Western cedars ^h Ponderosa pine ^h Red pine ^h	3-2 x 6	8-0	7-6	7-0	6-6	5-9	5-6	5-3	4-11	4-7	4-4
	3-2 x 8	10-8	10-0	9-4	8-8	7-9	7-5	7-1	6-6	6-1	5-8
	3-2 x 10	13-1	12-3	11-5	10-7	9-6	9-1	8-8	8-0	7-6	7-0
	3-2 x 12	15-2	14-3	13-3	12-4	11-0	10-6	10-1	9-4	8-9	8-3
	1-2 x 6	4-4	4-1	3-9	3-6	3-0	2-10	2-8	2-5	2-3	2-1
	1-2 x 8	5-6	5-2	4-10	4-6	4-0	3-9	3-6	3-2	2-11	2-9
	1-2 x 10	6-9	6-4	5-11	5-6	4-11	4-8	4-6	4-1	3-9	3-6
	1-2 x 12	7-10	7-4	6-10	6-4	5-8	5-5	5-2	4-10	4-6	4-3
	2-2 x 6	6-6	6-1	5-8	5-3	4-8	4-6	4-4	3-11	3-6	3-3
	2-2 x 8	8-2	7-8	7-2	6-8	5-11	5-8	5-5	5-0	4-8	4-3
2-2 x 10	10-0	9-5	8-9	8-2	7-3	6-11	6-8	6-2	5-9	5-5	
2-2 x 12	11-8	10-11	10-2	9-5	8-5	8-0	7-8	7-2	6-8	6-3	
3-2 x 6	7-5	7-1	6-9	6-5	5-11	5-8	5-5	5-0	4-8	4-5	
3-2 x 8	9-10	9-4	8-10	8-4	7-5	7-1	6-10	6-0	5-11	5-7	
3-2 x 10	12-6	11-9	10-11	10-2	9-1	8-8	8-4	7-8	7-2	6-9	
3-2 x 12	14-7	13-8	12-9	11-10	10-7	10-1	9-8	8-11	8-4	7-10	

For SI: 25.4 mm, 1 foot = 304.8 mm, 1 pound per square foot = 0.0479 kPa, 1 pound = 0.454 kg.

- Interpolation ~~allowed~~ permitted for conditions with zero joist cantilever length. Extrapolation is not ~~allowed~~ permitted.
- Beams supporting a single span of joists with or without cantilever.
- Dead load = 10 psf, $L/\Delta = 360$ at main span, $L/\Delta = 180$ at cantilever. Snow load not assumed to be concurrent with live load.
- No. 2 grade, wet service factor included.
- Beam depth shall be equal to or greater than the depth of intersecting joist for a flush beam connection.
- Beam cantilevers are limited to the adjacent beam's span divided by 4.
- Includes incising factor.
- Incising factor not included.
- Deck joist span as shown in Figure R507.5.
- ~~For calculation of effective deck joist span, the actual joist span length shall be multiplied by the joist span factor in accordance with Table R507.5(5).~~

**TABLE R507.5(3)
MAXIMUM DECK BEAM SPAN—60 PSF GROUND SNOW LOAD^c**

	JOIST SPAN (feet)	JOIST SPAN LENGTH AND JOIST CANTILEVER LENGTH ^{a,i} (feet and feet)																								
		6 & 0	6 & 1.5	8 & 1	8 & 2	10 & 0	10 & 1	10 & 2.5	12 & 0	12 & 1	12 & 2	12 & 3	14 & 0	14 & 1	14 & 2	14 & 3.5	16 & 0	16 & 1	16 & 2.5	16 & 4	18 & 0	18 & 1.5	18 & 3	18 & 4.5		
BEAM SPECIES^d	BEAM SIZE^e	MAXIMUM DECK BEAM SPAN LENGTH^{a, b, f} (feet-inches)																								
Southern pine	1-2 x 6	4-5	4-2	3-10	3-7	3-3	3-1	2-11	2-9	2-6	2-5															
	1-2 x 8	5-7	5-3	4-11	4-7	4-1	3-11	3-9	3-5	3-3	3-0															
	1-2 x 10	6-8	6-3	5-10	5-5	4-10	4-7	4-5	4-1	3-10	3-7															
	1-2 x 12	7-11	7-5	6-11	6-5	5-9	5-6	5-3	4-10	4-6	4-3															
	2-2 x 6	6-7	6-2	5-9	5-4	4-9	4-6	4-4	4-0	3-9	3-7															
	2-2 x 8	8-4	7-10	7-4	6-10	6-1	5-10	5-7	5-2	4-10	4-6															
	2-2 x 10	9-10	9-4	8-8	8-1	7-3	6-11	6-7	6-1	5-8	5-4															
	2-2 x 12	11-9	11-0	10-3	9-6	8-6	8-1	7-9	7-2	6-9	6-4															
	3-2 x 6	7-9	7-5	7-1	6-9	6-0	5-9	5-6	5-1	4-9	4-6															
	3-2 x 8	10-4	9-9	9-1	8-6	7-8	7-3	6-11	6-5	6-0	5-8															
3-2 x 10	12-5	11-8	10-11	10-2	9-1	8-8	8-3	7-8	7-2	6-9																
3-2 x 12	14-8	13-9	12-10	11-11	10-8	10-2	9-9	9-0	8-5	7-11																
Douglas fir-larch ^g Hem-fir ^g Spruce-pine-fir	1-2 x 6	3-11	3-8	3-4	3-1	2-8	2-6	2-4	2-2	2-0	1-10															
	1-2 x 8	5-5	5-0	4-6	4-1	3-6	3-3	3-1	2-10	2-7	2-5															
	1-2 x 10	6-6	6-1	5-7	5-2	4-6	4-3	4-0	3-7	3-4	3-2															
	1-2 x 12	7-7	7-1	6-7	6-1	5-5	5-1	4-10	4-5	4-1	3-10															
	2-2 x 6	5-10	5-6	5-1	4-9	4-3	4-0	3-10	3-5	3-1	2-10															
	2-2 x 8	7-11	7-5	6-11	6-5	5-9	5-4	5-0	4-6	4-1	3-9															
	2-2 x 10	9-7	9-0	8-5	7-10	7-0	6-8	6-4	5-9	5-2	4-10															
	2-2 x 12	11-2	10-6	9-9	9-1	8-1	7-9	7-5	6-10	6-4	5-10															
	3-2 x 6	7-4	6-11	6-5	6-0	5-4	5-1	4-11	4-6	4-2	3-10															
	3-2 x 8	9-10	9-3	8-7	8-0	7-2	6-10	6-6	6-1	5-6	5-0															
3-2 x 10	12-1	11-4	10-7	9-10	8-9	8-4	8-0	7-5	6-11	6-5																
3-2 x 12	13-6	13-2	11-9	11-5	10-2	9-9	9-4	8-7	8-1	7-7																
Redwood ^h Western cedars ^h Ponderosa pine ^h Red pine ^h	1-2 x 6	4-0	3-9	3-5	3-2	2-9	2-7	2-5	2-2	2-0	1-11															
	1-2 x 8	5-2	4-10	4-6	4-2	3-7	3-4	3-2	2-11	2-8	2-6															
	1-2 x 10	6-2	5-10	5-5	5-1	4-6	4-3	4-1	3-8	3-5	3-3															
	1-2 x 12	7-3	6-10	6-4	5-11	5-3	5-0	4-10	4-5	4-2	3-11															
	2-2 x 6	5-11	5-7	5-2	4-10	4-4	4-1	3-11	3-6	3-2	2-11															
	2-2 x 8	7-6	7-1	6-7	6-2	5-6	5-3	5-0	4-7	4-2	3-10															
	2-2 x 10	9-3	8-8	8-1	7-6	6-9	6-5	6-2	5-8	5-4	4-11															
	2-2 x 12	10-8	10-1	9-5	8-9	7-10	7-6	7-2	6-7	6-2	5-10															
	3-2 x 6	6-11	6-8	6-4	6-1	5-5	5-2	5-0	4-7	4-3	3-11															
	3-2 x 8	9-3	8-9	8-3	7-9	6-11	6-7	6-4	5-10	5-5	5-3															
3-2 x 10	11-8	10-11	10-2	9-5	8-5	8-0	7-8	7-3	6-8	6-3																
3-2 x 12	13-6	12-8	11-9	10-11	9-9	8-4	8-11	8-3	7-9	7-3																

For SI: 25.4 mm, 1 foot = 304.8 mm, 1 pound per square foot = 0.0479 kPa, 1 pound = 0.454 kg.

- Interpolation ~~allowed~~ permitted for conditions with zero joist cantilever length. Extrapolation is not ~~allowed~~ permitted.
- Beams supporting a single span of joists with or without cantilever.
- Dead load = 10 psf, $L/\Delta = 360$ at main span, $L/\Delta = 180$ at cantilever. Snow load not assumed to be concurrent with live load.
- No. 2 grade, wet service factor included.
- Beam depth shall be equal to or greater than the depth of intersecting joist for a flush beam connection.
- Beam cantilevers are limited to the adjacent beam's span divided by 4.
- Includes incising factor.
- Incising factor not included.
- Deck joist span as shown in Figure R507.5.
- ~~For calculation of effective deck joist span, the actual joist span length shall be multiplied by the joist span factor in accordance with Table R507.5(5).~~

**TABLE R507.5(4)
MAXIMUM DECK BEAM SPAN—70 PSF GROUND SNOW LOAD^c**

	JOIST SPAN (feet)	JOIST SPAN LENGTH AND JOIST CANTILEVER LENGTH ^{a,i} (feet and feet)																								
		6 & 0	6 & 1.5	8 & 1	8 & 2	10 & 0	10 & 1	10 & 2.5	12 & 0	12 & 1	12 & 2	12 & 3	14 & 0	14 & 1	14 & 2	14 & 3.5	16 & 0	16 & 1	16 & 2.5	16 & 4	18 & 0	18 & 1.5	18 & 3	18 & 4.5		
6																										
8																										
10																										
12																										
14																										
16																										
18																										
BEAM SPECIES ^d	BEAM SIZE ^e	MAXIMUM DECK BEAM SPAN LENGTH ^{a, b, f} (feet-inches)																								
Southern pine	1-2 x 6	4-2	3-11	3-7	3-4	3-0	2-10	2-9	2-6	2-4	2-3															
	1-2 x 8	5-4	4-11	4-8	4-3	3-10	3-8	3-6	3-3	3-0	2-10															
	1-2 x 10	6-2	5-10	5-5	5-1	4-6	4-4	4-2	3-10	3-7	3-4															
	1-2 x 12	7-4	6-11	6-5	6-0	5-4	5-1	4-11	4-6	4-3	4-0															
	2-2 x 6	6-3	5-9	5-4	5-0	4-6	4-3	4-1	3-9	3-6	3-4															
	2-2 x 8	7-10	7-4	6-10	6-4	5-8	5-5	5-2	4-10	4-6	4-3															
	2-2 x 10	9-6	8-9	8-2	7-7	6-9	6-5	6-2	5-8	5-4	5-0															
	2-2 x 12	10-11	10-3	9-7	8-11	8-0	7-7	7-3	6-9	6-3	5-11															
	3-2 x 6	7-4	7-0	6-7	6-3	5-7	5-4	5-1	4-9	4-5	4-2															
	3-2 x 8	9-10	9-3	8-7	8-0	7-2	6-10	6-6	6-0	5-8	5-4															
3-2 x 10	11-7	10-11	10-2	9-6	8-6	8-1	7-9	7-2	6-8	6-4																
3-2 x 12	13-9	12-11	12-0	11-2	10-0	9-6	9-1	8-5	7-11	7-5																
Douglas fir-larch ^g Hem-fir ^g Spruce-pine-fir	1-2 x 6	3-8	3-5	3-1	2-10	2-5	2-3	2-2	2-0	1-10	1-9															
	1-2 x 8	4-10	4-7	4-1	3-8	3-2	3-0	2-10	2-7	2-5	2-4															
	1-2 x 10	6-1	5-8	5-2	4-9	4-1	3-10	3-8	3-4	3-1	2-11															
	1-2 x 12	7-0	6-7	6-1	5-8	5-0	4-9	4-6	4-1	3-10	3-7															
	2-2 x 6	5-6	5-2	4-10	4-6	4-0	3-8	3-5	3-1	2-10	2-7															
	2-2 x 8	7-4	6-11	6-5	6-0	5-3	4-11	4-7	4-1	3-8	3-5															
	2-2 x 10	8-11	8-5	7-10	7-4	6-6	6-2	5-10	5-2	4-9	4-5															
	2-2 x 12	10-6	9-10	9-2	8-6	7-7	7-3	6-11	6-4	5-9	5-4															
	3-2 x 6	6-11	6-6	6-0	5-7	5-0	4-9	4-7	4-2	3-9	3-5															
	3-2 x 8	9-3	8-8	8-1	7-6	6-8	6-4	6-1	5-6	5-0	4-7															
3-2 x 10	11-3	10-7	9-10	9-2	8-2	7-10	7-6	6-11	6-4	5-10																
3-2 x 12	13-2	12-4	11-6	10-8	9-7	9-2	8-9	8-1	7-7	7-1																
Redwood ^h Western cedars ^h Ponderosa pine ^h Red pine ^h	1-2 x 6	3-9	3-6	3-2	2-11	2-6	2-4	2-3	2-0	1-11	1-9															
	1-2 x 8	4-10	4-6	4-2	3-10	3-3	3-1	2-11	2-8	2-6	2-4															
	1-2 x 10	5-10	5-6	5-1	4-9	4-2	3-11	3-9	3-5	3-2	3-0															
	1-2 x 12	6-9	6-4	5-11	5-6	4-11	4-8	4-6	4-2	3-11	3-8															
	2-2 x 6	5-7	5-3	4-11	4-7	4-1	3-9	3-6	3-2	2-11	2-8															
	2-2 x 8	7-1	6-8	6-2	5-9	5-2	4-11	4-8	4-2	3-10	3-6															
	2-2 x 10	8-8	8-2	7-7	7-1	6-4	6-0	5-9	5-4	4-10	4-6															
	2-2 x 12	10-0	9-5	8-9	8-2	7-4	7-0	6-8	6-2	5-9	5-5															
	3-2 x 6	6-8	6-4	6-0	5-8	5-1	4-10	4-8	4-3	3-10	3-6															
	3-2 x 8	8-10	8-4	7-9	7-3	6-5	6-2	5-11	5-5	5-1	4-8															
3-2 x 10	10-10	10-2	9-6	8-10	7-11	7-6	7-2	6-8	6-3	5-11																
3-2 x 12	12-7	11-10	11-0	10-3	9-2	8-9	8-4	7-9	7-3	6-10																

For SI: 25.4 mm, 1 foot = 304.8 mm, 1 pound per square foot = 0.0479 kPa, 1 pound = 0.454 kg.

a. Interpolation ~~allowed~~ permitted for conditions with zero joist cantilever length. Extrapolation is not ~~allowed~~ permitted.

b. Beams supporting a single span of joists with or without cantilever.

c. Dead load = 10 psf, $L/\Delta = 360$ at main span, $L/\Delta = 180$ at cantilever. Snow load not assumed to be concurrent with live load.

d. No. 2 grade, wet service factor included.

e. Beam depth shall be equal to or greater than the depth of intersecting joist for a flush beam connection.

f. Beam cantilevers are limited to the adjacent beam's span divided by 4.

g. Includes incising factor.

h. Incising factor not included.

i. Deck joist span as shown in Figure R507.5.

~~j. For calculation of effective deck joist span, the actual joist span length shall be multiplied by the joist span factor in accordance with Table R507.5(S).~~

IRC Table R507.5(5) Joist Span Factors for CalculatingNot adopted.

R507.6.1 Deck joist bearing. The ends of joists shall have not less than 1½ inches (38 mm) of bearing length on wood or metal and not less than 3 inches (76 mm) of bearing length on concrete or masonry over its entire width. Joists bearing on top of a multiple-ply beam or ledger shall be fastened in accordance with Table R602.3(1). Joists bearing on top of a single-ply beam or ledger shall be attached by a mechanical connector. Joist framing into the side of a beam or ledger board shall be supported by *approved* joist hangers.

Table R507.6 – Model code change:

Deck joist options have been added for decks with large ground snow loads. Cantilever spans are now specifically based on maximum joist spans.

**TABLE R507.6
MAXIMUM DECK JOIST SPANS**

LOAD ^a (psf)	JOIST SPECIES ^b	JOIST SIZE	ALLOWABLE JOIST SPAN ^{b, c} (feet-inches)			MAXIMUM CANTILEVER ^{d, f} (feet-inches)							
			Joist spacing (inches)			Joist back span ^g (feet)							
			12	16	24	4	6	8	10	12	14	16	18
40 live load	Southern pine	2 × 6	9-11	9-0	7-7	1-0	1-6	1-5	NP	NP	NP	NP	NP
		2 × 8	13-1	11-10	9-8	1-0	1-6	2-0	2-6	2-3	NP	NP	NP
		2 × 10	16-2	14-0	11-5	1-0	1-6	2-0	2-6	3-0	3-4	3-4	NP
		2 × 12	18-0	16-6	13-6	1-0	1-6	2-0	2-6	3-0	3-6	4-0	4-1
	Douglas fir-larch ^e Hem-fir ^e Spruce-pine-fir ^e	2 × 6	9-6	8-4	6-10	1-0	1-6	1-4	NP	NP	NP	NP	NP
		2 × 8	12-6	11-1	9-1	1-0	1-6	2-0	2-3	2-0	NP	NP	NP
		2 × 10	15-8	13-7	11-1	1-0	1-6	2-0	2-6	3-0	3-3	NP	NP
		2 × 12	18-0	15-9	12-10	1-0	1-6	2-0	2-6	3-0	3-6	3-11	3-11
	Redwood ^f Western cedars ^f Ponderosa pine ^f Red pine ^f	2 × 6	8-10	8-0	6-10	1-0	1-4	1-1	NP	NP	NP	NP	NP
		2 × 8	11-8	10-7	8-8	1-0	1-6	2-0	1-11	NP	NP	NP	NP
		2 × 10	14-11	13-0	10-7	1-0	1-6	2-0	2-6	3-0	2-9	NP	NP
		2 × 12	17-5	15-1	12-4	1-0	1-6	2-0	2-6	3-0	3-6	3-8	NP
50 ground snow load	Southern pine	2 × 6	9-2	8-4	7-4	1-0	1-6	1-5	NP	NP	NP	NP	NP
		2 × 8	12-1	11-0	9-5	1-0	1-6	2-0	2-5	2-3	NP	NP	NP
		2 × 10	15-5	13-9	11-3	1-0	1-6	2-0	2-6	3-0	3-1	NP	NP
		2 × 12	18-0	16-2	13-2	1-0	1-6	2-0	2-6	3-0	3-6	3-10	3-10
	Douglas fir-larch ^e Hem-fir ^e Spruce-pine-fir ^e	2 × 6	8-10	8-0	6-8	1-0	1-6	1-4	NP	NP	NP	NP	NP
		2 × 8	11-7	10-7	8-11	1-0	1-6	2-0	2-3	NP	NP	NP	NP
		2 × 10	14-10	13-3	10-10	1-0	1-6	2-0	2-6	3-0	3-0	NP	NP
		2 × 12	17-9	15-5	12-7	1-0	1-6	2-0	2-6	3-0	3-6	3-8	NP
	Redwood ^f Western cedars ^f Ponderosa pine ^f Red pine ^f	2 × 6	8-3	7-6	6-6	1-0	1-4	1-1	NP	NP	NP	NP	NP
		2 × 8	10-10	9-10	8-6	1-0	1-6	2-0	1-11	NP	NP	NP	NP
		2 × 10	13-10	12-7	10-5	1-0	1-6	2-0	2-6	2-9	NP	NP	NP
		2 × 12	16-10	14-9	12-1	1-0	1-6	2-0	2-6	3-0	3-5	3-5	NP
60 ground snow load	Southern pine	2 × 6	8-8	7-10	6-10	1-0	1-6	1-5	NP	NP	NP	NP	NP
		2 × 8	11-5	10-4	8-9	1-0	1-6	2-0	2-4	NP	NP	NP	NP
		2 × 10	14-7	12-9	10-5	1-0	1-6	2-0	2-6	2-11	2-11	NP	NP
		2 × 12	17-3	15-0	12-3	1-0	1-6	2-0	2-6	3-0	3-6	3-7	NP
	Douglas fir-larch ^e Hem-fir ^e Spruce-pine-fir ^e	2 × 6	8-4	7-6	6-2	1-0	1-6	1-4	NP	NP	NP	NP	NP
		2 × 8	10-11	9-11	8-3	1-0	1-6	2-0	2-2	NP	NP	NP	NP
		2 × 10	13-11	12-4	10-0	1-0	1-6	2-0	2-6	2-10	NP	NP	NP
		2 × 12	16-6	14-3	11-8	1-0	1-6	2-0	2-6	3-0	3-5	3-5	NP
	Redwood ^f Western cedars ^f Ponderosa pine ^f Red pine ^f	2 × 6	7-9	7-0	6-2	1-0	1-4	NP	NP	NP	NP	NP	NP
		2 × 8	10-2	9-3	7-11	1-0	1-6	2-0	1-11	NP	NP	NP	NP
		2 × 10	13-0	11-9	9-7	1-0	1-6	2-0	2-6	2-7	NP	NP	NP
		2 × 12	15-9	13-8	11-2	1-0	1-6	2-0	2-6	3-0	3-2	NP	NP

(continued)

**TABLE R507.6—continued
MAXIMUM DECK JOIST SPANS**

LOAD ^a (psf)	JOIST SPECIES ^b	JOIST SIZE	ALLOWABLE JOIST SPAN ^{b, c} (feet-inches)			MAXIMUM CANTILEVER ^{d, f} (feet-inches)							
			Joist spacing (inches)			Joist back span ^g (feet)							
			12	16	24	4	6	8	10	12	14	16	18
70 ground snow load	Southern pine	2 × 6	8-3	7-6	6-5	1-0	1-6	1-5	NP	NP	NP	NP	NP
		2 × 8	10-10	9-10	8-2	1-0	1-6	2-0	2-2	NP	NP	NP	NP
		2 × 10	13-9	11-11	9-9	1-0	1-6	2-0	2-6	2-9	NP	NP	NP
		2 × 12	16-2	14-0	11-5	1-0	1-6	2-0	2-6	3-0	3-5	3-5	NP
	Douglas fir-larch ^e Hem-fir ^e Spruce-pine-fir ^e	2 × 6	7-11	7-1	5-9	1-0	1-6	NP	NP	NP	NP	NP	NP
		2 × 8	10-5	9-5	7-8	1-0	1-6	2-0	2-1	NP	NP	NP	NP
		2 × 10	13-3	11-6	9-5	1-0	1-6	2-0	2-6	2-8	NP	NP	NP
		2 × 12	15-5	13-4	10-11	1-0	1-6	2-0	2-6	3-0	3-3	NP	NP
	Redwood ^f Western cedars ^f Ponderosa pine ^f Red pine ^f	2 × 6	7-4	6-8	5-10	1-0	1-4	NP	NP	NP	NP	NP	NP
		2 × 8	9-8	8-10	7-4	1-0	1-6	1-11	NP	NP	NP	NP	NP
		2 × 10	12-4	11-0	9-0	1-0	1-6	2-0	2-6	2-6	NP	NP	NP
		2 × 12	14-9	12-9	10-5	1-0	1-6	2-0	2-6	3-0	3-0	NP	NP

For SI: 1 inch = 25.4 mm, 1 foot = 304.8 mm, 1 pound per square foot = 0.0479 kPa, 1 pound = 0.454 kg. NP = Not Permitted.

- a. Dead load = 10 psf. Snow load not assumed to be concurrent with live load.
- b. No. 2 grade, wet service factor included.
- c. $L/\Delta = 360$ at main span.
- d. $L/\Delta = 180$ at cantilever with a 220-pound point load applied to end.
- e. Includes incising factor.
- f. Incising factor not included.
- g. Interpolation allowed. Extrapolation is not allowed.

R507.7 Decking. Maximum allowable spacing for joists supporting wood decking, excluding ~~stair treads~~ ~~stairways~~, shall be in accordance with Table R507.7. Wood decking shall be attached to each supporting member with not less than two 8d ~~deformed threaded~~ nails or two No. 8 wood screws. Maximum allowable spacing for joists supporting *plastic composite* decking shall be in accordance with Section R507.2. Other *approved* decking or fastener systems shall be installed in accordance with the manufacturer's installation requirements.

R507.9.1.1 Ledger details. Deck ledgers shall be a minimum 2-inch by 8-inch (51 mm by 203 mm) nominal, pressure-preservative-treated Southern pine, incised pressure-preservative-treated hem-fir, or *approved*, naturally durable, No. 2 grade or better lumber. Deck ledgers shall not support concentrated loads from beams or girders. Deck ledgers shall not be supported on stone or masonry veneer. Deck ledgers shall not be attached to cantilevered floor overhangs.

R507.9.1.3 Ledger to band joist details. ~~Fasteners used in deck ledger connections~~ Where ledgers are fastened in accordance with Table R507.9.1.3(1), fasteners shall ~~be hot-dipped galvanized or stainless steel~~ comply with Section R507.2.3 and shall be installed in accordance with Table R507.9.1.3(2) and Figures R507.9.1.3(1) and R507.9.1.3(2). Holes for 1/2-inch (12.7 mm) lag screws shall be predrilled with two drill bits so that a hole 1/2 inch (12.7 mm) in diameter is drilled through the ledger and sheathing, if present, and a hole 5/16 inch (7.9 mm) to 3/8 inch (9.5 mm) in diameter is drilled through the band joist.

**TABLE R507.9.1.3(1)
DECK LEDGER CONNECTION TO BAND JOIST**

LOAD ^c (psf)	JOIST SPAN ^a (feet)	ON-CENTER SPACING OF FASTENERS ^b (inches)		
		1/2-inch diameter lag screw with 1/2-inch maximum sheathing ^{d, e}	1/2-inch diameter bolt with 1/2-inch maximum sheathing ^e	1/2-inch diameter bolt with 1-inch maximum sheathing ^f
40 live load	6	30	36	36
	8	23	36	36
	10	18	34	29
	12	15	29	24
	14	13	24	21
	16	11	21	18
	18	10	19	16
50 ground snow load	6	29	36	36
	8	22	36	35
	10	17	33	28
	12	14	27	23
	14	12	23	20
	16	11	20	17
	18	9	18	15
60 ground snow load	6	25	36	36
	8	18	35	30
	10	15	28	24
	12	12	23	20
	14	10	20	17
	16	9	17	15
	18	8	15	13
70 ground snow load	6	22	36	35
	8	16	31	26
	10	13	25	21
	12	11	20	17
	14	9	17	15
	16	8	15	13
	18	7	13	11

For SI: 1 inch = 25.4 mm, 1 foot = 304.8 mm, 1 pound per square foot = 0.0479 kPa.

- a. Interpolation permitted. Extrapolation is not permitted.
- b. Ledgers shall be flashed in accordance with Section R703.4 to prevent water from contacting the house band joist.
- c. Dead Load = 10 psf. Snow load shall not be assumed to act concurrently with live load.
- d. The tip of the lag screw shall fully extend beyond the inside face of the band joist. Lag screws shall be full-body diameter screws.
- e. Sheathing shall be wood structural panel or solid sawn lumber.
- f. Sheathing shall be permitted to be wood structural panel, gypsum board, fiberboard, lumber or foam sheathing. Up to 1/2-inch thickness of stacked washers shall be permitted to substitute for up to 1/2 inch of allowable sheathing thickness where combined with wood structural panel or lumber sheathing.

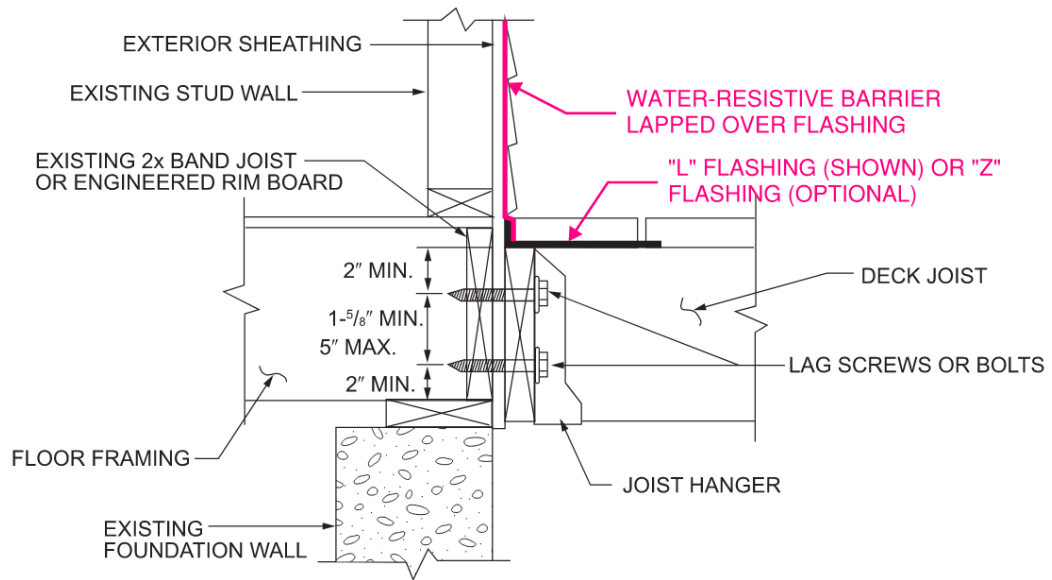

For SI: 1 inch = 25.4 mm.

FIGURE R507.9.1.3(2)
PLACEMENT OF LAG SCREWS AND BOLTS IN BAND JOISTS

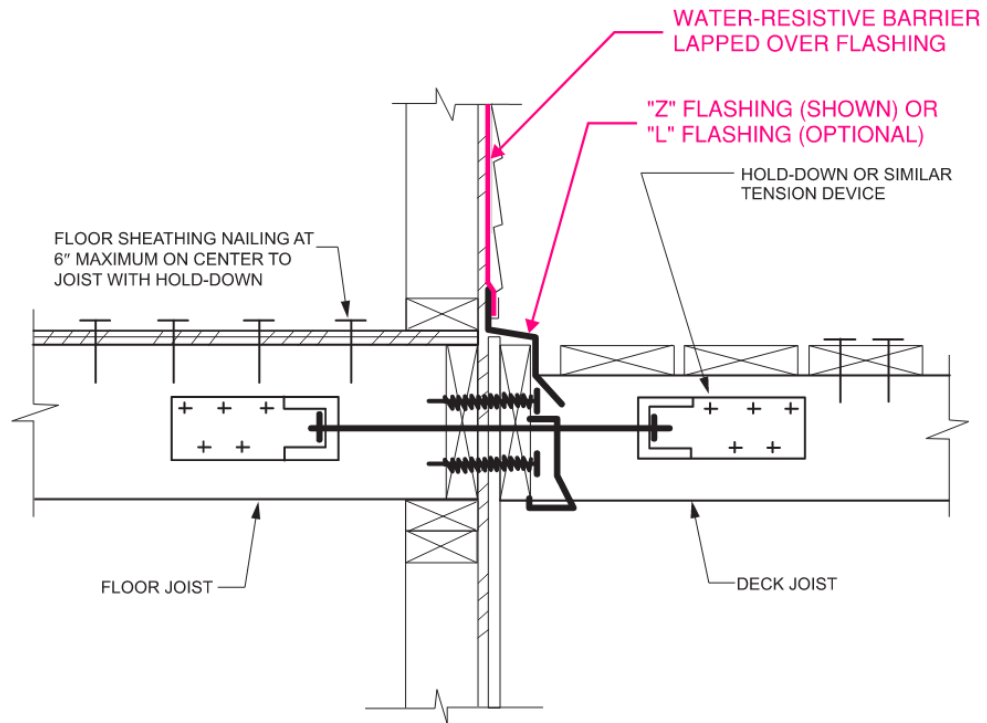

For SI: 1 inch = 25.4 mm.

For SI: 1 inch = 25.4 mm.

FIGURE R507.9.2(1)
DECK ATTACHMENT FOR LATERAL LOADS

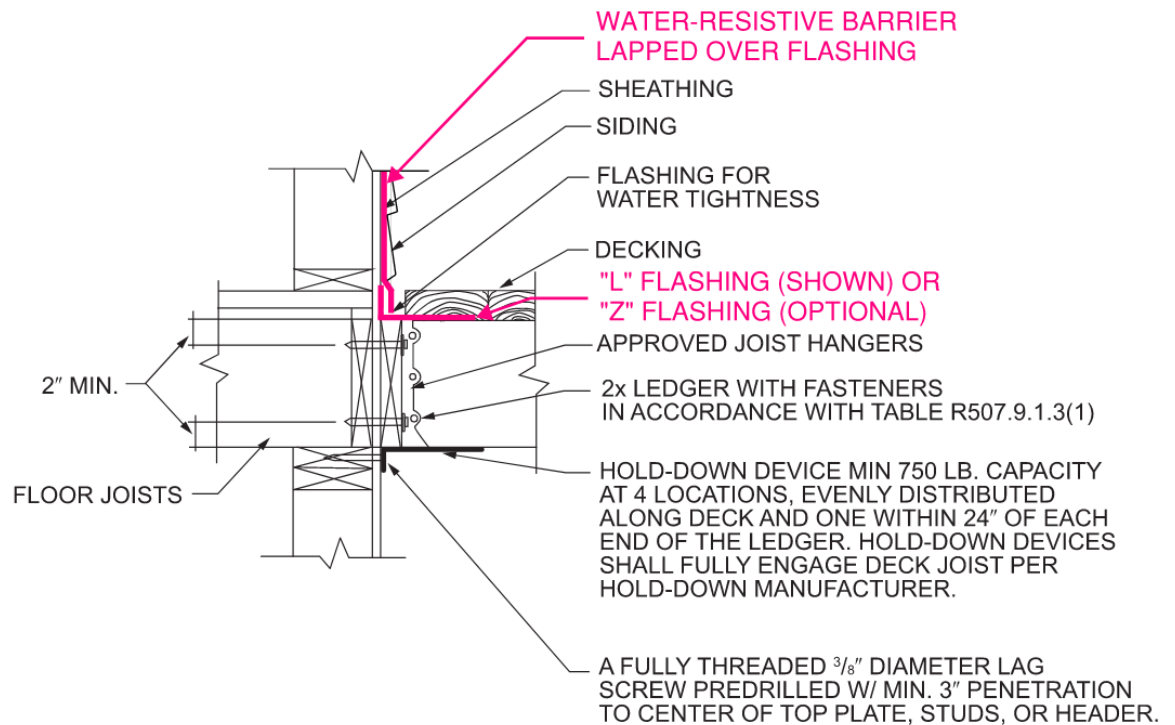

For SI: 1 inch = 25.4 mm, 1 foot = 304.8 mm.

FIGURE R507.9.2(2)
DECK ATTACHMENT FOR LATERAL LOADS

R507.10.2 Wood posts at deck guards. Where 4-inch by 4-inch (102 mm by 102 mm) nominal wood posts support guard loads applied to the top of the guard, such posts shall not be notched at the connection to the supporting structure.

R507.10.4 Other guards. Other *guards* shall be in accordance with either manufacturer's instructions or Section R301.1.3 ~~accepted engineering principles~~.

CHAPTER 6

WALL CONSTRUCTION

SECTION R602 WOOD WALL FRAMING

R602.3 Design and construction. Exterior walls of woodframe construction shall be designed and constructed in accordance with the provisions of this chapter and Figures R602.3(1) and R602.3(2), or in accordance with AWC NDS. Components of exterior walls shall be fastened in accordance with Tables R602.3(1) through R602.3(4). Wall sheathing shall be fastened directly to framing members and, where placed on the exterior side of an exterior wall, ~~shall be capable of resisting the wind pressures listed in Table R301.2.1(1) adjusted for height and exposure using Table R301.2.1(2) and~~ shall conform to the requirements of Table R602.3(3). Wall sheathing used only for exterior wall covering purposes shall comply with Section R703.

Studs shall be continuous from support at the sole plate to a support at the top plate to resist loads perpendicular to the wall. The support shall be a foundation or floor, ceiling or roof *diaphragm* or shall be designed in accordance with [Section R301.1.3](#) ~~accepted engineering practice~~.

Exception: Jack studs, trimmer studs and cripple studs at openings in walls that comply with Tables R602.7(1) and R602.7(2).

R602.3.1 Stud size, height and spacing. The size, height and spacing of studs shall be in accordance with Table R602.3(5).

Exceptions:

1. Utility grade studs shall not be spaced more than 16 inches (406 mm) on center, shall not support more than a roof and ceiling, and shall not exceed 8 feet (2438 mm) in height for exterior walls and *load-bearing walls* or 10 feet (3048 mm) for interior nonload-bearing walls.
2. Where ~~ground snow loads are less than or equal to 25 pounds per square foot (1.2 kPa), and~~ the [basic](#) design wind speed is less than or equal to 130 mph (58.1 m/s), 2-inch by 6-inch (38 mm by 140 mm) studs supporting a roof load with not more than ~~6 feet (1829 mm) 150 pounds per linear foot (2189 N/m) of tributary ground snow load of tributary length~~ shall have a maximum height of 18 feet (5486 mm) where spaced at 16 inches (406 mm) on center, or 20 feet (6096 mm) where spaced at 12 inches (305 mm) on center. Studs shall be No. 2 grade lumber or better.
3. Exterior load-bearing studs not exceeding 12 feet (3658 mm) in height provided in accordance with Table R602.3(6). The minimum number of full-height studs adjacent to openings shall be in accordance with Section R602.7.5. The building shall be located in Exposure B, the roof *live load* shall not exceed 20 psf (0.96 kPa), and the ground snow load shall not exceed ~~30 psf (1.4 kPa)~~ [36 psf \(1.7 kPa\)](#). Studs and plates shall be No. 2 grade lumber or better.

Section R602.3.1 – New amendments:

New allowances for studs taller than the 10 foot limit where ground snow loads exceed the limits of 25 psf and 30 psf, while still meeting the intent on demand vs. capacity in Exceptions 2 and 3.

R602.3.5 Braced wall panel uplift load path. Braced wall panels located at exterior walls that support roof rafters or trusses (including stories below top story) shall have the framing members connected in accordance with one of the following:

1. Fastening in accordance with Table R602.3(1) where:
 - 1.1. The [basic](#) design wind speed does not exceed 115 mph (51 m/s), the wind exposure category is B, the roof pitch is 5:12 or greater, and the roof span is 32 feet (9754 mm) or less.
 - 1.2. The net uplift value at the top of a wall does not exceed 100 plf (146 N/mm). The net uplift value shall be determined in accordance with Section R802.11 and shall be permitted to be reduced by 60 plf (86 N/mm) for each full wall above.
2. Where the net uplift value at the top of a wall exceeds 100 plf (146 N/mm), installing *approved* uplift framing connectors to provide a continuous load path from the top of the wall to the foundation or to a point where the uplift force is 100 plf (146 N/mm) or less. The net uplift value shall be as determined in Item 1.2.
3. Wall sheathing and fasteners designed to resist combined uplift and shear forces in accordance with [Section R301.1.3](#) ~~accepted engineering practice~~.

Table R602.3(1) – Model code change and new amendment:

There have been various updates stemming from related model code changes.
Footnote “a” has been changed for alignment with the new changes to Section R301.1.3.

Errata—April 2024
Item 31 – Footnote “i” does not apply

TABLE R602.3(1)
FASTENING SCHEDULE

ITEM	DESCRIPTION OF BUILDING ELEMENTS	NUMBER AND TYPE OF FASTENER ^{a, b, c}	SPACING AND LOCATION
Roof			
1	Blocking between ceiling joists, rafters or trusses to top plate or other framing below	4-8d box (2½" × 0.113"); or 3-8d common (2½" × 0.131"); or 3-10d box (3" × 0.128"); or 3-3" × 0.131" nails	Toe nail
	Blocking between rafters or truss not at the wall top plates, to rafter or truss	2-8d common (2½" × 0.131"); or 2-3" × 0.131" nails	Each end toe nail
	Flat blocking to truss and web filler	2-16d common (3½" × 0.162"); or 3-3" × 0.131" nails	End nail
		16d common (3½" × 0.162"); or 3" × 0.131" nails	6" o.c. face nail
2	Ceiling joists to top plate	4-8d box (2½" × 0.113"); or 3-8d common (2½" × 0.131"); or 3-10d box (3" × 0.128"); or 3-3" × 0.131" nails	Per joist, toe nail
3	Ceiling joist not attached to parallel rafter, laps over partitions [see Section R802.5.2 and Table R802.5.2(1)]	4-10d box (3" × 0.128"); or 3-16d common (3½" × 0.162"); or 4-3" × 0.131" nails	Face nail
4	Ceiling joist attached to parallel rafter (heel joint) [see Section R802.5.2 and Table R802.5.2(1)]	Table R802.5.2(1)	Face nail
5	Collar tie to rafter, face nail	4-10d box (3" × 0.128"); or 3-10d common (3" × 0.148"); or 4-3" × 0.131" nails	Face nail each rafter
6	Rafter or roof truss to plate	3-16d box (3½" × 0.135"); or 3-10d common (3" × 0.148"); or 4-10d box (3" × 0.128"); or 4-3" × 0.131" nails	2 toe nails on one side and 1 toe nail on opposite side of each rafter or truss ⁱ
7	Roof rafters to ridge, valley or hip rafters or roof rafter to minimum 2" ridge beam	4-16d box (3½" × 0.135"); or 3-10d common (3" × 0.148"); or 4-10d box (3" × 0.128"); or 4-3" × 0.131" nails	Toe nail
		3-16d box (3½" × 0.135"); or 2-16d common (3½" × 0.162"); or 3-10d box (3" × 0.128"); or 3-3" × 0.131" nails	End nail
Wall			
8	Stud to stud (not at braced wall panels)	16d common (3½" × 0.162")	24" o.c. face nail
		10d box (3" × 0.128"); or 3" × 0.131" nails	16" o.c. face nail
9	Stud to stud and abutting studs at intersecting wall corners (at braced wall panels)	16d box (3½" × 0.135"); or 3" × 0.131" nails	12" o.c. face nail
		16d common (3½" × 0.162")	16" o.c. face nail
10	Built-up header (2" to 2" header with ½" spacer)	16d common (3½" × 0.162")	16" o.c. each edge face nail
		16d box (3½" × 0.135")	12" o.c. each edge face nail
11	Continuous header to stud	5-8d box (2½" × 0.113"); or 4-8d common (2½" × 0.131"); or 4-10d box (3" × 0.128")	Toe nail

(continued)

**TABLE R602.3(1)—continued
FASTENING SCHEDULE**

ITEM	DESCRIPTION OF BUILDING ELEMENTS	NUMBER AND TYPE OF FASTENER ^{a, b, c}	SPACING AND LOCATION
Wall			
12	Adjacent full-height stud to end of header	4-16d box (3½" × 0.135"); or 3-16d common (3½" × 0.162"); or 4-10d box (3" × 0.128"); or 4-3" × 0.131" nails	End nail
13	Top plate to top plate	16d common (3½" × 0.162")	16" o.c. face nail
		10d box (3" × 0.128"); or 3" × 0.131" nails	12" o.c. face nail
14	Double top plate splice	8-16d common (3½" × 0.162"); or 12-16d box (3½" × 0.135"); or 12-10d box (3" × 0.128"); or 12-3" × 0.131" nails	Face nail on each side of end joint (minimum 24" lap splice length each side of end joint)
15	Bottom plate to joist, rim joist, band joist or blocking (not at braced wall panels)	16d common (3½" × 0.162")	16" o.c. face nail
		16d box (3½" × 0.135"); or 3" × 0.131" nails	12" o.c. face nail
16	Bottom plate to joist, rim joist, band joist or blocking (at braced wall panel)	3-16d box (3½" × 0.135"); or 2-16d common (3½" × 0.162"); or 4-3" × 0.131" nails	16" o.c. face nail
17	Top or bottom plate to stud	4-8d box (2½" × 0.113"); or 3-16d box (3½" × 0.135"); or 4-8d common (2½" × 0.131"); or 4-10d box (3" × 0.128"); or 4-3" × 0.131" nails	Toe nail
		3-16d box (3½" × 0.135"); or 2-16d common (3½" × 0.162"); or 3-10d box (3" × 0.128"); or 3-3" × 0.131" nails	End nail
18	Top plates, laps at corners and intersections	3-10d box (3" × 0.128"); or 2-16d common (3½" × 0.162"); or 3-3" × 0.131" nails	Face nail
19	1" brace to each stud and plate	3-8d box (2½" × 0.113"); or 2-8d common (2½" × 0.131"); or 2-(3" × 0.131"); or 2-10d box (3" × 0.128")	Face nail
20	1" × 6" sheathing to each bearing	3-8d box (2½" × 0.113"); or 2-8d common (2½" × 0.131"); or 2-10d box (3" × 0.128"); or 2 staples, 1" crown, 16 ga., 1¾" long	Face nail
21	1" × 8" and wider sheathing to each bearing	3-8d box (2½" × 0.113"); or 3-8d common (2½" × 0.131"); or 3-10d box (3" × 0.128"); or 3 staples, 1" crown, 16 ga., 1¾" long	Face nail
		Wider than 1" × 8" 4-8d box (2½" × 0.113"); or 3-8d common (2½" × 0.131"); or 3-10d box (3" × 0.128"); or 4 staples, 1" crown, 16 ga., 1¾" long	

(continued)

**TABLE R602.3(1)—continued
FASTENING SCHEDULE**

ITEM	DESCRIPTION OF BUILDING ELEMENTS	NUMBER AND TYPE OF FASTENER ^{a, b, c}	SPACING AND LOCATION	
Floor				
22	Joist to sill, top plate or girder	4-8d box (2½" × 0.113"); or 3-8d common (2½" × 0.131"); or 3-10d box (3" × 0.128"); or 3-3" × 0.131" nails	Toe nail	
23	Rim joist, band joist or blocking to sill or top plate (roof applications also)	8d box (2½" × 0.113")	4" o.c. toe nail	
		8d common (2½" × 0.131"); or 10d box (3" × 0.128"); or 3" × 0.131" nails	6" o.c. toe nail	
24	1" × 6" subfloor or less to each joist	3-8d box (2½" × 0.113"); or 2-8d common (2½" × 0.131"); or 3-10d box (3" × 0.128"); or 2 staples, 1" crown, 16 ga., 1¾" long	Face nail	
25	2" subfloor to joist or girder	3-16d box (3½" × 0.135"); or 2-16d common (3½" × 0.162")	Blind and face nail	
26	2" planks (plank & beam—floor & roof)	3-16d box (3½" × 0.135"); or 2-16d common (3½" × 0.162")	At each bearing, face nail	
27	Band or rim joist to joist	3-16d common (3½" × 0.162"); or 4-10 box (3" × 0.128"); or 4-3" × 0.131" nails; or 4-3" × 14 ga. staples, 7/16" crown	End nail	
28	Built-up girders and beams, 2-inch lumber layers	20d common (4" × 0.192"); or 10d box (3" × 0.128"); or 3" × 0.131" nails	Nail each layer as follows: 32" o.c. at top and bottom and staggered.	
		And: 2-20d common (4" × 0.192"); or 3-10d box (3" × 0.128"); or 3-3" × 0.131" nails	24" o.c. face nail at top and bottom staggered on opposite sides	
			Face nail at ends and at each splice	
29	Ledger strip supporting joists or rafters	4-16d box (3½" × 0.135"); or 3-16d common (3½" × 0.162"); or 4-10d box (3" × 0.128"); or 4-3" × 0.131" nails	At each joist or rafter, face nail	
30	Bridging or blocking to joist, rafter or truss	2-10d box (3" × 0.128"); or 2-8d common (2½" × 0.131"); or 2-3" × 0.131" nails	Each end, toe nail	
ITEM	DESCRIPTION OF BUILDING ELEMENTS	NUMBER AND TYPE OF FASTENER ^{a, b, c}	SPACING OF FASTENERS	
			Edges ^h (inches)	Intermediate supports ^{c, o} (inches)
Wood structural panels, subfloor, roof and interior wall sheathing to framing and particleboard wall sheathing to framing [see Table R602.3(3) for wood structural panel exterior wall sheathing to wall framing]				
31	3/8" – 1/2"	6d common or deformed (2" × 0.113" × 0.266" head); or 2¾" × 0.113" × 0.266" head nail (subfloor, wall) [‡]	6	12
		8d common (2½" × 0.131") nail (roof); or RSRS-01 (2¾" × 0.113") nail (roof) ^b	6	6 ^f
32	19/32" – 3/4"	8d common (2½" × 0.131") nail (subfloor, wall)	6	12
		8d common (2½" × 0.131") nail (roof); or RSRS-01; (2¾" × 0.113") nail (roof) ^b	6 ^f	6 ^f
		Deformed 2¾" × 0.113" × 0.266" head (wall or subfloor)	6	12
33	7/8" – 1¼"	10d common (3" × 0.148") nail; or (2½" × 0.131" × 0.281" head) deformed nail	6	12

(continued)

**TABLE R602.3(1)—continued
FASTENING SCHEDULE**

ITEM	DESCRIPTION OF BUILDING ELEMENTS	NUMBER AND TYPE OF FASTENER ^{a, b, c}	SPACING AND LOCATION	
Other wall sheathing^g				
34	1/2" structural cellulosic fiberboard sheathing	1 1/2" × 0.120" galvanized roofing nail, 7/16" head diameter; or 1 1/4" long 16 ga. staple with 7/16" or 1" crown	3	6
35	25/32" structural cellulosic fiberboard sheathing	1 3/4" × 0.120" galvanized roofing nail, 7/16" head diameter; or 1 1/4" long 16 ga. staple with 7/16" or 1" crown	3	6
36	1/2" gypsum sheathing ^d	1 1/2" × 0.120" galvanized roofing nail, 7/16" head diameter, or 16 ga.; staple galvanized, 1 1/2" long; 7/16" or 1" crown; or 1 1/4" screws, Type W or S	7	7
37	5/8" gypsum sheathing ^d	1 3/4" × 0.120" galvanized roofing nail, 7/16" head diameter, or 16 ga. staple galvanized, 1 3/8" long; 7/16" or 1" crown; or 1 5/8" screws, Type W or S	7	7
Wood structural panels, combination subfloor underlayment to framing				
38	3/4" and less	Deformed (2" × 0.113") or Deformed (2" × 0.120") nail; or 8d common (2 1/2" × 0.131") nail	6	12
39	7/8" – 1"	8d common (2 1/2" × 0.131") nail; or Deformed (2 1/2" × 0.131"); or Deformed (2 1/2" × 0.120") nail	6	12
40	1 1/8" – 1 1/4"	10d common (3" × 0.148") nail; or Deformed (2 1/2" × 0.131"); or Deformed (2 1/2" × 0.120") nail	6	12

For SI: 1 inch = 25.4 mm, 1 foot = 304.8 mm, 1 mile per hour = 0.447 m/s; 1 ksi = 6.895 MPa.

- a. Nails are smooth-common, box or deformed shanks except where otherwise stated. Nails used for framing and sheathing connections are carbon steel and shall have minimum average bending yield strengths as shown: 80 ksi for shank diameter of 0.192 inch (20d common nail), 90 ksi for shank diameters larger than 0.142 inch but not larger than 0.177 inch, and 100 ksi for shank diameters of 0.142 inch or less. Connections using nails and staples of other materials, such as stainless steel, shall be designed in accordance with Section R301.1.3 by accepted engineering practice or approved under Section R104.11.
- b. RSRS-01 is a Roof Sheathing Ring Shank nail meeting the specifications in ASTM F1667.
- c. Nails shall be spaced at not more than 6 inches on center at all supports where spans are 48 inches or greater.
- d. Four-foot by 8-foot or 4-foot by 9-foot panels shall be applied vertically.
- e. Spacing of fasteners not included in this table shall be based on Table R602.3(2).
- f. For wood structural panel roof sheathing attached to gable end roof framing and to intermediate supports within 48 inches of roof edges and ridges, nails shall be spaced at 4 inches on center where the basic design wind speed is greater than 130 mph in Exposure B or greater than 110 mph in Exposure C.
- g. Gypsum sheathing shall conform to ASTM C1396 and shall be installed in accordance with ASTM C1280 or GA 253. Fiberboard sheathing shall conform to ASTM C208.
- h. Spacing of fasteners on floor sheathing panel edges applies to panel edges supported by framing members and required blocking and at floor perimeters only. Spacing of fasteners on roof sheathing panel edges applies to panel edges supported by framing members and required blocking. Blocking of roof or floor sheathing panel edges perpendicular to the framing members need not be provided except as required by other provisions of this code. Floor perimeter shall be supported by framing members or solid blocking.
- i. Where a rafter is fastened to an adjacent parallel ceiling joist in accordance with this schedule, provide two toe nails on one side of the rafter and toe nails from the ceiling joist to top plate in accordance with this schedule. The toe nail on the opposite side of the rafter shall not be required.

Table R602.3(2) – Model code change:

Footnote “a” has been changed for clarity.

The applicability of this alternate table for roof sheathing attachment is limited to wind speeds less than or equal to 110 mph and requires the fasteners to be installed 3 inches o.c. at all supports.

**TABLE R602.3(2)
ALTERNATE ATTACHMENTS TO TABLE R602.3(1)**

NOMINAL MATERIAL THICKNESS (inches)	DESCRIPTION ^{a, b} OF FASTENER AND LENGTH (inches)	SPACING ^c OF FASTENERS	
		Edges (inches)	Intermediate supports (inches)
Wood structural panels subfloor, roof^g and wall sheathing to framing and particleboard wall sheathing to framing^f			
Up to 1/2	Staple 15 ga. 1 3/4	4	8
	0.097–0.099 Nail 2 1/4	3	6
	Staple 16 ga. 1 3/4	3	6
19/32 and 5/8	0.113 Nail 2	3	6
	Staple 15 and 16 ga. 2	4	8
	0.097–0.099 Nail 2 1/4	4	8
23/32 and 3/4	Staple 14 ga. 2	4	8
	Staple 15 ga. 1 3/4	3	6
	0.097–0.099 Nail 2 1/4	4	8
	Staple 16 ga. 2	4	8
1	Staple 14 ga. 2 1/4	4	8
	0.113 Nail 2 1/4	3	6
	Staple 15 ga. 2 1/4	4	8
	0.097–0.099 Nail 2 1/2	4	8
NOMINAL MATERIAL THICKNESS (inches)	DESCRIPTION ^{a, b} OF FASTENER AND LENGTH (inches)	SPACING ^c OF FASTENERS	
		Edges (inches)	Body of panel ^d (inches)
Floor underlayment; plywood-hardboard-particleboard^f-fiber-cement^h			
Fiber-cement			
1/4	1 1/4 long × 0.099" corrosion-resistant, ring shank nails (finished flooring other than tile)	3	6
	Staple 18 ga., 7/8 long, 1/4 crown (finished flooring other than tile)	3	6
	1 1/4 long × .121 shank × .375 head diameter corrosion-resistant (galvanized or stainless steel) roofing nails (for tile finish)	8	8
	1 1/4 long, No. 8 × .375 head diameter, ribbed wafer-head screws (for tile finish)	8	8
Plywood			
1/4 and 5/16	1 1/4 ring or screw shank nail-minimum 12 1/2 ga. (0.099") shank diameter	3	6
	Staple 18 ga., 7/8, 3/16 crown width	2	5
11/32, 3/8, 15/32 and 1/2	1 1/4 ring or screw shank nail-minimum 12 1/2 ga. (0.099") shank diameter	6	8e
19/32, 5/8, 23/32 and 3/4	1 1/2 ring or screw shank nail-minimum 12 1/2 ga. (0.099") shank diameter	6	8
	Staple 16 ga. 1 1/2	6	8
Hardboard^f			
0.200	1 1/2 long × 0.080" ring-grooved shank underlayment nail	6	6
	1 3/8 long × 0.080" polymer cement-coated sinker nail	6	6
	Staple 18 ga., 7/8 long (plastic coated)	3	6
Particleboard			
1/4	1 1/2 long × 0.099" ring-grooved shank underlayment nail	3	6
	Staple 18 ga., 7/8 long, 3/16 crown	3	6
3/8	2 long × 0.120" ring-grooved shank underlayment nail	6	10
	Staple 16 ga., 1 1/8 long, 3/8 crown	3	6
1/2, 5/8	2 long × 0.120" ring-grooved shank underlayment nail	6	10
	Staple 16 ga., 1 5/8 long, 3/8 crown	3	6

(continued)

For SI: 1 inch = 25.4 mm.

**TABLE R602.3(2)—continued
ALTERNATE ATTACHMENTS TO TABLE R602.3(1)**

- a. Nail is a general description and shall be permitted to be T-head, modified round head or round head.
- b. Staples shall have a minimum crown width of $\frac{7}{16}$ -inch except as noted.
- c. Nails or staples shall be spaced at not more than 6 inches on center at all supports where spans are 48 inches or greater. Nails or staples shall be spaced at not more than 12 inches on center at intermediate supports for floors.
- d. Fasteners shall be placed in a grid pattern throughout the body of the panel.
- e. For 5-ply panels, intermediate nails shall be spaced not more than 12 inches on center each way.
- f. Hardboard underlayment shall conform to CPA/ANSI A135.4.
- g. **Alternate fastening is only permitted** for roof sheathing where the **basic** design wind speed is less than **or equal to 110 mph, and where fasteners are installed 3 inches on center at all supports.**
- h. Fiber-cement underlayment shall conform to ASTM C1288 or ISO 8336, Category C.

**TABLE R602.3(5)
SIZE, HEIGHT AND SPACING OF WOOD STUDS^a**

[The table contents remain unchanged]

For SI: 1 inch = 25.4 mm, 1 foot = 304.8 mm.

- a. Listed heights are distances between points of lateral support placed perpendicular to the plane of the wall. Bearing walls shall be sheathed on not less than one side or bridging shall be installed not greater than 4 feet apart measured vertically from either end of the stud. Increases in unsupported height are permitted where in compliance with Exception 2 of Section R602.3.1 or designed in accordance with [Section R301.1.3](#) **accepted engineering practice.**
- b. Shall not be used in exterior walls.
- c. A habitable attic assembly supported by 2 × 4 studs is limited to a roof span of 32 feet. Where the roof span exceeds 32 feet, the wall studs shall be increased to 2 × 6 or the studs shall be designed in accordance with [Section R301.1.3](#) **accepted engineering practice.**

**TABLE R602.3(6)
ALTERNATE WOOD BEARING WALL STUD SIZE, HEIGHT AND SPACING**

STUD HEIGHT	SUPPORTING	STUD SPACING ^a	BASIC DESIGN WIND SPEED					
			115 mph		130 mph ^b		140 mph ^b	
			Maximum roof/floor span ^c		Maximum roof/floor span ^c		Maximum roof/floor span ^c	
			10 12 ft	20 24 ft	10 12 ft	20 24 ft	10 12 ft	20 24 ft

[The rest of the table contents remains unchanged]

For SI: 1 inch = 25.4 mm, 1 foot = 304.8 mm, 1 mph = 0.447 m/s, 1 pound = 4.448 N. DR = Design Required.

- a. Wall studs not exceeding 16 inches on center shall be sheathed with minimum $\frac{1}{2}$ -inch gypsum board on the interior and $\frac{3}{8}$ -inch wood structural panel sheathing on the exterior. Wood structural panel sheathing shall be attached with 8d (2.5" × 0.131") nails not greater than 6 inches on center along panel edges and 12 inches on center at intermediate supports, and all panel joints shall occur over studs or blocking.
- b. Where the **basic** design wind speed exceeds 115 mph, studs shall be attached to top and bottom plates with connectors having a minimum 300-pound lateral capacity.
- c. The maximum span is applicable to both single- and multiple-span roof and floor conditions. The *roof assembly* shall not contain a habitable attic.

R602.7.2 Rim board headers. Rim board header size, material and span shall be in accordance with Table R602.7(1). Rim board headers shall be constructed in accordance with Figure R602.7.2 and shall be supported at each end by full-height studs. The number of full-height studs at each end shall be not less than the number of studs displaced by half of the header span based on the maximum stud spacing in accordance with Table R602.3(5). Rim board headers supporting concentrated loads shall be designed in accordance with [Section R301.1.3](#) **accepted engineering practice.**

R602.7.4 Nonbearing walls. Load-bearing headers are not required in interior ~~or exterior~~ *nonbearing walls*. A single flat 2-inch by 4-inch (51 mm by 102 mm) member shall be permitted to be used as a header in interior ~~or exterior~~ *nonbearing walls* for openings up to 8 feet (2438 mm) in width if the vertical distance to the parallel nailing surface above is not more than 24 inches (610 mm). For such nonbearing headers, cripples or blocking are not required above the header.

Figure R602.10.1.1 – New amendment

Braced Wall Line (BWL) A dimension has been added for clarity and alignment with Section R602.10.1.1. This is a common misapplication item; designer has flexibility to use any of the listed options in Section R602.10.1.1 for the end of the braced wall line.

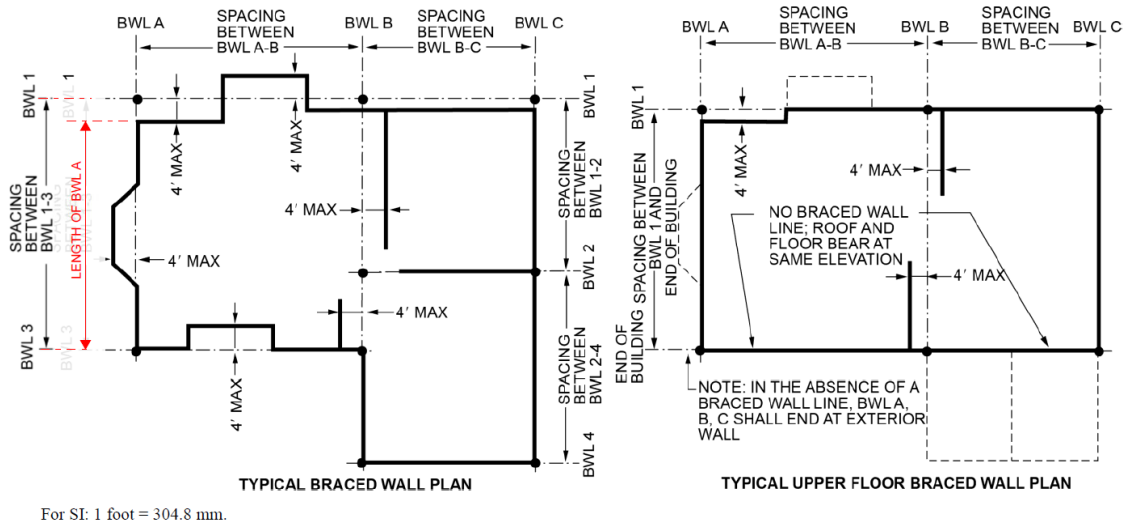

**FIGURE R602.10.1.1
BRACED WALL LINES**

R602.10.1.2 Location of braced wall lines and permitted offsets. ~~Each braced wall line shall be located such that no more than two thirds of the required braced wall panel length is located to one side of the braced wall line. Braced wall panels shall be permitted to be offset up to 4 feet (1219 mm) from the designated braced wall line. Braced wall panels parallel to a braced wall line shall be offset not more than 4 feet (1219 mm) from the designated braced wall line location as shown in Figure R602.10.1.1.~~

Exterior walls parallel to a braced wall line shall be offset not more than 4 feet (1219 mm) from the designated braced wall line location as shown in Figure R602.10.1.1.

Interior walls used as bracing shall be offset not more than 4 feet (1219 mm) from a braced wall line through the interior of the building as shown in Figure R602.10.1.1.

Where all of the braced wall panels along a braced wall line occur within a single line, the braced wall line shall be located at the aligned braced wall panels, and an offset of the braced wall line is not permitted.

**TABLE R602.10.1.3
BRACED WALL LINE SPACING**

APPLICATION	CONDITION	BUILDING TYPE	BRACED WALL LINE SPACING CRITERIA	
			Maximum Spacing	Exception to Maximum Spacing
Wind bracing	Basic design wind speed < 140 mph	Detached, townhouse	60 feet	None
Seismic bracing	SDC A – C	Detached		Use wind bracing
	SDC A – B	Townhouse		Use wind bracing
	SDC C	Townhouse	35 feet	Up to 50 feet when length of required bracing per Table R602.10.3(3) is adjusted in accordance with Table R602.10.3(4).
	SDC D ₀ , D ₁ , D ₂	Detached, townhouses, one- and two-story only	25 feet	Up to 35 feet to allow for a single room floor area, not to exceed 900 square feet of floor area enclosed by braced wall lines, where the spacing of all other braced wall lines does not exceed 25 feet. The required bracing per Table R602.10.3(3) is not required to be adjusted in accordance with Item 3 of Table R602.10.3(4) for this application. Spacing of all other braced wall lines shall not exceed 25 feet.
	SDC D ₀ , D ₁ , D ₂	Detached, townhouse	25 feet	Up to 35 feet when length of required bracing per Table R602.10.3(3) is adjusted in accordance with Table R602.10.3(4).

For SI: 1 foot = 304.8 mm, 1 square foot = 0.0929 m², 1 mile per hour = 0.447 m/s.

Section R602.10.2.2.1 – Model code change:

The model code added Exception no. 2 to clarify that hold-downs required by other sections of the code for ABWs, PFs and BV-WSPs meet the intent of this subsection without requiring an additional hold-down.

R602.10.2.2.1 Location of braced wall panels in Seismic Design Categories D₀, D₁ and D₂. Braced wall panels shall be located at each end of a *braced wall line*.

Exceptions:

1. Braced wall panels constructed of Method WSP, [PFH](#), [ABW](#) or BV-WSP and continuous sheathing methods as specified in Section R602.10.4 shall be permitted to begin not more than 10 feet (3048 mm) from each end of a *braced wall line* provided that each end complies with one of the following:
 - 1.1. A minimum 24-inch-wide (610 mm) panel for Methods WSP, CS-WSP, CS-G and CS-PF is applied to each side of the building corner as shown in End Condition 4 of Figure R602.10.7.
 - 1.2. The end of each *braced wall panel* closest to the end of the *braced wall line* shall have an 1,800-pound (8 kN) hold-down device fastened to the stud at the edge of the *braced wall panel* closest to the corner and to the foundation or framing below as shown in End Condition 5 of Figure R602.10.7.
 2. *Braced wall panels* constructed of Method PFH or ABW, or of Method BV-WSP where a hold-down is provided in accordance with Table R602.10.6.5.4, shall be permitted to begin not more than 10 feet (3048 mm) from each end of a *braced wall line*.
-

**TABLE R602.10.3(1)
BRACING REQUIREMENTS BASED ON WIND SPEED**

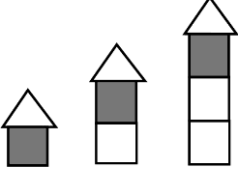
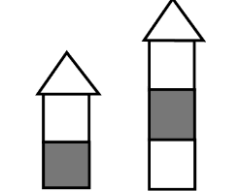
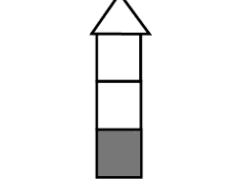
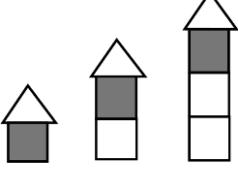
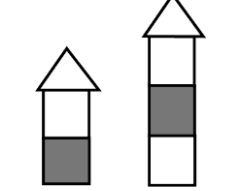
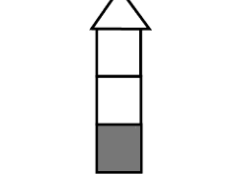
<ul style="list-style-type: none"> • EXPOSURE CATEGORY B • 30-FOOT MEAN ROOF HEIGHT • 10-FOOT WALL HEIGHT • 2 BRACED WALL LINES 		MINIMUM TOTAL LENGTH (FEET) OF BRACED WALL PANELS REQUIRED ALONG EACH BRACED WALL LINE ^a				
BASIC DESIGN WIND SPEED (mph)	Story Location	Braced Wall Line Spacing ^c (feet)	Method LIB ^b	Method GB	Methods DWB, WSP, SFB, PBS, PCP, HPS, BV-WSP, ABW, PFH, PFG, CS-SFB	Methods CS-WSP, CS-G, CS-PF
≤ 95 mph		10	2.5	2.5	1.5	1.5
		20	4.5	4.5	2.5	2.5
		30	6.5	6.5	4.0	3.5
		40	8.5	8.5	5.0	4.0
		50	10.5	10.5	6.0	5.0
		60	12.5	12.5	7.0	6.0
		10	5.0	5.0	3.0	2.5
		20	8.5	8.5	5.0	4.5
		30	12.5	12.5	7.0	6.0
		40	16.0	16.0	9.5	8.0
		50	20.0	20.0	11.5	10.0
		60	23.5	23.5	13.5	11.5
		10	NP	7.0	4.0	3.5
		20	NP	13.0	7.5	6.5
		30	NP	18.5	10.5	9.0
		40	NP	24.0	13.5	11.5
		50	NP	29.5	17.0	14.5
		60	NP	35.0	20.0	17.0
≤ 100		10	3.0	3.0	2.0	1.5
		20	5.5	5.5	3.0	3.0
		30	7.5	7.5	4.5	4.0
		40	10.0	10.0	6.0	5.0
		50	12.5	12.5	7.0	6.0
		60	14.5	14.5	8.5	7.0
		10	6.0	6.0	3.5	3.0
		20	10.0	10.0	6.0	5.0
		30	14.5	14.5	8.5	7.0
		40	18.5	18.5	11.0	9.5
		50	23.0	23.0	13.5	11.5
		60	27.5	27.5	15.5	13.5
		10	NP	8.5	5.0	4.0
		20	NP	15.0	9.0	7.5
		30	NP	21.5	12.5	10.5
		40	NP	28.0	16.0	13.5
		50	NP	34.0	19.5	16.5
		60	NP	40.5	23.0	20.0

(continued)

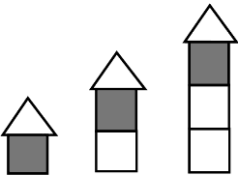
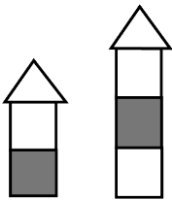
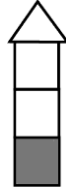
<u>≤ 105</u>		<u>10</u>	<u>3.5</u>	<u>3.5</u>	<u>2.0</u>	<u>1.5</u>
		<u>20</u>	<u>5.5</u>	<u>5.5</u>	<u>3.5</u>	<u>3.0</u>
		<u>30</u>	<u>8.0</u>	<u>8.0</u>	<u>5.0</u>	<u>4.5</u>
		<u>40</u>	<u>10.5</u>	<u>10.5</u>	<u>6.0</u>	<u>5.0</u>
		<u>50</u>	<u>13.0</u>	<u>13.0</u>	<u>7.5</u>	<u>6.5</u>
		<u>60</u>	<u>15.5</u>	<u>15.5</u>	<u>9.0</u>	<u>7.5</u>
		<u>10</u>	<u>6.0</u>	<u>6.0</u>	<u>3.5</u>	<u>3.0</u>
		<u>20</u>	<u>10.5</u>	<u>10.5</u>	<u>6.0</u>	<u>5.5</u>
		<u>30</u>	<u>15.5</u>	<u>15.5</u>	<u>9.0</u>	<u>7.5</u>
		<u>40</u>	<u>20.0</u>	<u>20.0</u>	<u>11.5</u>	<u>10.0</u>
		<u>50</u>	<u>24.5</u>	<u>24.5</u>	<u>14.5</u>	<u>12.0</u>
		<u>60</u>	<u>29.0</u>	<u>29.0</u>	<u>16.5</u>	<u>14.5</u>
		<u>10</u>	<u>NP</u>	<u>9.0</u>	<u>5.0</u>	<u>4.5</u>
		<u>20</u>	<u>NP</u>	<u>16.0</u>	<u>9.5</u>	<u>8.0</u>
		<u>30</u>	<u>NP</u>	<u>22.5</u>	<u>13.0</u>	<u>11.0</u>
		<u>40</u>	<u>NP</u>	<u>29.5</u>	<u>17.0</u>	<u>14.5</u>
		<u>50</u>	<u>NP</u>	<u>36.5</u>	<u>21.0</u>	<u>17.5</u>
		<u>60</u>	<u>NP</u>	<u>43.0</u>	<u>24.5</u>	<u>21.0</u>

[The rest of the table contents and footnotes remain unchanged]

**TABLE R602.10.3(2)
WIND ADJUSTMENT FACTORS TO THE REQUIRED LENGTH OF WALL BRACING**

ITEM NUMBER	ADJUSTMENT BASED ON	STORY/SUPPORTING	CONDITION	ADJUSTMENT FACTOR ^{a, b} [multiply length from Table R602.10.3(1) by this factor]	APPLICABLE METHODS
3	Story height (Section R301.3) Wall height	Any story	8 feet	0.90	All methods
			9 feet	0.95	
			10 feet	1.00	
			11 feet	1.05	
			12 feet	1.10	

[The rest of the table contents and footnotes remain unchanged]

Table R602.10.3(3) – Model code change

Three-story dwellings are now completely outside the scope of prescriptive seismic provisions in Seismic Design Category D₂.

**TABLE R602.10.3(3)
BRACING REQUIREMENTS BASED ON SEISMIC DESIGN CATEGORY**

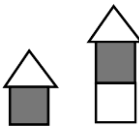
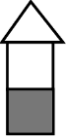
<ul style="list-style-type: none"> • WALL HEIGHT = 10 FEET • 10 PSF FLOOR DEAD LOAD • 15 PSF ROOF/CEILING DEAD LOAD • BRACED WALL LINE SPACING ≤ 25 FEET 		MINIMUM TOTAL LENGTH (FEET) OF BRACED WALL PANELS REQUIRED ALONG EACH BRACED WALL LINE ^{a, g}						
Seismic Design Category ^b	Story Location	Braced Wall Line Length (feet) ^c	Method LIB ^d	Method GB	Methods DWB, SFB, PBS, PCP, HPS, CS-SFB ^e	Methods WSP, ABW ^f , PFH ^f and PFG ^{e, f}	Methods CS-WSP, CS-G, CS-PF	
D ₂ ^h		10	NP	4.0	4.0	2.5	2.1	
		20	NP	8.0	8.0	5.0	4.3	
		30	NP	12.0	12.0	7.5	6.4	
		40	NP	16.0	16.0	10.0	8.5	
		50	NP	20.0	20.0	12.5	10.6	
		10	NP	7.5	7.5	5.5	4.7	
		20	NP	15.0	15.0	11.0	9.4	
		30	NP	22.5	22.5	16.5	14.0	
		40	NP	30.0	30.0	22.0	18.7	
		50	NP	37.5	37.5	27.5	23.4	
	Three-story dwelling	10	NP	NP	NP	NP	NP	NP
		20	NP	NP	NP	NP	NP	NP
		30	NP	NP	NP	NP	NP	NP
		40	NP	NP	NP	NP	NP	NP
		50	NP	NP	NP	NP	NP	NP
	Cripple wall below one- or two-story dwelling	10	NP	NP	NP	NP	7.5	6.4
		20	NP	NP	NP	NP	15.0	12.8
		30	NP	NP	NP	NP	22.5	19.1
		40	NP	NP	NP	NP	30.0	25.5
		50	NP	NP	NP	NP	37.5	31.9

[The rest of the table contents remain unchanged]

For SI: 1 inch = 25.4 mm, 1 foot = 304.8 mm, 1 pound per square foot = 0.0479 kPa. NP = Not Permitted.

- a. Linear interpolation shall be permitted.
- b. **Interpolation** of bracing length between the S_{ds} values associated with the seismic design categories shall be permitted when a site-specific S_{ds} value is determined in accordance with Section 1613.2 of the *Building Code*.
- c. Where the braced wall line length is greater than 50 feet, braced wall lines shall be permitted to be divided into shorter segments having lengths of 50 feet or less, and the amount of bracing within each segment shall be in accordance with this table.
- d. Method LIB shall have gypsum board fastened to not less than one side with nails or screws in accordance with Table R602.3(1) for exterior sheathing or Table R702.3.5 for interior gypsum board. Spacing of fasteners at panel edges shall not exceed 8 inches.
- e. Methods PFG and CS-SFB do not apply in Seismic Design Categories D₀, D₁ and D₂.
- f. **Methods PFH, PFG and ABW are only permitted on a single story or a first of two stories.**
- g. Where more than one bracing method is used, mixing methods shall be in accordance with Section R602.10.4.1.
- h. **One- and two-family dwellings in Seismic Design Category D₂ exceeding two stories shall be designed in accordance with [Section R301.1.3](#) ~~accepted engineering practice~~.**

TABLE R602.10.3(4)
SEISMIC ADJUSTMENT FACTORS TO THE REQUIRED LENGTH OF WALL BRACING

ITEM NUMBER	ADJUSTMENT BASED ON	STORY ^g	CONDITION	ADJUSTMENT FACTOR ^{a, b} [Multiply length from Table R602.10.3(3) by this factor]	APPLICABLE METHODS
1	Story height (Section 301.3) Wall height	Any story	≤ 10 feet	1.0	All methods
			> 10 feet and ≤ 12 feet	1.2	

[The rest of the table remains unchanged]

For SI: 1 foot = 304.8 mm, 1 pound per square foot = 0.0479 kPa.

- a. Linear interpolation shall be permitted.
- b. The total length of bracing required for a given wall line is the product of all applicable adjustment factors.
- c. The length-to-width ratio for the floor/roof diaphragm shall not exceed 3:1.
- d. Applies to stone or masonry veneer exceeding the first story height.
- e. The adjustment factor for stone or masonry veneer shall be applied to all exterior braced wall lines and all braced wall lines on the interior of the building, backing or perpendicular to and laterally supporting veneered walls.
- f. See Section R602.10.6.5 for requirements where stone or masonry veneer does not exceed the first-story height.
- g. One- and two-family dwellings in Seismic Design Category D₂ exceeding two stories shall be designed in accordance with Section R301.1.3-accepted-engineering-practice.

R602.10.4.1 Mixing methods. Mixing of bracing methods shall be permitted as follows:

1. Mixing intermittent bracing and continuous sheathing methods from story to story shall be permitted.
2. Mixing intermittent bracing methods from *braced wall line* to *braced wall line* within a story shall be permitted.
3. Mixing intermittent bracing and continuous sheathing methods from *braced wall line* to *braced wall line* within a story shall be permitted in regions within *Seismic Design Categories* A, B and C where the basic design wind speed is less than or equal to 130 mph (58m/s); ~~mixing of intermittent bracing and continuous sheathing methods from *braced wall line* to *braced wall line* within a story shall be permitted.~~
- 4.3. ~~Mixing intermittent bracing methods along a *braced wall line* shall be permitted in *Seismic Design Categories* A and B, and detached dwellings in *Seismic Design Category* C, provided that the length of required bracing in accordance with Table R602.10.3(1) or R602.10.3(3) is the highest value of all intermittent bracing methods used.~~
- 5.4. ~~Mixing of continuous sheathing methods CSWSP, CS-G and CS-PF along a *braced wall line* shall be permitted. Intermittent methods ABW, PFH and PFG shall be permitted to be used along a *braced wall line* with continuous sheathed methods, provided that the length of required bracing for that *braced wall line* is determined in accordance with Table R602.10.3(1) or R602.10.3(3) using the highest value of the bracing methods used.~~
- 6.5. ~~In *Seismic Design Categories* A and B, and for detached one- and two-family dwellings in *Seismic Design Category* C, mixing of intermittent bracing methods along the interior portion of a *braced wall line* with continuous sheathing methods CS-WSP, CS-G and CS-PF along the exterior portion of the same *braced wall line* shall be permitted. The length of required bracing shall be the highest value of all intermittent bracing methods used in accordance with Table R602.10.3(1) or R602.10.3(3) as adjusted by Tables R602.10.3(2) and R602.10.3(4), respectively. The requirements of Section R602.10.7 shall apply to each end of the continuously sheathed portion of the *braced wall line*.~~

**TABLE R602.10.5
MINIMUM LENGTH OF BRACED WALL PANELS**

METHOD (See Table R602.10.4)		MINIMUM LENGTH ^a (inches)					CONTRIBUTING LENGTH (inches)
		Wall Height					
		8 feet	9 feet	10 feet	11 feet	12 feet	
DWB, WSP, SFB, PBS, PCP, HPS, BV-WSP		48	48	48	53	58	Actual ^b
GB		48	48	48	53	58	Double sided = Actual Single sided = 0.5 × Actual
LIB		55	62	69	NP	NP	Actual ^b
ABW	SDC A, B and C, <u>basic</u> design wind speed < 140 mph	28	32	34	38	42	48
	SDC D0, D1 and D2, <u>basic</u> design wind speed < 140 mph	32	32	34	NP	NP	
CS-G		24	27	30	33	36	Actual ^b
CS-WSP, CS-SFB	Adjacent clear opening height (inches)						Actual ^b
	≤ 64	24	27	30	33	36	
	68	26	27	30	33	36	
	72	27	27	30	33	36	
	76	30	29	30	33	36	
	80	32	30	30	33	36	
	84	35	32	32	33	36	
	88	38	35	33	33	36	
	92	43	37	35	35	36	
	96	48	41	38	36	36	
	100	—	44	40	38	38	
	104	—	49	43	40	39	
	108	—	54	46	43	41	
	112	—	—	50	45	43	
	116	—	—	55	48	45	
	120	—	—	60	52	48	
	124	—	—	—	56	51	
	128	—	—	—	61	54	
132	—	—	—	66	58		
136	—	—	—	—	62		
140	—	—	—	—	66		
144	—	—	—	—	72		
METHOD (See Table R602.10.4)		Portal header height					
		8 feet	9 feet	10 feet	11 feet	12 feet	
PFH	Supporting roof only	16	16	16	Note e	Note e	48
	Supporting one story and roof	24	24	24	Note e	Note e	
PFG		24	27	30	Note d	Note d	1.5 × Actual ^b
CS-PF	SDC A, B and C	16	18	20	Note e	Note e	1.5 × Actual ^b
	SDC D0, D1 and D2	16	18	20	Note e	Note e	Actual ^b

For SI: 1 inch = 25.4 mm, 1 foot = 304.8 mm, 1 mile per hour = 0.447 m/s. NP = Not Permitted.

a. Linear interpolation shall be permitted.

b. Use the actual length where it is greater than or equal to the minimum length.

~~e. Maximum header height for PFH is 10 feet in accordance with Figure R602.10.6.2, but wall height shall be permitted to be increased to 12 feet with pony wall.~~

~~d. Maximum header height for PFG is 10 feet in accordance with Figure R602.10.6.3, but wall height shall be permitted to be increased to 12 feet with pony wall.~~

~~e. Maximum header height for CS-PF is 10 feet in accordance with Figure R602.10.6.4, but wall height shall be permitted to be increased to 12 feet with pony wall.~~

FIGURE R602.10.6.2
METHOD PFH—PORTAL FRAME WITH HOLD-DOWNS

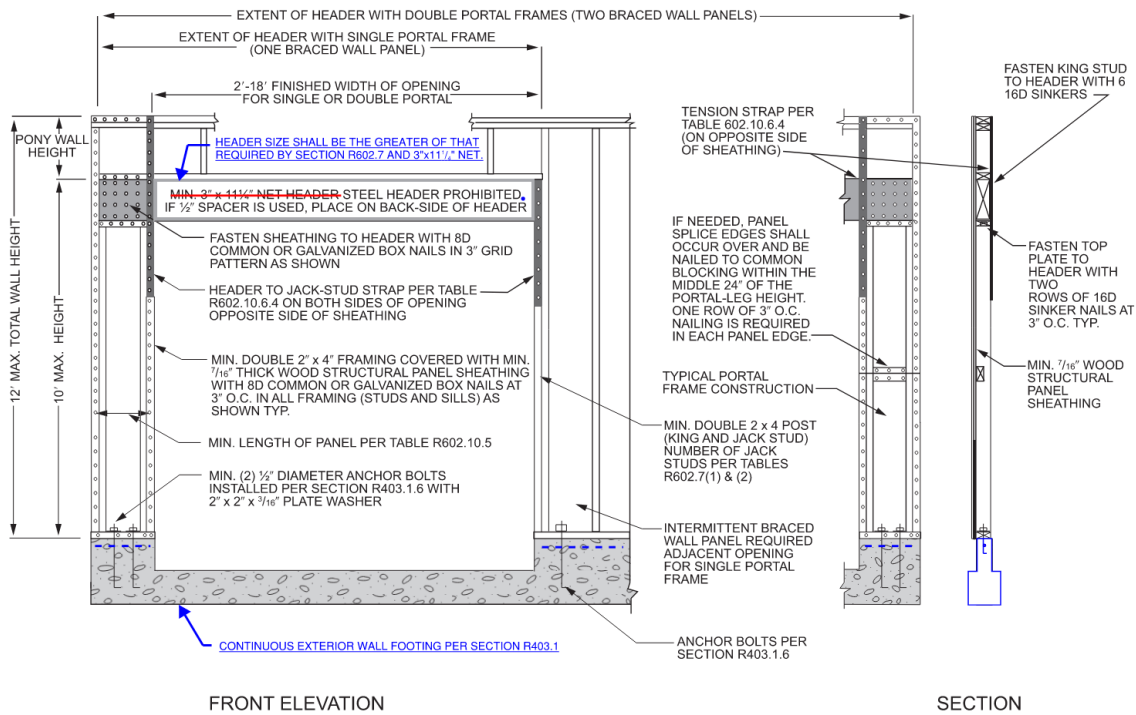

FIGURE R602.10.6.3
METHOD PFG—PORTAL FRAME AT GARAGE DOOR OPENINGS IN SEISMIC DESIGN CATEGORIES A, B AND C

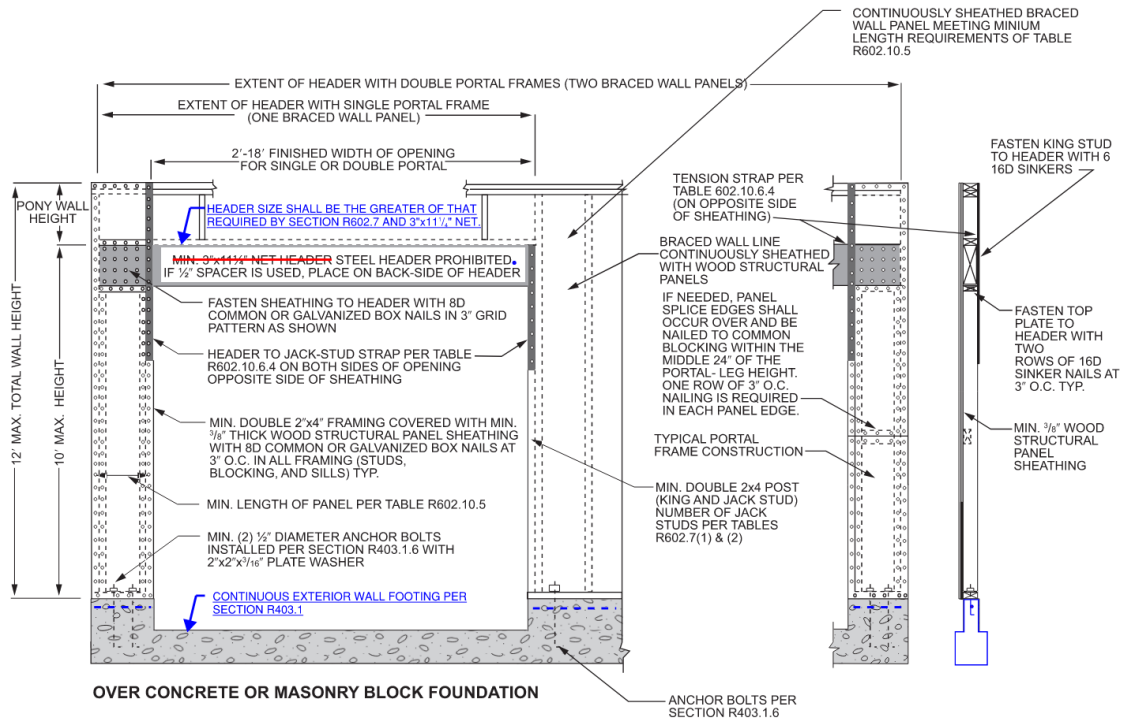

FIGURE R602.10.6.4
METHOD CS-PF—CONTINUOUSLY SHEATHED PORTAL FRAME PANEL CONSTRUCTION

Section R602.10.6.5 – Model code change

R602.10.6.5 Wall bracing for dwellings with stone and masonry veneer in Seismic Design Categories D₀, D₁ and D₂. Townhouses in *Seismic Design Categories* D₀, D₁ and D₂ with stone or masonry veneer exceeding the first-story height shall be designed in accordance with [Section R301.1.3](#) ~~accepted engineering practice~~.

One- and two-family dwellings in *Seismic Design Category* D₂ exceeding two stories and having stone or masonry veneer shall be designed in accordance with [Section R301.1.3](#) ~~accepted engineering practice~~.

Where stone and masonry veneer are installed in accordance with Section R703.8, wall bracing on exterior *braced wall lines* and *braced wall lines* on the interior of the building, backing or perpendicular to and laterally supporting veneered walls shall comply with this section.

R602.10.6.5.1 Veneer on first story only. Where dwellings in *Seismic Design Categories* D₀, D₁ and D₂ have stone or masonry veneer installed in accordance with Section R703.8 and the veneer does not exceed the first-story height, wall bracing shall be in accordance with Section R602.10, exclusive of Section R602.10.6.5.

R602.10.6.5.2 Veneer exceeding first-story height. Where detached one- or two-family dwellings in *Seismic Design Categories* D₀, D₁ and D₂ have stone or masonry veneer installed in accordance with Section R703.8, and the veneer exceeds the first-story height, wall bracing at exterior *braced wall lines* and *braced wall lines* on the interior of the building shall be constructed using Method BV-WSP in accordance with this section and Figure R602.10.6.5.2. Cripple walls shall not be permitted, and required interior *braced wall lines* shall be supported on continuous foundations.

R602.10.6.5.3 Limited veneer exceeding first-story height. Where detached one- or two-family dwellings in *Seismic Design Categories* D₀, D₁ and D₂ have exterior veneer installed in accordance with Section R703.8 and where brick veneer installed above the first-story height meets the following limitations, bracing in accordance with Method WSP or CS-WSP shall be permitted provided that the total length of *braced wall panels* specified by Table R602.10.3(3) is multiplied by 1.2 for each first- and second-story *braced wall line*.

1. The dwelling does not extend more than two stories above *grade plane*.
2. The veneer does not exceed 5 inches (127 mm) in thickness.
3. The height of veneer on gable-end walls does not extend more than 8 feet (2438 mm) above the bearing wall top plate elevation.
4. Where veneer is installed on multiple walls above the first story, the total area of the veneer on the second-story exterior walls shall not exceed 25 percent of the occupied second floor area.
5. Where the veneer is installed on one entire second-story exterior wall, including walls on bay windows and similar appurtenances, brick veneer shall not be installed on any of the other walls on that floor.

**TABLE R602.10.6.5.4
METHOD BV-WSP WALL BRACING REQUIREMENTS^d**

[The table contents remain unchanged]

For SI: 1 inch = 25.4 mm, 1 foot = 304.8 mm, 1 pound per square foot = 0.479 kPa, 1 pound-force = 4.448 N. NP = Not Permitted.
NA = Not Applicable.

- a. One- and two-family dwellings in Seismic Design Category D_2 exceeding two stories shall be designed in accordance with [Section R301.1.3](#) ~~accepted engineering practice~~.
- b. Hold-down force is minimum allowable stress design load for connector providing uplift tie from wall framing at end of braced wall panel at the noted story to wall framing at end of braced wall panel at the story below, or to foundation or foundation wall. Use single-story hold-down force where edges of braced wall panels do not align; a continuous load path to the foundation shall be maintained.
- c. Where hold-down connectors from stories above align with stories below, use cumulative hold-down force to size middle- and bottom-story hold-down connectors.
- d. Interpolation between braced wall lengths is permitted.

Figure R602.10.7 – *Parts of the figure not shown here remain unchanged.*

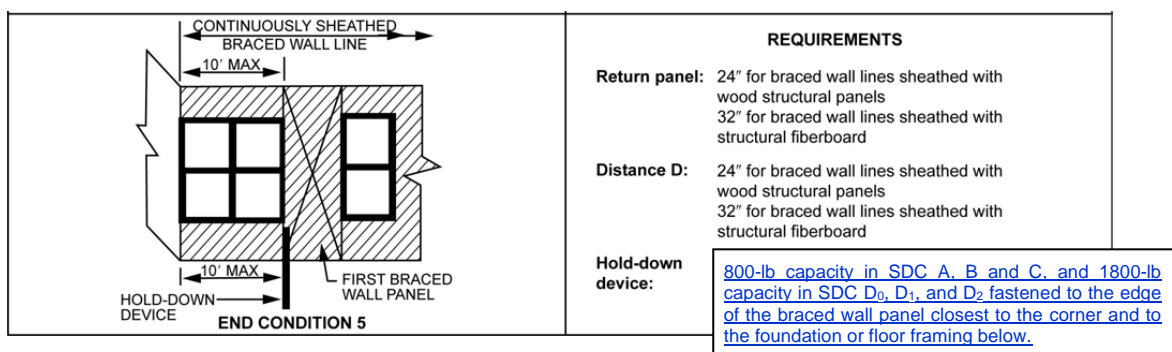

**FIGURE R602.10.7
END CONDITIONS FOR BRACED WALL LINES WITH CONTINUOUS SHEATHING**

R602.10.8.2 Connections to roof framing. Top plates of exterior *braced wall panels* shall be attached to rafters or roof trusses above in accordance with Table R602.3(1) and this section. Where required by this section, blocking between rafters or roof trusses shall be attached to top plates of *braced wall panels* and to rafters and roof trusses in accordance with Table R602.3(1). A continuous band, rim or header joist or roof truss parallel to the *braced wall panels* shall be permitted to replace the blocking required by this section. Blocking shall not be required over openings in continuously sheathed *braced wall lines*. In addition to the requirements of this section, lateral support shall be provided for rafters and ceiling joists in accordance with Section R802.8 and for trusses in accordance with Section R802.10.3. Roof *ventilation* shall be provided in accordance with Section R806.1.

[1 through 3.3 remain unchanged.]

3.4. Blocking, blocking panels or other methods of lateral load transfer designed in accordance with the AWC WFCM or [Section R301.1.3](#) ~~accepted engineering practice~~.

R602.10.9 Braced wall panel support. *Braced wall panel* support shall be provided as follows:

[1, 3 and 4 remain unchanged]

2. Raised floor system post or pier foundations supporting *braced wall panels* shall be designed in accordance with [Section R301.1.3](#) ~~accepted engineering practice~~.

R602.10.10.1 Cripple wall bracing for Seismic Design Categories D_0 and D_1 and townhouses in Seismic Design Category C. In addition to the requirements in Section R602.10.10, *cripple wall bracing shall be limited to methods WSP and CS-WSP*, and the distance between adjacent edges of *braced wall panels* for cripple walls along a *braced wall line* shall be 14 feet (4267 mm) maximum.

Where *braced wall lines* at interior walls are not supported on a continuous foundation below, the adjacent parallel cripple walls, where provided, shall be braced with Method WSP or Method CS-WSP in accordance with Section R602.10.4. The length of bracing required in accordance with Table R602.10.3(3) for the cripple walls shall be multiplied by 1.5. Where the cripple walls do not have sufficient length to provide the required bracing, the spacing of panel edge fasteners shall be reduced to 4 inches (102 mm) on center and the required bracing length adjusted by 0.7. If the required length can still not be provided, the cripple wall shall be designed in accordance with [Section R301.1.3](#) ~~accepted engineering practice~~.

SECTION R606 GENERAL MASONRY CONSTRUCTION

IRC R606.1.1 Professional registration not required. *...Not adopted.*

SECTION R608 EXTERIOR CONCRETE WALL CONSTRUCTION

R608.1 General. Exterior concrete walls shall be designed and constructed in accordance with the provisions of this section or in accordance with the provisions of PCA 100, ACI 318 or ACI 332. ~~Where PCA 100, ACI 318, ACI 332 or the provisions of this section are used to design concrete walls, project drawings, typical details and specifications are not required to bear the seal of the architect or engineer responsible for design, unless otherwise required by the state law of the jurisdiction having authority.~~

R608.9.2 Connections between concrete walls and light-frame floor systems. Connections between concrete walls and light-frame floor systems shall be in accordance with one of the following:

[Items 1 through 3 remain unchanged.]

4. ~~An engineered~~ *nonprescriptive design* using loads and load combinations in accordance with Appendix A (ASD) or Appendix B (LRFD) of PCA 100.
5. ~~An engineered~~ *nonprescriptive design* using loads and material design provisions in accordance with this code, or in accordance with ASCE 7, ACI 318, and AWC NDS for wood-framed construction or AISI S100 for cold-formed steel frame construction.

R608.9.3 Connections between concrete walls and light-frame ceiling and roof systems. Connections between concrete walls and light-frame ceiling and roof systems shall be in accordance with one of the following:

[Items 1 through 3 remain unchanged.]

4. ~~An engineered~~ *nonprescriptive design* using loads and load combinations in accordance with Appendix A (ASD) or Appendix B (LRFD) of PCA 100.
5. ~~An engineered~~ *nonprescriptive design* using loads and material design provisions in accordance with this code, or in accordance with ASCE 7, ACI 318, and AWC NDS for wood-framed construction or AISI S100 for cold-formed steel-framed construction.

SECTION R609 EXTERIOR WINDOWS AND DOORS

R609.1 General. This section prescribes performance and construction requirements for exterior windows and sliding doors installed in walls. Windows and sliding doors shall be installed in accordance with the fenestration manufacturer's written instructions. Window and door openings shall be flashed in accordance with Section R703.4. ~~Written installation instructions shall be provided by the fenestration manufacturer for each window or door.~~

R609.2 Performance. Not adopted by the State of Oregon, Building Codes Division, as part of this code.

[The rest of this section is deleted]

R609.3 Testing and labeling. Exterior windows and sliding doors shall be tested by an *approved* independent laboratory, and bear a *label* identifying manufacturer, performance characteristics and *approved* inspection agency to indicate compliance with AAMA/WDMA/CSA 101/I.S.2/A440. Exterior side-hinged doors shall ~~be tested and labeled as conforming to AAMA/WDMA/CSA 101/I.S.2/A440 or AMD 100, or~~ comply with Section R609.5.

Exception: Decorative glazed openings.

R609.3.1 Comparative analysis. Structural wind load design pressures for window and door units different than the size tested in accordance with Section R609.3 shall be permitted to be different than the design value of the tested unit where determined in accordance with one of the following comparative analysis methods:

1. Structural wind load design pressures for window and door units smaller than the size tested in accordance with Section R609.3 shall be permitted to be higher than the design value of the tested unit provided such higher pressures are determined by accepted approved engineering analysis. Components of the smaller unit shall be the same as those of the tested unit. Where such calculated design pressures are used, they shall be validated by an additional test of the window or door unit having the highest allowable design pressure.
2. In accordance with WDMA I.S.11.

R609.4 Garage doors. ~~Not adopted by the State of Oregon, Building Codes Division, as part of this code. Garage doors shall be tested in accordance with either ASTM E330 or ANSI/DASMA 108, and shall meet the pass/fail criteria of ANSI/DASMA 108.~~

IRC R609.4.1 Garage door labeling. ~~...Not adopted.~~

R609.5 Other exterior window and door assemblies. Exterior windows and door assemblies not included within the scope of Section R609.3 ~~or R609.4~~ shall be tested in accordance with ASTM E330. Glass in assemblies covered by this section shall comply with Section R308.5.

R609.6 Windborne debris protection. ~~Not adopted by the State of Oregon, Building Codes Division, as part of this code. Protection of exterior windows, glass doors and doors with glass in buildings located in windborne debris regions shall be in accordance with Section R301.2.1.2.~~

IRC R609.6.1 Fenestration testing and labeling. ~~...Not adopted.~~

IRC R609.6.2 Impact protective systems testing and labeling. ~~...Not adopted.~~

R609.7.1 Anchoring requirements. Window and glass door assemblies shall be anchored in accordance with the published manufacturer's recommendations to achieve the design pressure specified. Substitute anchoring systems used for substrates not specified by the fenestration manufacturer shall provide equal or greater anchoring performance as demonstrated by a design in accordance with Section R301.1.3 ~~accepted engineering practice~~.

R609.8 Mullions. Mullions shall be tested by an *approved* testing laboratory in accordance with AAMA 450, or be designed in accordance with Section R301.1.3 ~~engineered in accordance with accepted engineering practice~~. Mullions tested as stand-alone units or qualified by nonprescriptive design engineering shall use performance criteria cited in Sections R609.8.1, R609.8.2 and R609.8.3. Mullions qualified by an actual test of an entire assembly shall comply with Sections R609.8.1 and R609.8.3.

CHAPTER 7

WALL COVERING

SECTION R702 INTERIOR COVERING

All of IRC R702.7 is not adopted and is deleted.

SECTION R703 EXTERIOR COVERING

IRC R703.1.1 Water resistance. ...*Not adopted.*

R703.1.1 Exterior wall envelope. The exterior wall envelope shall be installed in a manner such that water entering the assembly can drain to the exterior. The envelope shall consist of an exterior veneer and a water-resistant barrier, as required by Section R703.2, a space not less than 1/8 inch (3 mm) between the water-resistive barrier and the exterior veneer, and integrated flashings, as required by Section R703.4. The required space shall be formed by the use of any noncorrosive furring strip, drainage mat or drainage board. The envelope shall provide proper integration of flashings with the water-resistive barrier, the drainage space provided and the exterior veneer or wall covering. These components combined shall provide a means of draining water entering the assembly to the exterior.

Exceptions:

1. A space is not required where the exterior wall covering is installed over a water-resistive barrier complying with Section R703.2 that is manufactured in a manner to enhance drainage and meets the 75-percent drainage efficiency requirement of ASTM E2273 or other recognized national standard.
2. A space is not required where windowsills are equipped with pan flashings that drain to the exterior surface of the wall covering in a through-wall fashion. All pan flashings shall be detailed within the construction documents and shall be of either a self-adhering membrane complying with AAMA 711 or of an approved corrosion-resistant material or a combination thereof. Self-adhering membranes extending to the exterior surface of the wall covering shall be concealed with trims or other measures to protect from sunlight.
3. A space is not required for detached accessory structures.
4. A space is not required for additions, alterations or repairs where the new exterior wall covering is all of the following:
 - 4.1. Matching the existing exterior wall covering.

4.2. Installed in the same plane as the existing wall covering without a change in direction or use of a control joint.

4.3. Installed over a water-resistive barrier complying with Section R703.2.

5. ~~A weather resistant exterior wall envelope~~ The requirements of Section R703.1.1 shall not be required over concrete or masonry walls designed in accordance with Chapter 6 and flashed in accordance with Section R703.4 or R703.8.

6. Compliance with the requirements for a means of drainage, and the requirements of Sections R703.2 and R703.4, shall not be required for an exterior wall envelope that has been demonstrated to resist wind-driven rain through testing of the exterior wall envelope assembly, including joints, trim, exterior covering, penetrations, window and door openings and intersections with dissimilar materials, in accordance with ASTM E331 under the following conditions:

6.1. Exterior wall envelope test assemblies shall include at least one opening, one control joint, one wall/eave interface and one wall sill. All tested openings and penetrations shall be representative of the intended end-use configuration.

6.2. Exterior wall envelope test assemblies shall be at least 4 feet by 8 feet (1219 mm by 2438 mm) in size.

6.3. Exterior wall assemblies shall be tested at a minimum differential pressure of 6.24 pounds per square foot (299 Pa).

6.4. Exterior wall envelope assemblies shall be subjected to the minimum test exposure for a minimum of 2 hours.

The exterior wall envelope design shall be considered to resist wind-driven rain where the results of testing indicate that water did not penetrate control joints in the exterior wall envelope, joints at the perimeter of openings penetration or intersections of terminations with dissimilar materials.

R703.1.2 Wind resistance. Wall coverings, backing materials and their attachments shall be capable of resisting wind loads in accordance with Tables R301.2.1(1) and R301.2.1(2). Wind-pressure resistance of the siding, soffit and backing materials shall be determined by ASTM E330 or other applicable standard test methods. Where wind-pressure resistance is determined by design analysis, data from *approved* design standards and analysis ~~conforming to generally accepted engineering practice~~ shall be used to evaluate the siding, soffit and backing material and its fastening. All applicable failure modes including bending rupture of siding, fastener withdrawal and fastener head pull-through shall be considered in the testing or design analysis. Where the wall covering, soffit and backing material resist wind load as an assembly, use of the design capacity of the assembly shall be permitted.

Section R703.2 – Model code changes:

Language for water-resistive barriers is clarified. Additional compliance options have been added, along with retaining reference of ASTM E2273 to correlate with R703.1 and the drainage plane.

R703.2 Water-resistive barrier. Not fewer than one layer of *water-resistive barrier* shall be applied over studs or sheathing of all exterior walls with flashing as indicated in Section R703.4, in such a manner as to provide a continuous water-resistive barrier behind the exterior wall veneer. The water-resistive barrier material shall be continuous to the top of walls and terminated at penetrations and building appendages in a manner to meet the requirements of the exterior wall envelope as described in Section R703.1. Water-resistive barrier materials shall comply with one of the following:

1. No. 15 felt complying with ASTM D226, Type 1.
2. ASTM 2556, Type 1 or 2.
3. ASTM E331 ~~in accordance with Section R703.1.1.~~
4. [ASTM E2273](#).
5. ~~4.~~ Other approved materials in accordance with the *manufacturer's installation instructions*.

No.15 asphalt felt and *water-resistive barriers* complying with ASTM E2556 shall be applied horizontally, with the upper layer lapped over the lower layer not less than 2 inches (51 mm), and where joints occur, shall be lapped not less than 6 inches (152 mm).

R703.4 Flashing. *Approved* corrosion-resistant flashing shall be applied *shingle-fashion* in a manner to prevent entry of water into the wall cavity or penetration of water to the building structural framing components. Self-adhered membranes used as flashing shall comply with AAMA 711. Fluid-applied membranes used as flashing in exterior walls shall comply with AAMA 714. The flashing shall extend to the surface of the exterior wall finish. *Approved* corrosion-resistant flashings shall be installed at the following locations:

1. Exterior window and door openings. Flashing at exterior window and door openings shall **be installed in accordance with Section R703.4.1.**
2. At the intersection of chimneys or other masonry construction with frame or stucco walls, with projecting lips on both sides under stucco copings.
3. Under and at the ends of masonry, wood or metal copings and sills.
4. Continuously above all projecting wood *trim*.
5. Where exterior porches, decks or stairs attach to a wall or floor assembly of wood-frame construction.
6. At wall and roof intersections. [Kick-out flashings shall be installed at all wall and roof intersections, such as where a lower roofline terminates against a vertical wall \(see Figure R703.4\).](#)
7. At built-in gutters.

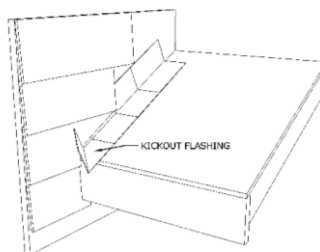

FIGURE R703.4
KICK-OUT FLASHING

R703.4.1 Flashing installation at exterior window and door openings. Flashing at exterior window and door openings shall extend to the surface of the exterior wall finish or to a *water-resistive barrier* complying with Section 703.2 for subsequent drainage. Air sealing shall be installed around all window and door openings on the interior side of the rough opening gap. Mechanically attached flexible flashings shall comply with AAMA 712. Flashing at exterior window and door openings shall be installed in accordance with one or more of the following:

1. The fenestration manufacturer's installation and flashing instructions, or for applications not addressed in the fenestration manufacturer's instructions, in accordance with the flashing manufacturer's instructions. Where flashing instructions or details are not provided, *pan flashing* shall be installed at the sill of exterior window and door openings. *Pan flashing* shall be sealed or sloped in such a manner as to direct water to the surface of the exterior wall finish or to the water-resistive barrier for subsequent drainage. Openings using *pan flashing* shall incorporate flashing or protection at the head and sides.
- ~~2. In accordance with the flashing design or method of a registered design professional.~~
- ~~2.3~~ 2. In accordance with other *approved methods*.

R703.5 Wood, hardboard and wood structural panel siding. Wood, hardboard and wood structural panel siding shall be installed in accordance with this section and Table R703.3(1). Hardboard siding shall comply with ANSI A135.5.

~~R703.5.1 Vertical wood siding.~~

~~**R703.5.2 Panel siding.** Three eighths inch (9.5 mm) wood structural panel siding shall not be applied directly to studs spaced more than 16 inches (406 mm) on center where long dimension is parallel to studs. Wood structural panel siding $\frac{7}{16}$ inch (11.1 mm) or thinner shall not be applied directly to studs spaced more than 24 inches (610 mm) on center. The stud spacing shall not exceed the panel span rating provided by the manufacturer unless the panels are installed with the face grain perpendicular to the studs or over sheathing *approved* for that stud spacing.~~

R703.5.1 Panel siding. Joints in wood, hardboard or wood structural panel siding shall be made as follows unless otherwise *approved*. Vertical joints in panel siding shall occur over framing members, unless wood or wood structural panel sheathing is used, and shall be shiplapped or covered with a batten. Horizontal joints in panel siding shall be lapped not less than 1 inch (25 mm) or shall be shiplapped or flashed with Z-flashing and occur over solid blocking, wood or wood structural panel sheathing.

R703.5.2 ~~R703.5.3~~ Horizontal wood siding. Horizontal lap siding shall be installed in accordance with the manufacturer's recommendations. Where there are no recommendations, the siding shall be lapped not less than 1 inch (25 mm), or $\frac{1}{2}$ inch (12.7 mm) if rabbeted, and shall have the ends caulked, covered with a batten or sealed and installed over a strip of flashing.

R703.7.3.1 Application over wood sheathing. ~~Dry climates. In Dry (B) climate zones indicated in Figure N1101.7, *Water-resistive barriers* applied over wood-based sheathing shall comply with one of the following:~~

1. The *water-resistive barrier* shall be two layers of 10-minute Grade D paper or have a water resistance equal to or greater than two layers of a *water-resistive barrier* complying with ASTM E2556, Type I. The individual layers shall be installed independently such that each layer provides a separate continuous plane. Flashing installed in accordance with Section R703.4 and intended to drain to the *water-resistive barrier* shall be directed between the layers.
2. The *water-resistive barrier* shall be 60-minute Grade D paper or have a water resistance equal to or greater than one layer of a *water-resistive barrier* complying with ASTM E2556, Type II. The *water-resistive barrier* shall be separated from the stucco by a layer of foam plastic *insulating sheathing* or other non-water-absorbing layer, or a designed drainage space.

R703.7.3.1.1 ~~R703.7.3.2~~ Moist or marine climates. In Benton, Clackamas, Clatsop, Columbia, Coos, Curry, Douglas, Jackson, Josephine, Lane, Lincoln, Linn, Marion, Multnomah, Polk, Tillamook, Washington and Yamhill counties, ~~Moist (A) or Marine (C) climate zones indicated in Figure N1101.7, *water-resistive barriers* applied over wood-based sheathing shall comply with one of the following:~~

1. In addition to complying with Section R703.7.3.1, a space or drainage material not less than $\frac{3}{16}$ inch (5 mm) in depth shall be added to the exterior side of the *water-resistive barrier*.
2. In addition to complying with Section R703.7.3.1, Item 2, drainage on the exterior of the *water-resistive barrier* shall have a drainage efficiency of not less than 90 percent, as measured in accordance with ASTM E2273 or Annex A2 of ASTM E2925.

R703.9 Exterior insulation and finish system (EIFS) ~~EIFS~~ with drainage. Exterior insulation and finish systems (EIFS) ~~shall comply with this chapter and Section R703.9.1. EIFS~~ with drainage shall comply with this chapter and Section [R703.9.1](#) ~~R703.9.2~~.

R703.9.1 Exterior insulation and finish systems (EIFS).

R703.9.1 R703.9.2 Exterior insulation and finish system (EIFS) with drainage. EIFS with drainage shall comply with the following:

[1 through 9 remains unchanged.]

ORS 701.555 prohibits Construction Contractors Board licensees from installing barrier-type exterior insulation and finish systems.

ORS 701.555 is not part of this code but is reprinted here for the reader's convenience:

701.555 Rulings on acceptability of material, design or installation of EIFS.

(1) As used in this section, "barrier-type exterior insulation and finish system" means a foam insulation board inner layer, a polymer and cement base coat middle layer reinforced with glass fiber mesh and a textured finish coat exterior layer, in which:

- (a) The layers are bonded to the outside face of an exterior wall;
- (b) The middle or exterior layer, but not the inner layer, provides a water-resistant barrier for the exterior of the building envelope;
- (c) The layers do not provide a means of drainage for water that accumulates behind the exterior surface; and
- (d) The layers insulate the building.

(2) A person licensed or required to be licensed under this chapter may not install a barrier-type exterior insulation and finish system on:

- (a) A new building; or
- (b) An existing building, except as necessary to repair or replace a previously installed barrier-type exterior insulation and finish system.

(3) Subsection (2) of this section does not apply to the application of a barrier-type exterior insulation and finish system:

- (a) As an architectural feature that is not intended to protect an interior space of the building; or
- (b) To a concrete wall or a concrete masonry unit block wall.

SECTION R704 SOFFITS

Section R704 – Model code changes:

Additional requirements for soffit material and installation have been added to Chapter 7, organized based on site design wind pressure. New Section R704 details these provisions.

R704.1 General wind limitations. Where the design wind pressure is 30 pounds per square foot (1.44 kPa) or less, soffits shall comply with Section R704.2. Where the design wind pressure exceeds 30 pounds per square foot (1.44 kPa), soffits shall comply with Section R704.3. The design wind pressure on soffits shall be determined using the component and cladding loads specified in Table R301.2.1(1) for walls using an effective wind area of 10 square feet (0.93 m²) and adjusted for height and exposure in accordance with Table R301.2.1(2).

R704.2 Soffit installation where the design wind pressure is 30 psf or less. Where the design wind pressure is 30 pounds per square foot (1.44 kPa) or less, soffit installation shall comply with Section R704.2.1, R704.2.2, R704.2.3 or R704.2.4. Soffit materials not addressed in Sections R704.2.1 through R704.2.4 shall be in accordance with the manufacturer's installation instructions.

R704.2.1 Vinyl soffit panels. Vinyl soffit panels shall be installed using fasteners specified by the manufacturer and shall be fastened at both ends to a supporting component such as a nailing strip, fascia or subfascia component in accordance with Figure R704.2.1(1). Where the unsupported span of soffit panels is greater than 16 inches (406 mm), intermediate nailing strips shall be provided in accordance with Figure

R704.2.1(2). Vinyl soffit panels shall be installed in accordance with the manufacturer's installation instructions. Fascia covers shall be installed in accordance with the manufacturer's installation instructions.

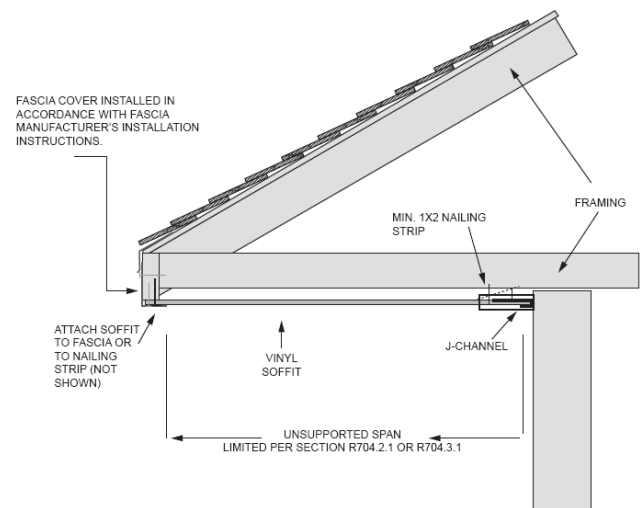

**FIGURE R704.2.1(1)
TYPICAL SINGLE-SPAN VINYL SOFFIT PANEL SUPPORT**

R704.2.2 Fiber-cement soffit panels. Fiber-cement soffit panels shall be a minimum of $\frac{1}{4}$ inch (6.4 mm) in thickness and shall comply with the requirements of ASTM C1186, Type A, minimum Grade II, or ISO 8336, Category A, minimum Class 2. Panel joints shall occur over framing or over wood structural panel sheathing. Soffit panels shall be installed with spans and fasteners in accordance with the manufacturer’s installation instructions.

R704.2.3 Hardboard soffit panels. Hardboard soffit panels shall be not less than $\frac{7}{16}$ inch (11.11 mm) in thickness and shall be fastened to framing or nailing strips with $2\frac{1}{2}$ -inch by 0.113-inch (64 mm by 2.9 mm) siding nails spaced not more than 6 inches (152 mm) on center at panel edges and 12 inches (305 mm) on center at intermediate supports.

R704.2.4 Wood structural panel soffit. The minimum nominal thickness for wood structural panel soffits shall be $\frac{3}{8}$ inch (9.5 mm) and shall be fastened to framing or nailing strips with 2-inch by 0.099-inch (51 mm by 2.5 mm) nails. Fasteners shall be spaced not less than 6 inches (152 mm) on center at panel edges and 12 inches (305 mm) on center at intermediate supports.

R704.3 Soffit installation where the design wind pressure exceeds 30 psf. Where the design wind pressure is greater than 30 psf, soffit installation shall comply with Section R704.3.1, R704.3.2, R704.3.3 or R704.3.4. Soffit materials not addressed in Sections R704.3.1 through R704.3.4 shall be in accordance with the manufacturer’s installation instructions.

R704.3.1 Vinyl soffit panels. Vinyl soffit panels and their attachments shall be capable of resisting wind loads specified in Table R301.2.1(1) for walls using an effective wind area of 10 square feet (0.929 m²) and adjusted for height and exposure in accordance with Table R301.2.1(2). Vinyl soffit panels shall be installed using fasteners specified by the manufacturer and shall be fastened at both ends to a supporting component such as a nailing strip, fascia or subfascia component in accordance with Figure R704.2.1(1). Where the unsupported span of soffit panels is greater than 12 inches (305 mm), intermediate nailing strips shall be provided in accordance with Figure R704.2.1(2). Vinyl soffit panels shall be installed in accordance with the manufacturer’s installation instructions. Fascia covers shall be installed in accordance with the manufacturer’s installation instructions.

R704.3.2 Fiber-cement soffit panels. Fiber-cement soffit panels shall comply with Section R704.2.2 and shall be capable of resisting wind loads specified in Table R301.2.1(1) for walls using an effective wind area of 10 square feet (0.929 m²) and adjusted for height and exposure in accordance with Table R301.2.1(2).

R704.3.3 Hardboard soffit panels. Hardboard soffit panels shall comply with the manufacturer’s installation instructions and shall be capable of resisting wind loads specified in Table R301.2.1(1) for walls using an effective wind area of 10 square feet (0.929 m²) and adjusted for height and exposure in accordance with Table R301.2.1(2).

R704.3.4 Wood structural panel soffit. Wood structural panel soffits shall be capable of resisting wind loads specified in Table R301.2.1(1) for walls using an effective wind area of 10 square feet (0.929 m²) and adjusted for height and exposure in accordance with Table R301.2.1(2). Alternatively, wood structural panel soffits shall be installed in accordance with Table R704.3.4.

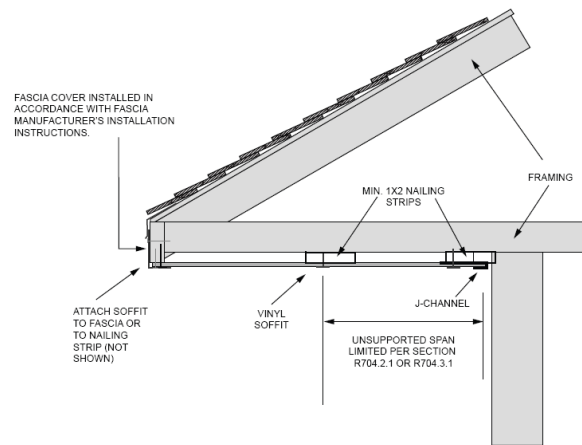

**FIGURE R704.2.1(2)
TYPICAL DOUBLE-SPAN VINYL SOFFIT PANEL SUPPORT**

TABLE R704.3.4
PRESCRIPTIVE ALTERNATIVE FOR WOOD STRUCTURAL PANEL SOFFIT ^{b, c, d, e}

MAXIMUM DESIGN PRESSURE (+ or psf)	MINIMUM PANEL SPAN RATING	MINIMUM PANEL PERFORMANCE CATEGORY	NAIL TYPE AND SIZE	FASTENER ^a SPACING ALONG EDGES AND INTERMEDIATE SUPPORTS	
				Galvanized Steel	Stainless Steel
30	24/0	3/8	6d box (2 × 0.099 × 0.266 head diameter)	6f	4
40	24/0	3/8	6d box (2 × 0.099 × 0.266 head diameter)	6	4
50	24/0	3/8	6d box (2 × 0.099 × 0.266 head diameter)	4	4
			8d common (2½ × 0.131 × 0.281 head diameter)	6	6
60	24/0	3/8	6d box (2 × 0.099 × 0.266 head diameter)	4	3
			8d common (2½ × 0.131 × 0.281 head diameter)	6	4
70	24/16	7/16	8d common (2½ × 0.131 × 0.281 head diameter)	4	4
			10d box (3 × 0.128 × 0.312 head diameter)	6	4
80	24/16	7/16	8d common (2½ × 0.131 × 0.281 head diameter)	4	4
			10d box (3 × 0.128 × 0.312 head diameter)	6	4
90	32/16	15/32	8d common (2½ × 0.131 × 0.281 head diameter)	4	3
			10d box (3 × 0.128 × 0.312 head diameter)	6	4

For SI: 1 inch = 25.4 mm, 1 pound per square foot = 0.0479 kPa.

- a. Fasteners shall comply with Sections R703.3.2 and R703.3.3.
- b. Maximum spacing of soffit framing members shall not exceed 24 inches.
- c. Wood structural panels shall be of an exterior exposure grade.
- d. Wood structural panels shall be installed with strength axis perpendicular to supports with not fewer than two continuous spans.
- e. Wood structural panels shall be attached to soffit framing members with specific gravity of at least 0.42. Framing members shall be minimum 2 × 3 nominal with the larger dimension in the cross section aligning with the length of fasteners to provide sufficient embedment depths.
- f. Spacing at intermediate supports shall be not greater than 12 inches on center.

CHAPTER 8

ROOF-CEILING CONSTRUCTION

SECTION R801 GENERAL

R801.4 Drainage control. Where required by the building official, all dwellings shall have a controlled method of water disposal from roofs that will collect and discharge all roof drainage in accordance with the *Plumbing Code*.

SECTION R802 WOOD ROOF FRAMING

R802.3 Ridge. A ridge board used to connect opposing rafters shall be not less than 1 inch (25 mm) nominal thickness and not less in depth than the cut end of the rafter. Where ceiling joist or rafter ties do not provide continuous ties across the structure **as required by Section R802.5.2, the ridge shall be supported by a wall or ridge beam designed in accordance with [Section R301.1.3](#) ~~accepted engineering practice~~ and supported on each end by a wall or column.**

R802.7.2 Engineered wood products. Cuts, notches and holes bored in trusses, *structural composite lumber*, structural glue-laminated members, cross-laminated timber members or I-joists are prohibited except where permitted by the manufacturer's recommendations or where the effects of such alterations are specifically considered in the design of the member ~~by a registered design professional.~~

R802.9 Framing of openings. Openings in roof and ceiling framing shall be framed with header and trimmer joists. Where the header joist span does not exceed 4 feet (1219 mm), the header joist shall be permitted to be a single member the same size as the ceiling joist or rafter. Single trimmer joists shall be permitted to be used to carry a single header joist that is located within 3 feet (914 mm) of the trimmer joist bearing. Where the header joist span exceeds 4 feet (1219 mm), the trimmer joists and the header joist shall be doubled and of sufficient cross section to support the ceiling joists or rafter framing into the header. *Approved* hangers shall be used for the header joist to trimmer joist connections where the header joist span exceeds 6 feet (1829 mm). Tail joists over 12 feet (3658 mm) long shall be supported at the header by framing anchors or on ledger strips not less than 2 inches by 2 inches (51 mm by 51 mm). In all structures in *Seismic Design Categories D₀*, *D₁* and *D₂* and in townhouses in *Seismic Design Category C*, openings on a roof shall comply with the requirements of [Section R301.2.2.6, Item 4](#).

R802.10.2 Design. Wood trusses shall be designed in accordance with ~~accepted engineering practice~~ [Section R301.1.3](#). The design and manufacture of metal-plate-connected wood trusses shall comply with ANSI/TPI 1. ~~The truss design drawings shall be prepared by a registered design professional where required by the statutes of the jurisdiction in which the project is to be constructed in accordance with [Section R106.1](#).~~

R802.10.4 Alterations to trusses. Truss members shall not be cut, notched, drilled, spliced or otherwise altered in any way except where specifically permitted by the manufacturer's recommendations or where the effects of such alterations are specifically considered in the design of the truss ~~without the approval of a registered design professional~~. Alterations resulting in the addition of load such as HVAC equipment water heater that exceeds the design load for the truss shall not be permitted without verification that the truss is capable of supporting such additional loading.

R802.11.1 Truss uplift resistance. Trusses shall be attached to supporting wall assemblies by connections capable of resisting uplift forces as specified on the *truss design drawings* for the [basic](#) design wind speed ~~as determined by [Figure R301.2\(2\)](#) and listed in [Table R301.2](#) or as shown on the *construction documents*~~. Uplift forces shall be permitted to be determined as specified by [Table R802.11](#), if applicable, or as determined by ~~accepted engineering practice~~ [Section R301.1.3](#).

R802.11.2 Rafter uplift resistance. Individual rafters shall be attached to supporting wall assemblies by connections capable of resisting uplift forces as determined by [Table R802.11](#) or as determined by ~~accepted engineering practice~~ [Section R301.1.3](#). Connections for beams used in a roof system shall be designed in accordance with ~~accepted engineering practice~~ [Section R301.1.3](#).

SECTION R803 ROOF SHEATHING

R803.2.3 Installation. *Wood structural panel* used as roof sheathing shall be installed with joints staggered or not staggered in accordance with Table R602.3(1), [Table R602.3\(2\)](#), APA E30 for wood roof framing or with Table R804.3 for cold-formed steel roof framing. Wood structural panel roof sheathing in accordance with Table R503.2.1.1(1) shall not cantilever more than 9 inches (229 mm) beyond the gable endwall unless supported by gable overhang framing.

SECTION R804 COLD-FORMED STEEL ROOF FRAMING

R804.1.1 Applicability limits. The provisions of this section shall control the construction of cold-formed steel roof framing for buildings not greater than 60 feet (18 288 mm) perpendicular to the joist, rafter or truss span, not greater than 40 feet (12 192 mm) in width parallel to the joist span or truss, less than or equal to three stories above *grade* plane and with roof slopes not less than 3:12 (25-percent slope) or greater than 12:12 (100-percent slope). Cold-formed steel roof framing constructed in accordance with the provisions of this section shall be limited to sites where the [basic](#) design wind speed is less than 140 miles per hour (63 m/s), Exposure Category B or C, and the ground snow load is less than or equal to 70 pounds per square foot (3350 Pa). [In all structures in Seismic Design Categories D₀, D₁ and D₂ and in townhouses in Seismic Design Category C, cold-formed steel roof framing shall comply with the requirements of Section R301.2.2.6.](#)

SECTION R806 ROOF VENTILATION

R806.2 Minimum vent area. *Reference to climate zones 6, 7 and 8 in exception item 1 is removed.*

R806.5 Unvented attic and unvented enclosed rafter assemblies. Unvented *attics* and unvented enclosed roof framing assemblies created by ceilings that are applied directly to the underside of the roof framing members and structural roof sheathing applied directly to the top of the roof framing members/rafters, shall be permitted where all the following conditions are met:

1. The unvented *attic* space is completely within the *building thermal envelope*.
2. Interior Class I vapor retarders are not installed on the ceiling side (*attic* floor) of the unvented *attic* assembly or on the ceiling side of the unvented enclosed roof framing assembly.
3. [A minimum insulation level of R-20 air-impermeable or rigid board insulation shall be installed above all recessed fixtures, such as recessed lights and exhaust fans extending into air-permeable insulation.](#)
4. Where wood shingles or shakes are used, a minimum 1/4-inch (6.4 mm) vented airspace separates the shingles or shakes and the roofing underlayment above the structural sheathing.
5. ~~In Climate Zones 5, 6, 7 and 8, a~~ Any *air-impermeable insulation* shall be a Class II vapor retarder, or shall have a Class II vapor retarder coating or covering in direct contact with the underside of the insulation.
6. [Insulation shall comply with Item 5.3 and either Item 5.1-6.1, 6.2 or 6.3-5.2: Where preformed insulation board is used as the air-impermeable insulation layer, as specified in the items below, it shall be sealed at the interior perimeter of each individual sheet to form a continuous layer.](#)

~~5.1. Item 5.1.1, 5.1.2, 5.1.3 or 5.1.4 shall be met, depending on the air permeability of the insulation directly under the structural roof sheathing.~~

~~6.1-5.1.1.~~ Where only *air-impermeable insulation* is provided, it shall be applied in direct contact with the underside of the structural roof sheathing.

~~6.2-5.1.2.~~ Where *air-permeable insulation* is installed directly below the structural sheathing, rigid board or sheet insulation shall be installed directly above the structural roof sheathing ~~in accordance with the R values in Table R806.5 to an insulation level not less than R-20~~ for condensation control.

~~6.3-5.1.3.~~ Where both *air-impermeable* and *air-permeable insulation* are provided, the *air-impermeable insulation* shall be applied in direct contact with the underside of the structural roof sheathing ~~in accordance with Item 5.1.1 and shall be in accordance with the R values in Table R806.5 for condensation control~~ [to an insulation level not less than R-20](#). The *air-permeable insulation* shall be installed directly under the *air-impermeable insulation*.

[The rest of this section is not adopted and is deleted.]

IRC Table R806.5 Insulation for Condensation Control. *...Not adopted.*

CHAPTER 9

ROOF ASSEMBLIES

SECTION R901 GENERAL

R901.1 Scope. The provisions of this chapter shall govern the design, materials, construction and quality of *roof assemblies*. [See Section R327, Wildfire Hazard Mitigation, for additional roofing material requirements.](#)

SECTION R902 FIRE CLASSIFICATION

R902.1 Roof covering materials. Roofs shall be covered with materials as set forth in Sections R904 and R905. Class A, B or C roofing shall be installed in *jurisdictions* designated by law as requiring their use or where the edge of the roof is less than 3 feet (914 mm) from a *lot line*. Class A, B and C roofing required by this section to be *listed* shall be tested in accordance with ASTM E108 or UL 790. [Roof assemblies with coverings of brick, masonry, slate, clay or concrete roof tile, exposed concrete roof deck, ferrous or copper shingles or sheets, and metal sheets or shingles shall be considered Class A roof assemblies.](#)

Exceptions:

- ~~1. Class A roof assemblies include those with coverings of brick, masonry and exposed concrete roof deck.~~
- ~~2. Class A roof assemblies include ferrous or copper shingles or sheets, metal sheets and shingles, clay or concrete roof tile, or slate installed on noncombustible decks.~~
- ~~3. Class A roof assemblies include minimum 16 ounces per square foot (4.882 kg/m²) copper sheets installed over combustible decks.~~
- ~~4. Class A roof assemblies include slate installed over underlayment over combustible decks.~~

IRC R902.3 Building-integrated photovoltaic product. ...*Not adopted.*

IRC R902.4 Rooftop-mounted photovoltaic panel systems. ...*Not adopted.*

SECTION R905 REQUIREMENTS FOR ROOF COVERINGS

R905.1.1 Underlayment. *Underlayment* for asphalt shingles, clay and concrete tile, *metal roof shingles*, mineral-surfaced roll roofing, slate and slate-type shingles, wood shingles, wood shakes, *metal roof panels* and *photovoltaic shingles* shall conform to the applicable standards listed in this chapter. *Underlayment* materials required to comply with ASTM D226, D1970, D4869 and D6757 shall bear a *label* indicating compliance to the standard designation and, if applicable, type classification indicated in Table R905.1.1(1). *Underlayment* shall be applied in accordance with Table R905.1.1(2). *Underlayment* shall be attached in accordance with Table R905.1.1(3).

Exceptions:

- As an alternative, self-adhering polymer-modified bitumen underlayment **bearing a label indicating compliance** with ASTM D1970.
- As an alternative, a minimum 4-inch-wide (102 mm) strip of self-adhering polymer-modified bitumen membrane **bearing a label indicating** compliance with ASTM D1970, installed in accordance with the *manufacturer's installation instructions* for the deck material, shall be applied over all joints in the roof decking. An *approved underlayment complying with Table R905.1.1(1)* for the applicable roof covering ~~for areas where wind design is not required in accordance with Figure R301.2.1.1~~ shall be applied over the entire roof over the 4-inch-wide (102 mm) membrane strips. **Underlayment shall be applied in accordance with Table R905.1.1(2) using the application requirements for areas where wind design is not required in accordance with Figure R301.2.1.1.** *Underlayment* shall be attached in accordance with Table R905.1.1(3).

R905.1.2 Ice barriers. In areas where [the average daily temperature in January is 25°F \(-4°C\) or less](#) or where there has been a history of ice forming along the eaves causing a backup of water ~~as designated in Table R301.2~~, an ice barrier shall be installed for asphalt shingles, metal roof shingles, mineral-surfaced roll roofing, slate and slate-type shingles, wood shingles and wood shakes. *[The rest of this section remains unchanged.]*

Table R905.1.1(1) Underlayment Types. *Third column of the table is renamed “Underlayment Type” and the Fourth column is deleted.*

Table R905.1.1(2) Underlayment Application. *Third column of the table is renamed “Underlayment Application” and the Fourth column is deleted.*

Table R905.1.1(3) Underlayment Attachment. *Third column of the table is renamed “Underlayment Attachment” and the Fourth column is deleted.*

**TABLE R905.2.4.1
CLASSIFICATION OF ASPHALT ROOF SHINGLES**

MAXIMUM ULTIMATE BASIC DESIGN WIND SPEED, V_{ult} FROM TABLE R301.2 (mph)	MAXIMUM BASIC WIND SPEED, V_{ASD} FROM TABLE R301.2.1.2 (mph)	ASTM D7158 ^a SHINGLE CLASSIFICATION	ASTM D3161 SHINGLE CLASSIFICATION
110	85	D, G or H	A, D or F
116	90	D, G or H	A, D or F
129	100	G or H	A, D or F
142	110	G or H	F
155	120	G or H	F
168	130	H	F
181	140	H	F
194	150	H	F

For SI: 1 foot = 304.8 mm, 1 mile per hour = 0.447 m/s.

- a. The standard calculations contained in ASTM D7158 assume Exposure Category B or C and a building height of 60 feet or less. Additional calculations are required for conditions outside of these assumptions.

R905.2.8.3 Sidewall flashing. [Flashing against a vertical sidewall shall be by the step-flashing method. The flashing shall be a minimum of 4 inches \(102 mm\) in height and 4 inches \(102 mm\) in width. At the end of the vertical sidewall, the step flashing shall be turned out in a manner that directs water away from the wall and onto the roof or gutter. See Figure R703.4\(1\).](#) ~~Base flashing against a vertical sidewall shall be continuous or step flashing and shall be not less than 4 inches (102 mm) in height and 4 inches (102 mm) in width and shall direct water away from the vertical sidewall onto the roof or into the gutter. Where siding is provided on the vertical sidewall, the vertical leg of the flashing shall be continuous under the siding. Where anchored masonry veneer is provided on the vertical sidewall, the base flashing shall be provided in accordance with this section and counterflashing shall be provided in accordance with Section R703.8.2.2. Where exterior plaster or adhered masonry veneer is provided on the vertical sidewall, the base flashing shall be provided in accordance with this section and Section R703.6.3.~~

Section R905.4.4 – Model code change:

Requirements for metal shingle wind resistance have been added.

R905.4.4 Material standards. *Metal roof shingle* roof coverings shall comply with Table R905.10.3(1). The materials used for *metal roof shingle* roof coverings shall be naturally corrosion resistant or be made corrosion resistant in accordance with the standards and minimum thicknesses listed in Table R905.10.3(2).

R905.4.4.1 Wind resistance of metal roof shingles. *Metal roof shingles* applied to a solid or closely fitted deck shall be tested in accordance with ASTM D3161, FM 4474, UL 580 or UL 1897. *Metal roof shingles* tested in accordance with ASTM D3161 shall meet the classification requirements of Table R905.4.4.1 for the appropriate maximum basic wind speed and the metal shingle packaging shall bear a *label* to indicate compliance with ASTM D3161 and the required classification in Table R905.2.4.1.

**TABLE R905.4.4.1
CLASSIFICATION OF STEEP SLOPE METAL ROOF SHINGLES TESTED IN ACCORDANCE WITH ASTM D3161**

MAXIMUM BASIC DESIGN WIND SPEED, V_{ult} , FROM TABLE R301.2 (mph)	MAXIMUM BASIC ALLOWABLE STRESS DESIGN WIND SPEED, V_{ASD} , FROM TABLE R301.2.1.2 (mph)	ASTM D3161 SHINGLE CLASSIFICATION
110	85	A, D or F
116	90	A, D or F
129	100	A, D or F
142	110	F
155	120	F
168	130	F
181	140	F
194	150	F

For SI: 1 mile per hour = 1.609 kph.

**TABLE R905.16.6
CLASSIFICATION OF PHOTOVOLTAIC SHINGLES**

MAXIMUM BASIC DESIGN WIND SPEED, V_{ult} , FROM TABLE R301.2 (mph)	MAXIMUM BASIC ALLOWABLE STRESS DESIGN WIND SPEED, V_{ASD} , FROM TABLE R301.2.1.2 (mph)	UL 7103 SHINGLE CLASSIFICATION
110	85	A, D or F
116	90	A, D or F
129	100	A, D or F
142	110	F
155	120	F
168	130	F
181	140	F
194	150	F

For SI: 1 mile per hour = 1.609 kph.

SECTION R908 REROOFING

R908.1 General. Materials and methods of application used for recovering or replacing an existing roof covering shall comply with the requirements of Chapter 9 and the roof covering manufacturer's installation instructions. *[The exceptions remain unchanged.]*

R908.1.1 Ventilation. Where sheathing is replaced prior to the installation of a new roof covering, ventilation in the affected areas shall be provided in accordance with Section R806.

CHAPTER 10

CHIMNEYS AND FIREPLACES

Note: Pursuant to ORS 215.730, if a single-family dwelling located on forest-zoned lands has a chimney or chimneys, each chimney shall have a spark arrestor.

SECTION R1001 MASONRY FIREPLACES

R1001.2 Footings and foundations. Footings for masonry fireplaces and their chimneys shall be constructed of concrete or *solid masonry* not less than 12 inches (305 mm) thick and shall extend not less than 6 inches (152 mm) beyond the face of the fireplace or foundation wall on all sides. Footings shall be founded on natural, undisturbed earth or ~~engineered~~ approved fill below frost depth. In areas not subjected to freezing, footings shall be not less than 12 inches (305 mm) below finished *grade*.

SECTION R1003 MASONRY CHIMNEYS

R1003.2 Footings and foundations. Footings for *masonry chimneys* shall be constructed of concrete or *solid masonry* not less than 12 inches (305 mm) thick and shall extend not less than 6 inches (152 mm) beyond the face of the foundation or support wall on all sides. Footings shall be founded on natural undisturbed earth or approved ~~engineered~~ fill below frost depth. In areas not subjected to freezing, footings shall be not less than 12 inches (305 mm) below finished *grade*.

CHAPTER 11

ENERGY EFFICIENCY

PART I—ENERGY CONSERVATION

SECTION N1101 SCOPE

N1101.1 General. The provisions of this chapter regulate the exterior envelope, as well as the design, construction and selection of heating, ventilating and air-conditioning systems, piping insulation, [lighting and power](#) required for the purpose of effective conservation of energy within a building or structure governed by this code.

All *conditioned spaces* within residential buildings shall comply with Table N1101.1(1) and one additional measure from Table N1101.1(2). [New buildings using Section N1105.3, Exception 3, shall comply with two additional measures from Table N1101.1\(2\).](#)

Exceptions:

1. Application to existing buildings shall comply with Section N1101.2.
2. Application to additions shall comply with Section N1101.3.
3. Heated or cooled detached *accessory structures* that are not habitable shall meet the following envelope requirements without any additional measures (walls: R-21/U-0.064; heated slab interior: R-10 under entire slab; underfloors: R-30; roofs: R-38/U-0.027 (attic) or R-20 continuous insulation/U-0.048 (above deck); windows: U-0.35; opaque doors: U-0.70; roll-up doors: U-0.50.)

[Note: For reference only. Not adopted by the State of Oregon, Building Codes Division, as part of the state building code.](#)

[Energy incentives: This code sets minimum performance standards for buildings constructed under the Building Code.](#)

[Incentives for exceeding the provisions of this code can be found at: Oregon.gov/energy/incentives.](#)

N1101.2 Application to existing buildings. *Alterations and repairs, historic buildings* and change of use or occupancy to buildings, structures or portions thereof shall comply with the requirements in Sections N1101.2.1 through N1101.2.3.

N1101.2.1 Alterations and repairs. *Alterations and repairs* affecting energy conservation measures shall conform to the requirements specified in this chapter.

Where alterations or repairs affect components of existing *conditioned spaces* regulated in this chapter, those components shall comply with this chapter.

Exception: [The minimum existing component requirements as specified in Table N1101.2 shall be used to the maximum extent technically practical due to existing constraints, which may include but are not limited to the available cavity depth, matching existing features and similar constraints.](#)

N1101.2.2 Historic buildings. The *building official* may modify the specific requirements of this chapter for *historic buildings* and require in lieu thereof alternative requirements that will result in a reasonable degree of energy efficiency. This modification may be allowed for those buildings specifically designated as historically significant by the state historic preservation office(r) or by official action of a local government.

N1101.2.3 Change of occupancy or use. Definition of “change of use” for purposes of Section N1101.2.3.1 is a change of use in an existing *residential building* and shall include any of the following: any unconditioned spaces such as an attached garage, basement, porch, *attic* or canopy that are to become *conditioned spaces*.

N1101.2.3.1 Change of use. A building that changes use, without any changes to the components regulated in this chapter, is required to comply with Table N1101.2 to the greatest extent practical. Changes of use that are greater than 30 percent of the existing building heated floor area or more than 400 square feet (37 m²) in area, whichever is less, shall be required to comply with one measure from Table N1101.3.2.

N1101.2.3.2 Change of occupancy. Alteration and repair of conditioned nonresidential buildings, such as a change of occupancy from a small church or school to a residential dwelling shall use Table N1101.2 to the greatest extent practical and comply with one measure from Table N1101.1(2) or Table N1101.3.2.

Exception: The minimum component requirements shall be disregarded where thermal performance calculations are completed for change of use to a Group R-3 occupancy, where such calculations demonstrate similar performance to the requirements of Table N1101.2.

**TABLE N1101.2
EXISTING BUILDING COMPONENT REQUIREMENTS**

BUILDING COMPONENTS	REQUIRED PERFORMANCE	EQUIVALENT VALUE
Wall insulation	U-0.083	R-15
Flat ceiling	U-0.025	R-49
Vaulted ceiling >10 inches nominal rafter depth	U-0.040	R-25
Vaulted ceiling ≤10 inches nominal rafter depth	U-0.047	R-21
Underfloor > 10 inches nominal joist depth	U-0.028	R-30
Underfloor ≤10 inches nominal joist depth	U-0.039	R-25
Slab-edge perimeter	F-0.52 N/A	R-15 N/A
Windows and glazed doors	U-0.30	U-0.30
Skylights	U-0.50	U-0.50
Exterior doors	U-0.20	R-5
Exterior doors with >2.5 ft ² glazing	U-0.40	R-2.5
Forced air ducts	N/A	R-8

For SI: Inch = 25.4 mm, 1 square foot = 0.0929 m².
N/A = Not Applicable.

**TABLE N1101.1(1)
PRESCRIPTIVE ENVELOPE REQUIREMENTS^a**

BUILDING COMPONENT	STANDARD BASE CASE		LOG HOMES ONLY	
	Required Performance	Equivalent Value ^b	Required Performance	Equivalent Value ^b
Wall insulation—above grade	U-0.059 ^c	R-21 Intermediate ^c	Note d	Note d
Wall insulation—below grade ^c	C-0.063	R-15 c.i./R-21	C-0.063	R-15/R-21
Flat ceilings ^f	U-0.021	R-49	U-0.020	R-49 A ^h
Vaulted ceilings ^g	U-0.033	R-30 Rafter or R-30A ^{g,h} Scissor Truss	U-0.027	R-38A ^h
Underfloors	U-0.033	R-30	U-0.033	R-30
Slab-edge perimeter ⁱ	F-0.520	R-15	F-0.520	R-15
Heated slab interior ⁱ	N/A	R-10	N/A	R-10
Windows ^j	U-0.27	U-0.27	U-0.27	U-0.27
Skylights	U-0.50	U-0.50	U-0.50	U-0.50
Exterior doors ^k	U-0.20	U-0.20	U-0.54	U-0.54

For SI: 1 inch = 25.4 mm, 1 square foot = 0.0929 m², 1 degree = 0.0175 rad
N/A = Not Applicable.

- a. As allowed in Section N1104.1, thermal performance of a component may be adjusted, provided that overall heat loss does not exceed the total resulting from conformance to the required *U*-factor standards. Calculations to document equivalent heat loss shall be performed using the procedure and approved *U*-factors contained in Table N1104.1(1).
- b. *R*-values used in this table are nominal for the insulation only in standard wood-framed construction and not for the entire assembly.
- c. Wall insulation requirements apply to all exterior wood-framed, concrete or masonry walls that are above grade. This includes cripple walls and rim joist areas. Nominal compliance with R-21 insulation and Intermediate Framing (Section N1104.5.2) with insulated headers.
- d. The wall component shall be a minimum solid log or timber wall thickness of 3½ inches.
- e. Below-grade wood, concrete or masonry walls include all walls that are below grade and do not include those portions of such wall that extend more than 24 inches above grade. R-21 for insulation in framed cavity, R-15 continuous insulation.
- f. Insulation levels for ceilings that have limited attic/rafter depth such as dormers, bay windows or similar architectural features totaling not more than 150 square feet in area may be reduced to not less than R-21. Where reduced, the cavity shall be filled (except for required ventilation spaces). R-49 insulation installed to minimum 6-inch depth at top plate at exterior of structure to achieve *U*-factor.
- g. Vaulted ceiling surface area exceeding 50 percent of the total heated space floor area shall have a *U*-factor not greater than U-0.026 (equivalent to R-38 rafter or scissor truss with R-38 advanced framing).
- h. A = Advanced frame construction. See Section N1104.6.
- i. Heated slab interior applies to concrete slab floors (both on and below grade) that incorporate a radiant heating system within the slab. Insulation shall be installed underneath the entire slab in addition to perimeter insulation.
- j. Glass doors shall comply with window performance requirements. Windows exempt from testing in accordance with Section N1104.4 shall comply with window performance requirements if constructed with aluminum with thermal break, wood, vinyl, reinforced vinyl aluminum-clad wood, or insulated fiberglass frames, and double-pane glazing with low-emissivity coatings of 0.10 or less. Buildings designed to incorporate passive solar elements may include glazing with a *U*-factor greater than 0.35 by using Table N1104.1(1) to demonstrate equivalence to building envelope requirements.
- k. A maximum of 28 square feet of exterior door area per dwelling unit may have a *U*-factor of 0.54 or less.
- l. Minimum 24-inch horizontal or vertical below grade. The minimum total distance of 24 inches may be a combination of the horizontal and vertical planes. If a horizontal plane is used on the exterior of the slab, it must be a minimum of 12 inches below finished grade.

**TABLE N1101.1(2)
ADDITIONAL MEASURES**

MEASURE NO.	MEASURE DESCRIPTION
1	HIGH-EFFICIENCY HVAC SYSTEM^a a. Gas-fired furnace or boiler AFUE 94 percent, or b. Air source heat pump HSPF 10.0/ 14.0 <u>16.0</u> SEER cooling <u>or 8.5 HSPF2 / 15.0 SEER2</u> , c. Ground-source heat pump COP 3.5 or ENERGY STAR rated.
2	HIGH-EFFICIENCY WATER HEATING SYSTEM a. Natural gas/propane water heater with minimum 0.90 UEF, or b. Electric heat pump water heater with minimum 2.0 COP <u>3.45 UEF</u> , or c. Natural gas/propane tankless/instantaneous heater with minimum 0.80 UEF and drain water heat recovery unit installed on a minimum of one shower/tub-shower.
3	WALL INSULATION UPGRADE Exterior walls—U-0.045/R-21 conventional framing with R-5.0 continuous insulation
4	ADVANCED ENVELOPE Windows—U-0.21 (Area-weighted average), and Flat ceiling ^b —U-0.017/R-60, and Framed floors—U-0.026/R-38 or slab edge insulation to F-0.48 or less (R-10 for 48"; R-15 for 36" or R-5 fully insulated slab)
5	DUCTLESS HEAT PUMP (Dwelling units with all-electric heat) a. Provide ductless heat pump of minimum HSPF 10.0 <u>or HSPF2 9.0</u> in primary zone replaces zonal electric heat sources, and b. Provide programmable thermostat for all heaters in bedrooms
6	HIGH-EFFICIENCY THERMAL ENVELOPE UA^c Proposed UA is 8 percent lower than the code UA
7	GLAZING AREA Glazing area, measured as the total of framed openings is less than 12 percent of conditioned floor area.
7.8	2.75 3.0 ACH AIR LEAKAGE CONTROL AND EFFICIENT VENTILATION Achieve a maximum of <u>2.75</u> 3.0 ACH50 whole-house air leakage when third-party tested and provide a whole-house ventilation system, including heat recovery with a minimum sensible heat recovery efficiency of not less than 66 percent <u>and total fan efficacy of 1.6 CFM/Watt (combined input for supply and exhaust).</u>

For SI: 1 square foot = 0.093 m², 1 watt per square foot = 10.8 W/m².

- Appliances located within the building thermal envelope shall have sealed combustion air installed. Combustion air shall be ducted directly from the outdoors.
- The maximum vaulted ceiling surface area shall not be greater than 50 percent of the total heated space floor area unless vaulted area has a U-factor not greater than U-0.026.
- In accordance with Table N1104.1(1), the Proposed UA total of the Proposed Alternative Design shall be a minimum 8 percent less than the Code UA total of the Standard Base Case.

N1101.3 Additions. Additions to existing buildings or structures may be made without making the entire building or structure comply if the new additions comply with the requirements of this chapter.

N1101.3.1 Large additions. Additions that are equal to or more than 600 square feet (56 m²) in area shall be required to comply with one measure from Table N1101.1(2).

N1101.3.2 Small additions. Additions that are less than 600 square feet (56 m²) in area shall be required to comply with [one measure](#) from Table N1101.1(2) or comply with Table N1101.3.2.

Exception: Additions that are less than 225 square feet (20.9 m²) in area shall not be required to comply with Table N1101.1(2) or Table N1101.3.2.

N1101.4 Information on plans and specifications. Plans and specifications shall show in sufficient detail all pertinent data and features of the building and the equipment and systems as herein governed, including, but not limited to: exterior envelope component materials; R-values of insulating materials;

fenestration U-factors; HVAC equipment efficiency performance and system controls; [ductwork location](#); lighting; the additional measure(s) from Table N1101.1(2); and the other pertinent data to indicate compliance with the requirements of the chapter.

SECTION N1102 DEFINITIONS

AFUE (ANNUAL FUEL UTILIZATION EFFICIENCY). The energy output divided by the energy input, calculated on an annual basis and including part load and cycling effects. AFUE ratings shall be determined using the US Department of Energy test procedures (10 CFR Part 430).

AUTOMATIC. Self-acting, operating by its own mechanism when actuated by some impersonal influence, such as a change in current strength, pressure, temperature or mechanical configuration. (See “Manual.”)

BASEMENT WALL. The opaque portion of any wall which encloses a basement and is partially or totally below grade.

TABLE N1101.3.2
SMALL ADDITION ADDITIONAL MEASURES (select one)

MEASURE NO.	MEASURE DESCRIPTION
1	Increase the ceiling insulation of the existing portion of the home as specified in Table N1101.2.
2	Replace all existing single-pane wood or aluminum windows to the <i>U</i> -factor as specified in Table N1101.2
3	Insulate the existing floor, crawl space or basement wall systems as specified in Table N1101.2 and install 100 percent of permanently installed lighting fixtures as CFL, LED or linear fluorescent, or a minimum efficacy of 40 lumens per watt as specified in Section N1107.2.
4	Test the entire dwelling with a blower door and exhibit not more than 4.5 air changes per hour @ 50 Pascals.
5	Seal and performance test the duct system.
6	Replace existing 80-percent AFUE or less gas furnace with a 94.92 94.92-percent AFUE or greater system.
7	Replace existing electric radiant space heaters with a ductless mini split system with a minimum HSPF of 10.0 <u>or HSPF2 of 9.0.</u>
8	Replace existing electric forced-air furnace with an air source heat pump with a minimum HSPF of 9.5 <u>or HSPF2 of 8.1.</u>
9	Replace existing water heater with one of the following: a. Natural gas/propane water heater with minimum UEF 0.90, or b. Electric heat pump water heater with minimum 2.0 COP <u>3.45 UEF.</u>

BELOW-GRADE WALLS. The walls or the portion of walls entirely below the finished grade or which extend 2 feet (610 mm) or less above the finished grade.

BTU (British Thermal Unit). The amount of heat required to raise the temperature of 1 pound (0.454 kg) of water (about 1 pint) from 59°F to 60°F (15°C to 16°C).

BUILDING THERMAL ENVELOPE. That element of a building that encloses conditioned spaces through which thermal energy may be transmitted to or from the exterior or to or from unconditioned spaces.

C (Thermal Conductance). See “*Thermal conductance.*”

CONDITIONED SPACE. A space within the building, separated from unconditioned space by the *building thermal envelope*, which by introduction of conditioned air, by heated and/or cooled surfaces, or by air or heat transfer from directly conditioned spaces is maintained at temperatures of 55°F (13°C) or higher for heating and/or 85°F (29.4°C) or below for cooling. (Enclosed corridors between conditioned spaces shall be considered as conditioned space. Spaces where temperatures fall between this range by virtue of ambient conditions shall not be considered *conditioned space.*)

COOLED SPACE. A space within a building provided with a mechanical cooling supply.

EXTERIOR DOOR. A permanently installed operable barrier by which an entry is closed and opened. Exterior doors include doors between conditioned and unconditioned spaces, such as a door between a kitchen and garage.

EXTERIOR ENVELOPE. See “*Building thermal envelope.*”

EXTERIOR WALL. Any member, or group of members, that defines the exterior boundaries of the *conditioned space*, and which has a slope of 60 degrees (1.05 rad) or greater with the horizontal plane.

EXTERIOR WINDOW. An opening, especially in the wall of a building, for admission of light or air that is usually closed by casement or sashes containing transparent material (such as

glass) and in some cases capable of being opened and shut. All areas, including frames, in the shell of a *conditioned space* that let in natural light, including skylights, sliding glass doors, glass block walls and the glazed portions of the doors.

When calculating the energy performance of the exterior envelope, the area of the window shall be the total *glazing area* measured using the rough opening dimensions, including the glass, sash and frame.

FENESTRATION. Windows and doors in the exterior envelope. See “*Exterior door*” and “*Exterior window.*”

FLOOR AREA. The area included within the surrounding exterior walls of a building or portion thereof, exclusive of exterior courts. The floor area of a building or portion thereof not provided with surrounding exterior walls shall be the usable area under the horizontal projection of the roof or floor above.

GLAZING. All areas including frames in the shell of a *conditioned space* that let in natural light, including windows, clerestories, skylights, sliding glass doors, glass block walls and the glazed portion of doors.

GROSS AREA OF EXTERIOR WALLS. Wall areas, as measured on the exterior, including foundation walls above grade; peripheral edges of floors; window areas, including sash; and door areas, where such surfaces are exposed to outdoor air and enclose a heated or mechanically cooled space.

HEATED SPACE. A space within a building served by a mechanical, electrical or combustion source of heat. Spaces within a basement shall be defined as heated when any of the following apply: the space is finished, has heating registers or contains heating devices.

HIGH-EFFICIENCY LIGHT SOURCE. Compact fluorescent lamps, T-8 or smaller diameter linear fluorescent lamps, LED lamps, fixture-integrated illumination devices, or lamps with an efficacy not less than 65 lumens per watt for each lamp or luminaires with an efficacy not less than 45 lumens per watt for each luminaire.

HSPF (HEATING SEASONAL PERFORMANCE FACTOR). The total heating output of a heat pump during its normal annual usage period for heating divided by the total electric power input in watt-hours during the same period.

HUMIDISTAT. An instrument which measures changes in humidity and controls a device or devices to maintain a desired humidity.

HVAC (HEATING, VENTILATING AND AIR-CONDITIONING) SYSTEM. Refers to the equipment, distribution network and terminals that provide either collectively or individually the processes of heating, ventilating and/or air-conditioning processes to a building.

K (THERMAL CONDUCTIVITY). See “*Thermal conductivity*.”

MANUAL (nonautomatic). Action requires human intervention as the basis for control (see “*Automatic*”).

OTHER BUILDINGS. All buildings and structures, or portions thereof, that are not defined as residential buildings (see “*Residential buildings*”).

PERM RATING (DRY CUP). The measure of the ability of a material of specific thickness to transmit moisture in terms of the amount of moisture transmitted per unit time for a specified area and differential pressure. Dry cup perm rating is expressed in [grain/h-ft²-in Hg (0°C)]. Permeance may be measured by using ASTM E96 or other *approved* dry cup method. The closer the dry cup perm rating approaches zero, the better the vapor retarder. Permeability is defined as the permeance of a material for specified unit length (perm/in).

R (THERMAL RESISTANCE). See “*Thermal resistance*.”

R_t (THERMAL RESISTANCE TOTAL). See “*Thermal resistance total*.”

RESIDENTIAL BUILDINGS. Buildings and structures, or portions thereof, housing Group R occupancies that are three stories or less in height.

THERMAL CONDUCTANCE (C). The constant time rate of heat flow through a unit area of a body induced by a unit temperature difference between the surfaces (Btu/h × ft² × °F) [W/(m² × K)].

It is the reciprocal of thermal resistance (see “*Thermal resistance*”).

THERMAL CONDUCTIVITY (K). The rate of heat flow through 1 square foot (0.0929 m²) of a homogeneous material 1 inch (25.4 mm) in thickness when there is a temperature difference of 1°F (0.56°C) between the opposite faces of the material, expressed as Btu/h per square foot per °F temperature difference. Thermal conductivity is similar to thermal conductance (C), except thermal conductance applies to the actual thickness of the material.

THERMAL RESISTANCE (R). The measure of the resistance of a material or building component to the passage of heat has the value of (h × ft² × °F/Btu) [(m² × K)/W] and is the reciprocal of thermal conductance.

THERMAL RESISTANCE TOTAL (R_t). The sum of the resistance for all of the individual components of the assembly, including framing members, multiple layer connections, insulation and air films expressed in (Btu/h × ft² × °F) [W/(m² × K)].

THERMAL TRANSMITTANCE (U). The coefficient of heat transfer. It is the time rate of heat flow per unit area under steady state conditions from the fluid on the warm side of the barrier to the fluid on the cold side, per unit temperature difference between the two fluids, (Btu/h × ft² × °F).

THERMOSTAT. An instrument that measures changes in temperature and controls a device or devices to maintain a desired temperature.

U-FACTOR (THERMAL TRANSMITTANCE). See “*Thermal transmittance*.”

VAULTED CEILING. A ceiling with a minimum slope of 2 in 12.

WINDOW. See “*Exterior window*.”

ZONE. A space or group of spaces within a building with heating or cooling requirements sufficiently similar so that comfort conditions can be maintained throughout by a single controlling device.

SECTION N1103 ALTERNATIVE SYSTEMS

Alternative designs may be *approved* by the *building official* when it can be demonstrated that the proposed building complies with Part II, Alternative Systems Analysis, of this chapter.

N1103.1 Design parameters. For calculations under this section, the following design parameters shall apply:

The outside temperature shall be taken from the 99-percent winter temperature values and the 1-percent summer temperature values listed in ASHRAE *Handbook of Fundamentals*. For areas not listed, the designer should obtain the most reliable design temperatures available. Selected values are subject to approval of the *building official*.

SECTION N1104 EXTERIOR ENVELOPE REQUIREMENTS

N1104.1 General. This section provides minimum requirements for exterior envelope construction.

The *exterior building envelope* shall comply with Table N1101.1(1) or shall be demonstrated using Table N1104.1(1). The requirements specified in Table N1101.1(2) shall apply to both Tables N1101.1(1) and N1104.1(1).

Buildings designed to incorporate passive solar elements may use Table N1104.1(1) to demonstrate *building thermal envelope* requirements in this code, in addition to requirements specified in Table N1101.1(2).

N1104.2 Insulation materials. Insulation materials shall be installed in accordance with manufacturer’s listing and installation instructions and this code. Insulation *R*-values shall be specified as required in 16 CFR Ch. I (1-1-91 Edition) Part 460—Labeling and Advertising of Home Insulation. Cellulose insulation shall conform to Interim Safety Standard for Cellulose Insulation (16 CFR Part 1209) issued by the Consumer Product Safety Commission July 6, 1979 (44FR 39938). Foam plastic shall be as specified in Section R316.

N1104.2.1 Insulation clearance restriction. Blown, poured, batt and spray-on type insulation applied from above the ceiling level shall be limited to vented attic spaces where the roof slope is 4 units vertical in 12 units horizontal (33.3-percent slope) or greater and there is at least 44 inches (1118 mm) of headroom at the roof ridge. (Clear headroom is defined as the distance from the top of the bottom chord of the truss or ceiling joists to the underside of the roof sheathing.) Netted or other applications that allow for verification of insulation application shall be allowed for low-slope roofs.

N1104.2.2 Batt-type insulation. Batt-type insulation shall be installed flush against the warm side of the cavity insofar as practicable.

N1104.2.3 Insulation protection. Insulation exposed to the exterior shall be protected from physical and solar damage.

N1104.2.4 Clearances. Recessed light fixtures shall be IC-labeled for direct insulation contact.

Thermal insulation shall not be installed within 3 inches (76 mm) of any metal chimney or gas vent that is not listed for insulation clearances.

A permanent sleeve of fine wire mesh screen, sheet metal or other noncombustible material shall be installed to maintain the required clearances.

N1104.2.5 Baffles. Baffles of a durable rigid material shall be provided to prevent obstruction of vent openings and to deflect incoming air above the surface of porous insulation so as to prevent wind washing and blowing of loose material. Thermal insulation shall not be installed in a manner that would obstruct openings required for attic ventilation.

**TABLE N1104.1(1)
RESIDENTIAL THERMAL PERFORMANCE CALCULATIONS**

(Errata issued April 2024)

BUILDING COMPONENTS ^b	STANDARD BASE CASE ^a			PROPOSED A		ALTERNATIVE	
	Areas ^c	<i>U</i> -factor	Areas x <i>U</i>	<i>R</i> -value ^d	Areas ^c	<i>U</i> -factor ^e	Areas x <i>U</i>
Flat ceilings		0.021					
Vaulted ceilings ^f		0.033					
Conventional wood-framed walls		0.059					
Underfloor		0.033					
Slab-edge		F = 0.52 ^g					
Below-grade walls		C = 0.063 ^g					
Windows		0.27					
Skylights		0.50					
Exterior doors ^h		0.2					
Doors with > 2.5 ft ² glazing		0.4					
Code UA =				Proposed UA ⁱ =			

- Base path 1 represents Standard Base Case from Table N1101.1(1). *U*-factors shall be adjusted to match Table N1101.1(2) for compliance with Additional Measure Number 4, if selected.
- Performance trade-offs are limited to those listed in Column 1. Heat plant efficiency, duct insulation levels, passive and active solar heating, air infiltration and similar measures, including those not regulated by this code must not be considered in this method of calculation.
- Areas from plan take-offs. All areas must be the same for both Standard Base Case and Proposed Alternative. The vaulted ceiling surface area for Standard Base Case must be the actual surface area from the plan take-off not to exceed 50 percent of the total heated space floor area. Any roof areas in excess of 50 percent for Base Case must be entered at U-0.021 (R-49) with “Flat ceilings” area.
- Minimum component requirements insofar as practicable: above-grade walls R-15/U-0.080; underfloors R-21/U-0.047; flat ceilings R-38/U-0.031; vaulted ceilings R-21/U-0.055; below-grade wood, concrete or masonry walls R-15/C-0.069; slab edge R-10/F-0.52. *R*-values used in this table are nominal, for the insulation only and not for the entire assembly. Window and skylight *U*-values shall not exceed 0.65 (CL65). A single door not to exceed 28 square feet per dwelling unit is permitted to be excluded from the thermal performance calculations. All other door-values shall not exceed 0.54 (Nominal R-2).
- U*-factors for wood-framed ceilings, walls and floor assemblies shall be as specified in Table N1104.1(2). *U*-factors for other assemblies, which include steel framing, brick or other masonry, stucco, etc., shall be calculated using ASHRAE *Handbook of Fundamentals* procedures.
- Vaulted area, unless insulated to R-38, U-0.026, shall not exceed 50 percent of the total heated space floor area.
- F* = the heat loss coefficient, Btu/h × ft² × °F per foot of perimeter. *C* = the heat loss coefficient Btu/h × ft² × °F per square foot of underground wall.
- A maximum of 28 square feet of exterior door area per dwelling unit can have a *U*-factor of 0.54 or less. Default *U*-factor for an unglazed wood door is 0.54.
- Proposed UA must be less than or equal to Code UA. For compliance with Table N1101.1(2), Additional Measure Number 6, the Proposed UA must be a minimum 8 percent less than the Code UA.

TABLE N1104.1(2)
APPROVED DEFAULT U-FACTORS

FLAT CEILINGSA			EXTERIOR WALLSA			
Insulation	Type	U-Factor	Insulation	Insulation Sheathing	Framing	U-Factor
R-38	Conventional framing	0.027	R-15	0	Conventional framing	0.083
R-38	Advanced framing ^c	0.026	R-15	0	Intermediate framing ^b	0.078
R-49	Conventional framing	0.021	R-19	0	Conventional framing	0.067
R-49	Advanced framing ^c	0.020	R-19	0	Intermediate framing ^b	0.063
R-60	Conventional framing	0.017	R-19	0	Advanced framing ^d	0.062
R-60	Advanced framing ^c	0.016	R-21	0	Conventional framing	0.063
VAULTED CEILINGSA			R-21	0	Intermediate framing ^b	0.059
Insulation	Type	U-Factor	R-21	0	Advanced framing ^d	0.057
R-21	Rafter framings	0.050	R-23	0	Conventional framing	0.059
R-30	Rafter framing	0.032	R-23	0	Intermediate framing	0.055
R-38	Rafter framing	0.026	R-23	0	Advanced framing ^d	0.053
R-21	Scissors truss	0.052	R-13	3.5 ^e	Conventional framing	0.065
R-30	Scissors truss	0.034	R-13	5 ^e	Conventional framing	0.059
R-38	Scissors truss	0.027	R-13	7 ^e	Conventional framing	0.053
R-49	Scissors truss	0.021	R-13	3.5 ^e	Advanced framing ^d	0.062
R-30	Advanced scissors truss ^c	0.032	R-13	5 ^e	Advanced framing ^d	0.056
R-38	Advanced scissors truss ^c	0.026	R-13	7 ^e	Advanced framing ^d	0.050
R-49	Advanced scissors truss ^c	0.020	R-15	3.5 ^e	Conventional framing	0.062
EPS FOAM CORE PANEL VAULTED CEILINGSA			R-15	5 ^e	Conventional framing	0.056
Insulation	Type	U-Factor	R-15	7 ^e	Conventional framing	0.050
R-29	8 1/4" EPS foam core panel	0.034	R-15	3.5 ^e	Advanced framing ^d	0.057
R-37	10 1/4" EPS foam core panel	0.027	R-15	5 ^e	Advanced framing ^d	0.052
R-44	12 1/4" EPS foam core panel	0.023	R-15	7 ^e	Advanced framing ^d	0.047
FLOORS ^a			R-19	3.5 ^e	Conventional framing	0.052
Insulation	Type	U-Factor	R-19	5 ^e	Conventional framing	0.048
R-21	Underfloor	0.046	R-19	7 ^e	Conventional framing	0.044
R-25	Underfloor	0.039	R-19	3.5 ^e	Intermediate framing ^b	0.050
R-30	Underfloor	0.033	R-19	5 ^e	Intermediate framing ^b	0.047
R-38	Underfloor	0.026	R-19	7 ^e	Intermediate framing ^b	0.043
R-49	Underfloor	0.020	R-19	3.5 ^e	Advanced framing ^d	0.049
SLAB-ON-GRADE			R-19	5 ^e	Advanced framing ^d	0.046
Insulation	Type	F-Factor ^f	R-19	7 ^e	Advanced framing ^d	0.042
R-10	Slab edge 24"	0.54	R-21	3.5 ^e	Conventional framing	0.049
R-15	Slab edge 24"	0.52	R-21	5 ^e	Conventional framing	0.045
R-20	Slab edge 24"	0.51	R-21	3.5 ^e	Intermediate framing ^b	0.047
R-5	Slab edge 48"	0.48	R-21	5 ^e	Intermediate framing ^b	0.044
R-15	Slab edge 48"	0.45	R-21	7 ^e	Intermediate framing ^b	0.040
R-20	Slab edge 48"	0.43	R-21	3.5 ^e	Advanced framing ^d	0.046
R-5	Under slab continuous	0.46	R-21	5 ^e	Advanced framing ^d	0.043
R-7.5	Under slab continuous	0.41	R-21	7 ^e	Advanced framing ^d	0.039
R-10	Under slab continuous	0.36	R-21	3.5 ^e	Advanced framing ^d	0.046
EPS FOAM CORE PANEL EXTERIOR WALLS			R-23	3.5 ^e	Conventional framing	0.046
Insulation	Type	U-Factor	R-23	5 ^e	Conventional framing	0.042
R-14.88	4 1/2" EPS foam core panel	0.059	R-23	7 ^e	Conventional framing	0.038
R-22.58	6 1/4" EPS foam core panel	0.040	R-23	3.5 ^e	Advanced framing ^d	0.043
R-29.31	8 1/4" EPS foam core panel	0.031	R-23	5 ^e	Advanced framing ^d	0.040
R-23			R-23	7 ^e	Advanced framing ^d	0.036
BELOW GRADE WALLS						
Insulation	Type	C-Factor				
R-10 c.i.	R-10 continuous insulation	0.085				
R-15 c.i.	R-15 continuous insulation	0.063				
R-13	R-13 cavity and air space	0.080				
R-21	R-21 cavity and air space	0.063				

For SI: 1 inch = 25.4 mm.

- U-factors are for wood-framed construction. U-factors for other assemblies, which include steel framing, brick or other masonry, stucco, etc., shall be calculated using standard ASHRAE *Handbook of Fundamentals* procedures or [ASHRAE 90.1 Appendix A](#).
- Intermediate framing consists of wall studs placed at a minimum 16 inches on center with insulated headers. Voids in headers 1 inch to 2 inches in thickness shall be insulated with rigid insulation having a minimum R-value of 4 per 1-inch thickness. Voids in headers greater than 2 inches in depth shall be insulated to a minimum level of R-10.
- Advanced framing construction for ceilings as defined in Section N1104.6.
- Advanced framing construction for walls as defined in Section N1104.5.1
- Insulation sheathing shall be rigid insulation material, installed continuously over entire exterior or interior of wall (excluding partition walls).
- F-factor is heat loss coefficient in Btu/ h × ft² × °F per lineal foot of concrete slab perimeter for 24 inches below grade.

N1104.2.6 Below-grade exterior insulation. Below-grade exterior insulation shall meet the following conditions:

1. The insulation shall be a material that is *approved* for below-grade applications in wet environments.
2. Insulation shall be installed from the top of the footing to the top of the concrete basement wall.
3. Insulation shall be adequately protected from the elements (ultraviolet and mechanical) in accordance with manufacturer's specifications.
4. The top of the insulation shall be installed in a manner to allow water runoff and prevent pooling.

N1104.2.7 Recessed lighting fixtures. Recessed lighting fixtures installed within the building thermal envelope shall meet one of the following requirements:

1. Type IC-rated, manufactured with no penetrations between the inside of the recessed fixture and ceiling cavity, and the annular space between the ceiling cutout and lighting fixture shall be sealed.
2. Type IC-rated in accordance with ASTM E283 with not more than 2.0 cubic feet per minute (cfm) (0.944 L/s) air movement from the *conditioned space* to the ceiling cavity at 1.57 psi (10 825 Pa) pressure difference shall be labeled, and the annular space between the ceiling cutout and lighting fixture shall be sealed.
3. Type IC-rated installed inside a sealed box constructed from a minimum 0.5-inch-thick (12.7 mm) gypsum wallboard or constructed from a preformed polymeric vapor retarder or other air tight assembly manufactured for this purpose.

N1104.2.8 Doors and pull-down stairs to unconditioned spaces. Service doors between unconditioned and *conditioned spaces* shall meet the thermal requirements of Sections N1104.2.8.1 and N1104.2.8.2.

N1104.2.8.1 Vertical doors. *U*-factors for vertical doors providing access from conditioned to unconditioned spaces shall comply with the exterior door provisions of Table N1101.1(1).

N1104.2.8.2 Pull-down stairs. Horizontal pull-down stair-type access hatches in ceiling assemblies that provide access from conditioned to unconditioned spaces shall have a maximum average *U*-factor of $U-0.10$ or an *R*-value of not less than $R-10$, have a net area of the framed opening not exceeding 13.5 square feet (1.25 m²), and have the perimeter of the hatch weatherstripped.

N1104.3 Exterior doors. Doors shall be tested [and labeled](#) according to the requirements of Section N1104.4. When calculating the energy performance of the exterior envelope, the area of doors shall be the actual unit size. [Doors shall meet the air leakage requirements of Section N1104.8.](#)

Exceptions:

1. Unglazed doors that are not tested according to the requirements of Section N1104.3 shall be assigned a default *U*-value of 0.54.
2. Sliding glass doors and swinging glass doors shall meet the specifications for windows and shall be treated as such.

~~3. Doors that incorporate glazed areas more than 2.5 square feet (0.23 m²) in area shall be considered exterior doors with greater than or equal to 2.5 square feet (0.23 m²) glazing.~~

N1104.4 Windows. All windows installed in Oregon shall meet the requirements of Part III, Fenestration Standard, of this chapter.

1. Decorative or unique architectural feature glazing not exceeding 1 percent of the heated space floor area is exempt from thermal performance requirements and does not need to be included in Table N1104.1(1) calculations.
2. Glass block assemblies may use a *U*-factor of 0.51.
3. The *U*-factor for windows may be a weighted average of total window area where all other building thermal envelope measures are in compliance with performance requirements specified in this code. This calculation shall be provided to the building official and the windows that are less than the required prescriptive compliance shall be identified on the plans.

N1104.4.1 Thermal performance labeling. All fenestrations shall have labels. The labels shall be a National Fenestration Rating Council (NFRC) certified product or a state-approved label for windows produced in low volume. All labeling shall conform to the following requirements:

1. Be imprinted and not handwritten.
2. Face the interior of the room.
3. List the *U*-factor.
4. Be attached to the window until the building inspector inspects and verifies the labeling.

Exceptions:

1. Labeling is not required for decorative or unique architectural feature glazing not exceeding 1 percent of the heated space floor area.
2. Portions of labels for windows produced in low volume may be handwritten.

N1104.4.2 Combined products. Where different window types are combined, mulled together by the manufacturer or manufactured to fit a framed rough opening, a single label may be used.

Exception: A solarium shall have one label providing a description of each of the glazed surfaces, such as the front, overhead and each side.

~~**N1104.4.3 Air leakage requirements.** Air infiltration rates for all exterior windows, swinging doors and sliding glass doors shall be certified in accordance with ASTM E283, Standard Test Methods for Rate of Air Leakage through Exterior Windows, Curtain Walls and Doors Under Specified Pressure Differences Across the Specimen. Tests shall be conducted at a differential pressure of 1.57 pounds per square foot (75 Pa) [equivalent to 25 mph (40 km/h) wind condition].~~

- ~~1. Windows 0.37 cubic feet per minute (cfm) per foot (0.17 L/s per m) of sash crack.~~
- ~~2. Swinging doors 0.37 cfm per square foot (0.17 L/s per m²) of door area.~~
- ~~3. Sliding doors 0.37 cfm per square foot (0.17 L/s per m²) of door area.~~

~~**Exception:** Site-built windows.~~

N1104.4.3 Fenestration air leakage. Windows, skylights and sliding glass doors shall have an air infiltration rate of not greater than 0.3 cfm per square foot (1.5 L/s/m²), and for swinging doors, not greater than 0.5 cfm per square foot (2.6 L/s/m²) when tested in accordance with NFRC 400-2020 or AAMA/WDMA/CSA 101/I.S.2/A440-17 by an accredited, independent laboratory and listed and labeled by the manufacturer.

Exception: Site-built windows, skylights and doors.

N1104.4.4 Alterations. New windows shall have a maximum *U*-factor as required by Table N1101.1(1).

Exceptions:

1. Decorative or unique architectural feature glazing not exceeding 1 percent of the heated space floor area may be exempt from thermal performance requirements and Table N1104.1(1) calculations.
2. Where necessary to retain architectural consistency with remaining windows in the building, new windows shall have a maximum *U*-value of 0.65.

N1104.5 Walls.

N1104.5.1 Advanced framing for walls. Advanced framing for walls is an optional construction method. Advanced framing, when used to qualify a design under the requirements of Table N1104.1(1), shall meet the following requirements:

1. Walls. Walls shall be framed with 2 × studs at 24 inches (610 mm) on center and shall include the following, as detailed in Items 2 and 3.
2. Corners and intersections. Exterior wall and ceiling corners shall be fully insulated through the use of three-stud corners configured to allow full insulation into the corner, or two-stud corners and drywall backup clips or other *approved* technique. Intersections of interior partition walls with exterior walls shall be fully insulated through the use of single backer boards, mid-height blocking with drywall clips or other *approved* technique.
3. Headers. Voids in headers 1 inch (25.4 mm) to 2 inches (51 mm) in thickness shall be insulated with insulation

that has a value of R-4 or greater per 1-inch (25.4 mm) thickness. Voids in headers greater than 2 inches (51 mm) in depth shall be insulated to a minimum level of R-10. ~~Nonstructural headers (such as in gable end walls) shall be eliminated and replaced with insulation to achieve thermal performance levels equivalent to the surrounding area.~~

N1104.5.2 Intermediate framing for walls. Intermediate framing for walls is an optional construction method. Intermediate framing, when used to achieve improved wall performance under the requirements of Table 1101.1(1) or Table N1104.1(2), shall meet the following requirements:

1. Walls. Walls shall be framed with 2 × studs at 16 inches (406 mm) on center and shall include the following, as detailed in Items 2 and 3.
2. Corners and intersections. Exterior wall and ceiling corners shall be fully insulated through the use of three-stud corners configured to allow full insulation into the corner, or two-stud corners and drywall backup clips or other approved technique. Intersections of interior partition walls with exterior walls shall be fully insulated through the use of single backer boards, mid-height blocking with drywall clips or other *approved* technique.
3. Headers. Voids in headers 1 inch (25.4 mm) to 2 inches (51 mm) in thickness shall be insulated with insulation that has a value of R-4 or greater per 1-inch (25.4 mm) thickness. Voids in headers greater than 2 inches (51 mm) in depth shall be insulated to a minimum level of R-10. ~~Nonstructural headers (such as in gable end walls) shall be eliminated and replaced with insulation to achieve thermal performance levels equivalent to the surrounding area.~~

N1104.5.3 Below-grade walls. Walls enclosing heated spaces below grade shall be insulated from the bottom of the above-grade subfloor downward to the top of the below-grade finished floor.

N1104.6 Roof/ceiling: advanced framing for ceilings. Advanced framing for ceilings is an optional construction method. Advanced framing, when used to qualify a design under the requirements of Section N1104.1, shall meet the following requirements.

Framing techniques shall be used in attics and ceilings to provide full insulating value to the outside of exterior walls. This shall be accomplished through the use of extra-depth or oversized trusses, double rafters, special insulation components installed at the edge of the wall, or other *approved* combinations of framing and insulation. The entire surface of the exterior ceiling shall be insulated to the required value, including attic hatches, structural members, electrical fixtures (where allowed by the code) and plumbing penetrations.

N1104.7 Slab-on-grade floors. For slab-on-grade floors, the perimeter of the floor shall be insulated.

The insulation shall extend downward from the top of the slab for a minimum of 24 inches (610 mm) or downward to the

bottom of the slab, then horizontally beneath the slab for a minimum total distance of 24 inches (610 mm). [The minimum total distance of 24 inches \(610 mm\) may be a combination of the horizontal and vertical planes. If a horizontal plane is used on the exterior of the slab, it shall be a minimum of 12 inches \(305 mm\) below finished grade.](#)

Exception: For monolithic slabs, the insulation shall extend downward from the top of the slab to the bottom of the thickened edge.

N1104.7.1 Slab-on-grade floors with hydronic heat. For slab-on-grade floors that incorporate hydronic heating, in addition to perimeter insulation, the entire underside of the slab shall be insulated to R-10.

N1104.8 Air leakage. The building thermal envelope shall be constructed to limit air leakage in accordance with this section.

N1104.8.1 Air barriers. A continuous air barrier shall be installed and fully aligned with the building thermal envelope on every vertical portion of air-permeable insulation and on the warm side of horizontal, air-permeable insulation. Air-permeable insulation shall not be used as a sealing material.

Exception: Unvented attics, continuous insulation walls and similar conditions where an impermeable insulation layer forms an air barrier.

N1104.8.2 Sealing required. Exterior joints around window and door frames; between wall cavities and window or door frames; between walls and foundation; between walls and roof; between wall panels; at penetrations or utility services through walls, floors and roofs; and all other openings in the exterior envelope shall be sealed in a manner *approved* by the *building official*. Sealing for the purpose of creating a continuous air barrier shall be in accordance with the applicable requirements of Table N1104.8, or the *dwelling* shall be tested to demonstrate a blower door result not greater than [3.25](#) ACH50.

N1104.8.2.1 Top plate sealing. At all walls in contact with vented attics, the wall covering (gypsum board or other) shall be sealed to the top plate with caulk, sealant, gasket or other *approved* material.

N1104.9 Moisture control. To ensure the effectiveness of insulation materials and reduce the hazard of decay and other degradation due to condensation within the structure, moisture-control measures shall be included in all buildings and structures or portions thereof regulated by this chapter.

N1104.9.1 Vapor retarders. Vapor retarders shall be installed in accordance with Section R318.

**TABLE N1104.8
AIR BARRIER INSTALLATION AND AIR SEALING REQUIREMENTS**

(Errata issued April 2024)

COMPONENT	AIR BARRIER CRITERIA
General requirements	A continuous air barrier shall be installed in alignment with the building thermal envelope.
	Breaks or joints in the air barrier shall be sealed.
Ceiling/attic	The air barrier in any dropped ceiling or soffit shall be aligned with the insulation and any gaps in the air barrier shall be sealed.
	Access openings, drop-down stairs, or knee wall doors to unconditioned attic spaces shall be gasketed and sealed.
Walls	The junction of the foundation and sill plate shall be sealed.
	The junction of the top plate and the top of interior walls shall be sealed between wall cavities and windows or door frames.
	All penetrations or utility services through the top and bottom plates shall be sealed.
	Knee walls shall be sealed.
Windows, skylights and doors	The annular space between framing and skylights, and the jambs of windows and doors shall be air sealed. Framing cavities around windows, skylights and doors shall contain continuous insulation or be installed per the fenestration manufacturer's instructions.
Rim/band joists	Rim/band joists shall be a part of the thermal envelope and have a continuous air barrier.
Floors Including cantilevered floors and floors above garages	The air barrier shall be installed at any exposed edge of insulation.
Crawl space walls	Exposed earth in unvented crawl spaces shall be covered with a Class I vapor retarder with overlapping joints taped.
Shafts, penetrations	Duct shafts, utility penetrations and flue shafts opening to exterior or unconditioned space shall be sealed.
Garage separation	Air sealing shall be provided between the garage and conditioned spaces.
Recessed lighting	Recessed light fixtures installed in the building thermal envelope shall be sealed to the finished surface.
Shower/tub on exterior walls	The air barrier installed at exterior walls adjacent to showers and tubs shall separate the wall from the shower or tub.
Electrical/phone box on exterior walls	The air barrier shall be installed behind electrical and communication boxes. Alternatively, air-sealed boxes shall be installed.
HVAC register boots	HVAC supply and return register boots that penetrate the building thermal envelope shall be sealed to the subfloor, wall covering or ceiling penetrated by the boot.

N1104.9.2 Ground cover. A ground cover shall be installed in the crawl space for both new and existing buildings when insulation is installed. Ground cover shall be installed in accordance with Chapter 4.

SECTION N1105 HEATING, VENTILATING AND AIR-CONDITIONING SYSTEMS

N1105.1 General. This section provides minimum requirements for heating, ventilating and air-conditioning systems.

N1105.2 Insulation of ducts. All new duct systems or new portions of duct systems exposed to unconditioned spaces, and buried ductwork within insulation that meets the exception to Section N1105.3, shall be insulated to minimum R-8.

Exceptions:

1. The replacement or addition of a furnace, air conditioner or heat pump shall not require existing ducts to be insulated to current code.
2. Exhaust and intake ductwork.

(Errata issued April 2024)

N1105.3 Installation of ducts and air handling equipment.

For new construction and additions, all new duct systems and air handling equipment and appliances shall be located fully within the *building thermal envelope*.

Exceptions:

1. Ventilation intake ductwork and exhaust ductwork.
2. Up to 10 feet (3048 mm) of HVAC ductwork.
3. Where two measures are selected for compliance from Table N1101.1(2) and HVAC supply and return ductwork is installed in accordance with either Section N1105.3.1, N1105.3.2 or N1105.3.3.

N1105.3.1 Deeply buried duct in attic. Ducts deeply buried in attic insulation shall be in accordance with all of the following when using Section N1105.3, Exception 3:

1. Insulation shall be installed to fill gaps and voids between the duct and the ceiling, and a minimum of R-19 insulation shall be installed above the duct between the duct and unconditioned attic.
2. All ductwork in the attic shall be insulated to R-8.
3. Insulation depth marker flags shall be installed on the ducts every 10 feet (3048 mm) or as approved by the building official.

Exception: HVAC ductwork shall be permitted to be located outside of the *building thermal envelope* where the duct is insulated to a minimum of R-27 with a Class II or III vapor retarder.

N1105.3.2 Ducts in an unvented crawlspace outside the building thermal envelope. Ducts located in an unvented crawlspace outside the *building thermal envelope* shall be in accordance with all of the following when using Section N1105.3, Exception 3:

1. In addition to meeting Section R408.3, all seams of the vapor barrier shall overlap a minimum of 12 inches (305 mm) and be sealed with tape or other approved method.
2. All ductwork in the crawlspace shall be insulated to R-8.
3. The floor between the crawlspace and the dwelling shall be insulated with minimum R-30.

N1105.3.3 Deeply buried duct in vented crawlspace. Ducts deeply buried in crawlspace insulation shall be in accordance all of the following when using Section N1105.3, Exception 3:

1. Insulation shall be installed to fill gaps and voids between the duct and the floor above, and a minimum of R-19 insulation shall be installed below the duct and between the duct and unconditioned crawlspace.
2. All ductwork in the crawlspace shall be insulated to R-8.
3. The floor between the crawlspace and the dwelling shall be insulated with minimum R-30.

Exception: HVAC ductwork shall be permitted to be located outside of the *building thermal envelope* where the duct is insulated to a minimum of R-27 with a Class II or III vapor retarder.

N1105.4 HVAC controls. All heating, ventilating and air-conditioning systems shall be provided controls as specified herein.

N1105.4.1 Temperature controls. Each heating, ventilating and *air-conditioning system* shall be provided with at least one thermostat for the regulation of temperature. Each thermostat shall be capable of being set from 55°F to 75°F (13°C to 24°C) where used to control heating only and from 70°F to 85°F (21°C to 29°C) where used to control cooling only. Where used to control both heating and cooling, it shall be capable of being set from 55°F to 85°F (13°C to 29°C) and shall be capable of operating the system heating and cooling in sequence. It shall be capable of providing a temperature range of at least 5°F 2.8°C) within which the supply of heating and cooling energy to the zone is shut off or reduced to a minimum.

N1105.4.1.1 Setback and shutoff. The thermostat, ~~or an alternative means such as switch or clock,~~ shall provide a readily accessible ~~manual or~~ automatic means for reducing the energy required for heating and cooling during periods of nonuse or reduced need.

Exceptions:

1. Where it can be shown that setback or shutdown will not result in a decrease in overall building energy.
2. Equipment with full-load demand of 2 kilowatts (6824 Btu/h) or less may be controlled by readily accessible off-hour controls.

Lowering thermostat setpoints to reduce energy consumption of the heating system shall not cause energy to be expended to reach the reduced setting.

N1105.4.1.2 Smart thermostat. For new construction, the thermostat shall meet ENERGY STAR Smart Thermostat criteria with minimum control feature of either integral occupancy sensing or geofencing or *approved* equivalent.

Exception: Individual heating or cooling units with heating capacity of 2 kilowatts (6824 Btu/h) or less or with cooling capacity of less than 5.3 kilowatts (18,000 Btu/h).

N1105.4.1.3 Heat pump controls. ~~All heat pump system thermostats shall be capable of manual setback and limiting the use of supplemental heat during warm-up periods. Heat pumps having supplementary electric-resistance heat shall have controls that, except during defrost, prevent supplemental heat operation when the heat pump compressor can meet the heating load.~~

~~**N1105.4.1.1 Outdoor thermostat required.** An outdoor thermostat or factory installed temperature sensor with electronic controls shall be used to lock out supplemental heat based on outdoor air temperature. The lock-out temperature shall be set at 4°F (40°C). There shall be no compressor lock-out temperature.~~

N1105.4.2 Humidity. If a heating, ventilating and *air-conditioning system* is equipped with a means for adding moisture to maintain specific selected relative humidity in spaces or zones, a humidistat shall be provided. This device shall be capable of being set to prevent new energy from being used to produce space relative humidity above 30 percent. Where a humidistat is used in a heating, ventilating and air-conditioning system for controlling moisture removal to maintain specific selected relative humidity in spaces or zones, it shall be capable of being set to prevent new energy from being used to produce a space-relative humidity below 60 percent.

N1105.4.3 Temperature zoning. Each separate heating, ventilating and *air-conditioning system* shall be provided with at least one thermostat for regulation of space temperature. In addition, a readily accessible manual or automatic means shall be provided to partially restrict or shut off the heating or cooling input to each zone or floor, excluding unheated or noncooled basements and garages.

N1105.5 Outside combustion air. See Section R1006 for required outside combustion air for masonry fireplaces, factory-built fireplace and factory-built stoves.

N1105.6 Ventilation fan efficiency. Bathroom exhaust fans and outdoor ventilation air supply fans shall be ENERGY STAR certified. ~~A fan that is the air mover for a heating or cooling system that serves an individual dwelling unit shall not be used to provide outdoor air except where its fan efficacy is not less than 1.2 cubic feet per minute (cfm) (0.566 L/s) of outdoor airflow per watt when there is no demand for heating or cooling.~~

N1105.7 Furnace fan efficiency. New central furnaces shall have electronically commutated fan motors with a fan efficiency rating meeting 10 CFR 430.32(y).

SECTION N1106 PIPING INSULATION

N1106.1 Mechanical system piping insulation. Mechanical system piping capable of carrying fluids above 105°F (40.5°C) or below 55°F (13°C) shall be insulated to a minimum of R-3.

N1106.2 Domestic and service hot water systems. Domestic hot water piping shall be insulated to a minimum of R-3 at the following locations:

1. Pipe not located fully within the conditioned space outside the building thermal envelope.
2. The first 8 feet (2438 mm) of pipe into and out of a water heater.
3. Recirculating water piping.

N1106.3 Protection of piping insulation. Piping insulation exposed to weather shall be protected from damage, including that caused by sunlight, moisture, equipment maintenance and wind. The protection shall provide shielding from solar radiation that can cause degradation of the material. Adhesive tape shall not be used for protection system.

SECTION N1107 LIGHTING AND POWER

N1107.1 General. The provisions of this section apply to power and lighting equipment, related controls and electric circuits serving all conditioned and unconditioned interior floor space and exterior building facades of all dwelling units and guest rooms within residential buildings and structures, or portions thereof.

N1107.2 High-efficiency interior lighting. All permanently installed lighting fixtures shall be *high-efficiency light sources*.

The building official shall be notified in writing at the final inspection that the permanently installed lighting fixtures have met this requirement.

Exception: Two permanently installed lighting fixtures are not required to be *high-efficiency light sources* when controlled by a dimmer or automatic control.

N1107.3 High-efficiency exterior lighting. All exterior lighting fixtures affixed to the exterior of the building shall be *high-efficiency light sources*.

Exception: Two permanently installed lighting fixtures are not required to be *high-efficiency light sources* when controlled by automatic control.

SECTION N1108 PLUMBING FIXTURE EFFICIENCY

N1108.1 General. This section shall apply to plumbing fixture efficiency.

N1108.1.1 Fixture efficiency. Fixture efficiency shall be per the *Plumbing Code*.

PART II—ALTERNATIVE SYSTEMS ANALYSIS

SECTION NA1109 ENERGY RATING INDEX (ERI) COMPLIANCE

NA1109.1 Scope. This section establishes criteria for compliance using an Energy Rating Index (ERI) analysis.

NA1109.2 ERI compliance. Compliance based on the ERI requires that the *rated design* meets the *building thermal envelope* requirements in Section N1104 and shall be shown to have a score less than or equal to the values in Table NA1109.1 when compared to the *ERI reference design* determined in accordance with RESNET/ICC 301, excluding onsite power production (OPP).

**TABLE NA1109.1
MAXIMUM ENERGY RATING INDEX**

CLIMATE ZONE	ENERGY RATING INDEX (Not including OPP)
4C	54
5C	55

NA1109.3 Verification by approved agency. Verification of compliance with Section NA1109 as outlined in Section NA1109.1 shall be completed by the *building official* or an approved third-party inspection agency in accordance with Section R109.2.

NA1109.4 Documentation. Documentation of the software used to determine the ERI and the parameters for the *residential building* shall be in accordance with Sections NA1109.4.1 through NA1109.4.4.

NA1109.4.1 Compliance software tools. Software tools used for determining ERI shall be Approved Software Rating Tools in accordance with RESNET/ICC 301.

NA1109.4.2 Compliance report. Compliance software tools shall generate a report that documents that the home and the ERI score of the *rated design* complies with Section NA1109.1. Compliance documentation shall be created for the proposed design and shall be submitted with the application for the building *permit*. Confirmed compliance documents of the built *dwelling unit* shall be created and submitted to the *building official* for review before a certificate of occupancy is issued. Compliance reports shall include information in accordance with Sections NA1109.4.2.1 and NA1109.4.2.2.

NA1109.4.2.1 Proposed compliance report for permit application. Compliance reports submitted with the application for a building *permit* shall include the following:

1. Building street address, or other *building site* identification.
2. Declare ERI on title page and building plans.
3. The name of the individual performing the analysis and generating the compliance report.
4. The name and version of the compliance software tool.
5. Documentation of all inputs entered into the software used to produce the results for the reference design and/or the rated home.

6. A certificate indicating that the proposed design has an ERI less than or equal to the appropriate score indicated in Table NA1109.1 when compared to the *ERI reference design*. The certificate shall document the building component energy specifications that are included in the calculation, including: component level insulation *R*-values or *U*-factors; assumed duct system and building envelope air leakage testing results; and the type and rated efficiencies of proposed heating, cooling, mechanical ventilation, and service water-heating equipment to be installed. If on-site renewable energy systems will be installed, the certificate shall report the type and production size of the proposed system.

7. When a site-specific report is not generated, the proposed design shall be based on the worst-case orientation and configuration of the rated home.

NA1109.4.2.2 Confirmed compliance report for a certificate of occupancy. A confirmed compliance report submitted for obtaining the certificate of occupancy shall be made site and address specific and include the following:

1. Building street address or other *building site* identification.
2. Declaration of ERI on title page and on building plans.
3. The name of the individual performing the analysis and generating the report.
4. The name and version of the compliance software tool.
5. Documentation of all inputs entered into the software used to produce the results for the reference design and/or the rated home.
6. A final confirmed certificate indicating that the confirmed *rated design* of the built home complies with Section NA1109.1. The certificate shall report the energy features that were confirmed to be in the home, including: component-level insulation *R*-values or *U*-factors; results from any required duct system and building envelope air leakage testing; and the type and rated efficiencies of the heating, cooling, mechanical ventilation, and service water-heating equipment installed. Where on-site renewable energy systems have been installed on or in the home, the certificate shall report the type and production size of the installed system.

NA1109.4.3 Additional documentation. The *building official* shall be permitted to require the following documents:

1. Documentation of the building component characteristics of the *ERI reference design*.
2. A certification signed by the builder providing the building component characteristics of the *rated design*.
3. Documentation of the actual values used in the software calculations for the *rated design*.

NA1109.4.4 Input values. Where calculations require input values not specified by Sections N1101, N1104, N1105, N1106, N1107 and N1108, those input values shall be taken from RESNET/ICC 301.

PART III—FENESTRATION STANDARD

SECTION NF1110 SCOPE

NF1110.1 General. All windows installed in Oregon shall meet the requirements of this section.

SECTION NF1111 ALTERATIONS

NF1111.1 Windows. Windows shall be tested and labeled in accordance with Section N1104.4.

The following information is reprinted for the reader's convenience:

N1104.4 Windows. All windows installed in Oregon shall meet the requirements of Part III, Fenestration Standard.

1. Decorative or unique architectural feature glazing not exceeding 1 percent of the heated space floor area is exempt from thermal performance requirements and does not need to be included in Table N1104.1(1) thermal performance calculations.
2. Glass block assemblies may use a *U*-factor of 0.51.

The *U*-factor for windows may be a weighted average of total window area when all other building envelope measures comply with the performance requirements specified in this code. This calculation shall be provided to the *building official* and the windows that are less than required for prescriptive compliance shall be identified on the plans.

SECTION NF1112 DEFINITIONS

NF1112.1 General. For purposes of this section the following definitions are provided:

ALUMINUM WITH VINYL. Fenestration framing material consisting of a composite of both aluminum and vinyl framing constructed in a manner where the aluminum framing is provided a complete thermal break by the vinyl framing.

MANUFACTURER. Producer of windows, assembles window components or does both. A “manufacturer” includes its subsidiaries, divisions and all other companies under common control or ownership.

SUNROOM/SOLARIUM. A one-story structure attached to a dwelling with a glazing area in excess of 40 percent of the gross area of that structure's exterior walls and roof.

WINDOWS PRODUCED IN LOW VOLUME. A manufacturer's product installed in Oregon during a calendar year that does not exceed: 750 windows, 500 glazed doors, 1,000 *skylights* covered in Section NF1114.2 and 25 complete sunrooms/solariums.

SECTION NF1113 INSULATING GLASS CERTIFICATION

NF1113.1 General. Sealed [insulating glass units](#) shall conform to [ASTM E2190 and shall be certified by an accredited insulating glass unit certification program](#).

SECTION NF1114 WINDOW THERMAL PERFORMANCE DESIGNATION FOR NEW BUILDINGS AND ADDITIONS

The requirements of this section are not intended to waive or supersede any window thermal performance requirements under state or federal laws.

NF1114.1 Manufactured windows. *U*-factors for manufactured fenestration products (windows, skylights and doors) shall be determined in accordance with the National Fenestration Rating Council (NFRC) 100 2001 Procedure for Determining Fenestration Product *U*-Factors. The *U*-factors shall be labeled and certified in accordance with the NFRC Product Certification.

NF1114.2 Windows products exempt from testing. The following products are exempt from thermal performance testing as specified in Section NF1114.1.

1. Windows produced in low volume.
2. Glazing not exceeding 1 percent of the heated space floor area.
3. Solariums and sunrooms.
4. *Skylights* constituting no more than 10 percent of total glazing in a residential building.
5. *Skylights* constructed with wood, thermal break aluminum or aluminum with vinyl frames with a glazing configuration of either: a minimum 0.5-inch (12.7 mm) space between the panes and low-e glass; or triple-layered acrylic.

NF1114.2.1 Thermal performance of exempted products. The thermal performance of window products exempted from testing shall be determined by the following procedures:

1. Windows produced in low volume are assigned default *U*-factors as specified in Section NF1114.3, Item 1.
2. Glazed doors produced in low volume are assigned default *U*-factors as specified in Section NF1114.3, Item 2.
3. *Skylights* produced in low volume are assigned default *U*-factors as specified in Section NF1114.3, Item 3.
4. *Skylights* constituting no more than 10 percent of total glazing in a residential building that are exempt from testing are assigned default *U*-factors as specified in Section NF1114.3, Item 3.
5. Vertical and overhead glazing contained in sunrooms/solariums are assigned default *U*-factors as specified in Section NF1114.3, Items 1, 2 and 4.
6. *Skylights* specified in Section NF1114.2, Item 5 shall be assigned a default *U*-factor of 0.50.

NF1114.3 Thermal performance validation for windows produced in low volume or site-built. Windows, glazed doors, *skylights* and sunroom/solariums produced in low volume and meeting the requirements of this subsection may validate default *U*-factors:

1. By using Table NF1114.3(1) for windows.
2. By using Table NF1114.3(2) for glazed doors.

3. By using Table NF1114.3(1) for *skylights* based on an overall *U*-factor of U-0.50.
4. By using Table NF1114.3(1) for overhead glazing installed in sunrooms/solariums based on an overall *U*-factor of U-0.35.

SECTION NF1115 THERMAL PERFORMANCE LABELING

The requirements of this section are not intended to waive or supersede any window label or disclosure requirements under state or federal laws.

NF1115.1 Labels. Labels shall be either:

1. National Fenestration Rating Council (NFRC) certified product; or
2. State-approved labels.

Labeling is not required for glazing not exceeding one percent of the heated space floor area and is exempt from Table N1104.1(1) thermal performance calculations.

NF1115.2 Label description. All windows shall have state-approved labeling except as provided in Section NF1115.1, Item 1.

Exceptions:

1. Labeling is not required for glazing not exceeding 1 percent of the heated space floor area.
2. Portions of labels for windows produced in low volume may be handwritten.

NF1115.2.1 Windows produced in low volume labels. Labels for windows produced in low volume under NF1112(1), due to its frame and glazing configuration shall comply with all of the following:

1. Specify window components.
2. Show the allowed *U*-factor in the appropriate location.
3. Show a production count number that does not exceed the maximums established in NF1112(1).
4. Imprint “[Manufacturer’s name] certifies the attached window is constructed in a manner to obtain the specified *U*-factor” or “[Manufacturer’s name] certifies the attached skylight complies with the criteria specified in the Oregon building codes.”
5. Be imprinted, not handwritten.
6. Face the interior of the room.
7. Remain attached to the window until the building inspector inspects and verifies the labeling.

NF1115.3 Labels for skylights exempted from thermal performance standards. Labels for *skylights* exempt from thermal performance standards under Section NF1114.2, Item 5, because of its frame and glazing configuration shall comply with all of the following:

1. Specify *skylight* components.
2. State “U-0.50 Default *U*-factor.”
3. State “Limited Production Skylight Compliance *U*-factor Label” and “Maximum Allowable Skylight Area Shall Not Exceed Two Percent of the Heated Space Floor Area.”

4. Show a production count number that does not exceed the maximums established in Section NF1112.1.
5. Imprint “[Manufacturer’s name] certifies the attached skylight complies with the criteria specified in the Oregon building codes.”
6. Contain the statement, “This skylight is not required to be tested or evaluated for thermal performance.”
7. State “EXEMPT” in 0.75-inch (20 mm) high letters.
8. Specify “Issued [Date of issue].”
9. Contain the statement, “Under ORS 455.525(4), this skylight is deemed to comply with Oregon’s thermal performance standards regardless of *U*-factor.”

NF1115.4 Labels for sunrooms/solariums produced in low volume or exempted from testing. Labels for solariums and sunrooms produced in low volume or with 0.5-inch (12.7 mm) airspace between the glazing shall comply with all of the following:

1. Specify the components for each of the glazed surfaces, such as the front, overhead, and each side.
2. Show a production count number that does not exceed the maximums established in Section NF1112.
3. Show the *U*-factor determined by Section NF1114.2.1, Item 5 or NF1114.3, Item 4 for each of the glazed surfaces.
4. Imprint “[Manufacturer’s name] certifies the components of this sunroom or solarium are constructed in a manner to obtain the specified *U*-factor.”
5. Have one label providing a description of each of the glazed surfaces.

NF1115.5 Labels for skylights exempt from testing. Labels for skylights that are exempt from testing in accordance with Section NF1114.2(4) shall comply with all of the following:

1. Specify *skylight* components.
2. State “Calculated *U*-factor Skylight Compliance Label.”
3. State *U*-factor determined by Section NF1114.2.1, Item 4.
4. Show a production count number that does not exceed the maximums established in Section NF1112.

NF1115.6 Combined products. When different window types are combined, mulled together by the manufacturer or manufactured to fit a framed rough opening, a single label may be used.

Exception: A *skylight*/solarium shall have one label providing a description of each of the glazed surfaces, such as the front, overhead, and each side.

NF1115.7 Label distribution. Labels provided under Section NF1114.2 shall be designed by the division and sold by persons authorized by the agency and shall not be sold in lots exceeding the maximums for each window type per manufacturer during any calendar year.

SECTION NF1116 AIR LEAKAGE REQUIREMENTS

NF1116.1 General. Windows shall comply with the air leakage requirements of Section N1104.8.

Exception: Site-built windows.

TABLE NF1114.3(1)
APPROVED WINDOW DEFAULT U-VALUES^{a, b}

DESCRIPTION ^{c, d, e, f, g} (inches)	FRAME TYPE ^h		
	ALUMINUM THERMAL BREAK ⁱ	WOOD/VINYL	ALUMINUM CLAD WOOD/REINFORCED VINYL ^j
Double, Clear 1/4	N/A	0.56	0.59
Double, Clear 1/4 + argon	0.63	0.53	0.56
Double, Low-e 4, 1/4	0.61	0.52	0.54
Double, Low-e 2, 1/4	0.58	0.49	0.51
Double, Low-e 1, 1/4	0.55	0.47	0.49
Double, Low-e 4, 1/4 + argon	0.55	0.47	0.49
Double, Low-e 2, 1/4 + argon	0.52	0.43	0.46
Double, Low-e 1, 1/4 + argon	0.50	0.41	0.43
Double, Clear 3/8	0.63	0.54	0.57
Double, Clear 3/8 + argon	0.60	0.51	0.54
Double, Low-e 4, 3/8	0.57	0.48	0.51
Double, Low-e 2, 3/8	0.54	0.45	0.48
Double, Low-e 1, 3/8	0.51	0.43	0.46
Double, Low-e 4, 3/8 + argon	0.53	0.44	0.47
Double, Low-e 2, 3/8 + argon	0.49	0.41	0.44
Double, Low-e 1, 3/8 + argon	0.47	0.39	0.41
Double, Clear 1/2	0.60	0.50	0.54
Double, Clear 1/2 + argon	0.58	0.48	0.51
Double, Low-e 4, 1/2	0.53	0.44	0.47
Double, Low-e 2, 1/2	0.50	0.41	0.44
Double, Low-e 1, 1/2	0.47	0.39	0.42
Double, Low-e 4, 1/2 + argon	0.50	0.42	0.44
Double, Low-e 2, 1/2 + argon	0.46	0.37	0.40
Double, Low-e 1, 1/2 + argon	0.43	0.35	0.38
Triple, Clear 1/4	0.52	0.42	0.44
Triple, Clear 1/4 + argon	0.49	0.39	0.42
Triple, Low-e 4, 1/4	0.50	0.40	0.40
Triple, Low-e 2, 1/4	0.48	0.39	0.41
Triple, Low-e 1, 1/4	0.47	0.38	0.40
Triple, Low-e 4, 1/4 + argon	0.46	0.37	0.39
Triple, Low-e 2, 1/4 + argon	0.43	0.34	0.37
Triple, Low-e 1, 1/4 + argon	0.42	0.34	0.36
Triple, Clear 1/2	0.46	0.37	0.40
Triple, Clear 1/2 + argon	0.45	0.36	0.38
Triple, Low-e 4, 1/2	0.43	0.35	0.37
Triple, Low-e 2, 1/2	0.41	0.32	0.35
Triple, Low-e 1, 1/2	0.39	0.31	0.33
Triple, Low-e 4, 1/2 + argon	0.41	0.32	0.35
Triple, Low-e 2, 1/2 + argon	0.38	0.30	0.32
Triple, Low-e 1, 1/2 + argon	0.37	0.29	0.31

For SI: 1 inch = 25.4 mm.

- a. Subtract 0.02 from the listed default *U*-factor for insulated spacers. Insulated spacer material includes fiberglass, wood and butyl or other material with an equivalent *K*-value.
- b. Sunrooms/solariums may subtract 0.03 from the default *U*-factor.
- c. 1/4" = a minimum dead air space of 0.25 inch (6.4 mm) between the panes of glass.
3/8" = a minimum dead air space of 0.375 inch (9.5 mm) between the panes of glass.
1/2" = a minimum dead air space of 0.5 inch (12.7 mm) between the panes of glass.
Products with air spaces different than those listed above shall use the value for the next smaller air space; i.e. 3/4 inch = 1/2-inch *U*-factor, 7/16 inch = 3/8-inch *U*-factor, 5/16 inch = 1/4-inch *U*-factor.
- d. Low-e 4 (emissivity) shall be 0.4 or less.
Low-e 2 (emissivity) shall be 0.2 or less.
Low-e 1 (emissivity) shall be 0.1 or less.
- e. *U*-factors listed for argon shall consist of sealed, gas-filled, insulated units for argon, CO₂, SF₆ and argon/SF₆ mixtures.
The following conversion factor shall apply to Krypton gas-filled units: 1/4-inch (6.4 mm) or greater airspace with Krypton gas fill = 1/2-inch (12.7 mm) airspace with Argon gas-fill.
- f. Dividers placed between glazing: The *U*-factors listed shall be used where the divider has a minimum gap of 1/8 inch (3.2 mm) between the divider and lite of each inside glass surface. Add 0.03 to the listed *U*-factor for True Divided Lite windows.
- g. "Glass block" assemblies may use a *U*-factor of 0.51.
- h. Insulated fiberglass framed products shall use wood/vinyl *U*-factors.

(continued)

TABLE NF1114.3(1)—continued
APPROVED WINDOW DEFAULT U-VALUES^{a,b}

- i. Aluminum Thermal Break = An aluminum thermal break framed window shall incorporate the following minimum design characteristics:
 - 1. The thermal conductivity of the thermal break material shall be not more than 3.6 Btu-in/h × ft² × °F;
 - 2. The thermal break material shall not be less than 0.210 inch; and
 - 3. All metal framing members of the product to interior and exterior air must incorporate a thermal break meeting the criteria in 1 and 2 above.
- j. Aluminum clad wood windows shall use the *U*-factors listed for Aluminum Clad Wood/Reinforced Vinyl windows. Vinyl clad windows shall use the *U*-factors listed for Wood/Vinyl windows. Any vinyl frame window with metal reinforcement in more than one rail shall use the *U*-factors listed for Aluminum Clad Wood Reinforced Vinyl windows.

TABLE NF1114.3(2)
APPROVED GLAZED DOOR DEFAULT U-VALUES^a

DESCRIPTION ^{b, c, d, e} (inches)	DOOR MATERIAL			
	INSULATED ^f	WOOD ^g		
	Full-Lite ^{h, i}	Half-Lite ^{i, k}	Full-Lite ^h	Half-Lite ^j
Double, Clear 1/4	0.39	0.31	0.47	0.42
Double, Clear 1/4 + argon	0.37	0.30	0.45	0.41
Double, Low-e 4, 1/4	0.36	0.30	0.44	0.41
Double, Low-e 2, 1/4	0.35	0.29	0.43	0.40
Double, Low-e 1, 1/4	0.24	0.28	0.41	0.39
Double, Low-e 4, 1/4 + argon	0.33	0.28	0.41	0.39
Double, Low-e 2, 1/4 + argon	0.31	0.26	0.39	0.38
Double, Low-e 1, 1/4 + argon	0.31	0.26	0.38	0.37
Double, Clear 3/8	0.37	0.30	0.45	0.41
Double, Clear 3/8 + argon	0.36	0.29	0.44	0.41
Double, Low-e 4, 3/8	0.34	0.28	0.42	0.40
Double, Low-e 2, 3/8	0.33	0.28	0.41	0.39
Double, Low-e 1, 3/8	0.21	0.26	0.38	0.37
Double, Low-e 4, 3/8 + argon	0.32	0.27	0.40	0.38
Double, Low-e 2, 3/8 + argon	0.29	0.25	0.37	0.37
Double, Low-e 1, 3/8 + argon	0.29	0.25	0.36	0.36
Double, Clear 1/2	0.36	0.29	0.44	0.41
Double, Clear 1/2 + argon	0.34	0.28	0.42	0.40
Double, Low-e 4, 1/2	0.32	0.27	0.40	0.38
Double, Low-e 2, 1/2	0.30	0.26	0.38	0.37
Double, Low-e 1, 1/2	0.19	0.25	0.36	0.36
Double, Low-e 4, 1/2 + argon	0.30	0.26	0.38	0.37
Double, Low-e 2, 1/2 + argon	0.28	0.25	0.36	0.36
Double, Low-e 1, 1/2 + argon	0.28	0.24	0.34	0.35
Triple, Clear 1/4	0.31	0.26	0.39	0.38
Triple, Clear 1/4 + argon	0.29	0.25	0.37	0.37
Triple, Low-e 4, 1/4	0.30	0.26	0.38	0.37
Triple, Low-e 2, 1/4	0.29	0.25	0.37	0.36
Triple, Low-e 4, 1/4 + argon	0.27	0.24	0.35	0.35
Triple, Low-e 2, 1/4 + argon	0.26	0.24	0.34	0.35

For SI: 1 inch = 25.4 mm.

- a. Subtract 0.02 from the listed default *U*-factor for insulated spacers. Insulated spacer material includes fiberglass, wood and butyl or other material with an equivalent *K*-value.
- b. 1/4" = a minimum dead air space of 0.25 inch (6.4 mm) between the panes of glass.
 3/8" = a minimum dead air space of 0.375 inch (9.5 mm) between the panes of glass.
 1/2" = a minimum dead air space of 0.5 inch (12.7 mm) between the panes of glass.
 Products with air spaces different than those listed above shall use the value for the next smaller air space; i.e., 3/4 inch = 1/2-inch *U*-factor, 7/16 inch = 3/8-inch *U*-factor, 5/16 inch = 1/4-inch *U*-factor.
- c. Low-e 4 (emissivity) shall be 0.4 or less. Low-e 2 (emissivity) shall be 0.2 or less. Low-e 1 (emissivity) shall be 0.1 or less.
- d. *U*-factors listed for argon shall consist of sealed, gas-filled, insulated units for argon, CO², SF₆ and argon/SF₆ mixtures. The following conversion factor shall apply to Krypton gas-filled units: 1/4-inch or greater airspace with Krypton gas fill = 1/2 -inch airspace with Argon gas-fill.
- e. Dividers placed between glazing: The *U*-factors listed shall be used where the divider has a minimum gap of 1/8 inch between the divider and lite of each inside glass surface. Add 0.03 to the listed *U*-factor for true divided lite windows.
- f. Insulated = Any urethane insulated foam core door with a thermal break. Thermal Break = A thermal break door shall incorporate the following minimum design characteristics:
 - 1. The thermal conductivity of the thermal break material shall be not more than 3.6 Btu-in/h/ft²°F; and
 - 2. The thermal break material shall not be less than 0.210 inch.
- g. Wood = Any wood door.
- h. Full lite = A door that consists of more than 35-percent glazing.
- i. Add 0.05 to the listed *U*-factor for full-lite values if insulated door does not have a thermal break.
- j. Half lite = A door that consists of 35-percent or less glazing.
- k. Add 0.06 to the listed *U*-factor for half-lite values if the insulated door does not have a thermal break.

Part IV – Mechanical

CHAPTER 12 MECHANICAL ADMINISTRATION

SECTION M1201 GENERAL

M1201.1 Scope. The provisions of Chapters 12 through 24 shall regulate the design, installation, ~~maintenance~~, alteration and inspection of mechanical systems that are permanently installed and those systems used to control environmental conditions within buildings. These chapters shall also regulate those mechanical systems, system components, *equipment* and *appliances* specifically addressed in this code.

Note: Boilers, pressure vessels and associated pressure piping are regulated by the Oregon Boiler and Pressure Vessel Specialty Code and expressly administered and enforced by the State of Oregon, Building Codes Division. Any boiler or pressure vessel separated from the potable water system by an approved backflow prevention device shall have an installation permit and inspection and be approved with a permit to operate by the State of Oregon, Building Codes Division Boiler and Pressure Vessel Program. Such installations in single-family dwellings shall be exempt from subsequent inspections required by ORS 480.560. See ORS 480.525(1)(b)(A)-(D).

Storage type water heaters that heat potable water for domestic and space heating use, which are equipped with approved safety devices and operate at or below all of the following, are regulated by the Plumbing Code and Chapter 20 of this code:

1. Volumes of 120 gallons (454 L), or
2. Water temperature of 210°F (99°C), or
3. 150 pounds (68 kg) operating pressure, or
4. 200,000 Btu (211 000 kJ) input.

SECTION M1202 EXISTING MECHANICAL SYSTEMS

IRC M1202.3 Maintenance. ...*Not adopted*

CHAPTER 13

GENERAL MECHANICAL SYSTEM REQUIREMENTS

SECTION M1301 GENERAL

M1301.1.1 Flood-resistant installation. In flood hazard areas as established by [the floodplain administrator](#) ~~Table R301.2~~, mechanical *appliances, equipment* and systems shall be located or installed in accordance with Section R322.1.6.

M1301.2 Identification. Each length of pipe and tubing ~~and each pipe fitting~~ utilized in a mechanical system shall bear the identification of the manufacturer.

SECTION M1303 LABELING OF APPLIANCES

[Solid fuel-burning devices, as defined by the Oregon Department of Environmental Quality under OAR 340-262-0020, shall bear a DEQ certification label.](#)

SECTION M1305 APPLIANCE ACCESS

M1305.1.2 Appliances in attics. *Attics* containing *appliances* shall be provided with an opening and a clear and unobstructed passageway large enough to allow removal of the largest *appliance*, but not less than 30 inches (762 mm) high and 22 inches (559 mm) wide and not more than 20 feet (6096 mm) long measured along the centerline of the passageway from the opening to the *appliance*. The passageway shall have continuous solid flooring in accordance with Chapter 5 not less than 24 inches (610 mm) wide. A level service space not less than 30 inches (762 mm) deep and 30 inches (762 mm) wide shall be present along all sides of the *appliance* where access is required. The clear access opening dimensions shall be not less than of 20 inches by 30 inches (508 mm by 762 mm), and large enough to allow removal of the largest *appliance*.

Exceptions:

1. The passageway and level service space are not required where the *appliance* can be serviced and removed through the required opening.
2. Where the passageway is unobstructed and not less than 6 feet (1829 mm) high and 22 inches (559 mm) wide for its entire length, the passageway shall be not more than 50 feet (15 250 mm) long.
3. [In existing structures, the access opening shall be large enough for removal and replacement of the largest piece of the equipment.](#)

M1305.1.2.1 Electrical requirements. A luminaire controlled by a switch located at the required passageway opening and a receptacle outlet shall be installed at or near the *appliance* location in accordance with [the Electrical Code](#). ~~Exposed lamps shall be protected from damage by location or lamp guards.~~

M1305.1.3 Appliances under floors. Underfloor spaces containing *appliances* shall be provided with an unobstructed passageway large enough to remove the largest *appliance*, but not less than 30 inches (762 mm) high and 22 inches (559 mm) wide, nor more than 20 feet (6096 mm) long measured along the centerline of the passageway from the opening to the *appliance*. A level service space not less than 30 inches (762 mm) deep and 30 inches (762 mm) wide shall be present at the front or service side of the *appliance*. If the depth of the passageway or the service space exceeds 12 inches (305 mm) below the adjoining grade, the walls of the passageway shall be lined with concrete or masonry extending 4 inches (102 mm) above the adjoining grade in accordance with Chapter 4. The rough-framed access opening dimensions shall be not less than 22 inches by 30 inches (559 mm by 762 mm), and large enough to remove the largest *appliance*.

Exceptions:

1. The passageway is not required where the level service space is present when the access is open, and the *appliance* can be serviced and removed through the required opening.
2. Where the passageway is unobstructed and not less than 6 feet (1829 mm) high and 22 inches (559 mm) wide for its entire

length, the passageway shall not be limited in length.

- [3. In existing structures, the access opening shall be large enough for removal and replacement of the largest piece of the equipment.](#)

M1305.1.3.3 Electrical requirements. A luminaire controlled by a switch located at the required passageway opening and a receptacle outlet shall be installed at or near the *appliance* location in accordance with [the *Electrical Code*](#). ~~Exposed lamps shall be protected from damage by location or lamp guards.~~

SECTION M1307 APPLIANCE INSTALLATION

Section M1307.2 New amendment

Section was revised to refer to the OPSC for seismic anchoring of water heater requirements.

M1307.2 Anchorage of appliances. *Appliances* designed to be fixed in position shall be fastened or anchored in an *approved* manner. [Water heaters shall be anchored or strapped to resist horizontal displacement due to earthquake motion in accordance with the *Plumbing Code*.](#)

[The rest of this section is not adopted and is deleted.]

M1307.3 Appliances in garages. ~~Elevation of ignition source.~~ *Appliances* having an *ignition source* shall be elevated such that the source of ignition is not less than 18 inches (457 mm) above the floor in garages. For the purpose of this section, rooms or spaces that are not part of the *living space* of a *dwelling unit* and that communicate with a private garage through openings shall be considered to be part of the garage. *[The exception remains unchanged.]*

M1307.3.1 Protection from impact. *Appliances* shall not be installed in a location subject to vehicle damage except where protected by *approved* barriers. [See Figure M1307.3.1 for examples of typical motor vehicle paths and acceptable methods of protection.](#)

M1307.4.3 Specially [designed](#), ~~engineered~~ installations. As an alternative to the provisions of Sections M1307.4.1 and M1307.4.2, the necessary supply of air for *ventilation* and dilution of flammable gases shall be provided by an *approved* [designed](#) ~~engineered~~ system.

Solid fuel-burning devices. The installation of used solid fuel burning devices defined and regulated by the Oregon Department of Environmental Quality's OAR 340-262-0020 (wood-burning room heaters as used in this code) is prohibited.

Exceptions:

- [Solid fuel-burning devices certified as new on or after July 1, 1986, under rules adopted pursuant to OAR 340-262-0030.](#)
 - [Antique solid fuel-burning devices pursuant to OAR 340-262-0040.](#)
- The following definitions taken from the Oregon Department of Environmental Quality's OAR 340-262-0020 are not a part of this code but are reproduced here for the reader's convenience:
- ANTIQUÉ WOOD STOVE** means a wood stove built before 1940 that has an ornate construction and a current market value substantially higher than a common wood stove manufactured in the same time period.
- PELLET STOVE** means a wood-burning heating appliance which uses wood pellets as its primary source of fuel.
- USED SOLID FUEL-BURNING STOVE** means any wood stove that has been sold, bargained, exchanged, given away or has had its ownership transferred from a retailer, manufacturer's dealer or agent to a consumer.
- WOOD STOVE or WOOD HEATER** means an enclosed wood-burning appliance capable of and intended for space heating and domestic water heating that meets all the following criteria:
- [An air-to-fuel ratio in the combustion chamber averaging less than 35-to-1 as determined by the test procedure prescribed in federal regulations 40 CFR, Part 60, Subpart AAA, §60.534 performed at an accredited laboratory;](#)
 - [A usable firebox volume of less than 20 cubic feet \(0.57 m³\);](#)
 - [A minimum burn rate less than 5 kg/hr as determined by the test procedure prescribed in federal regulations, 40 CFR, Part 60, Subpart AAA, §60.534 performed at an accredited laboratory; and](#)
 - [A maximum weight of 800 kg. In determining the weight of an appliance for these purposes, fixtures and devices that are normally sold separately, such as flu pipe, chimney, heat distribution ducting, and masonry components that](#)

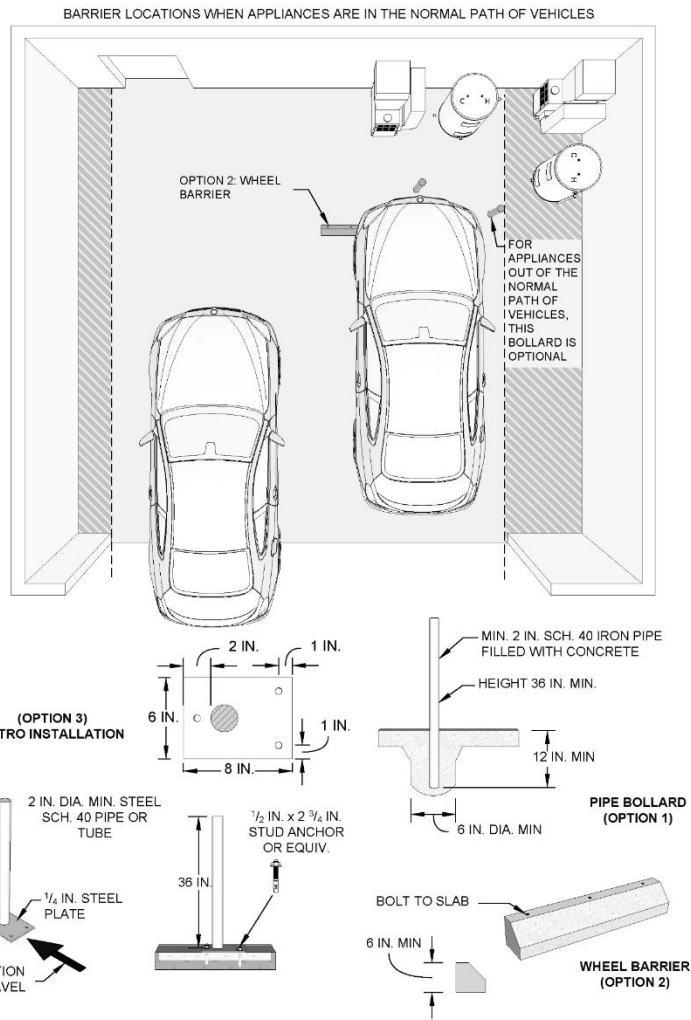

or SI: 1 inch = 25.4 mm

FIGURE M1307.3.1
TYPICAL MOTOR VEHICLE IMPACT PROTECTION

SECTION M1308 MECHANICAL SYSTEMS INSTALLATION

M1308.3 Foundations and supports. Foundations and supports for outdoor mechanical systems shall be raised at least 3 inches (76 mm) above the finished grade and shall also conform to the *manufacturer's installation instructions*.

Exception: Exterior air-conditioning condensing units may be supported on an adequately sloped grade level concrete pad or slab, such as a patio, driveway, RV pad or walkway.

SECTION M1309 PIPING SUPPORT

M1309.1 General. Where mechanical system piping support requirements are not specified in other sections of this code, mechanical system piping shall be supported in accordance with this section.

M1309.2 Materials. Pipe hangers and supports shall have sufficient strength to withstand all anticipated static and specified dynamic loading conditions associated with the intended use. Pipe hangers and supports that are in direct contact with piping shall be of *approved* materials that are compatible with the piping and that will not promote galvanic action.

M1309.3 Structural attachment. Hangers and anchors shall be attached to the building construction in an *approved* manner.

M1309.4 Interval of support. Piping shall be supported at distances not exceeding the spacing specified in Table M1309.4 or piping shall be supported in accordance with MSS SP-58.

**TABLE M1309.4
HANGER SPACING INTERVALS**

<u>PIPING MATERIAL</u>	<u>MAXIMUM HORIZONTAL SPACING (feet)</u>	<u>MAXIMUM VERTICAL SPACING (feet)</u>
<u>ABS</u>	<u>4</u>	<u>10^a</u>
<u>CPVC ≤ 1-inch pipe or tubing</u>	<u>3</u>	<u>5^a</u>
<u>CPVC ≥ 1¼ inches</u>	<u>4</u>	<u>10^a</u>
<u>Copper or copper-alloy pipe</u>	<u>12</u>	<u>10</u>
<u>Copper or copper-alloy tubing</u>	<u>6</u>	<u>10</u>
<u>PB pipe or tubing</u>	<u>2.67</u>	<u>4</u>
<u>PE pipe or tubing</u>	<u>2.67</u>	<u>4</u>
<u>PE-RT ≤ 1 inch</u>	<u>2.67</u>	<u>10^a</u>
<u>PE-RT ≥ 1¼ inches</u>	<u>4</u>	<u>10^a</u>
<u>PEX tubing ≤ 1 inch</u>	<u>2.67</u>	<u>4</u>
<u>PEX tubing ≥ 1¼ inches</u>	<u>4</u>	<u>10^a</u>
<u>PP < 1-inch pipe or tubing</u>	<u>2.67</u>	<u>4</u>
<u>PP > 1¼ inches</u>	<u>4</u>	<u>10^a</u>
<u>PVC</u>	<u>4</u>	<u>10^a</u>
<u>Steel pipe</u>	<u>12</u>	<u>15</u>
<u>Steel tubing</u>	<u>8</u>	<u>10</u>

For SI: 1 inch = 25.4 mm, 1 foot = 304.8 mm.

- a. For sizes 2 inches and smaller, a guide shall be installed midway between required vertical supports. Such guides shall prevent pipe movement in a direction perpendicular to the axis of the pipe.

CHAPTER 14

HEATING AND COOLING EQUIPMENT AND APPLIANCES

SECTION M1401 GENERAL

M1401.5 Flood hazard. In flood hazard areas as established by [the floodplain administrator](#) ~~Table R301.2~~, heating and cooling equipment and appliances shall be located or installed in accordance with Section R322.1.6.

SECTION M1407 DUCT HEATERS

M1407.1 General. Electric duct heaters shall be installed in accordance with the manufacturer's instructions and [the Electrical Code](#). ~~Electric duct heaters shall comply with UL 1996.~~

SECTION M1410 VENTED ROOM HEATERS

<p>Solid fuel-burning heaters shall meet the requirements of OAR 340, Division 262.</p>

SECTION M1411 HEATING AND COOLING EQUIPMENT

M1411.3.2 Drain pipe materials and sizes. Components of the condensate disposal system shall be ABS, cast iron, copper, cross-linked polyethylene, CPVC, galvanized steel, PE-RT, polyethylene, polypropylene or PVC pipe or tubing. Components shall be selected for the pressure and temperature rating of the installation. ~~Joints and connections shall be made in accordance with the applicable provisions of Chapter 30.~~ [Material for gravity drains shall be smooth and rigid to maintain the slope to the discharge point.](#) Condensate waste and drain line size shall be not less than $\frac{3}{4}$ -inch (19 mm) nominal diameter from the drain pan connection to the place of condensate disposal. Where the drain pipes from more than one unit are manifolded together for condensate drainage, the pipe or tubing shall be sized in accordance with an *approved* method.

CHAPTER 15

EXHAUST SYSTEMS

SECTION M1502 CLOTHES DRYER EXHAUST

M1502.3 Duct termination. Exhaust ducts shall terminate on the outside of the building. Exhaust duct terminations shall be made with a full opening exhaust outlet or in accordance with the dryer manufacturer's installation instructions. If the manufacturer's instructions do not specify a termination location, the exhaust duct shall terminate not less than 3 feet (914 mm) in any direction from openings into buildings, **including openings in ventilated soffits**. Exhaust duct terminations shall be equipped with a backdraft damper. Screens shall not be installed at the duct termination.

M1502.4.2 Duct installation. Exhaust ducts shall be supported at intervals not to exceed ~~12 feet (3658 mm)~~ 4 feet (1219 mm) and shall be secured in place. The insert end of the duct shall extend into the adjoining duct or fitting in the direction of airflow. Exhaust duct joints shall be sealed with listed tape ~~in accordance with Section M1601.4.1 and shall be mechanically fastened~~. Ducts shall not be joined with screws or similar fasteners that protrude ~~more than 1/8 inch (3.2 mm)~~ into the inside of the duct. Where dryer exhaust ducts are enclosed in wall or ceiling **cavities**, such cavities shall allow the installation of the duct without deformation.

M1502.4.3 Transition duct. Transition ducts used to connect the dryer to the exhaust *duct system* shall be a single length ~~that is listed and labeled in accordance with UL-2158A~~. Transition ducts shall be not greater than 8 feet (2438 mm) in length. Transition ducts shall not be concealed within construction.

(Errata issued April 2024)

M1502.6 Exhaust penetrations. Ducts that exhaust clothes dryers shall not penetrate or be located within any fireblocking; draftstopping; or any wall, floor/ceiling or other assembly required by this code to be fire-resistance rated, unless such duct is constructed of galvanized steel or aluminum of the thickness specified in Table M1601.1.1(2) and the fire-resistance rating is maintained in accordance with Section R302. Fire dampers, combination fire/smoke dampers and any similar devices that will obstruct the exhaust flow shall be prohibited in clothes dryer exhaust ducts.

M1502.7 Makeup air. Installations exhausting more than 200 cubic feet per minute (0.09 m³/s) shall be provided with makeup air. Where a closet is designed for the installation of a clothes dryer, an opening having an area of not less than 100 square inches (0.0645 m²) shall be provided in the closet enclosure.

SECTION M1503 DOMESTIC COOKING EXHAUST EQUIPMENT

M1503.1 General. Domestic cooking ~~exhaust~~ equipment shall be provided with exhaust equipment ~~comply with the requirements of this section~~.

M1503.2 Domestic cooking exhaust. ~~Where~~ Domestic cooking exhaust equipment ~~is provided, it~~ shall comply with one of the following:

[Items 1 through 4 remain unchanged.]

M1503.2.1 Open-top broiler exhaust. Domestic open-top broiler units shall be provided with a metal exhaust hood having a thickness of not less than 0.0157 inch (0.3950 mm) (No. 28 gage). Such hoods shall be installed with a clearance of not less than 1/4 inch (6.4 mm) between the hood and the underside of *combustible material* and cabinets. ~~A clearance of not less than 24 inches (610 mm) shall be maintained between the cooking surface and combustible material and cabinets.~~ The hood width shall be not less than the width of the broiler unit and shall extend over the entire unit.

Exception: Broiler units that incorporate an integral exhaust system, and that are *listed* and *labeled* for use without an exhaust hood, shall not be required to have an exhaust hood.

M1503.3 Exhaust discharge. Domestic cooking exhaust equipment shall discharge to the outdoors through a duct. The duct shall have a smooth interior surface, shall be airtight, shall be equipped with a backdraft damper and shall be independent of all other exhaust systems. Ducts serving domestic cooking exhaust equipment shall not terminate in an attic or *crawl space* or areas inside the building.

Exception: Where installed in accordance with the manufacturer's instructions, ~~and where mechanical or natural ventilation is otherwise provided,~~ listed and labeled ductless range hoods shall not be required to discharge to the outdoors ~~where all the following conditions are met:~~

1. Where continuous mechanical exhaust of not less than 20 cubic feet per minute (0.0094 m³/s) is provided in the space.
2. Natural ventilation is provided in accordance with Section R303.1, without exception, for the kitchen.

M1503.5 Kitchen exhaust rates. ~~Where~~ Domestic kitchen cooking appliances ~~are~~ shall be equipped with ducted range hoods or down-draft exhaust systems, the fans shall be sized in accordance with Section 1505.5.

M1503.6 Makeup air required. ~~Where one or more gas, liquid or solid fuel burning appliance that is neither direct vent nor uses a mechanical draft venting system is located within a dwelling unit's air barrier,~~ Each exhaust system capable of exhausting in excess of 400 cubic feet per minute (0.19 m³/s) shall be mechanically or passively provided with makeup air at a rate approximately equal to the exhaust air rate. Such makeup air systems shall be equipped with not fewer than one damper complying with Section M1503.6.2.

Exception: Makeup air is not required for exhaust systems installed for the exclusive purpose of space cooling and intended to be operated only when windows or other air inlets are open.

SECTION M1504 EXHAUST DUCTS AND EXHAUST OPENINGS

M1504.3 – New amendment

This code change is an approved code change for the 2024 IRC.

A new exception has been added allowing reduced clearance where factory-built combination intake or exhaust fittings are used.

M1504.3 Exhaust openings. Air exhaust openings shall terminate as follows:

- ~~1. Not less than 3 feet (914 mm) from property lines.~~
 1. Not less than 3 feet (914 mm) from gravity air intake openings, operable windows and doors.
 2. Not less than 10 feet (3048 mm) from mechanical air intake openings except where one of the following apply:
 - 2.1. The exhaust opening is located not less than 3 feet (914 mm) above the air intake opening.
 - 2.2. The exhaust opening is part of a factory-built intake/exhaust combination termination fitting installed in accordance with the fan manufacturer's instructions, and the exhaust air is drawn from a living space.
3. Openings shall comply with Sections R303.5.2 and R303.6.

IRC Table M1504.2 Duct Length. ...*Not adopted and is replaced with the following:*

**TABLE M1504.2
PRESCRIPTIVE EXHAUST DUCT SIZING**

<u>FAN TESTED (CFM @ 0.10 inch w.g.)</u>	<u>MINIMUM METAL FLEX DIAMETER (inches)</u>	<u>MAXIMUM LENGTH (feet)</u>	<u>MINIMUM SMOOTH DIAMETER (inches)</u>	<u>MAXIMUM LENGTH (feet)</u>	<u>MAXIMUM ELBOWS^a</u>
50	4	25	4	70	3
	5	90	5	100	3
	6	No limit	6	No limit	3
80	4 ^b	N/A	4	20	3
	5	15	5	100	3
	6	90	6	No limit	3
100	5 ^b	N/A	5	50	3
	6	45	6	No limit	3
125	6	15	6	No limit	3
	7	70	7	No limit	3
160	6	4	6	40	3
	7	50	7	100	3

For SI: 1 inch = 25.4 mm, 1 foot = 304.8 mm, 1 cubic foot per minute = 0.0004719 m³/s.

N/A = Not Applicable.

- a. For each additional elbow, subtract 10 feet from length.
- b. Metal flex ducts of this diameter are not permitted with fans of this size.

SECTION M1505 MECHANICAL VENTILATION

M1505.1 General. Where Section R303.3 requires toilet rooms, bathrooms, and rooms with bathing or spa facilities to be mechanically ventilated, the ventilation equipment shall be installed in accordance with this section. Where local exhaust or whole-house mechanical ventilation is provided, the ventilation system shall be designed in accordance with this section and the applicable provisions of Chapter 11.

M1505.2 Recirculation of air. Exhaust air from range hoods, bathrooms, and toilet rooms and rooms with bathing or spa facilities shall not be recirculated within a residence or circulated to another dwelling unit and shall be exhausted directly to the outdoors. Exhaust air from bathrooms, toilet rooms and kitchens shall not discharge into an attic, crawl space or other areas inside the building. This section shall not prohibit the installation of ductless range hoods in accordance with the exception to Section M1503.3.

M1505.4.1 System design. The whole-house mechanical ventilation system shall be a balanced ventilation system ~~consist of one or more supply or exhaust fans, or a combination of such, and associated ducts and controls~~. Local exhaust or supply fans are permitted to serve as such a system. Outdoor air ventilation provided by a supply fan ducted ~~ducts connected to the~~ return side of an air handler shall be considered as providing supply ventilation for the balanced ventilation system.

M1505.4.2 System controls. The whole-house mechanical ventilation system shall be provided with readily accessible user controls that enable manual override by the occupant. Controls shall include text or a symbol indicating their function.

M1505.4.3 Mechanical ventilation rate. The *whole-house mechanical ventilation system* shall provide outdoor air at a continuous rate **not less than that** determined in accordance with Table M1505.4.3(1) or **not less than that determined by** Equation 15-1.

Ventilation rate in cubic feet per minute =
 $(0.01 \times \text{total square foot area of house}) + [7.5 \times (\text{number of bedrooms} + 1)]$ **(Equation 15-1)**

Exceptions:

1. Ventilation rate credit. The minimum mechanical ventilation rate determined in accordance with Table M1505.4.3(1) or Equation 15-1 shall be reduced by 30 percent, provided that both of the following conditions apply:
 - 1.1. A ducted system supplies ventilation air directly to each bedroom and to one or more of the following rooms:
 - 1.1.1. Living room.
 - 1.1.2. Dining room.
 - 1.1.3. Kitchen.
 - 1.2. The *whole-house mechanical ventilation system* is a *balanced ventilation system*.
2. Programmed intermittent operation. The *whole-house mechanical ventilation system* is permitted to operate intermittently where the system has controls that enable operation for not less than 25 percent of each 4-hour segment and the ventilation rate prescribed in Table M1505.4.3(1), by Equation 15-1 or by Exception 1 is multiplied by the factor determined in accordance with Table M1505.4.3(2).

IRC M1505.4.4 Local exhaust rates. ...*Not adopted.*

IRC Table M1505.4.4 Minimum Required. ...*Not adopted.*

M1505.5 Exhaust ventilation rate. Ventilation systems shall be designed to have the capacity to exhaust the minimum airflow rate determined in accordance with Table M1505.5. Exhaust flow ratings shall be source-specific ventilation systems and shall be in accordance with the Home Ventilating Institute (HVI) or Air Movement and Control Association (AMCA) residential ventilation standards. Fans shall be Energy Star certified in accordance with Section N1105.6.

M1505.5.1 Sound ratings for fans in rooms with bathing or spa facilities.

M1505.5.1.1 Continuous ventilation fans. Continuous ventilation fans shall be rated for sound at a maximum of 1.0 sone.

M1505.5.1.2 Intermittent fans. Intermittent fans shall be rated for sound at a maximum of 3 sones, unless the maximum rated airflow exceeds 400 cubic feet per minute (0.189m³/s).

M1505.5.1.3 Remote fans. Remotely installed fans that are at least 4 feet (1220 mm) away from the inlet grill are exempt from the sone rating requirements of Sections M1505.5.1.1 and M1505.5.1.2.

M1505.6 Rooms with water closets, bathing facilities or spa facilities. Rooms containing water closets, bathing facilities or spa facilities provided with a mechanical ventilation system shall be controlled by a timer or other *approved* means of automatic control.

**TABLE M1505.5
EXHAUST RATES FOR RESIDENTIAL DWELLINGS**

DOMESTIC KITCHENS	
<u>Range hoods/downdraft exhaust</u>	<u>Min. 150 cfm intermittent</u>
BATHROOMS/TOILET ROOMS	
<u>Rooms containing bathing and spa facilities. (Static pressure shall be rated @ 0.10-inch water gauge for intermittent fans.)</u>	<u>Min. 80 cfm intermittent or 20 cfm continuous</u>
<u>Toilet rooms without bathing or spa facilities, where not provided with natural ventilation in accordance with Section R303.3.2.</u>	<u>Min. 50 cfm</u>

For SI: 1 cubic foot per minute = 0.0004719 m³/s.

CHAPTER 16

DUCT SYSTEMS

SECTION M1601 DUCT CONSTRUCTION

M1601.1.1 Above-ground duct systems. Above-ground *duct systems* shall conform to the following:

[Items 1 through 4 remain unchanged.]

~~5. The use of gypsum products to construct return air ducts or plenums is permitted, provided that the air temperature does not exceed 125°F (52°C) and exposed surfaces are not subject to condensation.~~

[The rest of this section is renumbered.]

M1601.1.1.1 Use of building cavities in new construction. Except as allowed by Section M1601.1.1, the use of building cavities for air ducts or plenums is not allowed in new construction or in an *addition* to an existing structure.

M1601.1.1.2 Use of building cavities in existing buildings. The use of building cavities for air ducts or plenums is allowed in the *alteration* or remodel of an existing structure. Gypsum products are permitted to be used to construct air ducts or plenums, provided that the air temperature does not exceed 125°F (52°C) and exposed surfaces are not subject to condensation.

Stud wall cavities and the spaces between solid floor joists to be utilized as air ducts or plenums shall comply with the following conditions:

1. Such cavities or spaces shall not be utilized as a duct or plenum for supply air.
2. Such cavities or spaces shall not be part of a required fire-resistance-rated assembly.
3. Stud wall cavities shall not convey air from more than one floor level.
4. Stud wall cavities and joist space ducts or plenums shall comply with floor penetration protection requirements of this code.
5. Stud wall cavities and joist space ducts or plenums shall be isolated from adjacent concealed spaces by tight-fitting fireblocking in accordance with Section R302.11, and sealed to prevent conveyance of air from other spaces.

M1601.1.2 Underground duct systems. Underground *duct systems* shall be constructed of *approved* concrete, clay, metal or plastic. The maximum design temperature for systems utilizing plastic duct and fittings shall be 150°F (66°C). Metal ducts shall be protected from corrosion in an *approved* manner or shall be completely encased in concrete not less than 2 inches (51 mm) thick. Nonmetallic ducts shall be installed in accordance with the manufacturer's instructions. Plastic pipe and fitting materials shall conform to cell classification 12454-B of ASTM D1248 or ASTM D1784 and external loading properties of ASTM D2412. Ducts shall slope to a drainage point that has access. Ducts shall be sealed, secured and tested prior to encasing the ducts in concrete or direct burial. ~~Duct tightness shall be verified as required by Section N1103.3.~~ Metallic ducts having an *approved* protective coating and nonmetallic ducts shall be installed in accordance with the manufacturer's instructions.

M1601.4.1 Joints, seams and connections. Longitudinal and transverse joints, seams and connections in metallic and nonmetallic ducts shall be constructed as specified in SMACNA *HVAC Duct Construction Standards—Metal and Flexible* and NAIMA *Fibrous Glass Duct Construction Standards*. Joints, longitudinal and transverse seams, and connections in ductwork shall be securely fastened and sealed with welds, gaskets, mastics (adhesives), mastic-plus-embedded-fabric systems, liquid sealants or tapes. Tape shall not be used to seal metal ductwork or be used as the only sealing method between metal duct and flexible or fibrous duct. Tape is permitted to be used with metal duct at connections to equipment requiring future replacement. Tapes and mastics used to seal fibrous glass ductwork shall be *listed* and *labeled* in accordance with UL 181A and shall be marked "181A-P" for pressure-sensitive tape, "181 A-M" for mastic or "181 A-H" for heat-sensitive tape.

[The rest of this section remains unchanged.]

M1601.4.4 Support. Factory-made ducts *listed* in accordance with UL 181 shall be supported in accordance with the manufacturer's installation instructions. Field- and shop-fabricated fibrous glass ducts shall be supported in accordance with the SMACNA *Fibrous Glass Duct Construction Standards* or the NAIMA *Fibrous Glass Duct Construction Standards*. Metal ducts shall be supported by 1/2-inch (13 mm) wide 18-gage metal straps or 12-gage galvanized wire at intervals not exceeding 10 feet (3048 mm) or other approved means. ~~Field- and shop-fabricated metal and flexible ducts shall be supported in accordance with the SMACNA *HVAC Duct Construction Standards—Metal and Flexible*.~~

M1601.4.6 Duct insulation. Duct insulation shall be installed in accordance with [Section N1105.2](#) and the following requirements:

~~1. A vapor retarder having a permeance of not greater than 0.05 perm [2.87 ng/(s × m² × Pa)] in accordance with ASTM E96, or aluminum foil with a thickness of not less than 2 mils (0.05 mm), shall be installed on the exterior of insulation on cooling supply ducts that pass through unconditioned spaces conducive to condensation except where the insulation is spray polyurethane foam with a water vapor permeance of not greater than 3 perms per inch [1722 ng/(s × m² × Pa)] at the installed thickness.~~

~~1.2.~~ Outdoor duct systems shall be protected against the elements.

~~2.3.~~ Duct coverings shall not penetrate a fireblocked wall or floor.

M1601.4.8 Duct separation. Ducts shall be installed with not less than 4 inches (102 mm) separation from earth except where they meet the requirements of Section M1601.1.2.

Exception: [Where approved groundcover is placed between the earth and the duct, a minimum 1-inch \(25.4 mm\) separation from the earth shall be allowed.](#)

M1601.4.10 Flood hazard areas. In flood hazard areas as established by [the floodplain administrator](#) ~~Table R301.2~~, duct systems shall be located or installed in accordance with Section R322.1.6.

[M1601.4.11 Ductwork installation location.](#) [All supply and return ductwork shall be installed within the building thermal envelope in accordance with Section N1105.3.](#)

M1601.5 Under-floor plenums. [A crawlspace shall not be used as a supply or return air plenum.](#) ~~Under floor plenums shall be prohibited in new structures. Modification or repairs to under floor plenums in existing structures shall conform to the requirements of this section.~~

IRC M1601.5.1 General. ...*Not adopted.*

IRC M1601.5.2 Materials. ...*Not adopted.*

IRC M1601.5.3 Furnace connections. ...*Not adopted.*

IRC M1601.5.4 Access. ...*Not adopted.*

IRC M1601.5.5 Furnace controls. ...*Not adopted.*

SECTION M1602 RETURN AIR

M1602.2 Return air openings. Return air openings for heating, ventilation and air-conditioning systems shall comply with all of the following:

[Items 1 and 2 remain unchanged.]

3. Return and transfer openings shall be sized in accordance with the appliance or equipment manufacturer's installation instructions, Manual D or ~~the~~ [an approved](#) design ~~of the registered design professional.~~

[Items 4 and 5 remain unchanged.]

~~6. Taking return air from an unconditioned crawl space shall not be accomplished through a direct connection to the return side of a forced air furnace. Transfer openings in the crawl space enclosure shall not be prohibited.~~

~~6.7.~~ Return air from one dwelling unit shall not be discharged into another dwelling unit.

SECTION M1603 SMOKE AND FIRE DAMPER

[M1603.1 General.](#) [Where the penetration of a fire-resistive assembly is beyond the scope of Section R302.4, the protection of duct penetrations and air transfer openings in fire-resistance-rated assemblies shall comply with Section 607 of the Mechanical Code.](#)

CHAPTER 17 COMBUSTION AIR

SECTION M1701 GENERAL

M1701.2 Opening location. In flood hazard areas as established by the floodplain administrator in Table R301.2, combustion air openings shall be located at or above the elevation required in Section R322.2.1 or R322.3.2.

CHAPTER 18 CHIMNEYS AND VENTS

SECTION M1801 GENERAL

M1801.1.1 Enclosing of venting systems. Portions of venting systems that extend through occupied spaces or storage spaces shall be enclosed to avoid personal contact with the vent or damage to the vent.

SECTION M1802 VENT COMPONENTS

Section M1802.4 – Model code change

An additional safety device for oil-fired appliances has been added to be consistent with what is required for some gas-fired appliances.

M1802.4 Blocked vent switch. Oil-fired *appliances* shall be equipped with a device that will stop burner operation in the event that the venting system is obstructed. Such device shall have a manual reset and shall be installed in accordance with the manufacturer's instructions.

SECTION M1804 VENTS

M1804.3.2 Size of multiple-appliance venting systems. Two or more *listed and labeled appliances* connected to a common natural draft venting system shall comply with the following requirements:

1. *Appliances* that are connected to common venting systems shall be located on the same floor of the *dwelling*.
Exception: Engineered systems.
 2. Inlets to common venting systems shall be offset such that no portion of an inlet is opposite another inlet.
 3. Connectors serving *appliances* operating under natural draft shall not be connected into any portion of a mechanical draft system operating under positive pressure.
 4. Unless *listed and labeled* for such connection, solid fuel-burning *appliances* shall not be connected to a vent serving *appliances* burning other fuels.
 5. Where two or more vent connectors enter a common vent, the smaller connector shall enter at the highest level consistent with the available headroom and clearance to combustible material.
 6. Automatically controlled gas *appliances* connected to a chimney that also serves equipment-burning liquid fuel shall be equipped with an automatic pilot. A gas *appliance* vent connector and a chimney connector from an *appliance* burning liquid fuel may be connected into the same chimney through separate openings, provided that the gas *appliance* is vented above the liquid-fuel-burning *appliance*, or both may be connected through a single opening if joined by a suitable fitting located at the chimney.
-

M1804.3.2.1 Multiple-appliance venting. Existing lined masonry chimneys and unlined chimneys with not more than one side exposed to the outside may be used to common vent oil and gas *appliances* equipped with draft hoods, provided that:

1. An *approved* liner shall be installed in an existing unlined masonry chimney where deemed necessary by the *building official* considering local problems of vent gas condensate.
2. The effective cross-sectional area is not more than four times the cross-sectional area of the vent and chimney connectors entering the chimney.
3. The effective area of the chimney when connected to more than one *appliance* shall not be less than the area of the largest vent or chimney connector plus 50 percent of the area of the additional vent or chimney connectors.
4. Automatically controlled gas *appliances* connected to a chimney that also serves equipment burning liquid fuel shall be equipped with an automatic pilot. A gas *appliance* vent connector and a chimney connector from an *appliance* burning liquid fuel may be connected into the same chimney through separate openings, provided that the gas *appliance* is vented above the liquid-fuel-burning *appliance*, or both may be connected through a single opening if joined by a suitable fitting located at the chimney.
5. The chimney passageway shall comply with Section M1801.3.2.
6. The vent or chimney connector shall enter the chimney at least 6 inches (153 mm) from the bottom of the chimney. The chimney shall be provided with a cleanout. If the 6-inch (153 mm) clearance is not available, a cleanout shall be provided by installing a capped tee in the vent connector next to the chimney.

Unlined chimneys with more than one side exposed to the outside shall be lined with an *approved* liner unless otherwise approved by the *building official*.

Where inspection reveals that an existing chimney is not safe for the intended application, it shall be rebuilt to conform to chimney standards in Chapter 10 or replaced with an *approved* factory-built chimney.

CHAPTER 19

SPECIAL APPLIANCES, EQUIPMENT AND SYSTEMS

SECTION M1903 ENGINE AND GAS TURBINE-POWERED EQUIPMENT

M1903.1 Powered equipment. Permanently installed equipment powered by internal combustion engines and turbines shall be *listed* and *labeled* and shall be installed in accordance with the manufacturer's installation instructions.

SECTION M1904 SMALL CERAMIC KILNS

M1903.1 Powered equipment. Permanently installed equipment powered by internal combustion engines and turbines shall be *listed* and *labeled* and shall be installed in accordance with the manufacturer's installation instructions.

M1904.1 General. The provisions of this section apply to unlisted kilns used for ceramics that have a maximum interior volume of 20 cubic feet (0.57 m³).

M1904.2 Fuel-gas controls. Standing pilots shall not be used with gas-fired kilns.

M1904.3 Electric equipment. All electric equipment used as part of, or in connection with, the installation of a kiln shall be in accordance with the *Electrical Code*.

M1904.4 Installation inside building. In addition to other requirements specified in this section, interior installation shall meet the requirements of Sections M1904.4.1 through M1904.4.5.

M1904.4.1 Kiln clearance. The sides and tops of kilns shall be located a minimum of 18 inches (457 mm) from any noncombustible wall surface and 3 feet (914 mm) from any combustible wall surface. Kilns shall be installed on noncombustible flooring consisting of at least 2 inches (51 mm) of solid masonry or concrete extending at least 12 inches (305mm) beyond the base or supporting members of the kiln.

Exception: These clearances may be reduced, provided the kiln is installed in accordance with its *listing* or to acceptable conclusions of testing reports submitted to the *building official*. In no case shall the clearance on the gas or electrical control side of a kiln be reduced to less than 30 inches (762 mm).

M1904.4.2 Hoods. A canopy-type hood shall be installed directly above each kiln. The face-opening area of the hood shall be equal to or greater than the top horizontal surface area of the kiln. The hood shall be constructed of not less than 0.024-inch (0.61 mm) (No. 24 US gage) galvanized steel or equivalent and be supported at a height of between 12 inches (305 mm) and 30 inches (762 mm) above the kiln by noncombustible supports.

Exception: Electric kilns installed with *listed* exhaust blowers may be used where marked as being suitable for the kiln and installed in accordance with the manufacturer's instructions.

M1904.4.3 Gravity ventilation ducts. Each hood shall be connected to a gravity ventilation duct extending in a vertical direction to outside the building. This duct shall be of the same construction as the hood and shall have a minimum cross-sectional area of not less than one-fifteenth of the face opening area of the hood. The duct shall terminate a minimum of 12 inches (305 mm) above any portion of a building within 4 feet (1219 mm) and terminate not less than 4 feet (1219 mm) from any openable windows or other openings into the building or adjacent property line. The duct opening to the outside shall be shielded, without reduction of duct area, to prevent entrance of rain into the duct. The duct shall be supported at each section by noncombustible supports.

M1904.4.4 Makeup air. Provisions shall be made for air to enter the room in which a kiln is installed at a rate at least equal to the air being removed through the kiln hood.

M1904.4.5 Hood and duct clearances. Every hood and duct serving a fuel-burning kiln shall have a clearance from combustible construction of at least 18 inches (457 mm). This clearance may be reduced in accordance with Figure M1306.1 and Table M1306.2.

M1904.5 Exterior installation. Kilns shall be installed with minimum clearances as specified in Section M1904.4.1. Wherever a kiln is located under a roofed area and is partially enclosed by more than two vertical wall surfaces, a hood and gravity ventilation duct shall be installed to comply with Sections M1904.4.2, M1904.4.3 and M1904.4.5.

CHAPTER 20

BOILERS AND WATER HEATERS

Note: Boilers, pressure vessels and associated pressure piping are regulated by the Oregon Boiler and Pressure Vessel Specialty Code and expressly administered and enforced by the State of Oregon Building Codes Division. Any boiler or pressure vessel separated from the potable water system by an approved backflow prevention device shall have an installation permit and inspection and be approved with a permit to operate by the State of Oregon, Building Codes Division, Boiler and Pressure Vessel Program. Such installations in single-family dwellings shall be exempt from subsequent inspections required by ORS 480.560. See ORS 480.525(2)(c).

SECTION M2001 BOILERS

M2001.4 Flood-resistant installation. In flood hazard areas established ~~in Table R301.2 by the floodplain administrator,~~ boilers, water heaters and their control systems shall be located or installed in accordance with Section R322.1.6.

SECTION M2005 WATER HEATERS

M2005.1 General. Water heaters shall be installed in accordance with the manufacturer's instructions, the Plumbing Code and the applicable requirements of this code. Water heaters installed in an attic shall comply with the requirements of Section M1305.1.2. Gas-fired water heaters shall comply with the requirements in Chapter 24. Domestic electric water heaters shall comply with UL 174. Oiled-fired water heaters shall comply with UL 732. Solar thermal water heating systems shall comply with Chapter 23 and SRCC 300. Solid fuel-fired water heaters shall comply with UL 2523.

SECTION M2006 POOL HEATERS

M2006.1 General. Pool and spa heaters shall be installed in accordance with the manufacturer's installation instructions. Oil-fired pool heaters shall comply with UL 726. Electric pool and spa heaters shall comply with UL 1261. Pool and spa heat pump water heaters shall comply with UL 1995 or CSA C22.2 No. 236.

Exception: Portable residential spas and portable residential exercise spas ~~shall comply with UL 1563 or CSA C22.2 No. 218.1.~~

CHAPTER 21

HYDRONIC PIPING

SECTION M2101 HYDRONIC PIPING SYSTEMS INSTALLATION

M2101.29.1 Flood hazard. Piping located in a flood hazard area, [as established by the floodplain administrator](#), shall be capable of resisting hydrostatic and hydrodynamic loads and stresses, including the effects of buoyancy, during the occurrence of flooding to the design flood elevation.

SECTION M2103 FLOOR HEATING SYSTEMS

[M2103.5 Pressurizing during installation.](#) Piping to be embedded in concrete shall be pressure tested prior to pouring concrete in accordance with Section M2103.4. During pouring, the piping shall be maintained at the proposed operating pressure.

SECTION M2105 GROUND-SOURCE HEAT-PUMP SYSTEM LOOP PIPING

M2105.22.1 Flood hazard. Piping located in a flood hazard area, [as established by the floodplain administrator](#), shall be capable of resisting hydrostatic and hydrodynamic loads and stresses, including the effects of buoyancy, during the occurrence of flooding to the *design flood elevation* [as established by the floodplain administrator](#).

CHAPTER 22

SPECIAL PIPING AND STORAGE SYSTEMS

SECTION M2201 OIL TANKS

M2201.1 Materials. Supply tanks shall be *listed* and *labeled* and shall conform to ~~UL 58 for underground tanks and~~ UL 80 for indoor tanks.

M2201.2 Above-ground tanks. The maximum amount of fuel oil stored ~~above ground or~~ inside ~~of~~ a building shall be 660 gallons (2498 L). The supply tank shall be supported on rigid noncombustible supports to prevent settling or shifting.

Exception: The storage of fuel oil, used for space or water heating, ~~above ground or~~ inside buildings in quantities exceeding 660 gallons (2498 L) shall comply with NFPA 31.

IRC M2201.2.2 Outdoor above-ground tanks. *...Not adopted.*

M2201.3 Underground tanks. Excavations for underground tanks shall not undermine the foundations of existing structures. ~~The clearance from the tank to the nearest wall of a basement, pit or property line shall be not less than 1 foot (305 mm). Tanks shall be set on and surrounded with noncorrosive inert materials such as clean earth, sand or gravel well tamped in place. Tanks shall be covered with not less than 1 foot (305 mm) of earth. Corrosion protection shall be provided in accordance with Section M2203.7.~~

IRC M2201.6 Flood-resistant installation. *...Not adopted.*

IRC M2201.7 Tanks abandoned or removed. *...Not adopted.*

SECTION M2203 INSTALLATION

IRC M2203.7 Corrosion protection. *...Not adopted.*

CHAPTER 23

SOLAR ~~THERMAL~~ ENERGY SYSTEMS

SECTION M2301 SOLAR THERMAL ENERGY SYSTEMS

M2301.1 General. This section provides for the design, construction, installation, *alteration* and *repair* of equipment and systems using solar ~~thermal energy to provide nonpotable~~ space heating or cooling, hot water heating and swimming pool heating.

M2301.2 ~~Design and~~ Installation. The ~~design and~~ installation of solar thermal energy systems shall comply with Sections M2301.2.1 through M2301.2.13.

M2301.2.3 Pressure and temperature relief valves and system components. System components containing fluids shall be protected with temperature and pressure relief valves or pressure relief valves. Relief devices shall be installed in sections of the system so that a section cannot be valved off or isolated from a relief device. ~~Direct systems and the potable water portion of indirect systems shall be equipped with a relief valve in accordance with Section P2804.~~ For indirect systems, pressure relief valves in solar loops shall comply with ICC 900/SRCC 300. System components shall have a working pressure rating of not less than the setting of the pressure relief device.

M2301.2.6 Protection from freezing. System components shall be protected from damage resulting from freezing of heat-transfer liquids at the winter design temperature provided in Table R301.2. Freeze protection shall be provided in accordance with ICC 900/SRCC 300. Drain-back systems shall be installed in compliance with Section M2301.2.6.1. Systems utilizing freeze-protection valves shall comply with Section M2301.2.6.2.

~~**Exception:** Where the 97.5 percent winter design temperature is greater than or equal to 48°F (9°C).~~

IRC M2301.7 Solar thermal systems for heating potable water. ...Not adopted.

IRC M2301.7.1 Indirect systems. ...Not adopted.

IRC M2301.7.2 Direct systems. ...Not adopted.

SECTION M2302 PHOTOVOLTAIC SYSTEMS

M2302.1 Photovoltaic systems. Photovoltaic systems shall be installed in accordance with Section R324. All electrical photovoltaic installations shall comply with the *Electrical Code*.



Part VI – Fuel Gas

CHAPTER 24 FUEL GAS

SECTION G2401 GENERAL

G2401.1 Application. This chapter covers those fuel gas *pipng systems*, fuel-gas *appliances* and related accessories, *venting systems* and *combustion air* configurations most commonly encountered in the construction of one- and two-family dwellings and structures regulated by this *code*.

Coverage of *pipng systems* shall extend from the *point of delivery* to the outlet of the *appliance* shutoff valves (see definition of “*Point of delivery*”). *Pipng systems* requirements shall include design, materials, components, fabrication, assembly, installation, testing, and inspection, ~~operation and maintenance~~. Requirements for gas *appliances* and related accessories shall include installation, combustion and ventilation air and venting and connections to *pipng systems*.

The omission from this chapter of any material or method of installation provided for in the *Mechanical Code* shall not be construed as prohibiting the use of such material or method of installation. Fuel-gas *pipng systems*, fuel-gas *appliances* and related accessories, *venting systems* and *combustion air* configurations not specifically covered in these chapters shall comply with the applicable provisions of the *Mechanical Code*.

Gaseous hydrogen systems shall be regulated by Appendix C of the *Mechanical Code*.

This chapter shall not apply to the following:

1. Liquefied natural gas (LNG) installations.
2. Temporary LP-fuel gas *pipng* for buildings under construction or renovation that is not to become part of the permanent *pipng system*.
3. Except as provided in Section G2412.1.1, gas *pipng*, meters, gas pressure regulators, and other appurtenances used by the serving gas supplier in the distribution of gas, other than undiluted LP-gas.
4. Portable LP-fuel gas *appliances* and *equipment* of all types that is not connected to a fixed fuel *pipng system*.
5. Portable fuel cell *appliances* that are neither connected to a fixed *pipng system* nor interconnected to a power grid.
6. Installation of hydrogen gas, LP-gas and compressed natural gas (CNG) systems on vehicles.

G2401.2 Authority to render gas service.

G2401.2.1 Turn on authority. A serving gas supplier or person furnishing gas shall not turn on, or cause to be turned on, fuel gas or gas meters until the approval of the rough piping inspection is in compliance with Section G2417.1.1.1.

G2401.2.2 Temporary gas service. Temporary fuel gas service shall be permitted upon approval of the municipality.

SECTION G2403 GENERAL DEFINITIONS

Oregon-Specific added or amended definitions:

DESIGN FLOOD ELEVATION. The elevation of the “design flood,” including wave height, relative to the datum specified on the community’s legally designated flood hazard map as established by the floodplain administrator. ~~In areas designated as Zone AO, the design flood elevation shall be the elevation of the highest existing grade of the building’s perimeter plus the depth number (in feet) specified on the flood hazard map. In areas designated as Zone AO where a depth number is not specified on the map, the depth number shall be taken as being equal to 2 feet (610 mm).~~

LISTED. Equipment, materials, products or services included in a list published by an organization acceptable to the building official ~~code official~~ and concerned with evaluation of products or services that maintains periodic inspection of production of *listed equipment* or materials or periodic evaluation of services and whose listing states either that the *equipment*, material, product or service meets identified standards or has been tested and found suitable for a specified purpose.

POINT OF DELIVERY. For natural gas systems, the *point of delivery* is the outlet of the service meter assembly or the outlet of the service regulator or service shutoff valve where a meter is not provided. Where a **system shutoff** valve is provided **after** the outlet of the service meter assembly, such valve shall be considered to be downstream of the *point of delivery*. For undiluted liquefied petroleum gas systems, the point of delivery shall be considered to be the outlet of the ~~service~~ first-stage pressure regulator, ~~exclusive of line gas regulators, in the system.~~

Deleted 2021 IRC definitions

Access (To). ...*Not Adopted.*

Air, Exhaust. ...*Not adopted.*

Air, Makeup. ...*Not adopted.*

Alteration. ...*Not adopted.*

Approved. ...*Not adopted.*

Approved Agency. ...*Not adopted.*

Boiler, Low-Pressure. ...*Not adopted.*

Hot Water Heating Boiler. ...*Not adopted.*

Hot Water Supply Boiler. ...*Not adopted.*

Steam Heating Boiler. ...*Not adopted.*

Clothes Dryer. ...*Not adopted.*

Type 1. ...*Not adopted.*

Code. ...*Not adopted.*

Code Official. ...*Not adopted.*

Dwelling Unit. ...*Not adopted.*

Fireplace. ...*Not adopted.*

Factory-Built Fireplace. ...*Not adopted.*

Masonry Fireplace. ...*Not adopted.*

Flood Hazard Area. ...*Not adopted.*

Flue Collar. ...*Not adopted.*

Flue Gases. ...*Not adopted.*

Living Space. ...*Not adopted.*

Third-Party Certification Agency. ...*Not adopted.*

Third-Party Certified. ...*Not adopted.*

SECTION G2404 GENERAL

G2404.3 Listed and labeled. *Appliances* regulated by this *code* shall be *listed* and *labeled* for the application in which they are used unless otherwise *approved* in accordance with Section R104.11. The approval of unlisted *appliances* in accordance with Section R104.11 shall be based on *approved* ~~engineering~~ evaluation.

IRC G2404.6 Wind resistance. ...*Not adopted and is Reserved.*

G2404.7 Flood hazard. For structures located in flood hazard areas, as established by the flood plain administrator, the appliance, equipment and system installations regulated by this code shall be located at or above the elevation required by Section R322 for utilities and attendant equipment.

[The exception remains unchanged.]

IRC G2404.8 Seismic resistance. ...*Not adopted and is Reserved.*

SECTION G2405 STRUCTURAL SAFETY

G2405.2 Alterations to trusses. Truss members and components shall not be cut, drilled, notched, spliced or otherwise altered in any way without the ~~written concurrence and~~ approval of a ~~nonprescriptive design registered design professional~~. Alterations resulting in the addition of loads to any member, such as HVAC equipment and water heaters, shall not be permitted without verification that the truss is capable of supporting such additional loading.

G2405.3 Engineered wood products. Cuts, notches and holes bored in trusses, structural composite lumber, structural glued-laminated members and I-joists are prohibited except where permitted by the manufacturer's recommendations or where the effects of such *alterations* are specifically considered in the ~~nonprescriptive design of the member by a registered design professional~~.

SECTION G2407 COMBUSTION, VENTILATION AND DILUTION AIR

G2407.4 Makeup air provisions. Where exhaust fans, *clothes dryers* and kitchen ventilation systems interfere with the operation of *appliances, makeup air* shall be provided.

G2407.4.1 Special conditions. In buildings containing combustion appliances, equipment or fireplaces not equipped with forced or induced draft or separated from the habitable area, where an individual exhaust appliance exceeds 350 cfm (165.2 L/s), make-up air of sufficient quantity to equal that being exhausted shall be supplied to the area being ventilated. In such cases, the minimum size make-up air duct shall be 6 inches (152 mm) in diameter or equivalent area.

G2407.8 ~~Designed Engineered~~ installations. ~~Designed Engineered~~ combustion air installations shall provide an adequate supply of *combustion, ventilation and dilution air* ~~determined using approved engineering methods~~.

SECTION G2408 INSTALLATION

G2408.2 Elevation of ignition source. ~~Equipment Heating and cooling appliances, having an ignition source and water heaters covered by this code that are located in a garage and generate a glow, spark or flame capable of igniting flammable vapors shall be elevated such that the source installed with sources of ignition is not less than 18 inches (457 mm) above the floor in hazardous locations and public garages, private garages, repair garages, motor fuel dispensing facilities and parking garages. For the purpose of this section, rooms or spaces that are not part of the living space of a dwelling unit and that communicate directly with a private garage through openings shall be considered to be part of the private garage level. [The exception remains unchanged.]~~

G2408.3 Private garages. *Appliances* located in private garages shall be installed with a minimum *clearance* of 6 feet (1829 mm) above the floor.

Exception: The requirements of this section shall not apply where the *appliances* are protected from motor vehicle impact, ~~and installed in accordance with Section G2408.2. Figure M1307.3.1 contains examples of normal vehicle paths and acceptable methods of protection.~~

SECTION G2409 CLEARANCE REDUCTION

G2409.1 Scope. This section shall govern the reduction in required clearances to *combustible materials*, including gypsum board, and *combustible assemblies* for chimneys, vents, appliances, devices and equipment. Clearance requirements for air-conditioning equipment and ~~central heating boilers and~~ furnaces shall comply with Sections G2409.3 and G2409.4.

SECTION G2411 ELECTRICAL BONDING

All of G2411 is replaced with the following:

G2411.1 Gas pipe bonding. Electrical bonding of gas piping systems shall be in accordance with the *Electrical Code*.

SECTION G2412 GENERAL

G2412.1 Scope. This section shall govern the design, installation, ~~and~~ modification ~~and maintenance~~ of *pipng systems*. The applicability of this *code* to *pipng systems* extends from the *point of delivery* to the connections with the *appliances* and includes the design, materials, components, fabrication, assembly, installation, testing, ~~and~~ inspection, ~~operation and maintenance~~ of such *pipng systems*.

G2412.2 Liquefied petroleum gas storage. The storage system for *liquefied petroleum gas* ~~is not regulated by this code. shall be designed and installed in accordance with the *International Fire Code* and *NFPA 58*.~~

Notice of Installation. "Notice of Installation" is required by the State Fire Marshal for all LP-gas tank installations. For installation requirements of LP-gas tanks and tubing or piping up to the first-stage regulator, contact the office of the State Fire Marshal.

G2412.9 Identification. Each length of pipe and tubing ~~and each pipe fitting~~, utilized in a fuel gas system shall bear the identification of the manufacturer. *[The exceptions remain unchanged.]*

G2412.10 Piping materials standards. Piping, ~~and~~ tubing ~~and fittings~~ shall be manufactured to the applicable referenced standards, specifications and performance criteria listed in Section G2414 and shall be identified in accordance with Section G2412.9.

SECTION G2413 PIPE SIZING

G2413.3 Sizing. *Gas piping* shall be sized in accordance with one of the following:

1. *Pipe* sizing tables or sizing equations in accordance with Section G2413.4 or G2413.5, as applicable.
2. The sizing tables included in a *listed piping* system's manufacturer's installation instructions.
3. *Approved engineering* methods.

License requirements. LP-gas installers must be licensed by the State Fire Marshal in accordance with ORS 480.432 through 480.436.

SECTION G2414 PIPING MATERIALS

Section G2412.8.3 – New model code change

Thread joint sealants are now required for assembling threaded joints in gas piping.

G2414.8.3 Threaded joint sealing. Threaded joints shall be made using a Thread joint sealing material. Thread joint sealing materials shall be nonhardening and shall be resistant to the chemical constituents of the gases to be conveyed through the *pipng*. Thread joint sealing materials shall be compatible with the pipe and fitting materials on which the sealing materials are used.

SECTION G2415 PIPING SYSTEM INSTALLATION

Section G2415.5 – New model code change

Plugs and caps added to the list of threaded fittings approved for concealed locations.

G2415.5 Fittings in concealed locations. Fittings installed in concealed locations shall be limited to the following types:

1. Threaded elbows, tees, couplings, **plugs and caps**.
2. Brazed fittings.
3. Welded fittings.
4. Fittings *listed* to ANSI LC1/CSA 6.26 or ANSI LC4/ CSA 6.32.

Section G2415.11 – Rescinded amendment

The existing amendment has been rescinded and the model code language has been adopted.

Rescinded 2021 ORSC amendment

~~**G2415.11 Corrosion and covering protection.** Nonmetallic gas piping and coated and cathodically protected piping shall have a minimum of 18 inches (457 mm) of earth cover or other equivalent protection. Risers, including prefabricated risers inserted with plastic pipe, shall be metallic and shall be protected in an approved manner to a point at least 6 inches (163 mm) above grade. When a riser connects to plastic pipe underground, the horizontal metallic portion underground shall be at least 30 inches (762 mm) in length before connecting to the plastic service pipe. An approved transition fitting or adapter shall be used where the plastic joins the metallic riser. Ferrous metals in exposed exterior locations shall be protected from corrosion in a manner approved by the building official after consulting with the gas supplier. Ferrous pipes installed underground shall not be placed in contact with other metallic objects such as pipes or wires. Zinc coatings (galvanizing) shall not be deemed adequate protection for piping below grade. Ferrous gas piping installed underground in exterior locations shall be protected from corrosion by one of the following:~~

- ~~1. Coated and cathodically protected pipe. All gas pipe protective coatings shall be approved types, be machine applied and conform to recognized standards. Field wrapping shall provide equivalent protection and is restricted to those short sections and fittings necessarily stripped for threading or welding. Underground coated and wrapped gas piping shall be cathodically protected with galvanic anodes or rectifiers and electrically isolated from the rest of the system by insulating unions 6 inches (163 mm) above grade.~~
- ~~2. Unwrapped (bare) pipe and special covering. Unwrapped ferrous gas piping being installed underground in exterior locations shall be protected from corrosion by being installed within a minimum 6 inch (163 mm) protective bed of sand around the gas piping, the pipe being centrally located within the sand backfill, and all such horizontal piping shall have a minimum of 18 inches (457 mm) of earth cover or other equivalent protection. Underground piping shall be electrically isolated from the rest of the system by insulating unions placed a minimum of 6 inches (163 mm) above grade.~~
- ~~3. Electrical isolation of fuel gas piping. Underground ferrous gas piping shall be electrically isolated from the rest of the gas system with listed or approved isolation fittings installed a minimum of 6 inches (163 mm) above grade.~~

Adopted model code

G2415.11 Protection against corrosion. Steel pipe or tubing exposed to corrosive action, such as soil condition or moisture, shall be protected in accordance with Sections G2415.11.1 through G2415.11.4.

G2415.11.1 Galvanizing. Zinc coating shall not be deemed adequate protection for underground gas piping.

G2415.11.2 Protection methods. Underground piping shall comply with one or more of the following:

1. The piping shall be made of corrosion-resistant material that is suitable for the environment in which it will be installed.
2. Pipe shall have a factory-applied, electrically insulating coating. Fittings and joints between sections of coated pipe shall be coated in accordance with the coating manufacturer's instructions.
3. The piping shall have a cathodic protection system installed and the system shall be monitored and maintained in accordance with an approved program.

G2415.17.1 Limitations. Plastic pipe shall be installed outdoors underground only. Plastic pipe shall not be used within or under any building or [building](#) slab or be operated at pressures greater than 100 psig (689 kPa) for natural gas or 30 psig (207 kPa) for LP-gas. *[The exceptions remain unchanged.]*

SECTION G2417 INSPECTION, TESTING AND PURGING

G2417.1.1 Inspections. Inspection shall consist of visual examination, during or after manufacture, fabrication, assembly or *pressure tests*.

G2417.1.1.1 Rough piping inspection. This inspection shall be made after *piping* authorized by the permit has been installed and before such *piping* has been covered or concealed or a fixture or *appliance* has been attached thereto. This inspection shall include a determination that the gas *piping* size, material and installation meet the requirements of this chapter.

G2417.1.1.2 Final piping inspection. This inspection shall be made after *piping* authorized by the permit has been installed and after all portions thereof that are to be covered or concealed are so concealed and after fixtures, *appliances* or shutoff valves have been attached thereto.

G2417.4 Test pressure measurement. Test pressure shall be measured with a manometer or with a pressure-measuring device designed and calibrated to read, record, or indicate a pressure loss caused by leakage during the *pressure test* period. The source of pressure shall be isolated before the *pressure tests* are made. Mechanical gauges used to measure test pressures shall use a 15-pounds-per-square-inch (103 kPa) gauge or a 30-pounds-per-square-inch (206 kPa) gauge for testing 14 inches water column (3.48 kPa) systems and a 100-pounds-per-square-inch (689 kPa) gauge for testing systems exceeding 14 inches water column (3.48 kPa) operating pressure. The gauges shall not exceed the manufacturer's listing and labeling ~~have a range such that the highest end of the scale is not greater than five times the test pressure.~~

G2417.4.1 Test pressure. Gas *piping* systems under 14 inches water column (3.48 kPa) pressure shall be tested at a pressure of not less than 10 pounds per square inch (69 kPa). Test pressures shall be held for not less than 15 minutes with no perceptible drop in pressure. For welded *piping* and for *piping* carrying gas at pressures exceeding 14 inches water column (3.48 kPa) pressure, the test pressure shall be at least 60 pounds per square inch (414 kPa) for not less than 30 minutes.

Exception: Testing, inspection and purging of gas *piping* systems performed in accordance with NFPA 58.

IRC G2417.4.1 Test pressure. ...*Not adopted*

IRC G2417.4.2 Test duration. ...*Not adopted*

IRC G2417.5 Detection of leaks and defects. ...*Not adopted*

IRC G2417.6 Piping system and equipment leakage check. ...*Not adopted*

IRC G2417.7 Purging. ...*Not adopted*

SECTION G2418 PIPING SUPPORT

G2418.2 Design and installation. *Piping* shall be supported with ~~metal~~-pipe hooks, ~~metal~~-pipe straps, ~~metal~~-bands, ~~metal~~-brackets, ~~metal~~ hangers or building structural components suitable for the size of *piping*, of adequate strength and quality, and located at intervals so as to prevent or damp out excessive vibration. *[The rest of this section remains unchanged.]*

SECTION G2419 DRIPS AND SLOPED PIPING

G2419.4 Sediment trap. Where a sediment trap is not incorporated as part of the appliance, a sediment trap shall be installed downstream of the appliance shutoff valve as close to the inlet of the appliance as practical. The sediment trap shall be either a tee fitting having a capped nipple of any length installed vertically in the bottommost opening of the tee as illustrated in Figure G2419.4 or other device approved as an effective sediment trap. Illuminating appliances, ranges, clothes dryers, decorative vented appliances for installation in vented fireplaces, gas fireplaces and outdoor grills need not be so equipped unless specifically required by the appliance manufacturer's installation instructions.

SECTION G2421 FLOW CONTROLS

G2421.3 Liquefied petroleum gas regulators. LP-gas second-stage and 2-pounds-per-square-inch (13.8 kPa) regulators, as defined by NFPA 58, shall be installed in accordance with the following:

1. Regulators installed outdoors shall be protected from motor vehicle impact. For examples of *approved* types of protection, see Figure M1307.1.
2. Regulator vent discharge shall be located not less than 3 feet (914 mm) horizontally from openings below the point of discharge and not less than 5 feet (1524 mm) in any direction from exterior sources of ignition, openings into direct-vent appliances or mechanical ventilation air intakes.
3. Venting of regulators shall comply with Sections G2421.4 and G2421.4.1.

G2421.4.1 ~~G2421.3.1~~ Vent piping. Vent piping for relief vents and breather vents shall be constructed of materials allowed for gas piping in accordance with Section G2414. Vent piping shall be not smaller than the vent connection on the pressure -regulating device. Vent piping serving relief vents and combination relief and breather vents shall be run independently to the outdoors and shall serve only a single device vent. ~~Vent piping serving only breather vents is permitted to be connected in a manifold arrangement where sized in accordance with an approved design that minimizes backpressure in the event of diaphragm rupture.~~ Regulator vent piping shall not exceed the length specified in the regulator manufacturer's instructions.

SECTION G2422 APPLIANCE CONNECTIONS

G2422.1 Connecting appliances. Appliances shall be connected to the piping system by one of the following: *[Items 1 through 6 remain unchanged.]*

- ~~7. Listed outdoor gas hose connectors in compliance with ANSI Z21.54 used to connect portable outdoor appliances. The gas hose connection shall be made only in the outdoor area where the appliance is used, and shall be to the gas piping supply at an appliance shutoff valve, a listed quick disconnect device or listed gas convenience outlet.~~

SECTION G2425 GENERAL

G2425.1 Scope. This section shall govern the installation, ~~maintenance~~, repair and approval of factory-built chimneys, chimney liners, vents and connectors and the utilization of masonry chimneys serving gas-fired appliances.

SECTION G2427 VENTING OF APPLIANCES

G2427.5 Masonry, ~~metal~~ and factory-built chimneys. Masonry, ~~metal~~ and factory-built chimneys shall comply with Sections G2427.5.1 through G2427.5.10.

G2427.5.2 Masonry chimneys. Masonry chimneys shall be built and installed in accordance with ~~NFPA 211~~ Chapter 10 and shall be lined with an approved clay flue lining, a chimney lining system listed and labeled in accordance with UL 1777 or other approved material that will resist corrosion, erosion, softening or cracking from vent gases at temperatures up to 1,800°F (982°C). *[The exceptions remain unchanged.]*

G2427.5.3 Chimney termination. Chimneys for residential-type or low-heat appliances shall extend not less than 3 feet (914 mm) above the highest point where they pass through a roof of a building and not less than 2 feet (610 mm) higher than any portion of a building within a horizontal distance of 10 feet (3048 mm) (see Figure G2427.5.3). Chimneys for medium-heat appliances shall extend not less than 10 feet (3048 mm) higher than any portion of any building within 25 feet (7620 mm). Chimneys shall extend not less than 5 feet (1524 mm) above the highest connected appliance draft hood outlet or flue collar. Decorative shrouds shall not be installed at the termination of factory-built chimneys except where such shrouds are listed and labeled for use with the specific factory-built chimney system and are installed in accordance with the manufacturer's instructions.

G2427.5.4 Size of chimneys. The effective area of a *chimney* venting system serving *listed appliances* with *draft hoods*, Category I *appliances*, and other *appliances listed* for use with Type B vents shall be determined in accordance with one of the following methods:

[Items 1 through 3 remain unchanged.]

4. *Chimney venting systems* using *mechanical draft* shall be sized in accordance with *approved engineering* methods.
5. Other *approved engineering* methods.

G2427.5.5.1 Chimney lining. *Chimneys* shall be lined in accordance with ~~NFPA 211~~ [Chapter 10](#).

G2427.5.5.2 Cleanouts. Cleanouts shall be ~~examined and where they do not remain tightly closed when not in use, they shall be repaired or replaced~~ [installed in accordance with Chapter 10](#).

G2427.5.5.3 Unsafe chimneys. Where inspection reveals that an existing *chimney* is not safe for the intended application, it shall be repaired, rebuilt, lined, relined or replaced with a vent or *chimney* to conform to ~~NFPA 211~~ [Chapter 10](#) and it shall be suitable for the *appliances* to be vented.

IRC G2427.5.6.2 Liquid fuel-burning appliances. *...Not adopted.*

[G2427.5.6.2 Common venting of gas utilization equipment and liquid fuel-burning appliances.](#) [The common venting of gas utilization equipment and liquid fuel-burning appliances shall comply with Sections M1804.3.2 and M1804.3.2.1.](#)

G2427.6.9.1 Category I appliances. The sizing of *natural draft venting systems* serving one or more *listed appliances* equipped with a *draft hood* or *appliances listed* for use with Type B gas vent, installed in a single story of a building, shall be in accordance with one of the following methods:

[Items 1 through 3 remain unchanged.]

4. *Approved engineering* methods.

G2427.6.9.4 Mechanical draft. *Chimney venting systems* using *mechanical draft* shall be sized in accordance with *approved engineering* methods.

G2427.7.9 Size of single-wall metal pipe. A venting system constructed of single-wall metal pipe shall be sized in accordance with one of the following methods and the *appliance* manufacturer's instructions: *[Items 1 and 2 remain unchanged.]*

3. *Approved engineering* methods.

G2427.10.2.2 Vent connectors located in unconditioned areas. Where the *vent connector* used for an *appliance* having a *draft hood* or a Category I *appliance* is located in or passes through attics, crawl spaces or other unconditioned spaces, that portion of the *vent connector* shall be *listed* Type B, Type L or listed vent material having equivalent insulation properties.

Exception: Single-wall metal pipe located within the exterior walls of the building in areas having a local 99-percent winter design temperature of 5°F (-15°C) or higher shall be permitted to be used in unconditioned spaces other than attics, [garages](#) and crawl spaces.

G2427.10.3.1 Single draft hood and fan-assisted. A *vent connector* for an *appliance* with a single *draft hood* or for a Category I fan-assisted *combustion system appliance* shall be sized and installed in accordance with Section G2428 or *approved engineering* methods.

G2427.10.3.2 Multiple draft hood. ~~Where~~ a single *appliance* having more than one *draft hood* outlet or *flue collar* ~~is installed~~, the manifold shall be constructed according to the instructions of the *appliance* manufacturer. Where there are no instructions, the manifold shall be designed and constructed in accordance with *approved engineering* methods. As an alternate method, the effective area of the manifold shall equal the combined area of the *flue collars* or *draft hood* outlets and the *vent connectors* shall have a ~~rise of not less than 12 inches~~ (305 mm).

G2427.10.3.3 Multiple appliances. Where two or more *appliances* are connected to a common *vent* or *chimney*, each *vent connector* shall be sized in accordance with Section G2428 or *approved engineering* methods.

As an alternative method applicable only where all of the *appliances* are *draft hood* equipped, each *vent connector* shall have an effective area not less than the area of the *draft hood* outlet of the *appliance* to which it is connected.

G2427.10.9 Length of vent connector. The maximum horizontal length of a single-wall connector shall be 75 percent of the height of the *chimney* or vent ~~except for engineered systems unless otherwise approved~~. The maximum horizontal length of a Type B double-wall connector shall be 100 percent of the height of the *chimney* or vent ~~except for engineered systems unless otherwise approved~~.

G2427.15 Obstructions. Devices that retard the flow of *vent gases* shall not be installed in a *vent connector*, *chimney* or vent. The following shall not be considered as obstructions:

1. *Draft regulators* and *safety controls* specifically listed for installation in *venting systems* and installed in accordance with the manufacturer's instructions.
 2. *Approved draft regulators* and *safety controls* that are designed and installed in accordance with *approved engineering* methods.
 3. Listed heat reclaimers and automatically operated vent dampers installed in accordance with the manufacturer's instructions.
 4. *Approved economizers*, heat reclaimers and recuperators installed in *venting systems of appliances* not required to be equipped with *draft hoods*, provided that the *appliance* manufacturer's instructions cover the installation of such a device in the venting system and performance in accordance with Sections G2427.3 and G2427.3.1 is obtained.
 5. Vent dampers serving *listed appliances* installed in accordance with Sections G2428.2.1 and G2428.3.1 or *approved engineering* methods.
-

SECTION G2428 SIZING OF CATEGORY I APPLIANCE VENTING SYSTEMS

G2428.2.8 Vent area and diameter. Where the vertical vent has a larger diameter than the *vent connector*, the vertical vent diameter shall be used to determine the minimum vent capacity, and the connector diameter shall be used to determine the maximum vent capacity. The flow area of the vertical vent shall not exceed seven times the flow area of the listed *appliance* categorized vent area, *flue collar* area, or *draft hood* outlet area unless designed in accordance with *approved engineering* methods.

G2428.2.9 Chimney and vent locations. Tables G2428.2(1) and G2428.2(2) shall be used only for chimneys and vents not exposed to the outdoors below the roof line. A Type B vent or listed chimney lining system passing through an unused masonry chimney flue shall not be considered to be exposed to the outdoors. Where vents extend outdoors above the roof more than 5 feet (1524 mm) higher than required by Figure G2427.6.4, and where vents terminate in accordance with Section G2427.6.4, Item 2, the outdoor portion of the vent shall be enclosed as required by this section for vents not considered to be exposed to the outdoors or such venting system shall be an approved design-engineered. A Type B vent shall not be considered to be exposed to the outdoors where it passes through an unventilated enclosure or chase insulated to a value of not less than R-8.

G2428.2.16 Engineering-Design calculations. Where a vent height is less than 6 feet (1829 mm) or greater than shown in the tables, an engineering-approved method shall be used to calculate the vent capacity.

G2428.3.13 Vertical vent maximum size. Where two or more *appliances* are connected to a vertical vent or *chimney*, the flow area of the largest section of vertical vent or *chimney* shall not exceed seven times the smallest listed *appliance* categorized vent areas, *flue collar* area, or *draft hood* outlet area unless designed in accordance with *approved engineering* methods.

G2428.3.16 Chimney and vent location. Tables G2428.3(1), G2428.3(2), G2428.3(3) and G2428.3(4) shall be used only for chimneys and vents not exposed to the outdoors below the roof line. A Type B vent or *listed* chimney lining system passing through an unused masonry chimney flue shall not be considered to be exposed to the outdoors. Where vents extend outdoors above the roof more than 5 feet (1524 mm) higher than required by Figure G2427.6.4 and where vents terminate in accordance with Section G2427.6.4, Item 2, the outdoor portion of the vent shall be enclosed as required by this section for vents not considered to be exposed to the outdoors or such venting system shall be an approved design-engineered. A Type B vent shall not be considered to be exposed to the outdoors where it passes through an unventilated enclosure or chase insulated to a value of not less than R-8.

G2428.3.23 Engineering-Design calculations. For *vent* heights less than 6 feet (1829 mm) and greater than shown in the tables, ~~engineering-an approved design~~ methods shall be used to calculate *vent* capacities.

SECTION G2431 GENERAL

G2431.1 Scope. Sections G2432 through G2453 shall govern the approval, design, installation, construction, ~~maintenance, alteration~~ and repair of the *appliances* and *equipment* specifically identified herein.

SECTION G2433 LOG LIGHTERS

G2433.1 General. Log lighters shall be ~~listed in accordance with CSA 8 and shall be~~ installed in accordance with the manufacturer's instructions.

SECTION G2438 CLOTHES DRYERS

G2438.1 General. ~~Clothes dryers shall be listed in accordance with ANSI Z21.5.1/CSA 7.1 and shall be installed in accordance with the manufacturer's instructions.~~ Clothes dryers shall comply with Section M1502.

SECTION G2439 CLOTHES DRYER EXHAUST

Section G2439 is not adopted and is Reserved.

SECTION G2440 SAUNA HEATERS

G2440.1 General. Sauna heaters shall be installed in accordance with the manufacturer's instructions, this section and Section M1902.

IRC G2440.2 Location and protection. *...Not adopted.*

IRC G2440.2.1 Guards. *...Not adopted.*

IRC G2440.3 Access. *...Not adopted.*

IRC G2440.6 Heat and time controls. *...Not adopted.*

IRC G2440.6.1 Timers. *...Not adopted.*

IRC G2440.7 Sauna room. *...Not adopted.*

SECTION G2442 FORCED-AIR WARM-AIR FURNACES

G2442.2 Forced-air furnaces. The minimum unobstructed total area of the outside and return air ducts or openings to a forced-air warm-air furnace shall be not less than 2 square inches (1290 mm²) for each 1,000 Btu/h (4402 mm²/W) output rating capacity of the furnace and not less than that specified in the furnace manufacturer's installation instructions. The minimum unobstructed total area of supply ducts from a forced-air warm-air furnace shall be not less than 2 square inches for each 1,000 Btu/h (4402 mm²/W) output rating capacity of the furnace and not less than that specified in the furnace manufacturer's installation instructions.

Exception: The total area of the supply air ducts and outside and return air ducts shall not be required to be larger than the minimum size required by the furnace manufacturer's installation instructions.

G2442.4 ~~G2442.3~~ Prohibited sources. Outdoor or return air for forced-air heating and cooling systems shall not be taken from the following locations:

[Items 1 through 7 remain unchanged.]

7. A crawl space by means of direct connection to the return side of a forced-air system. ~~Transfer openings in the crawl space enclosure shall not be prohibited.~~

SECTION G2448 WATER HEATERS

G2448.1 General. Water heaters shall be *listed* in accordance with ANSI Z21.10.1/CSA 4.1 *or* ANSI Z21.10.3/CSA 4.3 and shall be installed in accordance with the manufacturer's instructions and the *Plumbing Code*.

G2448.1.1 Installation requirements. The requirements for *water heaters* relative to sizing, *relief valves*, drain pans and scald protection shall be in accordance with ~~this~~ the *Plumbing Code*.

G2448.2 Water heaters utilized for space heating. *Water heaters* utilized both to supply potable hot water and provide hot water for space-heating applications shall be *listed* and *labeled* for such applications by the manufacturer and shall be installed in accordance with the manufacturer's instructions, Section M2005 and ~~this~~ the *Plumbing Code*.

SECTION G2452 BOILERS

Section G2452 is not adopted and in Reserved.

Appendices

APPENDIX AA SIZING AND CAPACITIES OF GAS PIPING

Appendix AA of the 2021 International Residential Code is not adopted by the State of Oregon, Building Codes Division, as part of this code. The subject matter in this appendix is preempted by the provisions of the state building code and may not be adopted by a municipality.

[The rest of Appendix AA is deleted in its entirety.]

APPENDIX AB SIZING OF VENTING SYSTEMS SERVING APPLIANCES EQUIPPED WITH DRAFT HOODS, CATEGORY I APPLIANCES AND APPLIANCES LISTED FOR USE WITH TYPE B VENTS

Appendix AB of the 2021 International Residential Code is not adopted by the State of Oregon, Building Codes Division, as part of this code. The subject matter in this appendix is preempted by the provisions of the state building code and may not be adopted by a municipality.

[The rest of Appendix AB is deleted in its entirety.]

APPENDIX AC RESERVED

APPENDIX AD RECOMMENDED PROCEDURE FOR SAFETY INSPECTION OF AN EXISTING APPLIANCE INSTALLATION

Appendix AD of the 2021 International Residential Code is not adopted by the State of Oregon, Building Codes Division, as part of this code. The subject matter in this appendix is preempted by the provisions of the state building code and may not be adopted by a municipality.

[The rest of Appendix AD is deleted in its entirety.]

APPENDIX AE MANUFACTURED HOUSING USED AS DWELLINGS

[Section AE101 through AE124 are not adopted and are deleted.]

SECTION ~~AE124~~ AE101 ANCHORAGE INSTALLATIONS

AE101.1 ~~AE124.1~~ Ground anchors. ...*Renumbered.*

AE101.2 ~~AE124.2~~ **Anchoring equipment.** Anchoring equipment, where installed as a permanent installation, shall be capable of resisting all loads as specified within these provisions. Where the stabilizing system is designed in accordance with Section R301.1.3 ~~by an engineer or architect licensed by the state to practice~~, such ~~alternative~~ designs shall include anchoring equipment capable of withstanding a load equal to 1.5 times the calculated load. Anchoring equipment shall be *listed* and *labeled* as being capable of meeting the requirements of these provisions. Anchors as specified in this code shall be attached to the main frame of the *manufactured home* by an *approved* ^{3/16}-inch-thick (4.76 mm) slotted steel plate anchoring device. Other anchoring devices or methods meeting the requirements of these provisions shall be subject to the evaluation and *approval* of the *building official*.

Anchoring systems shall be so installed as to be permanent. Anchoring equipment shall be so designed to prevent self-disconnection with no hook ends used.

AE101.3 ~~AE124.3~~ Resistance to weather deterioration. ...*Renumbered.*

AE101.4 ~~AE124.4~~ Tensioning devices. ...*Renumbered.*

SECTION ~~AE125~~ AE102 TIES, MATERIALS AND INSTALLATION

AE102.1 ~~AE125.1~~ General. ...*Renumbered.*

SECTION AE126 REFERENCED STANDARDS

[Section AE126 is not adopted and is deleted.]

APPENDIX AF RADON CONTROL METHODS

SECTION AF101 SCOPE

AF101.1 General. This appendix contains requirements for new construction in [Baker, Clackamas, Hood River, Multnomah, Polk, Washington, and Yamhill counties](#) ~~jurisdictions~~ where radon-~~mitigating resistant~~ construction is required.

[ORS 455.365](#) is not part of this code, but is reprinted here for the reader's convenience.

455.365 Radon mitigation standards.

(1) [The Building Codes Structures Board and the Residential and Manufactured Structures Board shall adopt design and construction standards for mitigating radon levels in new residential buildings that are identified under the structural specialty code as Group R-2 or R-3 buildings and new public buildings. In adopting the standards, the boards shall give consideration to any standards recommended by the United States Environmental Protection Agency for radon mitigation systems in buildings.](#)

(2) [The boards shall make the design and construction standards for mitigating radon levels applicable in:](#)

(a) [Baker, Clackamas, Hood River, Multnomah, Polk, Washington and Yamhill Counties; and](#)

(b) [Any county for which the boards, after consultation with the Oregon Health Authority, consider the standards appropriate due to local radon levels.](#)

(3) [The Director of the Department of Consumer and Business Services may authorize a municipality that administers and enforces one or more building inspection programs under ORS 455.148 or 455.150 to also administer and enforce any applicable standards for mitigating radon that are adopted by the boards.](#)

(4) [The director, in consultation with the boards, may adopt rules for the implementation, administration and enforcement of this section.](#)

~~Inclusion of this appendix by *jurisdictions* shall be determined through the use of locally available data or determination of Zone 1 designation in Figure AF101.1 and Table AF101.1.~~

SECTION AF102 DEFINITIONS

AF102.1 General. For the purpose of these requirements, the terms used shall be defined as follows:

GEOTEXTILE DRAIN MATTING. A product suitable for soil contact that provides a void space laterally through the material to allow air movement. The void space is created through a matrix of woven mesh, "egg crate" support of a fabric enclosure or similar means. Also known as soil gas collector matting, geotextile vent strip or vapor matting.

SOIL-GAS COLLECTOR. A gas-permeable conduit constructed of gravel, perforated pipe or geotextile drain matting for collecting radon gases from within a soil-gas collection plenum and connecting the plenum to a vertical vent pipe system.

SECTION AF103 REQUIREMENTS

AF103.1 General. The following construction techniques are intended to resist radon entry ~~in new residential construction and prepare the building for post construction radon mitigation, if necessary (see Figure AF103.1).~~ These techniques are required in areas where designated ~~in Section AF101.1 by the jurisdiction.~~ See Figures AF103(1), AF103(2) and AF103(3).

Figure AF101.1 EPA Map of Radon Zones. *...Not adopted.*

Table AF101.1 High Radon-Potential (Zone 1) Counties. *...Not adopted.*

Figure AF103.1 Radon-Resistant Construction Details for Four Foundation Types. *...Not adopted.*

AF103.4.8 Ducts. Ductwork passing through or beneath a slab shall be of seamless material unless the air-handling system is designed to maintain continuous positive pressure within such ducting. Joints in such ductwork shall be sealed to prevent air leakage.

Ductwork located in crawl spaces shall have seams and joints sealed by closure systems in accordance with Section M1601.4.1. Where fan systems circulate air to living spaces, all ductwork located in the crawl space shall be positive-pressure ductwork.

(Errata issued April 2024)

AF103.5 ~~Passive submembrane depressurization system~~ Crawl space mitigation system. In buildings with *crawl space* foundations, ~~the following components of a passive submembrane depressurization~~ a system complying with Section AF103.5.1 or AF103.5.2 shall be installed during construction.

Exception: Buildings in which an *approved* mechanical *crawl space* ventilation system or other equivalent system is installed.

AF103.5.1 Passive submembrane depressurization system.

AF103.5.1.1 ~~AF103.5.1~~ Ventilation. Crawl spaces shall be provided with vents to the exterior of the building. The minimum net area of ventilation openings shall comply with Section R408.1.

AF103.5.1.2 ~~AF103.5.2~~ Soil-gas-retarder. The soil in crawl spaces shall be covered with a continuous layer of minimum 6 mil (0.15 mm) polyethylene soil-gas-retarder. The ground cover shall be lapped not less than 12 inches (305 mm) at joints and shall extend to all foundation walls enclosing the *crawl space* area.

AF103.5.1.3 ~~AF103.5.3~~ Vent pipe. A vertical vent pipe of not less than 3 inches (76 mm) in diameter shall be installed through the soil-gas-retarder and connected to the soil-gas collector with a plumbing tee or other approved connection ~~shall be inserted horizontally beneath the sheeting and connected to a 3- or 4-inch diameter (76 or 102 mm) fitting with a vertical vent pipe installed through the sheeting.~~ The vent pipe shall be extended up through the building floors, and terminate not less than 12 inches (305 mm) above the roof in a location not less than 10 feet (3048 mm) away from any window or other opening into the *conditioned spaces* of the building that is less than 2 feet (610 mm) below the exhaust point, and 10 feet (3048 mm) from any window or other opening in adjoining or adjacent buildings.

AF103.5.1.3.1 Soil-gas collector. Not less than one soil-gas collector shall be installed in accordance with Section AF103.5.1.3.1.1, AF103.5.1.3.1.2 or AF103.5.1.3.1.3 and shall be connected to the vent pipe required by Section AF103.5.1.3.

AF103.5.1.3.1.1 Pipe soil-gas collector. The soil-gas collector shall consist of not less than a 3-inch diameter (76 mm) perforated pipe. The pipe shall be not less than 10 feet (3048 mm) in total length, with not less than 5 feet (1524 mm) of perforated pipe extending from the point of connection to the vertical vent pipe. Such pipe shall be placed in a trench backfilled with clean aggregate meeting the criteria of Section AF103.2, Item 1 such that the pipe is completely surrounded by not less than 4 inches (102 mm) of aggregate.

AF103.5.1.3.1.2 Geotextile soil-gas collector. The soil-gas collector shall consist of a strip of geotextile drain matting not less than 10 feet (3048 mm) in length and having a cross sectional area of not less than 12 square inches (7742 mm²). The strip of matting shall be placed on top of the soil or in a trench.

AF103.5.1.3.1.3 Gravel soil-gas collector. The soil-gas collector shall consist of a uniform layer of clean aggregate meeting the criteria of Section AF103.2, Item 1 not less than 4 inches (102 mm) in depth placed over the soil.

AF103.5.2 Crawl space ventilation and building tightness.

AF103.5.2.1 Ventilation. Crawl spaces shall be provided with vents to the exterior of the building that comply with Section R408 of this code. The minimum net area of ventilation openings shall be not less than 1 square foot (0.0929 m²) for each 150 square feet (14 m²) of underfloor space area.

AF103.5.2.2 Ventilation openings. Ventilation openings shall comply with Section R408.2. Operable louvers, dampers or other means to temporarily stop the ventilation shall not be permitted.

AF103.5.2.3 Building tightness. Dwellings shall be tested with a blower door, depressurizing the dwelling to 50 Pascals from ambient conditions and found to exhibit not more than 4.0 air changes per hour. A mechanical exhaust, supply or combination ventilation system providing whole-building ventilation rates specified in Section M1505.4.3 or ASHRAE 62.2 shall be installed within the dwelling unit.

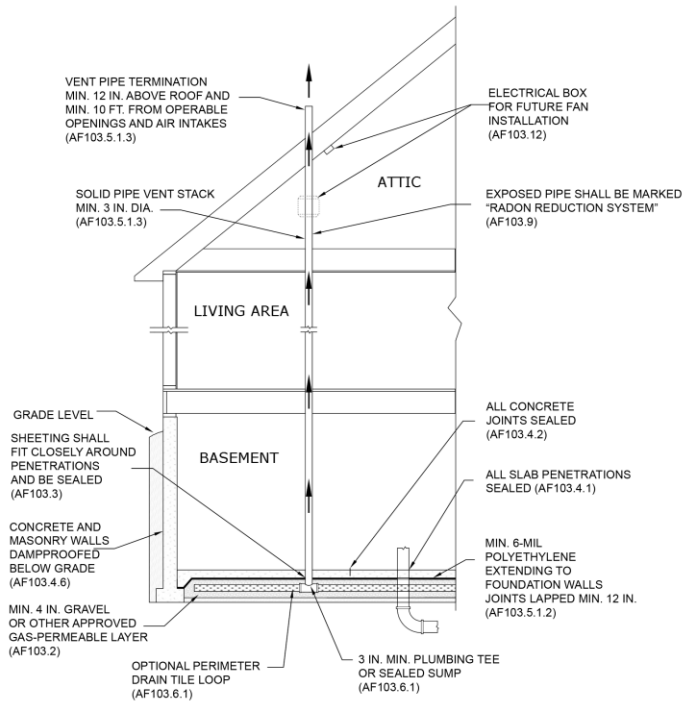

FIGURE AF103(1)
RADON-RESISTANT CONSTRUCTION DETAILS FOR BASEMENT FOUNDATIONS

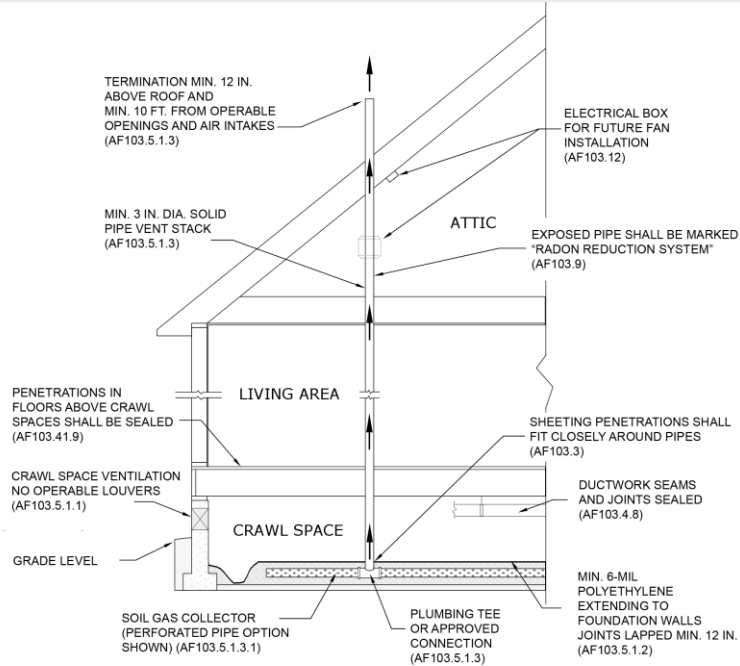

FIGURE AF103(2)
RADON-RESISTANT CONSTRUCTION FOR CRAWL SPACE FOUNDATIONS

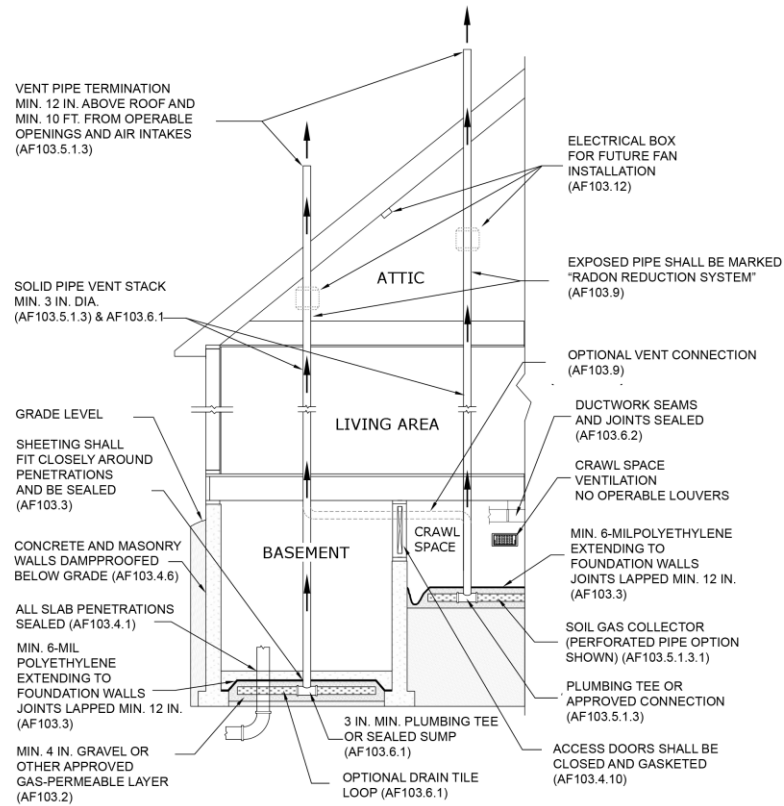

FIGURE AF103(3)
RADON-RESISTANT CONSTRUCTION FOR COMBINATION BASEMENT/CRAWL SPACE FOUNDATIONS

SECTION AF104 TESTING *Section AF104 is not adopted and is deleted.*

APPENDIX AG
PIPING STANDARDS FOR VARIOUS APPLICATIONS

Appendix AG of the 2021 International Residential Code is not adopted by the State of Oregon, Building Codes Division, as part of this code. The subject matter in this appendix is preempted by the provisions of the state building code and may not be adopted by a municipality.

[The rest of Appendix AG is deleted in its entirety.]

APPENDIX AH

DECK, PATIO OR PORCH COVERS

SECTION AH101 GENERAL

AH101.1 Scope. Deck, patio or porch covers more than 200 square feet (18.5 m²) in building area shall conform to the requirements of Sections AH101 through AH105.

AH101.2 Permitted uses. Deck, patio or porch covers detached from or attached to *dwelling units* shall be used only for recreational, outdoor living purposes, and not as carports, garages, storage rooms or habitable rooms.

SECTION AH102 DEFINITION

AH102.1 General. The following word and term shall, for the purposes of this appendix, have the meaning shown herein.

DECK, PATIO OR PORCH COVER. A one-story structure, not exceeding 12 feet (3657 mm) in mean roof height, with open or glazed walls, as prescribed in this appendix, that is used for recreational, outdoor living purposes associated with a *dwelling unit*.

SECTION AH103 EXTERIOR WALLS AND OPENINGS

AH103.1 Enclosure walls. Exterior enclosure walls shall be permitted to be of any configuration, provided that the open or glazed area of the longer wall and one additional wall is not less than 65 percent of the area below 6 feet 8 inches (2032 mm) of each wall, measured from the floor. Openings shall be enclosed with any of the following:

1. Insect screening.
2. *Approved* translucent or transparent plastic not more than 0.125 inch (3.2 mm) in thickness.
3. Glass conforming to the provisions of Section R308.
4. Any combination of the foregoing.

AH103.2 Light, ventilation and emergency egress. Exterior openings required for light and ventilation into a patio structure conforming to Section AH101 shall be unenclosed where such openings serve as emergency egress or rescue openings from sleeping rooms. Where such exterior openings serve as an exit from the *dwelling unit*, the deck, patio or porch structure, unless unenclosed, shall be provided with exits conforming to the provisions of Section R311.

SECTION AH104 HEIGHT

AH104.1 Height. Deck, patio or porch covers are limited to one-story structures not exceeding 12 feet (3657 mm) in height.

SECTION AH105 STRUCTURAL PROVISIONS

AH105.1 Design loads. Deck, patio or porch covers shall be designed and constructed to sustain, within the stress limits of this code, all dead loads plus a vertical *live load* of not less than 10 pounds per square foot (0.48 kN/m²), except that snow loads shall be used where such snow loads exceed this minimum. Such covers shall be designed to resist the minimum wind loads set forth in Section R301.2.1.

AH105.2 Footings. In areas with a frostline depth of zero as specified in Table R301.2, for deck, patio or porch covers supported on a slab-on-grade without footings, the slab shall conform to the provisions of Section R506, shall be not less than 3.5 inches (89 mm) thick and the columns shall not support live and dead loads in excess of 750 pounds (3.34 kN) per column.

SECTION AH106 SPECIAL PROVISIONS FOR ... *[Section AH106 is not adopted and is deleted.]*

APPENDIX AI PRIVATE SEWAGE DISPOSAL

Appendix AI of the 2021 International Residential Code is not adopted by the State of Oregon, Building Codes Division, as part of this code. The subject matter in this appendix is preempted by the provisions of the state building code and may not be adopted by a municipality.

*[*The rest of Appendix AI is deleted in its entirety.]*

APPENDIX AJ EXISTING BUILDINGS AND STRUCTURES

Appendix AJ of the 2021 International Residential Code is not adopted by the State of Oregon, Building Codes Division, as part of this code. The subject matter in this appendix is preempted by the provisions of the state building code and may not be adopted by a municipality.

*[*The rest of Appendix AJ is deleted in its entirety.]*

APPENDIX AK SOUND TRANSMISSION

SECTION AK102 AIRBORNE SOUND

AK102.1 General. Airborne sound insulation for wall and floor-ceiling assemblies shall meet a sound transmission class (STC) rating of 45 when tested in accordance with ASTM E90 or a Normalized Noise Isolation Class (NNIC) rating of 42 when tested in accordance with ASTM E336. ~~Penetrations or openings in construction assemblies for piping; electrical devices; recessed cabinets; bathtubs; soffits; or heating, ventilating or exhaust ducts shall be sealed, lined, insulated or otherwise treated to maintain the required ratings. Dwelling unit entrance doors, which share a common space, shall be tight fitting to the frame and sill.~~

AK102.1.1 Masonry. ...*Not adopted.*

SECTION AK104

**TABLE AK104.1
REFERENCED STANDARDS**

STANDARD ACRONYM	STANDARD NAME	SECTIONS HEREIN REFERENCED
ASTM E90—09	<i>Test Method for Laboratory Measurement of Airborne Sound Transmission Loss of Building Partitions and Elements</i>	AK102.1, AK102.1.1
TMS 0302—12	Standard for Determining the Sound Transmission Class Rating for Masonry Walls	AK102.1.1

*[*The parts of the table not shown here remain unchanged.]*

APPENDIX AL PERMIT FEES

Appendix AL of the 2021 International Residential Code is not adopted by the State of Oregon, Building Codes Division, as part of this code. The subject matter in this appendix is preempted by the provisions of the state building code and may not be adopted by a municipality.

*[*The rest of Appendix AL is deleted in its entirety.]*

APPENDIX AM HOME DAY CARE—R-3 OCCUPANCY

Appendix AM of the 2021 International Residential Code is not adopted by the State of Oregon, Building Codes Division, as part of this code. The subject matter in this appendix is preempted by the provisions of the state building code and may not be adopted by a municipality.

*[*The rest of Appendix AM is deleted in its entirety.]*

APPENDIX AN VENTING METHODS

Appendix AN of the 2021 International Residential Code is not adopted by the State of Oregon, Building Codes Division, as part of this code. The subject matter in this appendix is preempted by the provisions of the state building code and may not be adopted by a municipality.

*[*The rest of Appendix AN is deleted in its entirety.]*

APPENDIX AO AUTOMATIC VEHICULAR GATES

Appendix AO of the 2021 International Residential Code is not adopted by the State of Oregon, Building Codes Division, as part of this code. The subject matter in this appendix is preempted by the provisions of the state building code and may not be adopted by a municipality.

*[*The rest of Appendix AO is deleted in its entirety.]*

APPENDIX AP SIZING OF WATER PIPING SYSTEM

Appendix AP of the 2021 International Residential Code is not adopted by the State of Oregon, Building Codes Division, as part of this code. The subject matter in this appendix is preempted by the provisions of the state building code and may not be adopted by a municipality.

*[*The rest of Appendix AP is deleted in its entirety.]*

APPENDIX AQ TINY HOUSES

Appendix AQ of the 2021 International Residential Code is not adopted by the State of Oregon, Building Codes Division, as part of this code. For detached one-family dwellings not more than 400 square feet in size, Oregon Revised Statute (ORS) Chapter 455 requires application of the Small Home Specialty Code. See ORS 455 and Enrolled House Bill 2423 from Oregon's Legislative Assembly 2019 Regular Session.

*[*The rest of Appendix AQ is deleted in its entirety.]*

APPENDIX AR LIGHT STRAW-CLAY CONSTRUCTION

SECTION AR101 GENERAL

AR101.1 Scope. This appendix shall govern the use of light straw-clay as a nonbearing building material and wall infill system in *Seismic Design Categories A and B*. Use of light straw-clay in *Seismic Design Categories C, D₀, D₁ and D₂* shall require an *approved* ~~engineered~~ design [in accordance with Section R301.1.3](#) ~~by a registered design professional~~ in accordance with Section R301.1.3.

SECTION AR103 NONBEARING LIGHT STRAW-CLAY CONSTRUCTION

AR103.2 Structure. The structure of buildings using light straw-clay shall be in accordance with the *Residential Code* or shall be in accordance with an *approved* design [in accordance with Section R301.1.3](#) ~~by a registered design professional~~.

AR103.2.1 Number of stories. Use of light straw-clay infill shall be limited to buildings that are not more than one *story above grade plane*.

Exception: Buildings using light straw-clay infill that are greater than one *story above grade plane* shall be in accordance with an *approved* design [in accordance with Section R301.1.3](#) ~~by a registered design professional~~.

AR103.2.4 Stabilization of light straw-clay. Light straw-clay shall be stabilized as follows, or shall be in accordance with an *approved* design [in accordance with Section R301.1.3](#) ~~by a registered design professional~~.

1. Vertical stabilization shall be of structural or nonstructural wood framing in accordance with Figure AR103.2.4(1), AR103.2.4(2) or AR103.2.4(3). Framing members that are both load-bearing and stabilization members shall meet the requirements of Section R602 and this section. Nonstructural stabilization members shall be not more than 32 inches (813 mm) on center.
 2. Horizontal stabilization shall be installed at not more than 24 inches (610 mm) on center and in accordance with Figure AR103.2.4(1), AR103.2.4(2) or AR103.2.4(3). Horizontal stabilization shall be of any of the following with the stated minimum dimensions: $\frac{3}{4}$ -inch (19.1 mm) bamboo, $\frac{1}{2}$ -inch (12.7 mm) fiberglass rod, 1-inch (25 mm) wood dowel or nominal 1-inch by 2-inch (25 mm by 51 mm) wood.
-

APPENDIX AS STRAWBALE CONSTRUCTION

SECTION AS102 DEFINITIONS

AS104.1.1 Exterior wall finishes. Exterior wall finishes shall be plasters in accordance with Section AS104.4, or nonplaster exterior wall coverings in accordance with Section R703 and other finish systems complying with all of the following:

1. With *approved* specifications and details showing the finish system's means of attachment to the wall or its independent support, and a means of draining or evaporating water that penetrates the exterior finish to the exterior.
 2. The vapor permeance of the combination of finish materials shall be 5 perms or greater to allow the transpiration of water vapor through the wall.
 3. Finish systems with weights greater than 10 or less than or equal to 20 pounds per square foot (> 48.9 and ≤ 97.8 kg/m) of wall area require a factor of 1.2 for minimum total length of braced wall panels in Table AS106.13(3).
 4. Finish systems with weights greater than 20 pounds per square foot (97.8 kg/m) of wall area require [a design in accordance with Section R301.1.3](#) ~~an engineered design~~.
-

SECTION AS105 STRAWBALE WALLS—GENERAL

AS105.2 Building limitations and requirements for use of strawbale nonstructural walls. *Buildings* using *strawbale nonstructural walls* shall be subject to the following limitations and requirements:

1. Number of stories: not more than one, except that two stories shall be allowed with an *approved* [design in accordance with Section R301.1.3](#) ~~engineered design~~.
 2. *Building* height: not more than 25 feet (7620 mm), except that greater heights shall be allowed with an *approved* [design in accordance with Section R301.1.3](#) ~~engineered design~~.
 3. Wall height: in accordance with Table AS105.4.
 4. Braced wall panel lengths: in accordance with Section R602.10.3, with the additional requirements that Table R602.10.3(3) shall apply to all *buildings* in *Seismic Design Category C*, and the minimum total length of braced wall panels in Table R602.10.3(3) shall be increased by 60 percent for *buildings* in *Seismic Design Categories C, D₀, D₁ and D₂*.
-

AS105.4.1 Determination of out-of-plane loading. Out-of-plane loading for the use of Table AS105.4 shall be in terms of the ~~ultimate-basic~~ design wind speed and seismic design category as determined in accordance with Sections R301.2.1 and R301.2.2. ~~An engineered design in accordance with Section R301.2.1 shall be required where the building is located in a special wind region or where wind design is required in accordance with Figure R301.2(2) and Section R301.2.1.1, respectively.~~

AS105.4.2 Pins. *Pins* used for out-of-plane resistance shall comply with the following or shall be in accordance with an *approved* [design in accordance with Section R301.1.3](#) ~~an engineered design~~. *Pins* shall be external, internal or a combination of the two.

*[*Items 1 through 3 remain unchanged.]*

SECTION AS106 STRAWBALE WALLS—STRUCTURAL

AS106.2 Building limitations and requirements for use of strawbale structural walls. *Buildings* using *strawbale structural walls* shall be subject to the following limitations and requirements:

1. Number of stories: Not more than one, except that two stories shall be allowed with an *approved* [design in accordance with Section R301.1.3](#) ~~engineered design~~.
 2. *Building* height: Not more than 25 feet (7620 mm), except that greater heights shall be allowed with an *approved* [design in accordance with Section R301.1.3](#) ~~engineered design~~.
 3. Wall height: In accordance with Table AS105.4, AS106.13(2) or AS106.13(3) as applicable, whichever is most restrictive.
 4. Braced wall panel lengths: The greater of the values determined in accordance with Tables AS106.13(2) and AS106.13(3) for *buildings* using strawbale braced wall panels, or in accordance with Item 4 of Section AS105.2 for *buildings* with *load-bearing strawbale walls* that do not use *strawbale* braced wall panels.
-

AS106.4 Foundations. Foundations for plastered *strawbale* walls shall be in accordance with Chapter 4, Figure AS105.1(1), Figure AS105.1(2) or an *approved* [design in accordance with Section R301.1.3-engineered design](#).

AS106.8 Plaster and membranes on structural walls. *Strawbale* structural walls shall not have a membrane between straw and plaster, or shall have attachment through the *bale* wall from one plaster skin to the other in accordance with an *approved* [design in accordance with Section R301.1.3-engineered design](#).

AS106.9.2 Mesh attachment. Mesh shall be attached with staples to top plates or roof-bearing elements and to sill plates in accordance with all of the following:

1. **Staples.** Staples shall be pneumatically driven, stainless steel or electro-galvanized, 16 gage with 1¹/₂-inch (38 mm) legs, ⁷/₁₆-inch (11.1 mm) crown; or manually driven, galvanized, 15 gage with 1-inch (25 mm) legs. Other staples shall be as designed [in accordance with Section R301.1.3-by a registered design professional](#). Staples into preservative-treated wood shall be stainless steel.
 2. **Staple orientation.** Staples shall be firmly driven diagonally across mesh intersections at the required spacing.
 3. **Staple spacing.** Staples shall be spaced not more than 4 inches (102 mm) on center, except where a lesser spacing is required by Table AS106.13(1) or Section AS106.14, as applicable.
-

AS106.10 Support of plaster skins. Plaster *skins* on *strawbale* structural walls shall be continuously supported along their bottom edge. Acceptable supports include: a concrete or masonry stem wall, a concrete slab-on-grade, a wood-framed floor in accordance with Figure AS105.1(2) and an *approved* [design in accordance with Section R301.1.3-an engineered design](#) or a steel angle anchored with an *approved* [design in accordance with Section R301.1.3-engineered design](#). A weep screed as described in Section R703.7.2.1 is not an acceptable support.

AS106.11 Transfer of loads to and from plaster skins. Where plastered *strawbale* walls are used to support superimposed vertical loads, such loads shall be transferred to the plaster *skins* by continuous direct bearing in accordance with Figure AS105.1(3) or by an *approved* [design in accordance with Section R301.1.3-engineered design](#). Where plastered *strawbale* walls are used to resist in-plane lateral loads, such loads shall be transferred to the reinforcing mesh from the structural member or assembly above in accordance with Figure AS105.1(3) or AS105.1(4) and to the sill plate in accordance with Figure AS105.1(1) or AS105.1(2) and with Table AS106.13(1).

AS106.12.3 Roof-bearing assembly. Roof-bearing assemblies shall be of nominal 2-inch by 6-inch (51 mm by 152 mm) lumber with ¹⁵/₃₂-inch (12 mm) plywood or OSB panels fastened with 8d nails at 6 inches (152 mm) on center in accordance with Figure AS105.1(3) and Items 1 through 6, or be of an *approved* [design in accordance with Section R301.1.3-an engineered design](#).

*[*1 through 6 remains unchanged]*

AS106.13 Braced wall panels. Plastered *strawbale* walls used as braced wall panels for one-story *buildings* shall be in accordance with Section R602.10 and Tables AS106.13(1), AS106.13(2) and AS106.13(3). Wind design criteria shall be in accordance with Section R301.2.1. Seismic design criteria shall be in accordance with Section R301.2.2. ~~An approved engineered design in accordance with Section R301.2.1 shall be required where the building is located in a special wind region or where wind design is required in accordance with Figure R301.2(2) and Section R301.2.1.1, respectively.~~

AS106.13.3 Sill plate fasteners. Sill plates shall be fastened with not less than ⁵/₈-inch-diameter (15.9 mm) steel anchor bolts with 3-inch by 3-inch by ³/₁₆-inch (76.2 mm by 76.2 mm by 4.8 mm) steel washers, with not less than 7-inch (177.8 mm) embedment in a concrete or masonry foundation, or shall be an *approved* equivalent, with the spacing shown in Table AS106.13(1). Anchor bolts or other fasteners into framed floors shall be of an *approved* [design in accordance with Section R301.1.3-engineered design](#).

AS106.15 Post-and-beam with strawbale infill. Post-and-beam with *strawbale* infill systems shall be in accordance with Figure AS105.1(4) and Items 1 through 7, or be of an *approved* [design in accordance with Section R301.1.3-engineered design](#).

*[*1 through 7 remains unchanged.]*

APPENDIX AT SOLAR-READY PROVISIONS— DETACHED ONE- AND TWO-FAMILY DWELLINGS AND TOWNHOUSES

Appendix AT of the 2021 International Residential Code is not adopted by the State of Oregon, Building Codes Division, as part of this code. The subject matter in this appendix is preempted by the provisions of the state building code and may not be adopted by a municipality.

[The rest of Appendix AT is deleted in its entirety.]

APPENDIX AU COB CONSTRUCTION (MONOLITHIC ADOBE)

New model code:

Appendix AU details compliance requirements for COB construction, which are distinctly different than the requirements for light straw-clay and strawbale construction.

SECTION AU104 FINISHES

AU104.1.2 Exterior wall finishes. Where installed, exterior wall *finishes* shall be *plasters* in accordance with Section AU104.4, nonplaster exterior wall coverings in accordance with Section R703, or other *finish* systems in accordance with the following:

1. Specifications and details of the *finish* system's means of attachment to the wall or its independent support and means of draining or evaporating water that penetrates the exterior finish shall be provided.
2. The vapor permeance of the combination of *finish* materials shall be 5 perms or greater to allow the transpiration of water vapor from the wall.
3. *Finish* systems with weights greater than 10 pounds per square foot (48.9 kg/m) and less than or equal to 20 pounds per square foot (97.8 kg/m) of wall area shall require that the minimum total length of *braced wall panels* in Table AU106.11(3) be multiplied by a factor of 1.2.
4. *Finish* systems with weights greater than 20 pounds per square foot (97.8 kg/m) of wall area shall require an [design in accordance with Section R301.1.3](#) ~~engineered design~~.

AU104.4 Plaster. *Plaster* applied to *cob* walls shall be any type described in this section. *Plaster* thickness shall not exceed 3 inches (76 mm) on each face except where an *approved* [design in accordance with Section R301.1.3](#) ~~engineered design~~ is provided.

SECTION AU105 COB WALLS—GENERAL

AU105.2 Building limitations and requirements for cob wall construction. *Cob* walls shall be subject to the following limitations and requirements:

1. Number of stories: not more than one.
2. Building height: not more than 20 feet (6096 mm).
3. *Seismic design categories*: limited to use in *Seismic Design Categories* A, B and C, except where an *approved* [design in accordance with Section R301.1.3](#) ~~engineered design~~ is provided.
4. Wall height: in accordance with Table AU105.3, and with Table AU106.11(1) for *braced wall panels*.
5. Wall thickness, excluding *finish*, shall be not less than 10 inches (254 mm), not greater than 24 inches (610 mm) at the top two-thirds, not limited at the bottom third and, for structural walls, shall comply with Section AU106.2, Item 2. Wall taper is permitted in accordance with Section AU106.5, Item 1.
6. Interior *cob* walls shall require an *approved* engineered design that accounts for the seismic load of the interior *cob* walls, except in Seismic Design Category A for walls with a height to thickness ratio less than or equal to 6.

AU105.3.1 Determination of out-of-plane loading. Out-of-plane loading for the use of Table AU105.3 shall be in accordance with the [basic](#) design wind speed and seismic design category requirements of Sections R301.2.1 and R301.2.2, respectively. ~~An approved engineered design shall be required where the building is located in a special wind region or where wind design is required in accordance with Figure R301.2.1.1.~~

**TABLE AU105.3
OUT-OF-PLANE RESISTANCE METHODS AND UNRESTRAINED WALL HEIGHT LIMITS**

WALL TYPE ^{a, g, h} AND METHOD OF OUT-OF-PLANE LOAD RESISTANCE	FOR BASIC DESIGN WIND SPEEDS (mph)	FOR SEISMIC DESIGN CATEGORIES	UNRESTRAINED COB WALL HEIGHT $H^{b, c, h}$		TOP ANCHOR ^e SPACING (inches)	TENSION TIE ^f SPACING (inches)
			Absolute Limit (feet)	Limit Based on Wall Thickness T^d (feet)		

*[*The rest of the table remains unchanged.]*

For SI: 1 inch = 25.4 mm, 1 foot = 304.8 mm, 1 mile per hour = 0.447 m/s.

N/A = Not Applicable

- a. See Table AU106.11(1) for reinforcing and anchorage specifications for wall Types A, B, C, D and E.
- b. H = height of the cob portion of the wall only. See Figure AU101.4. The maximum H is the absolute limit or the limit based on wall thickness, whichever is more restrictive.
- c. Bond beams or other horizontal restraints are capable of separating a wall into more than one unrestrained wall height with an approved [design in accordance with Section R301.1.3-engineered design](#).
- d. T = Cob wall thickness (in feet) at its minimum, without plaster.
- e. $\frac{5}{8}$ -inch threaded rod anchors at prescribed spacing with 12-inch embedment in cob, full embedment in concrete bond beams or full penetration in wood bond beam with a nut and washer.
- f. Attach rafters to bond beam with 4-inch by 3-inch by 3-inch by 18 gage tension tie angles at prescribed spacing. See Figure AU106.9.5. Where rafters are attached to tension ties, roof sheathing shall be edge nailed.
- g. All walls shall be tested for compressive strength in accordance with Section AU106.6.
- h. For curved walls with an arc length to radius ratio of 1.5:1 or greater, the H/T factor shall be increased by 1, and the absolute height limit by 1 foot.
- i. Wall type requires a modulus of rupture test in accordance with Section AU106.7.
- j. See wall Type A in Table AU106.11(1) for top anchor requirements.

SECTION AU106 COB WALLS—STRUCTURAL

AU106.1 General. Cob structural walls shall be in accordance with the prescriptive provisions of this section. Designs or portions of designs not complying with this section shall require an [approved design in accordance with Section R301.1.3-engineered design](#).

AU106.8.2 Support of concentrated loads. Concentrated roof and ceiling loads shall be distributed by structural elements capable of distributing the loads to the *cob load-bearing wall* and within its allowable bearing capacity as determined in accordance with Section AU106.8. Concentrated loads over lintels or over bond beams spanning openings shall require an [approved design in accordance with Section R301.1.3-engineered design](#).

AU106.9.3 Other bond beams. Bond beams of other materials, including earthen materials, require an [approved design in accordance with Section R301.1.3-engineered design](#).

AU106.11 Cob braced wall panels. Cob braced wall panels shall be in accordance with Section R602.10 and Tables AU106.11(1), AU106.11(2), AU106.11(3), AU106.11(4) and AU106.11(5). Wind design criteria shall be in accordance with Section R301.2.1. Seismic design criteria shall be in accordance with Section R301.2.2. ~~An approved engineered design shall be required in accordance with Section R301.2.1 where the building is located in a special wind region or where wind design is required in accordance with Figure R301.2.1.1.~~

AU106.13 Post-and-beam with cob infill. Post-and-beam with cob infill wall systems shall be in accordance with an [approved design in accordance with Section R301.1.3-engineered design](#).

AU106.14 Buttresses. Cob buttresses that are intended to provide out-of-plane wall bracing or additional capacity for braced wall panels shall be in accordance with an [approved design in accordance with Section R301.1.3-engineered design](#).

APPENDIX AV BOARD OF APPEALS

Appendix AV of the 2021 International Residential Code is not adopted by the State of Oregon, Building Codes Division, as part of this code. The subject matter in this appendix is preempted by the provisions of the state building code and may not be adopted by a municipality.

[The rest of Appendix AV is deleted in its entirety.]

APPENDIX AW 3D-PRINTED BUILDING CONSTRUCTION

New model code

Appendix AW adds requirements for 3D printed homes, still relying heavily on R104.11 for approval. UL 3401 sets forth the primary compliance path and is required by the appendix.

View the appendix here: <https://codes.iccsafe.org/content/IRC2021P2/appendix-aw-3d-printed-building-construction>.

APPENDIX AX ZERO ENERGY RESIDENTIAL BUILDING PROVISIONS

Appendix AX of the 2021 International Residential Code is not adopted by the State of Oregon, Building Codes Division, as part of this code. The subject matter in this appendix is preempted by the provisions of the state building code and may not be adopted by a municipality.

[The rest of Appendix AX is deleted in its entirety.]