

OPERATION & MAINTENANCE MANUAL

Filterra

Manual prepared: March 2023

DFI No. D01535



Figure 1: DFI No. D01535, looking West

1. Identification

Drainage Facility ID (DFI): D01535
Facility Type: Filterra
Construction Drawings: (V-File Numbers)
Location: District: 03
Highway No.: 161
Mile Post: 0.21, Left

2. Manual Purpose

The purpose of this manual is to outline inspection needs and summarize maintenance actions for planted water quality catch basins.

3. Facility Location

The location map below details the facility location. The highway, mile posts, side streets, access location, and stormwater flow directions are noted on the map.

Facility location type: Curb and Gutter (travel lane)

Flow direction: West

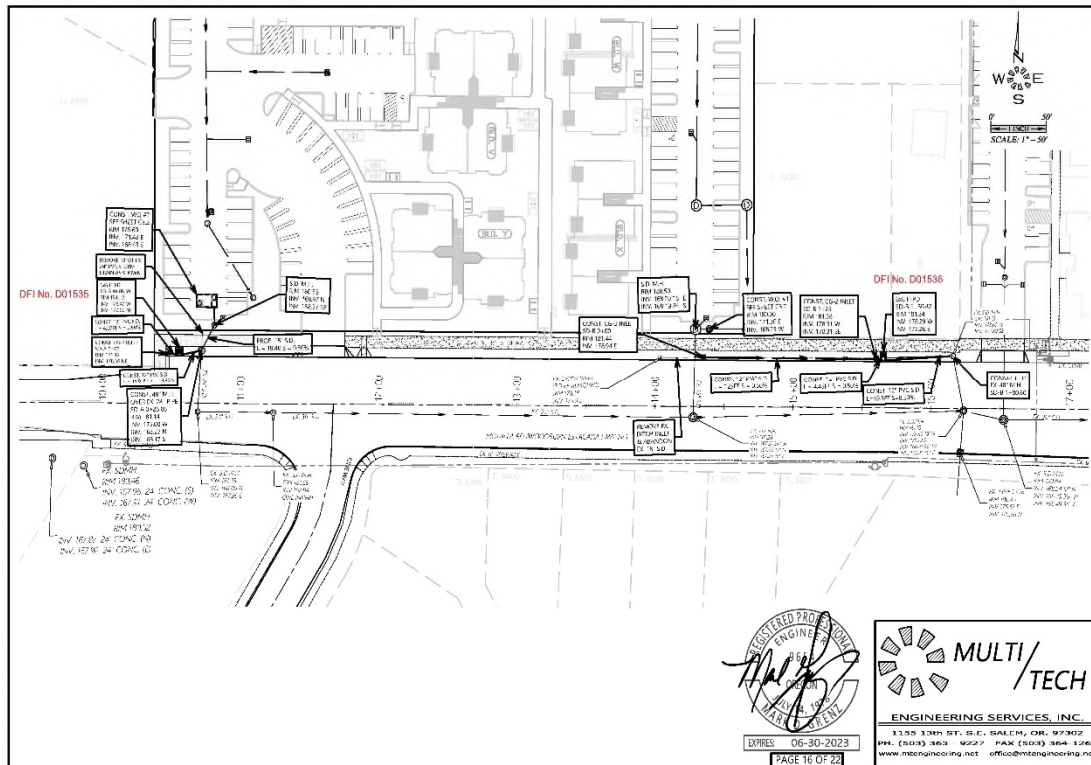

Figure 2: Facility Location Map

4. Facility Summary

The length and width of the WQ Catch Basin is based on the dimensions of the inside of the treatment cell.

The length and width of the WQ Catch Basin is:

Length (Feet)	Width (Feet)	Designation Number ¹
6	4	FTPD0604

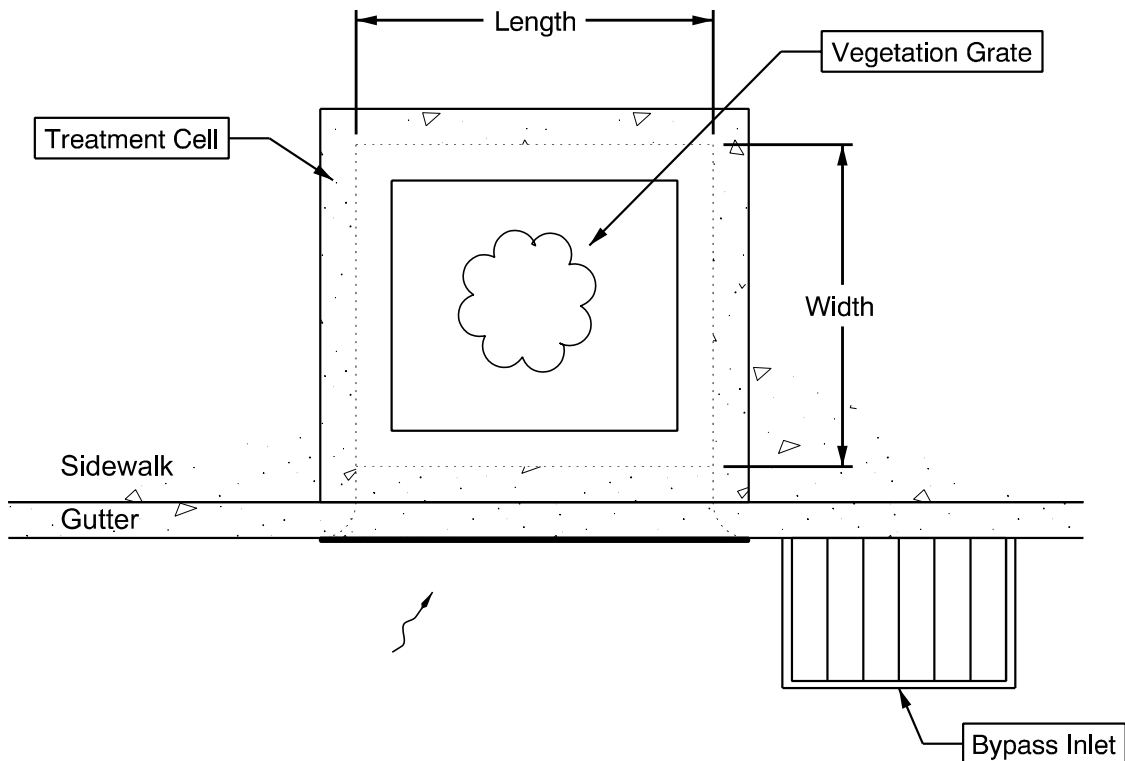

Site Specific Information: This facility is located within the planting strip along the northern side of US 211. See Appendix B for additional information.

¹ The Filterra and MWS designation number is associated with the dimensions of this type of proprietary structure. See appendix C of the Standard Operation Manual for Water Quality Catch Basins to view the Configuration Details for additional information.

5. Facility Access

Maintenance access to the facility: Curb and gutter (travel lane)

Lane Closure Needed

Water quality catch basins do not typically have access roads/access pads, nor are they gated, as they are located in urban areas alongside sidewalks and curbs. Use caution when accessing these facilities as there may be pedestrians or cyclists in the vicinity.

6. Operational Components / Maintenance Items

Classification and Standard Operational (Op) Plan:

This facility is classified as a:

<input checked="" type="checkbox"/> Filterra (Op Plan A)	<input type="checkbox"/> WQ Planter (Op Plan B)	<input type="checkbox"/> MWS (Op Plan C)
A Filterra is a single chamber treatment cell that utilizes filter media, a plant, and a perforated underdrain.	A WQ Planter is a single chamber treatment cell that utilizes plants, filter media, and a perforated underdrain. The auxiliary outlet is located inside of the treatment cell.	A <u>Modular Wetland System</u> is a three chamber treatment cell that utilizes plants, filter media, filter media cartridges, and a perforated underdrain network.
A standard operational plan illustrates the general facility footprint configuration and explains the purpose of each facility component. Operational plans (A and B) are provided in the Standard Operation Manual.		

See Appendix A for the site-specific operational plan.

Operational Components

The facility components table (**Table 1**) highlights the applicable components for this facility. The component is in use when the box contains an “x” (e.g.).

The Standard Operation Manual for Water Quality Catch Basins (implemented April 2018) outlines facility operation, typical footprint configuration, and component definitions and details. A link to the manual is attached to the feature marker in TransGIS. <https://gis.odot.state.or.us/TransGIS/>

Maintenance Items

Operational components marked in **Table 1** should be inspected and maintained according to Section 7. Each facility component is defined and detailed in the Standard Operation Manual using the associated ID number indicated below.

Table 1: Catch Basin Components		ID #
Facility Inlet		
Inlet Grate	<input type="checkbox"/>	C1
Curb Inlet	<input type="checkbox"/>	C2
Sidewalk Chute	<input type="checkbox"/>	C3
Bypass Inlet	<input checked="" type="checkbox"/>	C4
Treatment		
Filter Media	<input checked="" type="checkbox"/>	C5
Filter Media Cartridge	<input type="checkbox"/>	C6
Outfall Type		
Waterbody (Creek/Lake/Ocean)	<input type="checkbox"/> C	C7
	<input type="checkbox"/> L	
	<input type="checkbox"/> O	
Ditch	<input type="checkbox"/>	C8
Storm Drain System	<input checked="" type="checkbox"/>	C9
Plantings		
Plantings (Tree or Shrub)	<input checked="" type="checkbox"/>	C10

7. Maintenance

Maintenance Frequency/Maintain Records

- Inspect per manufacturer requirements, preferably prior to the rainy season.
- Clean and maintain as necessary. Refer to Activity 125 in the Maintenance Guide for conditions when maintenance is needed.
- Keep a record of inspections, maintenance, and repairs.

Maintenance Guide/Maintenance Actions

Proprietary Water Quality Catch Basins have an operation and maintenance manual provided by the manufacturer. See Appendix C of the Standard Operational Manual for Water Quality Catch Basins. These manuals provided guidelines on maintenance procedures for the facilities. A link to the manual is attached to the feature marker in TransGIS. <https://gis.odot.state.or.us/TransGIS/>

The ODOT Maintenance Guide lists the standard maintenance actions for water quality facilities under Activity 125.

Standard maintenance tables describe the maintenance component, the potential defect or problem, the condition when maintenance is needed, and the recommended maintenance to correct the problem. Use the following tables to maintain ODOT Water Quality Catch Basins:

- Table 1 (General Maintenance): Contains general maintenance and inspection guidelines that are applicable to all ODOT water quality facilities.

The *Maintenance Guide* can be viewed here:

<http://transnet.odot.state.or.us/hwy/MaintOPs/Pages/Maintenance%20Guide.aspx>

8. Waste Disposal

Material removed from the facility is defined as waste by the Department of Environmental Quality (DEQ). Refer to the road waste section of the ODOT Maintenance Yard Environmental Management System (EMS) Policy and Procedures Manual for disposal options:

http://www.oregon.gov/ODOT/Maintenance/Documents/ems_manual.pdf

Contact any of the following for more detailed information about management of waste materials found on site:

ODOT Materials Management Coordinator	(503) 731-8493
ODOT Statewide Hazmat Coordinator	(503) 667-7442
ODOT Region 1 Hazmat Coordinator	(503) 731-8290
ODOT Region 2 Hazmat Coordinator	(503) 986-2647
ODOT Region 3 Hazmat Coordinator	(541) 957-3594
ODOT Region 4 Hazmat Coordinator	(541) 388-6186
ODOT Region 5 Hazmat Coordinator	(541) 963-1590
ODEQ Northwest Region Office	(503) 229-5263

A Appendix A – Site Specific Operational Plan

Contents:

Operational Plan: DFI D01535

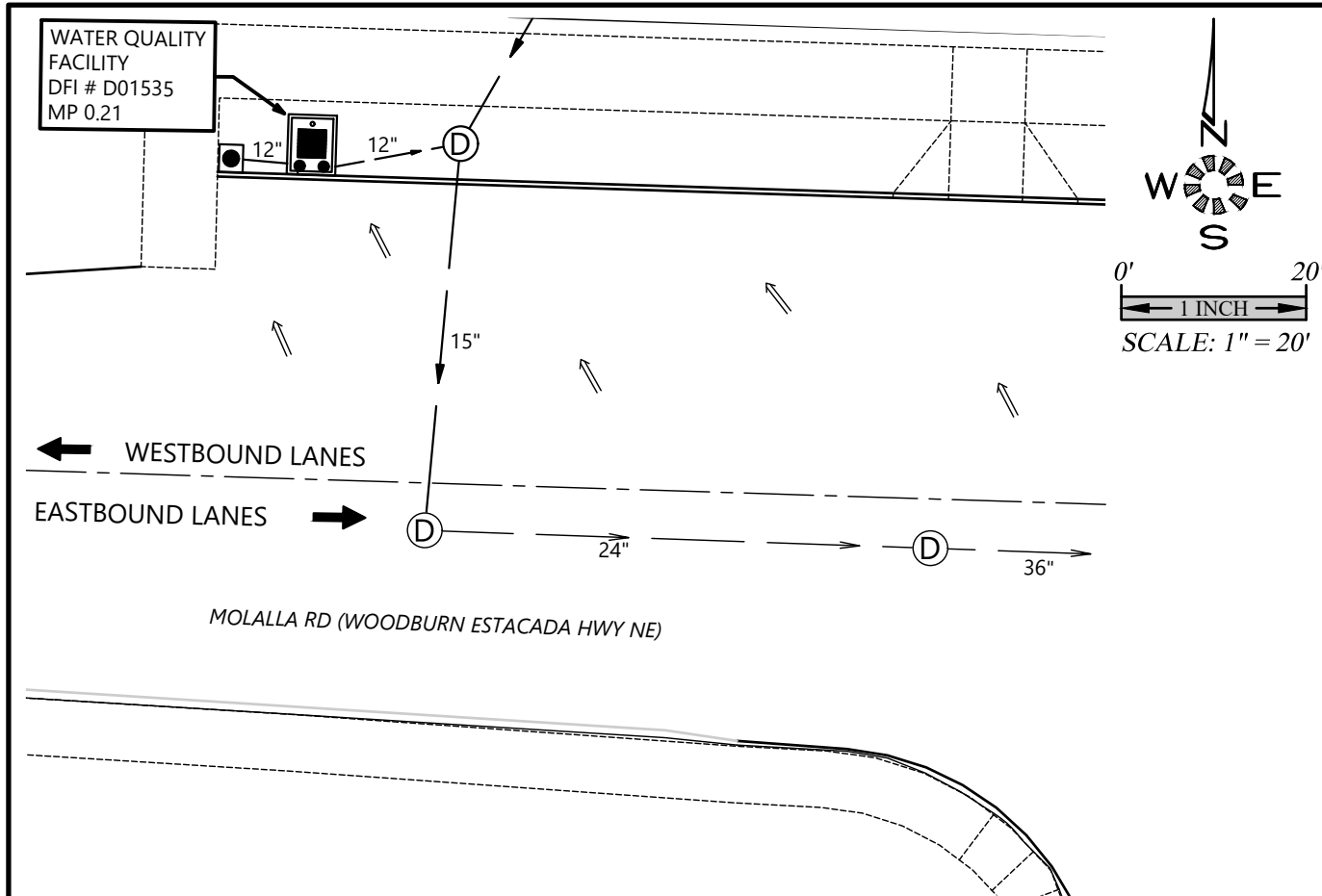

PIPE DRAINAGE SYSTEM DFI D01535 SCHEMATIC

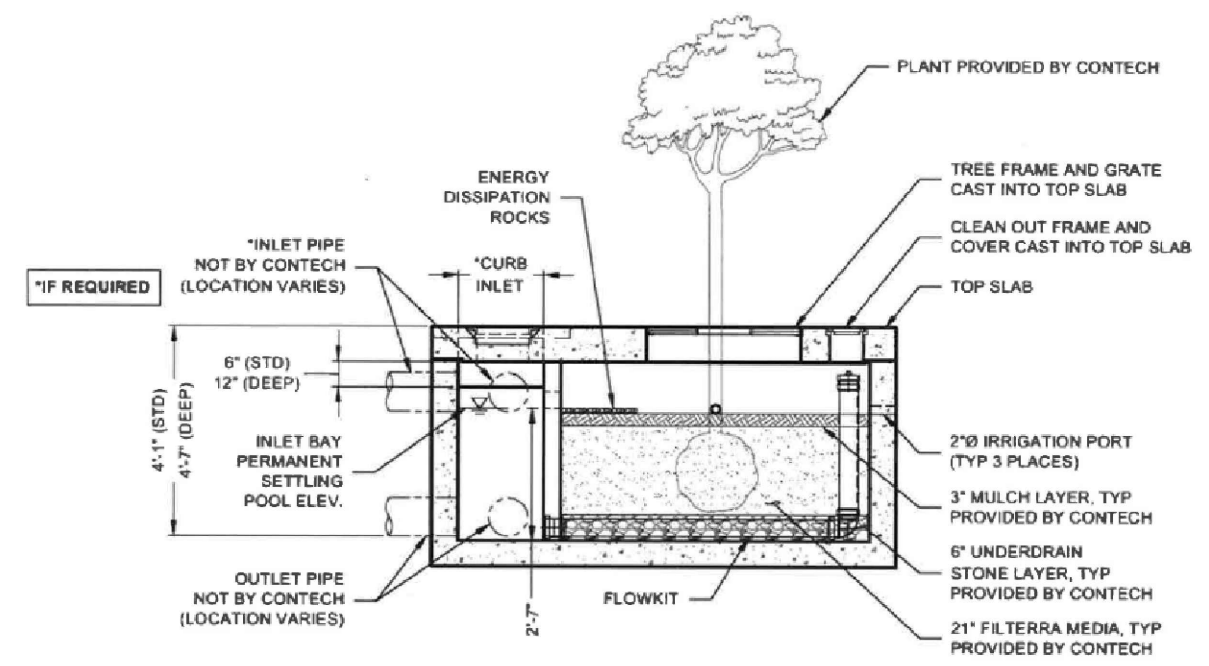

WATER QUALITY FACILITY D01535
6x6 FTPD UNIT DETAIL

SYMBOL/LINEWORK LEGEND:

- | | | | |
|--|----------------------------|--|-----------------------|
| | WATER QUALITY FACILITY | | STORM PIPE |
| | INLET | | ROADWAY CENTERLINE |
| | DRAINAGE MANHOLE | | CURB/EDGE OF PAVEMENT |
| | PAVEMENT/FACILITY FLOWPATH | | SIDEWALK |

MULTI/TECH
ENGINEERING SERVICES, INC.
1155 13th ST. S.E. SALEM, OR. 97302
PH. (503) 363 - 9227 FAX (503) 364-1260
www.mtengineering.net office@mtengineering.net

J:\74xx\7402-WoodburnPlace\WestAp\DWG v2\7402-O&M_EXPORT.dwg, 1 OF 2, 5/2/2023 3:38:30 PM, RHaselton, RHaselton

B Appendix B – Project Contract Plans

Contents:

Site Specific Subset of Project Contract Plan

SHEET INDEX

- SHEET 1 COVER SHEET
- SHEET 2 SITE PLAN
- SHEET 3 OFFSITE WATER LINE IMPROVEMENTS 1
- SHEET 4 OFFSITE WATER LINE IMPROVEMENTS 2
- SHEET 5 ONSITE DETENTION PLAN
- SHEET 6 O.D.O.T LIGHTING PLAN
- SHEET 7 STREET IMPROVEMENT PLAN
- SHEET 8 SIDEWALK PLAN
- SHEET 8 STREET SECTIONS SHEET 1
- SHEET 9 STREET SECTIONS SHEET 2
- SHEET 10 STREET SECTIONS SHEET 3
- SHEET 11 STREET SECTIONS SHEET 4
- SHEET 12 STREET SAW CUT PLAN
- SHEET 13 PUBLIC STRIPING PLAN
- SHEET 14 PUBLIC STRIPING PLAN DETAILS
- SHEET 15 PUBLIC STORM DRAIN PLAN 1
- SHEET 16 PUBLIC STORM DRAIN PLAN 2
- SHEET 17 DETAILS SHEET 1
- SHEET 18 DETAILS SHEET 2
- SHEET 19 DETAILS SHEET 3
- SHEET 20 DETAILS SHEET 4

WOODBURN PLACE WEST

SEC. 08, T. 5 S., R. 1 W., W.M.
CITY OF WOODBURN
MARION COUNTY, OREGON

Owner / Developer:

WOODBURN PLACE
APARTMENTS, LLC.
27375 SW PARKWAY AVE
WILSONVILLE, OR, 97070
PHONE: (503) 655-7933



VICINITY MAP
N.T.S.

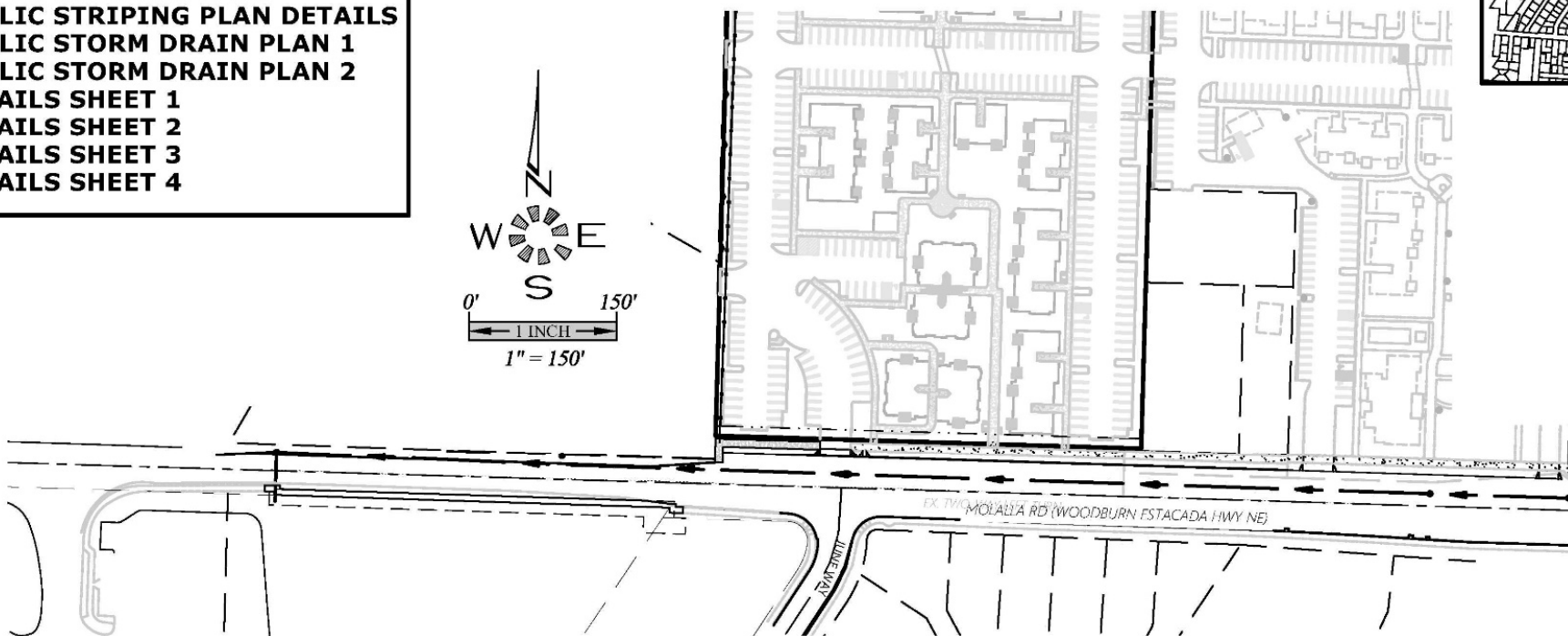
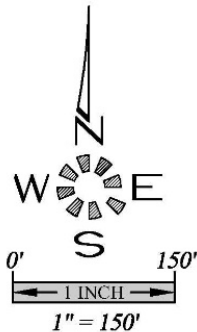

ABBREVIATIONS	
A.C.	ASPHALTIC CONCRETE
ACWP	ALUMINIZED CHP
ASST	ASSEMBLY
B.O.	BLOW OFF
B.F.V.	BUTTERFLY VALVE
C & G	CURB & GUTTER
CATV	CABLE TELEVISION
C.B.	CATCH BASIN
C.B.C.D.	CATCH BASIN CLEANOUT
C.B.I.	CATCH BASIN INLET
C.L.	CENTERLINE
CMF	CONCRETE METAL PIPE
C.O.	CLEANOUT
CONC.	CONCRETE
CONCT.	CONSTRUCT
D.I.	DUCTILE IRON
DIA.	DIAMETER
DWG.	DRAWING
EASMT.	EASEMENT
E.G.	EXIST. GRADE / GROUND
EOP, E.F.	EDGE OF PAVEMENT
ELEC.	ELECTRIC
ELEV. or E.	ELEVATION
EX. or EXIST.	EXISTING
FT.	FEET
F.F.	FRESH FLOOR
F.G.	FINISH GRADE
F.H.	FIRE HYDRANT
F.M.	FENCE MAIN
GUT. or GTR.	GUTTER
G.V.	GATE VALVE
IMP.	IMPROVEMENT
INST.	INSET
INV. or I.	INVERT
L.V.	LENGTH LINE
L.P.	LIGHT POLE
M.	METER, MAIN
M.H.	MANHOLE
MTL.	METAL
O.H.	OVERHEAD
P.C.	POINT OF CURVE
P.C.C.	POINT OF CONTINGING CURVE
PED.	PEDESTAL
P.R.C.	POINT OF REVERSE CURVE
PROP.	PROPOSED
P.T.	POINT OF TANGENCY
PUB.	PUBLIC
PUB.	PUBLIC UTILITY EASMT.
PVC.	POLYVINYL CHLORIDE
P.V.T.	PROMOTE
P.P.	POWER POLE
P.L.	PROPERTY LINE
R.	RADIUS
R.O.	ROOF
R.D.	RIGHT-OF-WAY
S.M.S. or S.S.	SANITARY SEWER
S.	SLOPE
STA.	STATION
STD.	STANDARD
STL.	STEEL
STM.DRN. or S.D.	STORM DRAIN
SVC.	SERVICE
S.W.	SUBURBAN
T.C.	TOP OF CURB
TEL.	TELEPHONE
TYP.	TYPICAL
U.G.	UNDERGROUND
W.L.T.	WALK
W.M.	WATER MAIN

SYMBOLS			
EXIST. PROP.	EXIST. PROP.		
○	BLOW OFF ASST.	○	MANHOLE SAN. SEWER
■	CATCH BASIN	○	MANHOLE STORM DRAIN
■	CATCH BASIN CLEANOUT	○	2' DIA. C.O. / M.H.
■	CATCH BASIN INLET	○	MANHOLE TELEPHONE
▲	CATV PED. / BOX	○	MANHOLE WATER
○	CLEANOUT	○	REDUCER / INCREASER
○	ELEC. PED. / BOX	○	TEL. PED. / BOX
○	FIRE HYDRANT	○	TRAFFIC PED. / BOX
○	GAS LOCATION MARKER	○	UTILITY / POWER POLE
○	GAS VALVE	○	WATER METER
○	MAIL BOX	○	WATER VALVE
---	CABLE TELEVISION	---	SANITARY SEWER EXIST.
---	CENTERLINE	---	SANITARY SEWER PROP.
---	DOTCH C.L.	---	STORM DRAIN EXIST.
---	ELECTRICAL LINE	---	STORM DRAIN PROP.
---	GAS MAIN	---	WATER MAIN EXIST.
---	TELEPHONE LINE	---	WATER MAIN PROP.

J:\744x7402-WoodburnPlaceWestAptDwg v20\7402b.dwg, 01-COV, 1/25/2023 8:26:09 AM, RHaseleton, RHaseleton

THE ENGINEER OF RECORD TEAM TO PROVIDE CONSTRUCTION INSPECTIONS AND COORDINATE CONSTRUCTION SCHEDULES WITH THE CITY'S ENGINEERING DIVISION SUCH THAT THE CITY'S INSPECTOR CAN BE PRESENT FOR OBSERVATIONS THAT REQUIRES THE CITY'S PRESENCE. DURING CONSTRUCTION, THE CONTRACTOR SHALL CONTACT THE ENGINEER OF RECORD FOR QUESTIONS RELATED AND POSSIBLE MODIFICATIONS TO THE APPROVED PLANS AND PROJECT LIMITS. THE ENGINEER OF RECORD SHALL SUBMIT PLAN MODIFICATIONS DURING CONSTRUCTION TO THE CITY AND ODOT FOR APPROVAL PRIOR TO START WORK.

ALL PUBLIC SEWER AND WATER MAIN PIPES REQUIRE TRACER WIRES, INCLUDING DUCTILE IRON PIPES AND SERVICES TO/FROM MAIN TO PROPERTY LINES.

ENGINEER OF RECORD IS RESPONSIBLE FOR DIRECTLY COORDINATING CONSTRUCTION SCHEDULES WITH THE CITY'S ENGINEERING DIVISION SUCH THAT THE CITY INSPECTOR CAN BE PRESENT FOR OBSERVATIONS THAT REQUIRES THE CITY'S PRESENCE.



EXPIRES: 06-30-2023
PAGE 1 OF 20

MULTI/TECH

ENGINEERING SERVICES, INC.

1155 13th ST. S.E. SALEM, OR. 97302
PH. (503) 363 - 9227 FAX (503) 364-1260
www.mtengineering.net office@mtengineering.net

J:\4x4\7402-WoodburnPlace\West\Apt\DWg-v20\7402b-dwg-16-SD.1-2/1/2023 8:51:48 AM, RHasselton, RHasselton

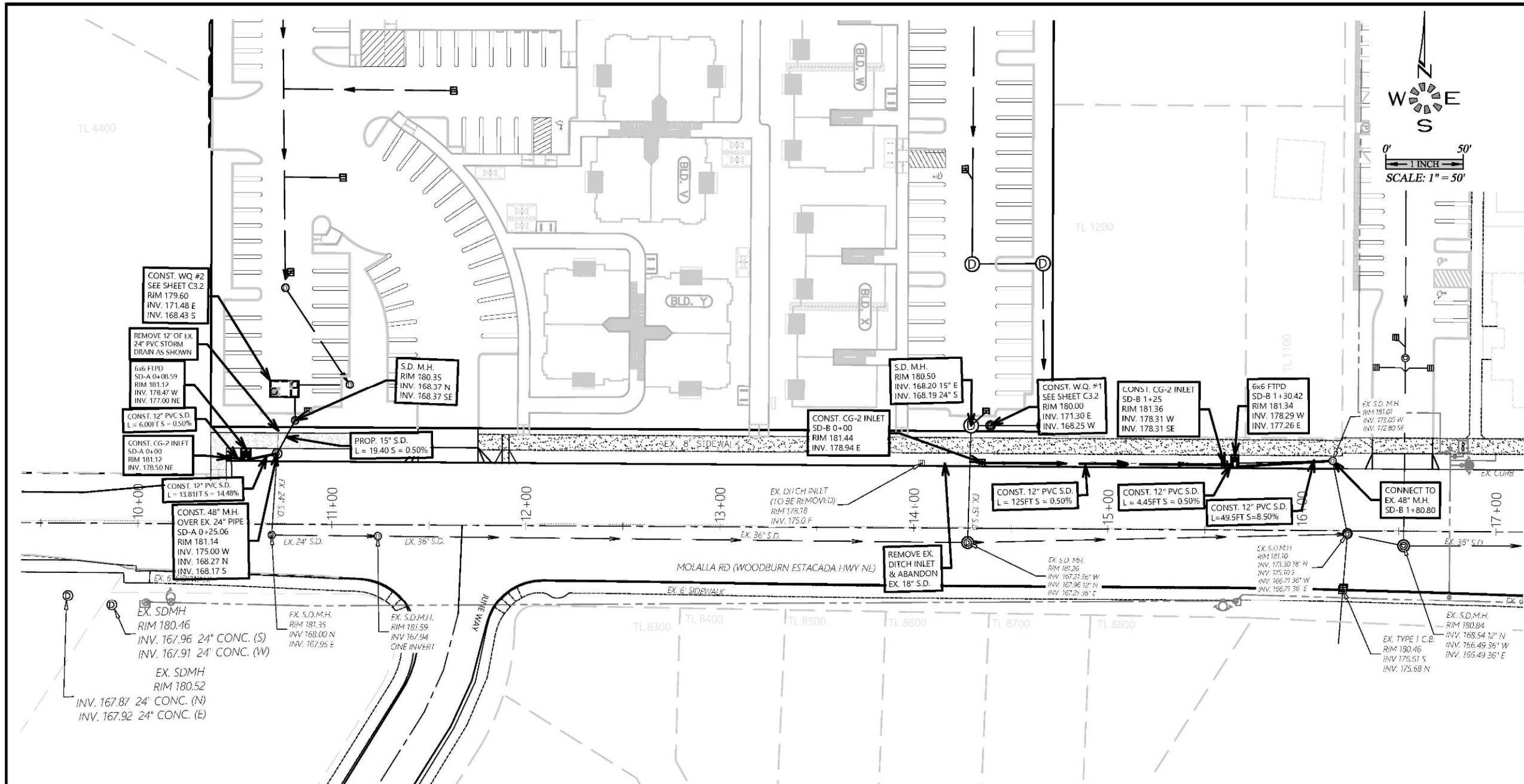

MULTI/TECH

ENGINEERING SERVICES, INC.

1155 13th ST. S.E. SALEM, OR. 97302
 PH. (503) 363 - 9227 FAX (503) 364-1260
 www.mtengineering.net office@mtengineering.net

J:\14x17402-WoodburnPlaceWest\1Dwg v20\17402b.dwg, 17-SD.2, 3/17/2023 2:28:26 PM, RHaselton, RHaselton

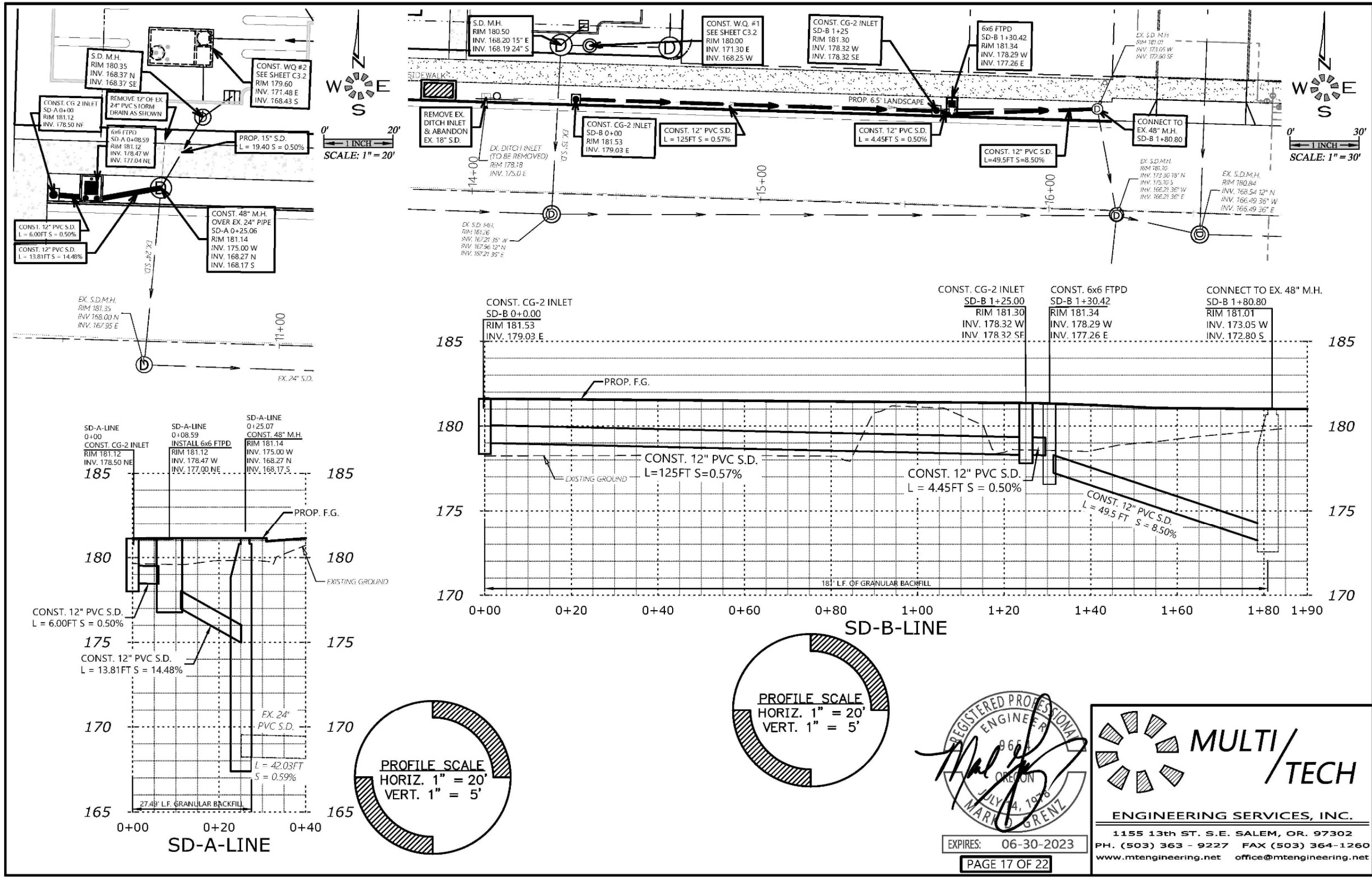

MULTI/TECH
 ENGINEERING SERVICES, INC.
 1155 13th ST. S.E. SALEM, OR. 97302
 PH. (503) 363-9227 FAX (503) 364-1260
 www.mtengineering.net office@mtengineering.net

I:\STORMWATER\COM\PS4 FILTERRA40 STANDARD DRAWINGS\FTPD - FILTERRA PEAK DIVERSION\FTPD LAYOUT DETAILS\DWG\FTPD - WIA.DWG 7/1/2020 11:56:4M

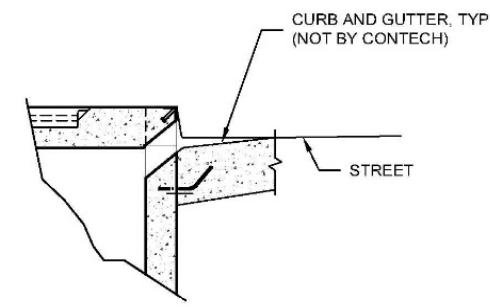
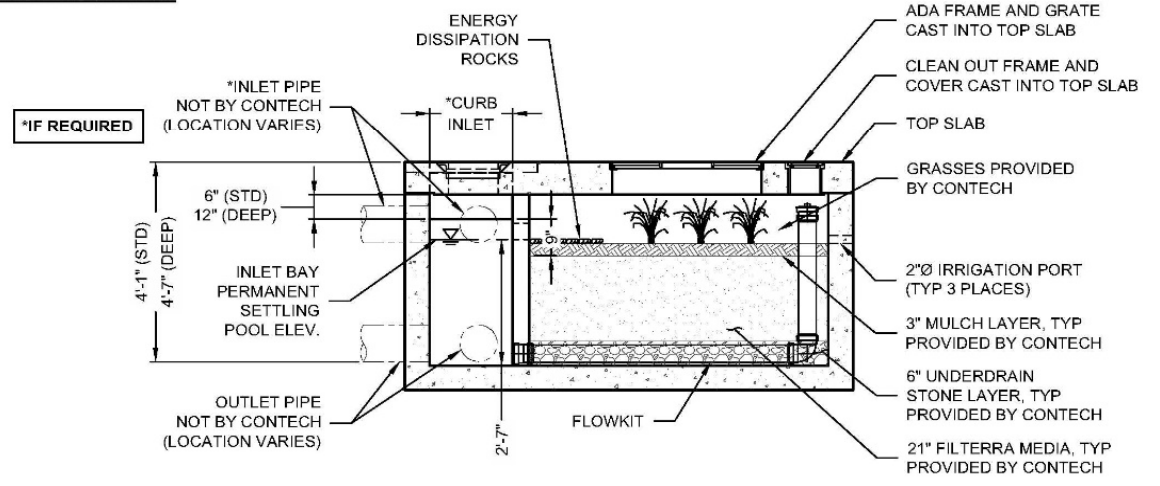
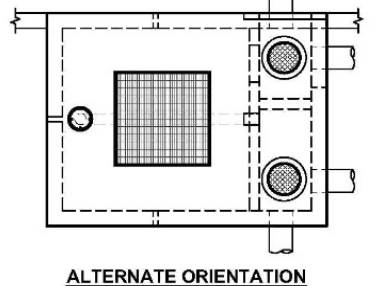
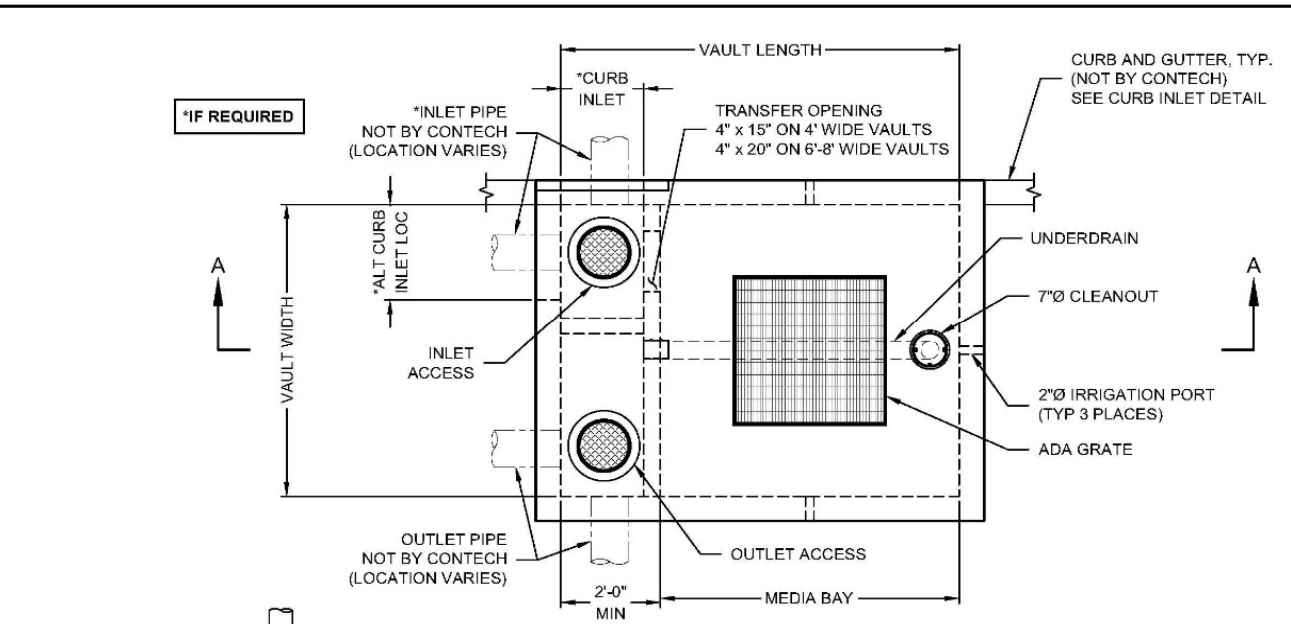

FTPD STANDARD HEIGHT CONFIGURATION						
DESIGNATION (OPTIONS: -P, -T, -PT)	AVAILABILITY	MEDIA BAY SIZE	VAULT SIZE (W x L)	WEIR LENGTH/ MAX CURB OPENING	INLET/ OUTLET ACCESS DIA	TREE GRATE QTY & SIZE
FTPD0404	N/A CA	4 x 4	4 x 6	1'-8"	12"/12"	(1) 3' x 3'
FTPD04045	CA ONLY	4 x 4.5	4 x 6.5	1'-8"	12"/12"	(1) 3' x 3'
FTPD0406	N/A MID-ATL	4 x 6	4 x 8	1'-8"	12"/12"	(1) 3' x 3'
FTPD045058	MID-ATL ONLY	4.5 x 5.83	4.5 x 7.83	1'-8"	12"/12"	(1) 3' x 3'
FTPD0604	ALL	6 x 4	6 x 6	1'-8"	12"/12"	(1) 3' x 3'
FTPD0606	ALL	6 x 6	6 x 8	1'-8"	12"/12"	(1) 3' x 3'
FTPD0608	ALL	6 x 8	6 x 10	1'-8"	12"/12"	(1) 4' x 4'
FTPD0610	ALL	6 x 10	6 x 12	1'-8"	12"/12"	(1) 4' x 4'
FTPD0710	ALL	7 x 10	7 x 13	2'-6"	24"/24"	(1) 4' x 4'
FTPD08105	ALL	8 x 10.5	8 x 14	3'-0"	24"/24"	(1) 4' x 4'
FTPD08125	ALL	8 x 12.5	8 x 16	3'-0"	24"/24"	(2) 4' x 4'

N/A = NOT AVAILABLE

FTPD-D DEEP OPTION CONFIGURATION						
DESIGNATION (OPTIONS: -P, -T, -PT)	AVAILABILITY	MEDIA BAY SIZE	VAULT SIZE (W x L)	WEIR LENGTH/ MAX CURB OPENING	INLET/ OUTLET ACCESS DIA	TREE GRATE QTY & SIZE
FTPD0404-D	N/A CA	4 x 4	4 x 6	1'-8"	12"/12"	(1) 3' x 3'
FTPD04045-D	CA ONLY	4 x 4.5	4 x 6.5	1'-8"	12"/12"	(1) 3' x 3'
FTPD0406-D	N/A MID-ATL	4 x 6	4 x 8	1'-8"	12"/12"	(1) 3' x 3'
FTPD045058-D	MID-ATL ONLY	4.5 x 5.83	4.5 x 7.83	1'-8"	12"/12"	(1) 3' x 3'
FTPD0604-D	ALL	6 x 4	6 x 6	1'-8"	12"/12"	(1) 3' x 3'
FTPD0606-D	ALL	6 x 6	6 x 8	1'-8"	12"/12"	(1) 3' x 3'
FTPD0608-D	ALL	6 x 8	6 x 10	1'-8"	12"/12"	(1) 4' x 4'
FTPD0610-D	ALL	6 x 10	6 x 12	1'-8"	12"/12"	(1) 4' x 4'
FTPD0710-D	ALL	7 x 10	7 x 13	2'-6"	24"/24"	(1) 4' x 4'
FTPD08105-D	ALL	8 x 10.5	8 x 14	3'-0"	24"/24"	(1) 4' x 4'
FTPD08125-D	ALL	8 x 12.5	8 x 16	3'-0"	24"/24"	(2) 4' x 4'

N/A = NOT AVAILABLE

*MAX BYPASS FLOW IS INTERNAL WEIR FLOW. SITE SPECIFIC ANALYSIS IS REQUIRED TO DETERMINE CURB INLET FLOW CAPACITY

INTERNAL PIPE CONFIGURATION MAY VARY DEPENDING UPON OUTLET LOCATION.



CONTECH
ENGINEERED SOLUTIONS LLC
www.ContechES.com
9025 Centre Pointe Dr., Suite 400, West Chester, OH 45069
800-338-1122 513-645-7000 513-645-7993 FAX

FILTERRA PEAK DIVERSION (FTPD) CONFIGURATION DETAIL

C Appendix C – Manufacturer provided O & M

Contents:

Site Specific Subset of Project Contract Plan

Filterra Owner's Manual



filterra[®]
Bioretention Systems

C NTECH[®]
ENGINEERED SOLUTIONS

This Owner's Manual applies to all precast Filterra Configurations, including Filterra Bioscape Vault.

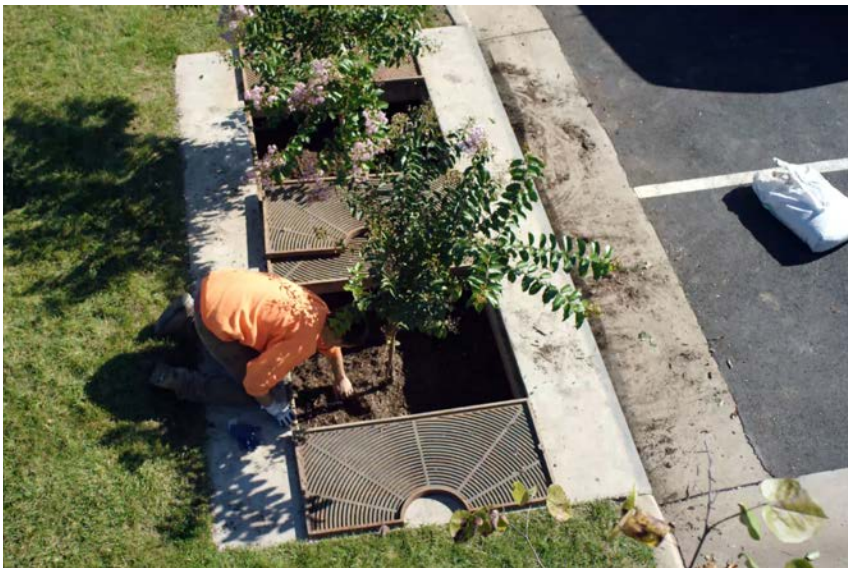



Table of Contents

Introduction	4
Activation Overview	4
Filtererra Plant Selection Overview	6
Warranty Overview	6
Routine Maintenance Guidelines.....	6
Maintenance Visit Procedure.....	9
Appendix 1 – Activation Checklist	12
Appendix 2 – Planting Requirements for Filtererra Systems.....	13
Appendix 3 – Filtererra Tree Grate Opening Expansion Procedure	15



Introduction

Thank you for your purchase of the Filterra® Bioretention System. Filterra is a specially engineered stormwater treatment system incorporating high performance biofiltration media to remove pollutants from stormwater runoff. The system’s biota (vegetation and soil microorganisms) then further breakdown and absorb captured pollutants. All components of the system work together to provide a sustainable long-term solution for treating stormwater runoff.

The Filterra system has been delivered to you with protection in place to resist intrusion of construction related sediment which can contaminate the biofiltration media and result in inadequate system performance. These protection devices are intended as a best practice and cannot fully prevent contamination. It is the purchaser’s responsibility to provide adequate measures to prevent construction related runoff from entering the Filterra system.

Included with your purchase is Activation of the Filterra system by the manufacturer as well as a 1-year warranty from delivery of the system and 1-year of routine maintenance (mulch replacement, debris removal, and pruning of vegetation) up to twice during the first year after activation.

Design and Installation

Each project presents different scopes for the use of Filterra systems. Information and help may be provided to the design engineer during the planning process. Correct Filterra box sizing (by rainfall region) is essential to predict pollutant removal rates for a given area. The engineer shall submit calculations for approval by the local jurisdiction. The contractor is responsible for the correct installation of Filterra units as shown in approved plans. A comprehensive installation manual is available at www.ContechES.com.

Activation Overview

Activation of the Filterra system is a procedure completed by the manufacturer to place the system into working condition. This involves the following items:

- Removal of construction runoff protection devices
- Planting of the system’s vegetation
- Placement of pretreatment mulch layer using mulch certified for use in Filterra systems.

Activation **MUST** be provided by the manufacturer to ensure proper site conditions are met for Activation, proper installation of the vegetation, and use of pretreatment mulch certified for use in Filterra systems.



Minimum Requirements

The minimum requirements for Filterra Activation are as follows:

1. The site landscaping must be fully stabilized, i.e. full landscaping installed and some grass cover (not just straw and seed) is required to reduce sediment transport. Construction debris and materials should be removed from surrounding area.



2. Final paving must be completed. Final paving ensures that paving materials will not enter and contaminate the Filterra system during the paving process, and that the plant will receive runoff from the drainage area, assisting with plant survival for the Filterra system.



3. Where curb inlets are included as part of the Filterra system, Filterra throat opening should be at least 4" in order to ensure adequate capacity for inflow and debris.

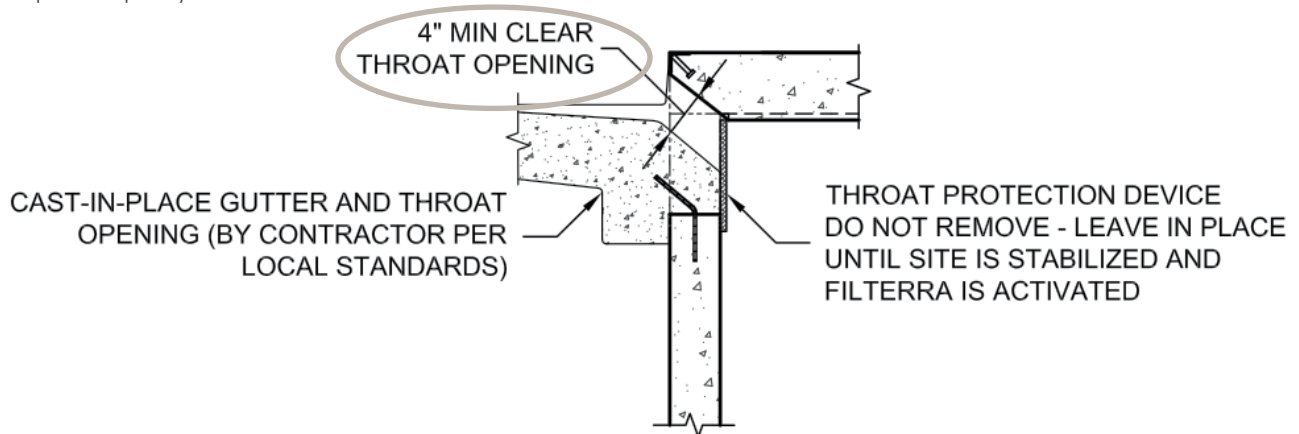

An Activation Checklist is included on page 12 to ensure proper conditions are met for Contech to perform the Activation services. A charge of \$500.00 will be invoiced for each Activation visit requested by Customer where Contech determines that the site does not meet the conditions required for Activation.

Filterra Plant Selection Overview

A Plant List is available on the Contech website highlighting recommended plants for Filterra systems in your area. Keep in mind that plants are subject to availability due to seasonality and required minimum size for the Filterra system. Plants installed in the Filterra system are container plants (max 15 gallon) from nursery stock and will be immature in height and spread at Activation.

It is the responsibility of the owner to provide adequate irrigation when necessary to the plant of the Filterra system.

The “Planting Requirements for Filterra Systems” document is included as an appendix and discusses proper selection and care of the plants within Filterra systems.

Warranty Overview

Refer to the Contech Engineered Solutions LLC Stormwater Treatment System LIMITED WARRANTY for further information. The following conditions may void the Filterra system’s warranty and waive the manufacturer provided Activation and Maintenance services:

- Unauthorized activation or performance of any of the items listed in the activation overview
- Any tampering, modifications or damage to the Filterra system or runoff protection devices
- Removal of any Filterra system components
- Failure to prevent construction related runoff from entering the Filterra system
- Failure to properly store and protect any Filterra components (including media and underdrain stone) that may be shipped separately from the vault

Routine Maintenance Guidelines

With proper routine maintenance, the biofiltration media within the Filterra system should last as long as traditional bioretention media. Routine maintenance is included by the manufacturer on all Filterra systems for the first year after activation. This includes a maximum of 2 visits to remove debris, replace pretreatment mulch, and prune the vegetation. More information is provided in the Operations and Maintenance Guidelines. Some Filterra systems also contain pretreatment or outlet bays. Depending on site pollutant loading, these bays may require periodic removal of debris, however this is not included in the first year of maintenance, and would likely not be required within the first year of operation.

These services, as well as routine maintenance outside of the included first year, can be provided by certified maintenance providers listed on the Contech website. Training can also be provided to other stormwater maintenance or landscape providers.



Why Maintain?

All stormwater treatment systems require maintenance for effective operation. This necessity is often incorporated in your property's permitting process as a legally binding BMP maintenance agreement. Other reasons to maintain are:

- Avoiding legal challenges from your jurisdiction's maintenance enforcement program.
- Prolonging the expected lifespan of your Filterra media.
- Avoiding more costly media replacement.
- Helping reduce pollutant loads leaving your property.

Simple maintenance of the Filterra is required to continue effective pollutant removal from stormwater runoff before discharge into downstream waters. This procedure will also extend the longevity of the living biofilter system. The unit will recycle and accumulate pollutants within the biomass, but is also subjected to other materials entering the inlet. This may include trash, silt and leaves etc. which will be contained above the mulch layer. Too much silt may inhibit the Filterra's flow rate, which is the reason for site stabilization before activation. Regular replacement of the mulch stops accumulation of such sediment.

When to Maintain?

Contech includes a 1-year maintenance plan with each system purchase. Annual included maintenance consists of a maximum of two (2) scheduled visits. Additional maintenance may be necessary depending on sediment and trash loading (by Owner or at additional cost). The start of the maintenance plan begins when the system is activated.

Maintenance visits are typically scheduled seasonally; the spring visit aims to clean up after winter loads including salts and sands while the fall visit helps the system by removing excessive leaf litter.

It has been found that in regions which receive between 30-50 inches of annual rainfall, (2) two visits are generally required; regions with less rainfall often only require (1) one visit per annum. Varying land uses can affect maintenance frequency; e.g. some fast food restaurants require more frequent trash removal. Contributing drainage areas which are subject to new development wherein the recommended erosion and sediment control measures have not been implemented may require additional maintenance visits.

Some sites may be subjected to extreme sediment or trash loads, requiring more frequent maintenance visits. This is the reason for detailed notes of maintenance actions per unit, helping the Supplier and Owner predict future maintenance frequencies, reflecting individual site conditions.

Owners must promptly notify the maintenance provider of any damage to the plant(s), which constitute(s) an integral part of the bioretention technology. Owners should also advise other landscape or maintenance contractors to leave all maintenance to the Supplier (i.e. no pruning or fertilizing) during the first year.



Exclusion of Services

Clean up due to major contamination such as oils, chemicals, toxic spills, etc. will result in additional costs and are not covered under the Supplier maintenance contract. Should a major contamination event occur the Owner must block off the outlet pipe of the Filterra (where the cleaned runoff drains to, such as drop inlet) and block off the throat of the Filterra. The Supplier should be informed immediately.

Maintenance Visit Summary

Each maintenance visit consists of the following simple tasks (detailed instructions below).

1. Inspection of Filterra and surrounding area
2. Removal of tree grate (where applicable) and erosion control stones
3. Removal of debris, trash and mulch
4. Mulch replacement
5. Plant health evaluation and pruning or replacement as necessary
6. Clean area around Filterra
7. Complete paperwork

Maintenance Tools, Safety Equipment and Supplies

Ideal tools include: camera, bucket, shovel, broom, pruners, hoe/rake, and tape measure. Appropriate Personal Protective Equipment (PPE) should be used in accordance with local or company procedures. This may include impervious gloves where the type of trash is unknown, high visibility clothing and barricades when working in close proximity to traffic and also safety hats and shoes. A T-Bar or crowbar should be used for moving the tree grates, where applicable (up to 170 lbs each). If tree grate opening expansion is necessary, safety glasses/goggles and a 3lb or greater mini sledgehammer are required. Most visits require minor trash removal and a full replacement of mulch. See below for actual number of bagged mulch that is required in each media bay size. Mulch should be a double shredded, hardwood variety. Some visits may require additional Filterra engineered soil media available from the Supplier.

Media Bay Length	Media Bay Width	Filter Surface Area (ft ²)	Volume at 3" (ft ³)	# of 2 ft ³ Mulch Bags
4	4	16	4	2
6	4	24	6	3
8	4	32	8	4
6	6	36	9	5
8	6	48	12	6
10	6	60	15	8
12	6	72	18	9
13	7	91	23	12

Other sizes not listed - 1 bag per 8 ft² of media.

Maintenance Visit Procedure

Keep sufficient documentation of maintenance actions to predict location specific maintenance frequencies and needs. An example Maintenance Report is included in this manual.



1. Inspection of Filterra and surrounding area

- Record individual unit before maintenance with photograph (numbered). Record on Maintenance Report (see example in this document) the following:

Record on Maintenance Report the following:

Standing Water	yes no
Damage to Box Structure	yes no
Damage to Grate (if applicable)	yes no
Is Bypass Clear	yes no

If yes answered to any of these observations, record with close-up photograph (numbered).



2. Removal of tree grate (if applicable) and erosion control stones

- Remove cast iron grates for access into Filterra box (if applicable).
- Dig out silt (if any) and mulch and remove trash & foreign items.

3. Removal of debris, trash and mulch

Record on Maintenance Report the following:

Silt/Clay	yes no
Cups/ Bags	yes no
Leaves	yes no
Buckets Removed	_____



- After removal of mulch and debris, measure distance from the top of the Filterra engineered media soil to the top of the top slab. Compare the measured distance to the distance shown on the approved Contract Drawings for the system. Add Filterra media (not top soil or other) to bring media up as needed to distance indicated on drawings.

Record on Maintenance Report the following:

Distance to Top of Top Slab (inches)	_____
Inches of Media Added	_____



4. Mulch replacement

- Add double shredded mulch evenly across the entire unit to a depth of 3".
- Refer to Filterra Mulch Specifications for information on acceptable sources.
- Ensure correct repositioning of erosion control stones by the Filterra inlet to allow for entry of trash during a storm event.
- Replace Filterra grates (if applicable) correctly using appropriate lifting or moving tools, taking care not to damage the plant.
- Where applicable, if 6" tree grate opening is too close to plant trunk, the grate opening may be expanded to 12" using a mini sledgehammer. Refer to instructions in Appendix 3.



5. Plant health evaluation and pruning or replacement as necessary

- Examine the plant's health and replace if necessary.
- Prune as necessary to encourage growth in the correct directions

Record on Maintenance Report the following:

Height above top of Filterra Unit	_____ (ft)
Width at Widest Point	_____ (ft)
Health	healthy unhealthy
Damage to Plant	yes no
Plant Replaced	yes no



6. Clean area around Filterra

- Clean area around unit and remove all refuse to be disposed of appropriately.



7. Complete paperwork

- Deliver Maintenance Report and photographs to appropriate location (normally Contech during maintenance contract period).
- Some jurisdictions may require submission of maintenance reports in accordance with approvals. It is the responsibility of the Owner to comply with local regulations.

Maintenance Checklist

Drainage System Failure	Problem	Conditions to Check	Condition that Should Exist	Actions
Inlet	Excessive sediment or trash accumulation.	Accumulated sediments or trash impair free flow of water into Filterra.	Inlet should be free of obstructions allowing free distributed flow of water into Filterra.	Sediments and/or trash should be removed.
Mulch Cover	Trash and floatable debris accumulation.	Excessive trash and/or debris accumulation.	Minimal trash or other debris on mulch cover.	Trash and debris should be removed and mulch cover raked level. Ensure bark nugget mulch is not used.
Mulch Cover	"Ponding" of water on mulch cover.	"Ponding" in unit could be indicative of clogging due to excessive fine sediment accumulation or spill of petroleum oils.	Stormwater should drain freely and evenly through mulch cover.	Recommend contact manufacturer and replace mulch as a minimum.
Vegetation	Plants not growing or in poor condition.	Soil/mulch too wet, evidence of spill. Incorrect plant selection. Pest infestation. Vandalism to plants.	Plants should be healthy and pest free.	Contact manufacturer for advice.
Vegetation	Plant growth excessive.	Plants should be appropriate to the species and location of Filterra.		Trim/prune plants in accordance with typical landscaping and safety needs.
Structure	Structure has visible cracks.	Cracks wider than 1/2 inch or evidence of soil particles entering the structure through the cracks.		Vault should be repaired.

Maintenance is ideally to be performed twice annually.

Filterra Inspection & Maintenance Log

Filterra System Size/Model: _____ Location: _____

Date	Mulch & Debris Removed	Depth of Mulch Added	Mulch Brand	Height of Vegetation Above Top of Vault	Vegetation Species	Issues with System	Comments
1/1/17	5 – 5 gal Buckets	3"	Lowe's Premium Brown Mulch	4'	Galaxy Magnolia	- Standing water in downstream structure	- Removed blockage in downstream structure

Appendix 1 – Filterra® Activation Checklist



Project Name: _____ Company: _____

Site Contact Name: _____ Site Contact Phone/Email: _____

Site Owner/End User Name: _____ Site Owner/End User Phone/Email: _____

Preferred Activation Date: _____ (provide 2 weeks minimum from date this form is submitted)

Site Designation	System Size	Final Pavement / Top Coat Complete	Landscaping Complete / Grass Emerging	Construction materials / Piles / Debris Removed	Throat Opening Measures 4" Min. Height	Plant Species Requested
		<input type="checkbox"/> Yes <input type="checkbox"/> No	<input type="checkbox"/> Yes <input type="checkbox"/> No	<input type="checkbox"/> Yes <input type="checkbox"/> No	<input type="checkbox"/> Yes <input type="checkbox"/> No <input type="checkbox"/> N/A	
		<input type="checkbox"/> Yes <input type="checkbox"/> No	<input type="checkbox"/> Yes <input type="checkbox"/> No	<input type="checkbox"/> Yes <input type="checkbox"/> No	<input type="checkbox"/> Yes <input type="checkbox"/> No <input type="checkbox"/> N/A	
		<input type="checkbox"/> Yes <input type="checkbox"/> No	<input type="checkbox"/> Yes <input type="checkbox"/> No	<input type="checkbox"/> Yes <input type="checkbox"/> No	<input type="checkbox"/> Yes <input type="checkbox"/> No <input type="checkbox"/> N/A	
		<input type="checkbox"/> Yes <input type="checkbox"/> No	<input type="checkbox"/> Yes <input type="checkbox"/> No	<input type="checkbox"/> Yes <input type="checkbox"/> No	<input type="checkbox"/> Yes <input type="checkbox"/> No <input type="checkbox"/> N/A	
		<input type="checkbox"/> Yes <input type="checkbox"/> No	<input type="checkbox"/> Yes <input type="checkbox"/> No	<input type="checkbox"/> Yes <input type="checkbox"/> No	<input type="checkbox"/> Yes <input type="checkbox"/> No <input type="checkbox"/> N/A	
		<input type="checkbox"/> Yes <input type="checkbox"/> No	<input type="checkbox"/> Yes <input type="checkbox"/> No	<input type="checkbox"/> Yes <input type="checkbox"/> No	<input type="checkbox"/> Yes <input type="checkbox"/> No <input type="checkbox"/> N/A	
		<input type="checkbox"/> Yes <input type="checkbox"/> No	<input type="checkbox"/> Yes <input type="checkbox"/> No	<input type="checkbox"/> Yes <input type="checkbox"/> No	<input type="checkbox"/> Yes <input type="checkbox"/> No <input type="checkbox"/> N/A	
		<input type="checkbox"/> Yes <input type="checkbox"/> No	<input type="checkbox"/> Yes <input type="checkbox"/> No	<input type="checkbox"/> Yes <input type="checkbox"/> No	<input type="checkbox"/> Yes <input type="checkbox"/> No <input type="checkbox"/> N/A	
		<input type="checkbox"/> Yes <input type="checkbox"/> No	<input type="checkbox"/> Yes <input type="checkbox"/> No	<input type="checkbox"/> Yes <input type="checkbox"/> No	<input type="checkbox"/> Yes <input type="checkbox"/> No <input type="checkbox"/> N/A	

Attach additional sheets as necessary.

NOTE: A charge of \$500.00 will be invoiced for each Activation visit requested by Customer where Contech determines that the site does not meet the conditions required for Activation. ONLY Contech authorized representatives can perform Activation of Filterra systems; unauthorized Activations will void the system warranty and waive manufacturer supplied Activation and 1st Year Maintenance.

Signature _____

Date _____

Appendix 2 – Planting Requirements for Filterra® Systems

Plant Material Selection

- Select plant(s) as specified in the engineering plans and specifications.
- Select plant(s) with full root development but not to the point where root bound.
- Use local nursery container plants only. Ball and burlapped plants are not permitted.
- For precast Filterra systems with a tree grate, plant(s) must not have scaffold limbs at least 14 inches from the crown due to spacing between the top of the mulch and the tree grate. Lower branches can be pruned away provided there are sufficient scaffold branches for tree or shrub development.
- For precast Filterra systems with a tree grate, at the time of installation, it is required that plant(s) must be at least 6" above the tree grate opening at installation for all Filterra configurations. This DOES NOT apply to Full Grate Cover designs.
- Plant(s) shall not have a mature height greater than 25 feet.
- For standard 21" media depth, a 7 – 15 gallon container size shall be used. Media less than 21" (Filterra boxes only) may require smaller container plants.
- For precast Filterra systems, plant(s) should have a single trunk at installation, and pruning may be necessary at activation and maintenance for some with a tree grate of the faster growing species, or species known to produce basal sprouts.

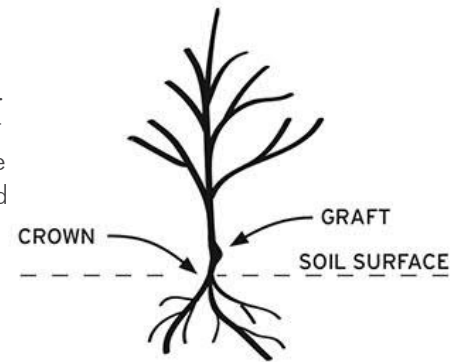

Plant Installation

- During transport protect the plant foliage from wind and excessive jostling.
- Prior to removing the plant(s) from the container, ensure the soil moisture is sufficient to maintain the integrity of the root ball. If needed, pre-wet the container plant.
- Cut away any roots which are growing out of the container drain holes. Plants with excessive root growth from the drain holes should be rejected.
- Plant(s) should be carefully removed from the pot by gently pounding on the sides of the container with the fist to loosen root ball. Then carefully slide out. Do not lift plant(s) by trunk as this can break roots and cause soil to fall off. Extract the root ball in a horizontal position and support it to prevent it from breaking apart. Alternatively the pot can be cut away to minimize root ball disturbance.
- Remove any excess soil from above the root flare after removing plant(s) from container.
- Excavate a hole with a diameter 4" greater than the root ball, gently place the plant(s).
- If plant(s) have any circling roots from being pot bound, gently tease them loose without breaking them.
- If root ball has a root mat on the bottom, it should be shaved off with a knife just above the mat line.
- Plant the tree/shrub/grass with the top of the root ball 1" above surrounding media to allow for settling.
- All plants should have the main stem centered in the tree grate (where applicable) upon completion of installation.
- With all trees/shrubs, remove dead, diseased, crossed/rubbing, sharply crotched branches or branches growing excessively long or in wrong direction compared to majority of branches.
- To prevent transplant shock (especially if planting takes place in the hot season), it may be necessary to prune some of the foliage to compensate for reduced root uptake capacity. This is accomplished by pruning away some of the smaller secondary branches or a main scaffold branch if there are too many. Too much foliage relative to the root ball can dehydrate and damage the plant.
- Plant staking may be required.

Mulch Installation

- Only mulch that meets Contech Engineered Solutions' mulch specifications can be used in the Filterra system.
- Mulch must be applied to a depth of 3" evenly over the surface of the media.

Irrigation Requirements

- Each Filterra system must receive adequate irrigation to ensure survival of the living system during periods of drier weather.
- Irrigation sources include rainfall runoff from downspouts and/or gutter flow, applied water through the top/tree grate or in some cases from an irrigation system with emitters installed during construction.
- At Activation: Apply about one (cool climates) to two (warm climates) gallons of water per inch of trunk diameter over the root ball.
- During Establishment: In common with all plants, each Filterra plant will require more frequent watering during the establishment period. One inch of applied water per week for the first three months is recommended for cooler climates (2 to 3 inches for warmer climates). If the system is receiving rainfall runoff from the drainage area, then irrigation may not be needed. Inspection of the soil moisture content can be evaluated by gently brushing aside the mulch layer and feeling the soil. Be sure to replace the mulch when the assessment is complete. Irrigate as needed**.
- Established Plants: Established plants have fully developed root systems and can access the entire water column in the media. Therefore irrigation is less frequent but requires more applied water when performed. For a mature system assume 3.5 inches of available water within the media matrix. Irrigation demand can be estimated as 1" of irrigation demand per week. Therefore if dry periods exceed 3 weeks, irrigation may be required. It is also important to recognize that plants which are exposed to windy areas and reflected heat from paved surfaces may need more frequent irrigation. Long term care should develop a history which is more site specific.

** Five gallons per square yard approximates 1 inch of water Therefore for a 6' by 6' Filterra approximately 20-60 gallons of water is needed. To ensure even distribution of water it needs to be evenly sprinkled over the entire surface of the filter bed, with special attention to make sure the root ball is completely wetted. NOTE: if needed, measure the time it takes to fill a five gallon bucket to estimate the applied water flow rate then calculate the time needed to irrigate the Filterra. For example, if the flow rate of the sprinkler is 5 gallons/minute then it would take 12 minutes to irrigate a 6' by 6' filter.



Appendix 3 – Filterra® Tree Grate Opening Expansion Procedure

The standard grates used on all Filterra configurations that employ Tree Grates are fabricated with a 6" opening that is designed with a breakaway section that can be removed, allowing the grate opening to be expanded to 12" as the tree matures and the trunk widens.

The following tools are required to expand the opening:

- Mini sledgehammer (3 lb. or greater)
- Safety Glasses / Goggles

The following guidelines should be followed to properly expand the tree opening from 6" to 12":



1. Remove the grate from the Filterra frame, place it flat on a hard surface, and support the grate by stepping on the edge or using other weighted items such as a few mulch bags if this is being done during a Filterra maintenance event. Put on safety glasses/goggles. Align the mini sledgehammer as shown in the figure to the left. The head of the sledgehammer should be aimed just inside the wide cast iron bar between the larger grate section and the breakaway section.

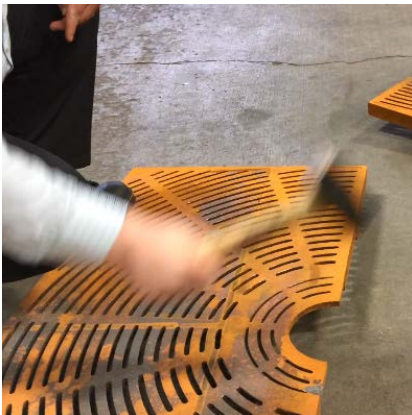

2. Repeatedly hit the grate at this spot with the mini sledgehammer.



3. After several hits, the breakaway section should snap cleanly off of the larger grate section. Reinstall the grate into the Filterra grate frame. Recycle or dispose of the breakaway section per local guidelines.



9025 Centre Pointe Drive, Suite 400
West Chester, OH 45069
info@conteches.com | 800-338-1122
www.ContechES.com

© 2021 Contech Engineered Solutions LLC, a QUIKRETE Company

ALL RIGHTS RESERVED. PRINTED IN THE USA.

NOTHING IN THIS CATALOG SHOULD BE CONSTRUED AS A WARRANTY. APPLICATIONS SUGGESTED HEREIN ARE DESCRIBED ONLY TO HELP READERS MAKE THEIR OWN EVALUATIONS AND DECISIONS, AND ARE NEITHER GUARANTEES NOR WARRANTIES OF SUITABILITY FOR ANY APPLICATION. CONTECH MAKES NO WARRANTY WHATSOEVER, EXPRESS OR IMPLIED, RELATED TO THE APPLICATIONS, MATERIALS, COATINGS, OR PRODUCTS DISCUSSED HEREIN. ALL IMPLIED WARRANTIES OF MERCHANTABILITY AND ALL IMPLIED WARRANTIES OF FITNESS FOR ANY PARTICULAR PURPOSE ARE DISCLAIMED BY CONTECH. SEE CONTECH'S CONDITIONS OF SALE (AVAILABLE AT WWW.CONTECHES.COM/COS) FOR MORE INFORMATION.