

# OPERATION & MAINTENANCE MANUAL

## Underground Injection Control System: Drywell

Manual Prepared: February 2023

DFI No. D01530

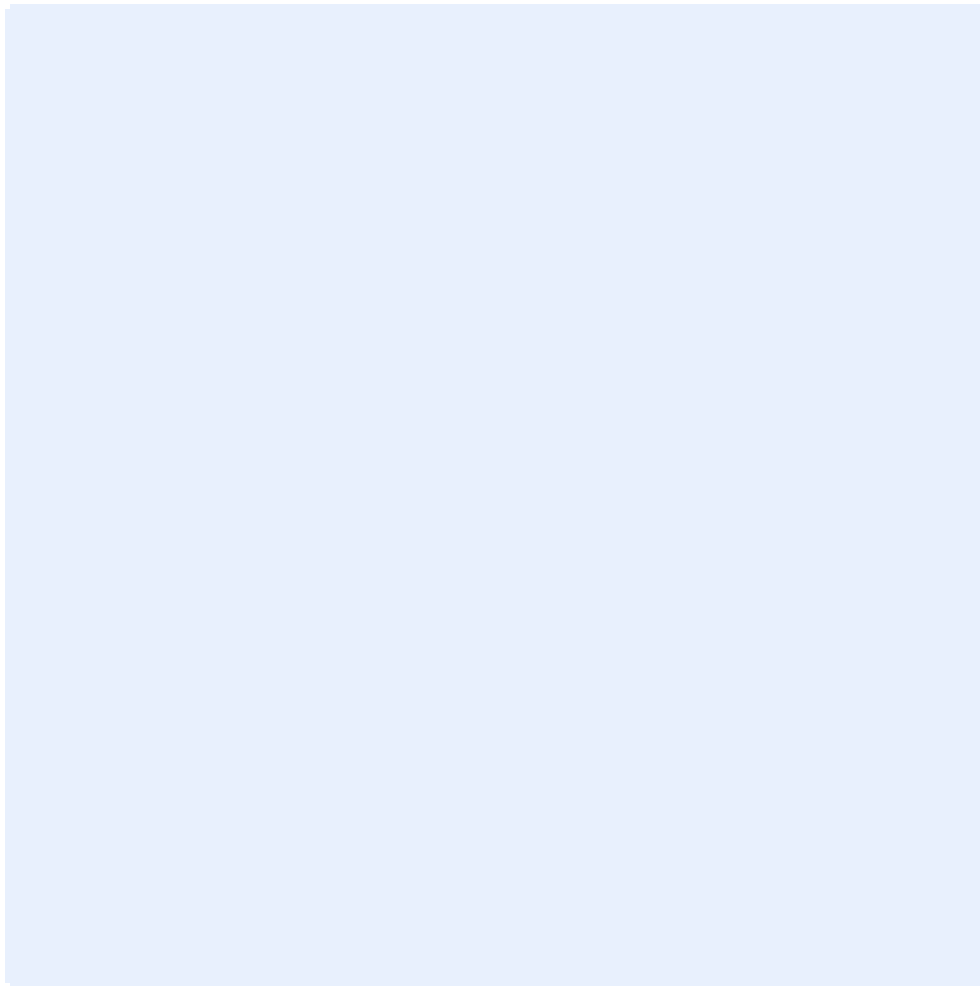

Figure 1: DFI No. D01530, looking [note cardinal direction]

## Identification

Drainage Facility ID (DFI): D01530  
Facility Type: (2) Drywells with pretreatment sedimentation manhole, flow splitter, and shut-off gate valve  
Construction Drawings: (V-File Numbers) 56V-055  
Location: District: 2B  
Highway No.: 068  
Mile Post: 7.4, Median

### 1. Manual Purpose

The purpose of this manual is to outline inspection needs and summarize maintenance actions for drywells and system components.

### 2. Facility Location

The location map below details the facility location. The highway, mile posts, side streets, access location, and stormwater flow directions are noted on the map.

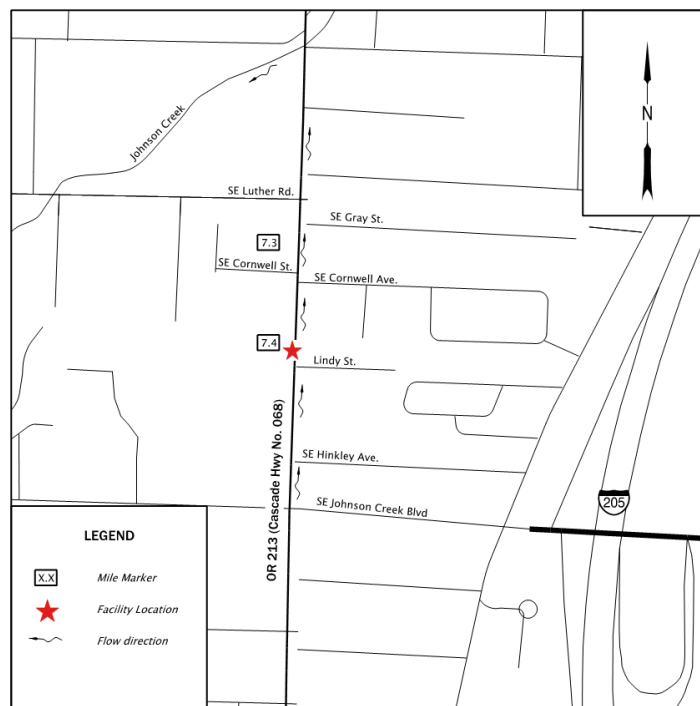

Figure 2: Facility Location Map

### 3. Facility Summary

This drywell is considered an Underground Injection Control system (UIC). The drywell structure allows stormwater to infiltrate into the surrounding soil. This process of infiltration through the drywell structure also removes pollutants from the stormwater.

Generally, drainage systems that outlet to a drywell also include inlets, pipes, pre-treatment manholes/structures to remove trash and debris, a shutoff valve, and the drywell structure. Drywells typically include manholes with perforated barrels, drain rock, and drainage geotextile.

Drywells are accessible via a manhole lid and can be identified by the Type S3 facility field markers shown below.

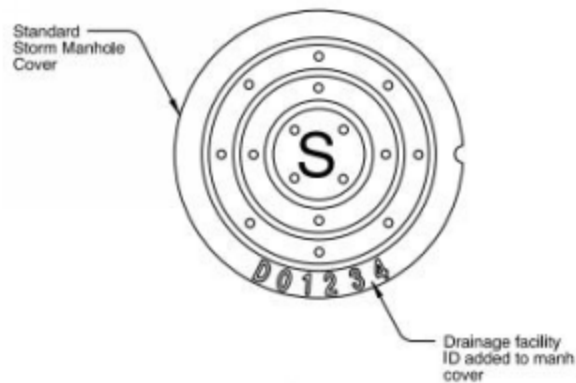

Figure 3: Type S3 Stormwater Facility Field Marker

| Diameter (Feet) | Drywell Bottom Depth (Feet) | Drain Rock (CUYD) |
|-----------------|-----------------------------|-------------------|
| 4               | 30                          | ±17               |
| 4               | 30                          | ±17               |

- Does this facility contain pretreatment BMPs? Yes
  - If yes, please specify type: Sedimentation manhole
- Depth to Groundwater Table: ±41 feet
- Groundwater Surface Elevation: ±185 feet

- Is there a well within 500 feet of the drywell? No

**Site Specific Information**

This facility is an underground facility with manhole access. located within the center turn lane of OR 213 (Cascade Hwy. No. 068). High flows from larger storm events will bypass the flow splitter manhole and continue through a pipe network to ultimately outfall directly into Johnson Creek. This facility is comprised of four major components with connecting storm pipes, see Appendix A. The components include 1) a flow splitter manhole to siphon off stormwater under a water quality storm event and allow high flows to bypass the system 2) a sedimentation manhole as a pretreatment mechanism to collect debris and sediment prior to entering the infiltration sump, and 3) two infiltration sumps with perforated walls to infiltrate the runoff into the surrounding soils. The facility receives OR 213 runoff from both northbound and southbound lanes through a 36-inch diameter inlet pipe which connects to the flow splitter manhole. Low flows will be conveyed with a 12-inch diameter storm pipe to the sedimentation manhole for pretreatment, then conveyed to the infiltration sump.

**Facility Access**

Maintenance access to the facility:

|                                                                        |                                                   |
|------------------------------------------------------------------------|---------------------------------------------------|
| <input type="checkbox"/> Roadside pad                                  | <input type="checkbox"/> Roadside shoulder        |
| <input type="checkbox"/> Access road with Gate                         | <input type="checkbox"/> Access road without Gate |
| <input checked="" type="checkbox"/> Roadway median                     | <input type="checkbox"/> Lane closure needed      |
| <input type="checkbox"/> Other Access (specify below in photo caption) |                                                   |

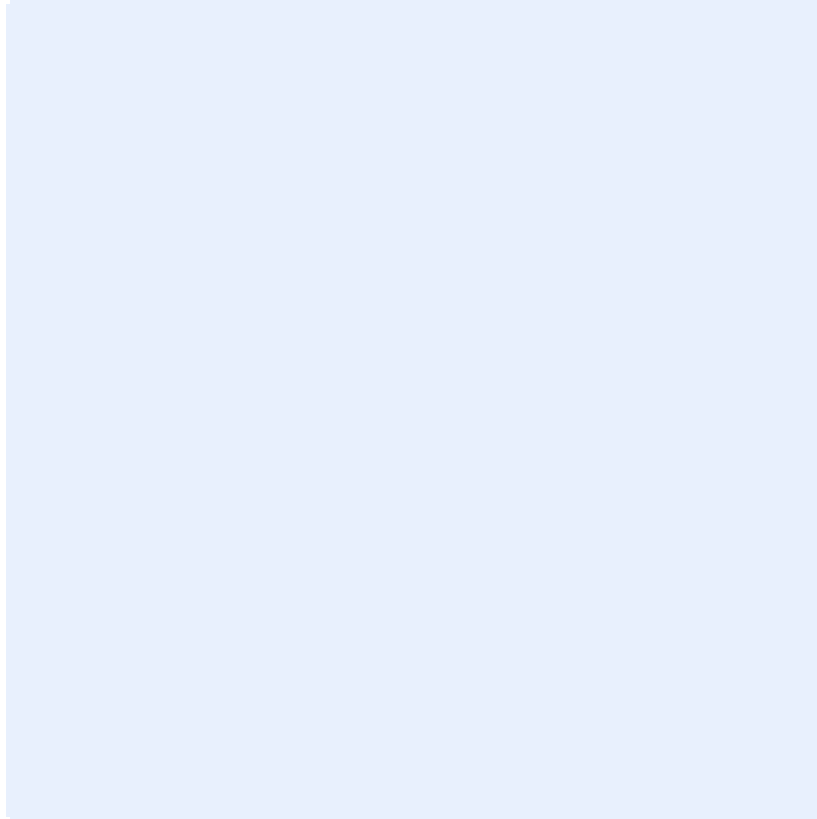

**Figure 4:** [insert post construction facility access photo and caption text]

## **4. Operational Components / Maintenance Items**

### **Operational Components**

The facility components table (**Table 1**) highlights the applicable components for this facility. The component is included in this facility when the box contains an “x” (e.g. ☒ ).

### **Operational Plan**

See Appendix A for the site specific operational plan.

### Key Features/Items:

This facility includes an overflow bypass component.

| <input type="checkbox"/> No                                                              | <input checked="" type="checkbox"/> Yes                                                                                                          |
|------------------------------------------------------------------------------------------|--------------------------------------------------------------------------------------------------------------------------------------------------|
| There is no bypass component. High flows drain into and infiltrate through the facility. | There is an overflow bypass component. Under large storm events, the drywell may overflow to other facilities. See Operational Plan for details. |

### Maintenance Items

Operational components marked in **Table 1** should be inspected and maintained according to Section 7. Each facility component is defined and detailed in the Standard Operation Manual using the associated ID number indicated below.

| Table 1: Drywell Components                            |                                     | ID #       |
|--------------------------------------------------------|-------------------------------------|------------|
| <b>Upstream Manholes/Structures</b>                    |                                     |            |
| Flow Splitter Manhole                                  | <input checked="" type="checkbox"/> | <b>D1</b>  |
| Pre-treatment Structure<br>Type: Sedimentation manhole | <input checked="" type="checkbox"/> | <b>D2</b>  |
| Shutoff Valve: Butterfly Valve                         | <input checked="" type="checkbox"/> | <b>D3</b>  |
| Drywell                                                | <input checked="" type="checkbox"/> | <b>D4</b>  |
| <b>Facility Inlet</b>                                  |                                     |            |
| Inlet Pipe(s)                                          | <input checked="" type="checkbox"/> | <b>D5</b>  |
| <b>Ground Cover</b>                                    |                                     |            |
| Common Fill                                            | <input type="checkbox"/>            | <b>D6</b>  |
| <b>Underground Components</b>                          |                                     |            |
| Geotextile Fabric: Drainage geotextile                 | <input checked="" type="checkbox"/> | <b>D7</b>  |
| Granular Drain Rock                                    | <input checked="" type="checkbox"/> | <b>D8</b>  |
| Perforated Pipe:                                       | <input type="checkbox"/>            | <b>D9</b>  |
| <b>Facility Outlet</b>                                 |                                     |            |
| Infiltration                                           | <input checked="" type="checkbox"/> | <b>D10</b> |
| High Flow Bypass                                       | <input checked="" type="checkbox"/> | <b>D11</b> |
| Storm Sewer System                                     | <input type="checkbox"/>            | <b>D12</b> |

### Unique Tools for Component Testing

- a. Valve key (for shutoff valve testing)

## 5. Facility Hazardous Material Spill Feature(s)

The drywell cannot be used to store a volume of hazardous liquid. All hazardous material must be blocked prior to entering the drywell. The hazardous material can be blocked by turning off the valve between the pollution control manhole and the drywell. The valve requires a valve key to turn the valve off and on.

## 6. Maintenance

### Maintenance Frequency/Maintain Records

- a. Inspect annually, preferably prior to the rainy season.
- b. Clean and maintain as necessary. Refer to Activity 125 for conditions when maintenance is needed.
- c. Keep a record of inspections, maintenance, and repairs.
- d. Open and close any shutoff valves annually.

### Maintenance Guide/Maintenance Actions

The ODOT Maintenance Guide lists the standard maintenance actions for water quality facilities under Activity 125.

Standard maintenance tables describe the maintenance component, the potential defect or problem, the condition when maintenance is needed, and the recommended maintenance to correct the problem. Use the following tables to maintain ODOT drywells:

- Table 8: Underground Injection Controls (UICs)

The *Blue Book* can be viewed at the following website:

[https://www.oregon.gov/odot/Maintenance/Documents/blue\\_book.pdf](https://www.oregon.gov/odot/Maintenance/Documents/blue_book.pdf)

## 7. Limitations

- Confined Space Entry
  - a. All personnel who need to enter the drywell for maintenance, inspection, or any other reason must be trained and certified in confined space entry.

## 8. Material Disposal

Material removed from the facility is defined as waste by the Department of Environmental Quality (DEQ). Refer to the road waste section of the ODOT Maintenance Yard Environmental Management System (EMS) Policy and Procedures Manual for disposal options:

[http://www.oregon.gov/ODOT/Maintenance/Documents/ems\\_manual.pdf](http://www.oregon.gov/ODOT/Maintenance/Documents/ems_manual.pdf)

Contact any of the following for more detailed information about management of waste materials found on site:

|                                       |                |
|---------------------------------------|----------------|
| ODOT Materials Management Coordinator | (503) 731-8493 |
| ODOT Statewide Hazmat Coordinator     | (503) 667-7442 |
| ODOT Region 1 Hazmat Coordinator      | (503) 731-8290 |
| ODOT Region 2 Hazmat Coordinator      | (503) 986-2647 |
| ODOT Region 3 Hazmat Coordinator      | (541) 957-3594 |
| ODOT Region 4 Hazmat Coordinator      | (541) 388-6186 |
| ODOT Region 5 Hazmat Coordinator      | (541) 963-1590 |
| ODEQ Northwest Region Office          | (503) 229-5263 |



## **A Appendix A – Site Specific Operational Plan**

### **Contents:**

**Operational Plan: DFI D01530**

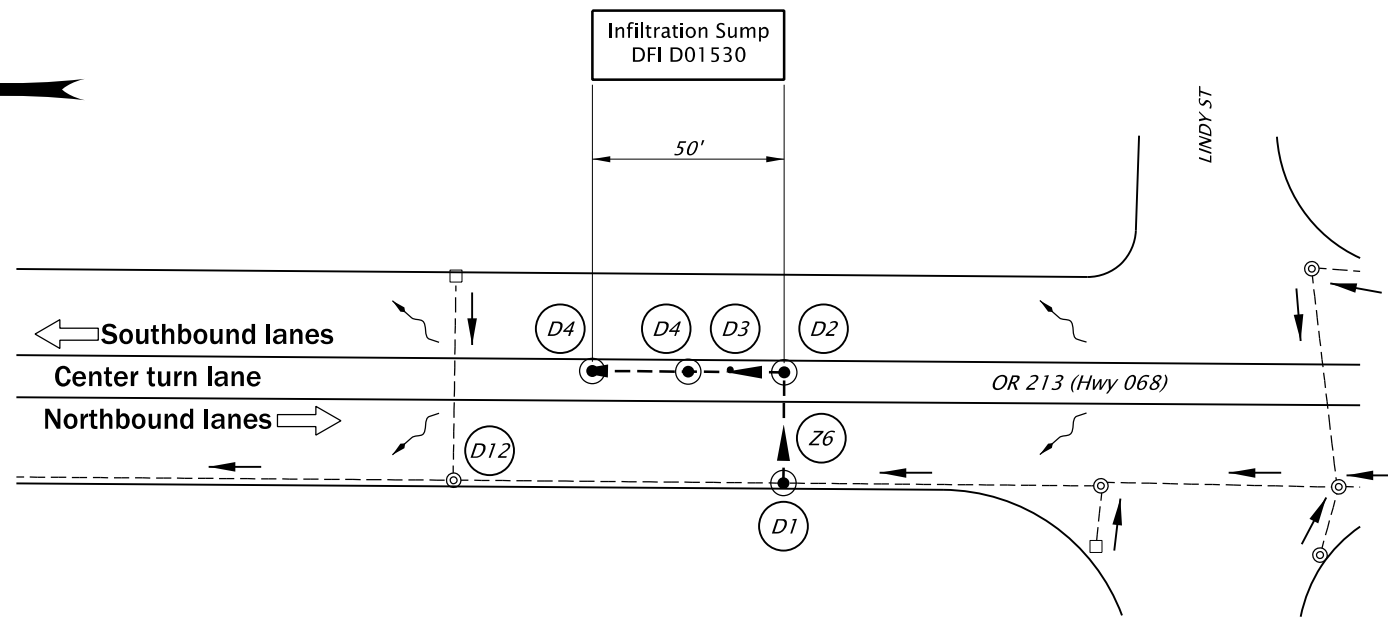
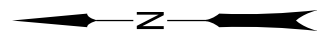

**PLAN**  
Not to Scale

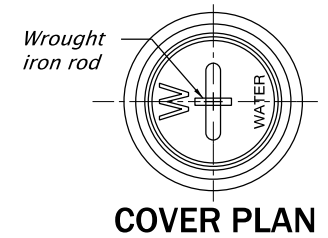

**COVER PLAN**

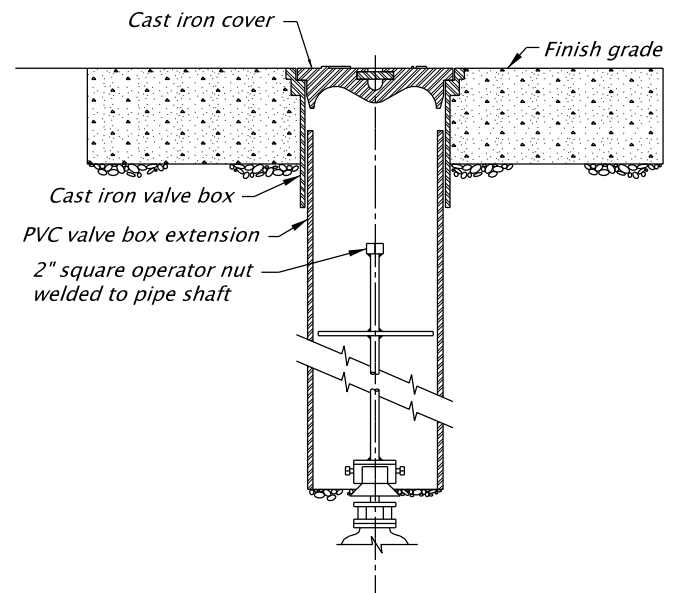

**VALVE BOX EXTENSION SECTION**

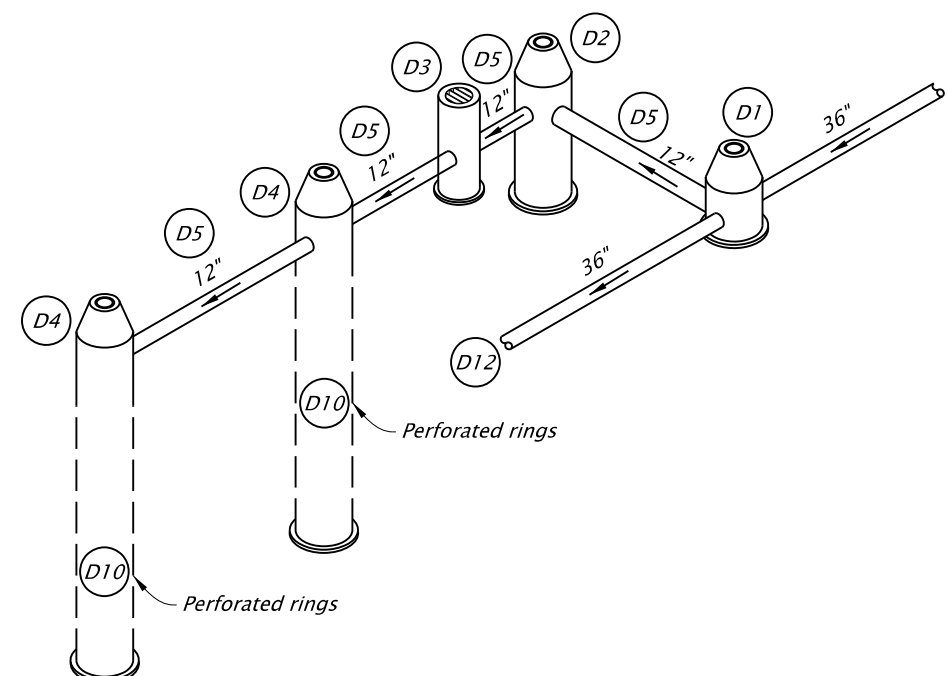

**SUMP SYSTEM SCHEMATIC**  
Not to Scale

**LEGEND**

- X# Facility component (see table 1 in O&M Manual)
- and  Manhole
- and  Inlet
- Shut-off Valve
- Storm pipe (facility)
- Storm pipe
- Conveyance direction
- Pavement / facility flow path
- Traffic flow direction



**OREGON DEPARTMENT OF TRANSPORTATION**

Sht. 1 of 2

Prepared By:  
Eric Webster

Drafted By:  
Eric Webster

**DFI D01530**  
**MAINTENANCE DISTRICT 2B HWY 068**  
**INFILTRATION SUMP SYSTEM**  
HIGHWAY MP 7.4  
CLACKAMAS COUNTY

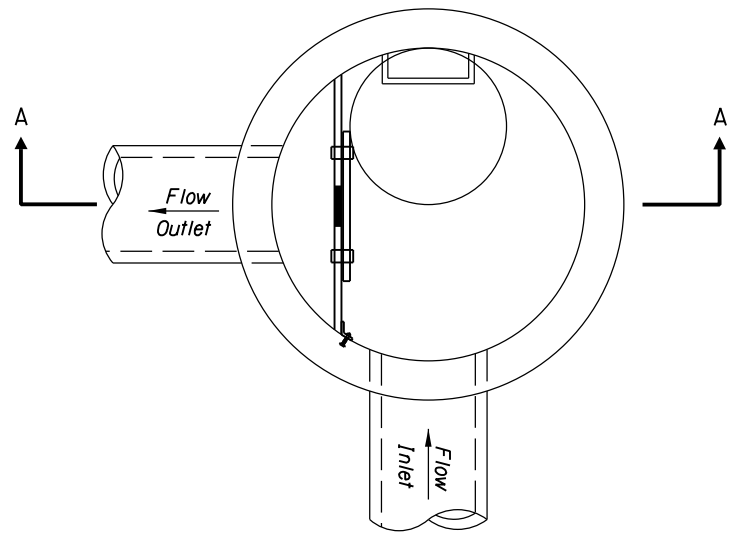

PLAN

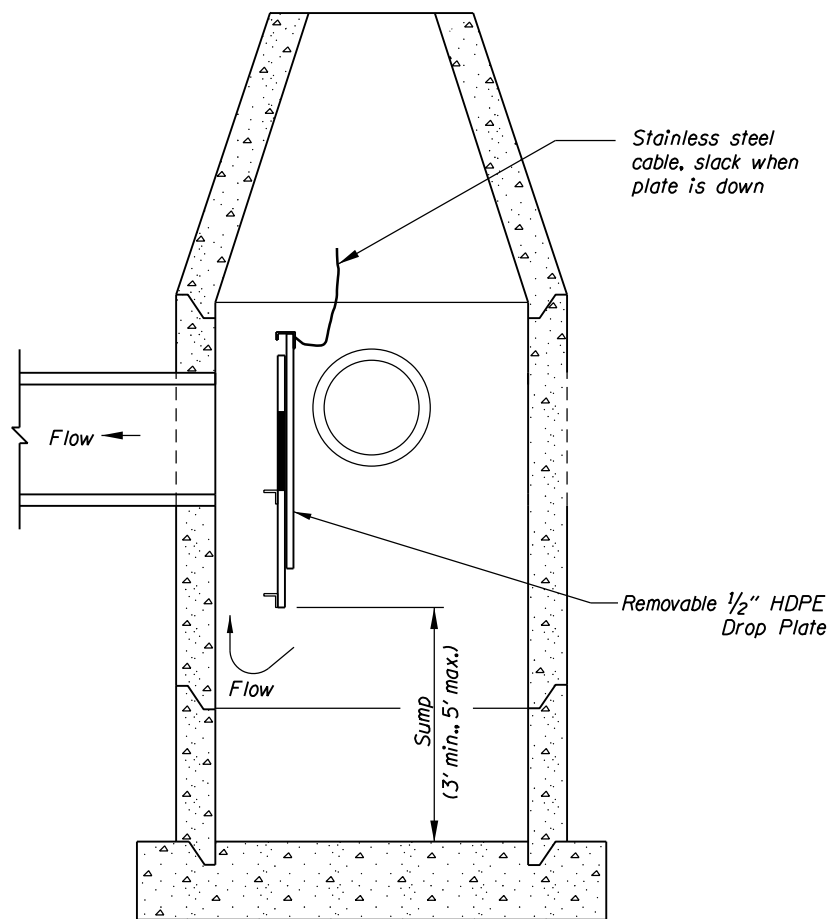

SECTION A-A

**D2 Sedimentation Manhole**  
Not to Scale

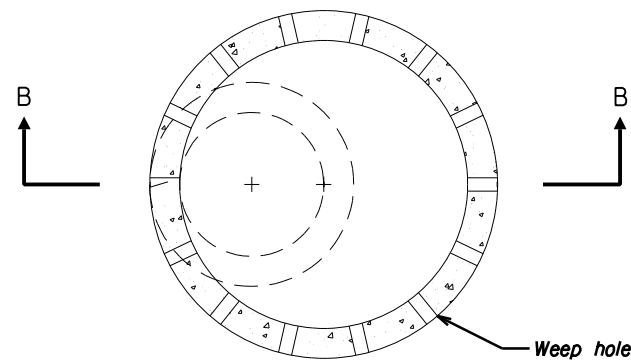

PLAN

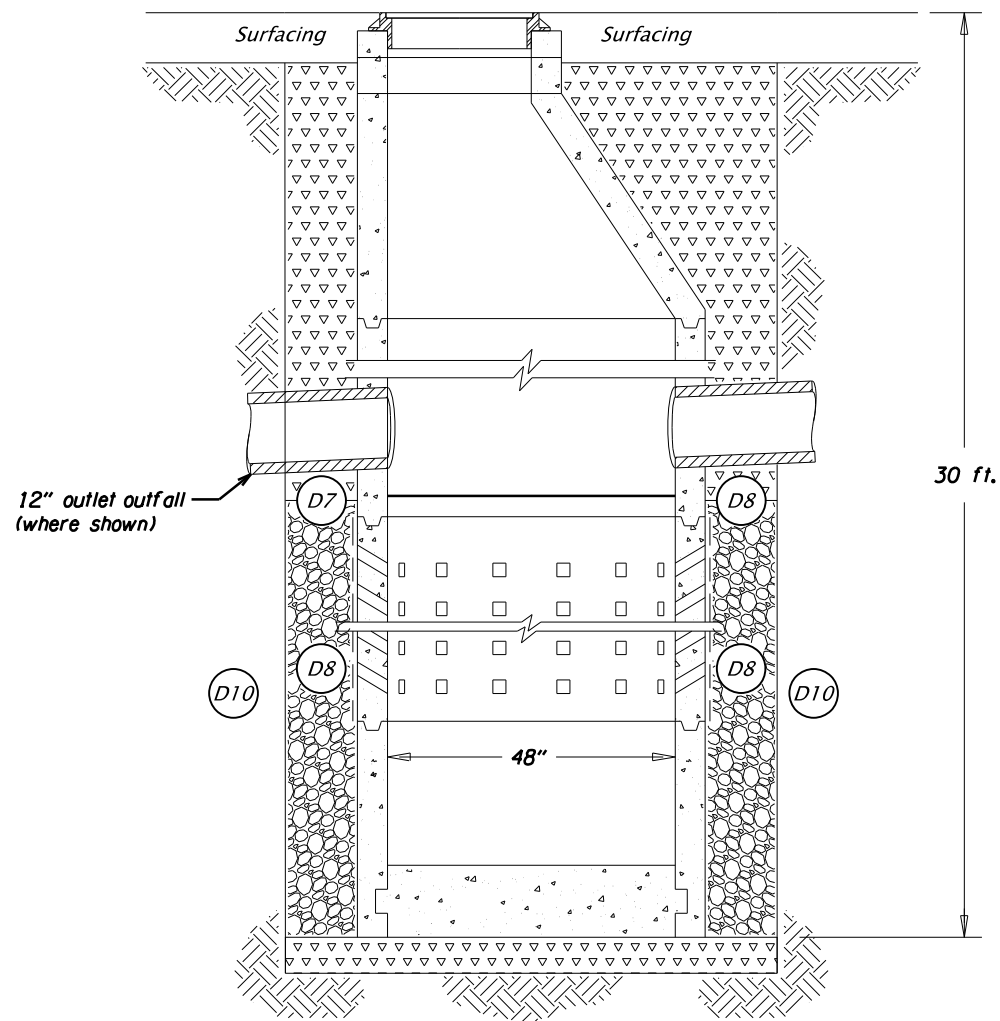

SECTION B-B

**D4 Infiltration Sump**  
Not to Scale

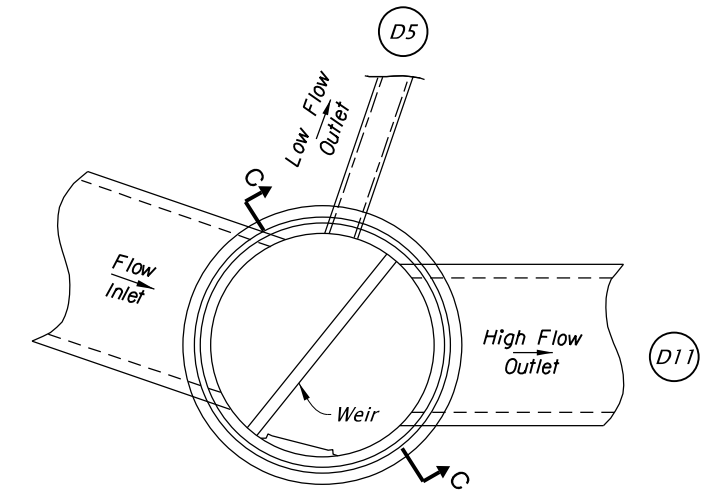

PLAN

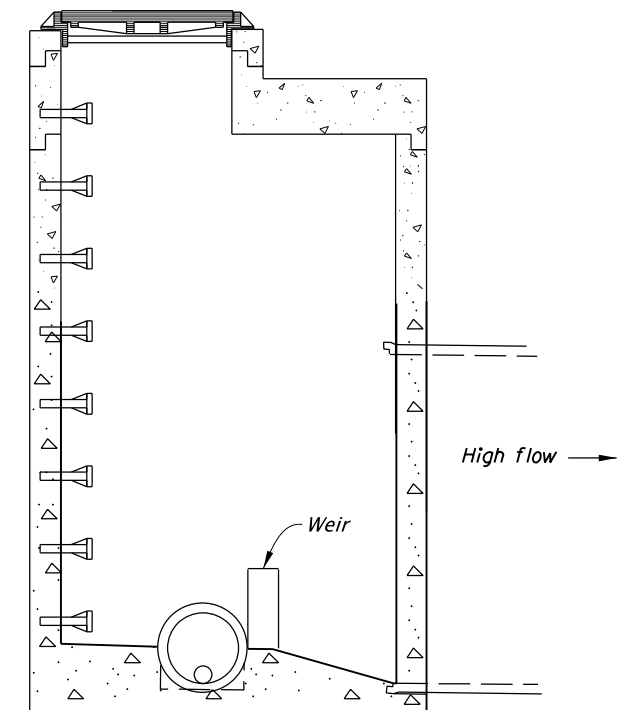

SECTION C-C

**D1 Flow Splitter Manhole**  
Not to Scale

Sht. 2 of 2

Prepared By:  
Eric Webster  
Drafted By:  
Eric Webster



OREGON DEPARTMENT OF TRANSPORTATION

**DFI D01530**  
**MAINTENANCE DISTRICT 2B HWY 068**  
**INFILTRATION SUMP SYSTEM**  
HIGHWAY MP 7.4  
CLACKAMAS COUNTY

## **B Appendix B – Project Contract Plans**

### **Contents:**

**Site Specific Subset of Project Contract Plan 56V-055**

| INDEX OF SHEETS |                         |
|-----------------|-------------------------|
| SHEET NO.       | DESCRIPTION             |
| A01             | Title Sheet             |
| A02             | Index Of Sheets Cont'd. |
| A03             | Std. Dwg. Nos.          |

STATE OF OREGON  
**DEPARTMENT OF TRANSPORTATION**

PLANS FOR PROPOSED PROJECT  
**GRADING, PAVING, CURB RAMPS, SIGNING,  
 SIGNALS & ILLUMINATION**

**OR213 (82ND AVE):  
 SE FOSTER RD - SE THOMPSON RD SEC.**

**CASCADE HIGHWAY NORTH**

**CLACKAMAS & MULTNOMAH COUNTIES**

**MAY 2023**

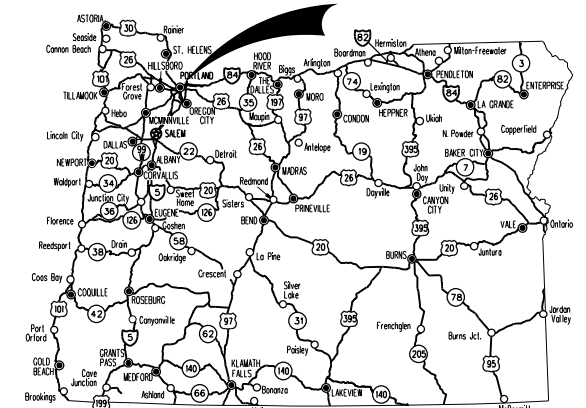

Overall Length Of Project - 2.78 Miles

**ATTENTION:**  
 Oregon Law Requires You To Follow Rules  
 Adopted By The Oregon Utility Notification  
 Center. Those Rules Are Set Forth In  
 OAR 952-001-0010 Through OAR 952-001-0090.  
 You May Obtain Copies Of The Rules By Calling  
 The Center. (Note: The Telephone Number For  
 The Oregon Utility Center Is (503) 232-1987.)



**BEGINNING OF PROJECT**

**STA. "L" 254+67 (M.P. 5.76)**

**NO WORK AREA**

**STA. "L" 341+00 (M.P. 7.41) TO  
 STA. "L" 373+75 (M.P. 8.03)**

**NO WORK AREA**

**STA. "L" 377+50 (M.P. 8.10) TO  
 STA. "L" 395+90 (M.P. 8.45)**



**PROJECT LOCATION**

**M.P. 8.06**

**PROJECT LOCATION**

**M.P. 8.50**

**END OF PROJECT**

**STA. "L" 400+00 (M.P. 8.52)**

North Arrow  
 T. 1 S., R. 2 E., W.M.



PLANS PREPARED FOR  
 OREGON DEPARTMENT OF TRANSPORTATION  
 101 SW Main Street, Suite 1000  
 Portland, OR 97204  
 P 503.225.9010



OREGON TRANSPORTATION COMMISSION

- Robert Van Brocklin CHAIR
- Julie Brown VICE CHAIR
- Sharon Smith COMMISSIONER
- Lee Beyer COMMISSIONER
- Vacant COMMISSIONER
- Kristopher W. Strickler DIRECTOR OF TRANSPORTATION

These plans were developed using ODOT design standards. Exceptions to these standards, if any, have been submitted and approved by the ODOT Chief Engineer or their delegated authority.

Consultant Principal: **Kevin M Thelin** Date: 2023.02.16 10:36:52-08'00'  
 Signature & date  
 Kevin Thelin, PE, Chief Transportation Engineer  
 Print name and title

Concurrence by ODOT Chief Engineer

**OR213 (82ND AVE):  
 SE FOSTER RD - SE THOMPSON RD SEC.  
 CASCADE HIGHWAY NORTH  
 CLACKAMAS & MULTNOMAH COUNTIES**

|                                |                |           |
|--------------------------------|----------------|-----------|
| FEDERAL HIGHWAY ADMINISTRATION | PROJECT NUMBER | SHEET NO. |
| OREGON DIVISION                | S068(031)      | A01       |

PE002904-000-J71

**BEGINNING OF NO WORK AREA**  
**STA. "L" 341+00 (MP 7.41)**

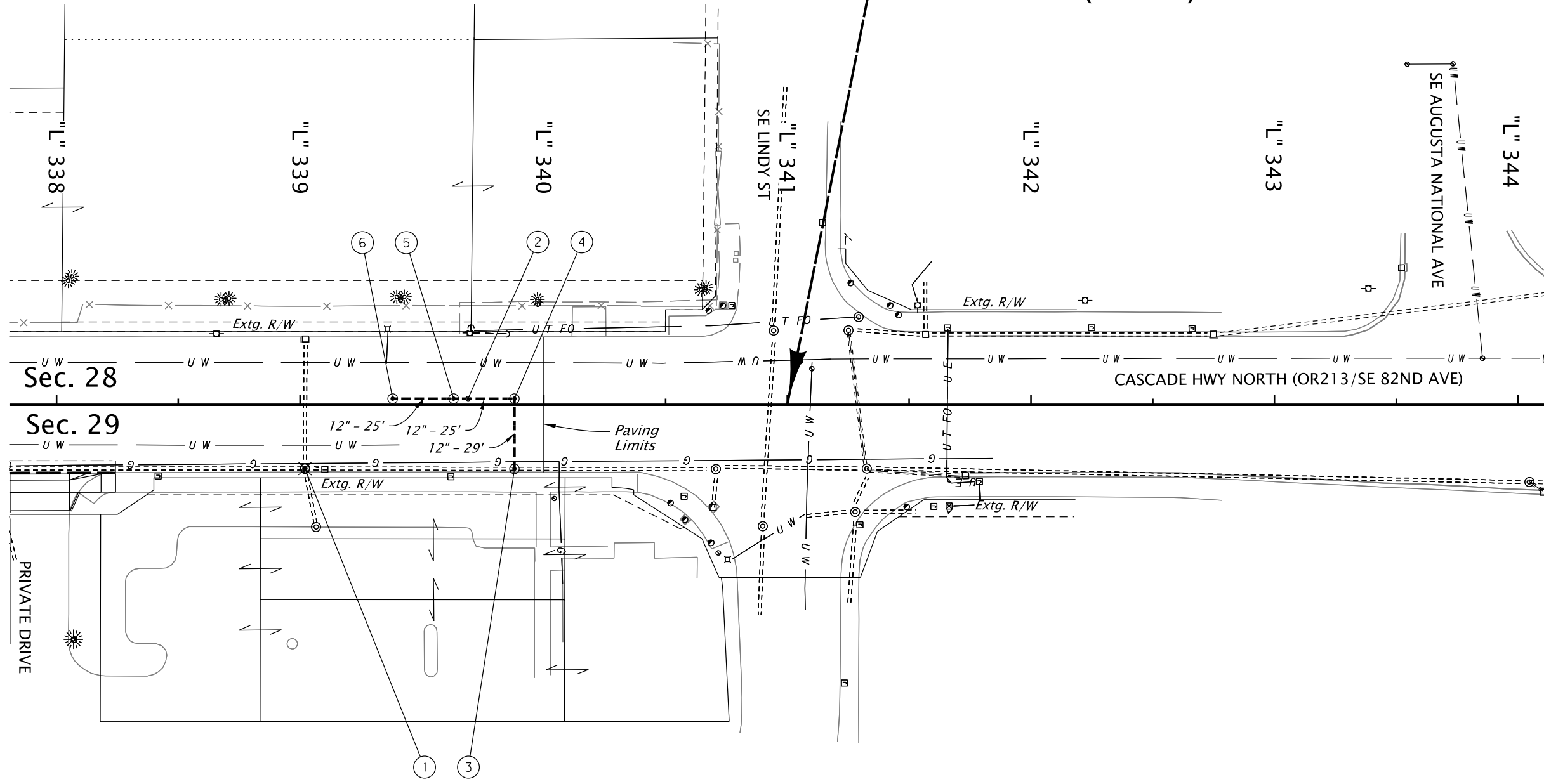

- ① Minor adjust manhole  
Method "C" circular cut
- ② Sta. "L" 339+69.0, 2.5' Lt.  
Inst. 12" butterfly valve  
(For details, see sht. HA 08)
- ③ Sta. "L" 339+88.0, 26.3' Rt.  
Const. 72" diversion manhole  
Extra for manhole over extg. sewer  
(For details, see sht. HA03)
- ④ Sta. "L" 339+88.0, 2.5' Lt.  
Const. sedimentation manhole  
Type A  
Inst. 12" storm sew. pipe - 29'  
10' depth  
Install field facility marker, Type S3  
Trench resurfacing - 10 sq. yd.  
(For details, see sht. HA04)
- ⑤ Sta. "L" 339+63.0, 2.5' Lt.  
Const. Sump, 30' depth  
with sump capacity test  
Inst. 12" storm sew. pipe - 25'  
10' depth  
Install field facility marker, Type S3  
Trench resurfacing - 8 sq. yd.  
(For details, see sht. HA05 & HA07)
- ⑥ Sta. "L" 339+38.0, 2.5' Lt.  
Const. Sump, 30' depth  
with sump capacity test  
Inst. 12" storm sew. pipe - 25'  
10' depth  
Trench resurfacing - 8 sq. yd.  
Install field facility marker, Type S3  
(For details, see sht. HA05 & HA07)

**LEGEND**  
 (Items in legend may not appear on plans)

- Remove manhole:
- Adjust sew. manhole:
- Adjust san. manhole:
- Const. manhole:
- Remove inlet:
- Adjust inlet:
- Const. inlet:
- Const. pipe:
- Abandon/remove pipe:
- Inst. butterfly valve:

REGISTERED PROFESSIONAL  
**ENGINEER**  
 80521PE  
 DIGITALLY SIGNED 2023.02.16  
 14:26:36-08'00'  
 OREGON  
 MAY 14, 2013  
**TYLER SHAWN NORD**

RENEWS: 12-31-2024

**consor**

**OR213 (82ND AVE):**  
**SE FOSTER RD - SE THOMPSON RD SEC.**  
 CASCADE HIGHWAY NORTH  
 CLACKAMAS & MULTNOMAH COUNTIES

Designer: Austin Morey      Reviewer: Kevin Thelin  
 Drafter: Scott Failmezger      Checker: Tyler Nord

**DRAINAGE & UTILITIES**

SHEET NO.  
C15B

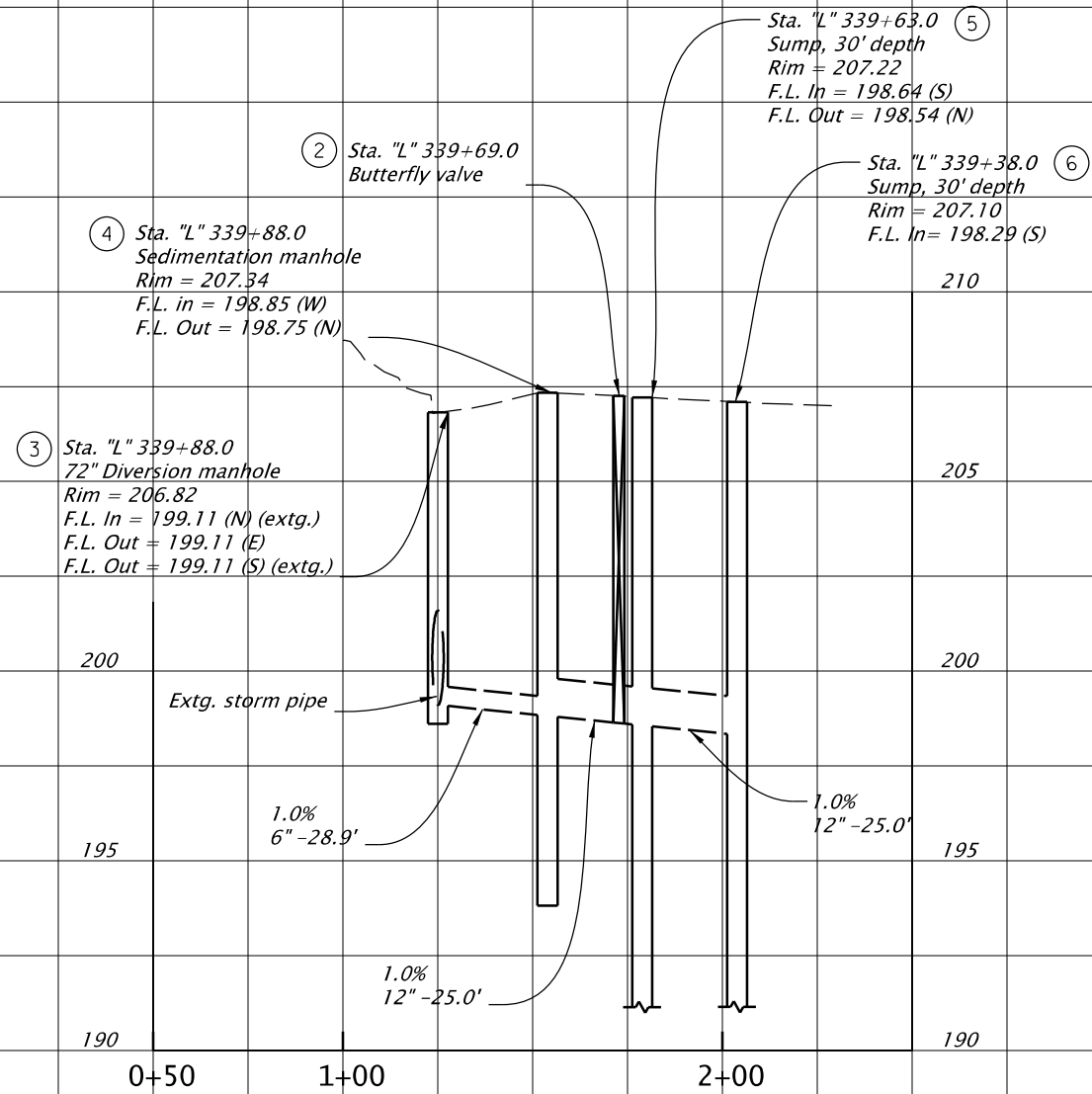

PROFILE ALONG PIPE CENTERLINE NORTH OF LINDY ST (MEDIAN)

Notes:

1. Existing utility shown elevations are approximate and for information only

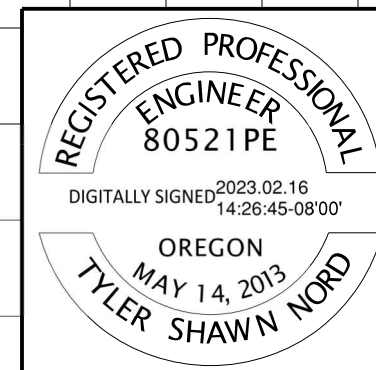

RENEWALS: 12-31-2024



OR213 (82ND AVE):  
SE FOSTER RD - SE THOMPSON RD SEC.  
CASCADE HIGHWAY NORTH  
CLACKAMAS & MULTNOMAH COUNTIES

Designer: Austin Morey Reviewer: Tyler Nord  
Drafter: Serge Chernishoff Checker: Tyler Nord

DRAINAGE PROFILES

SHEET NO. C15C

D I V E R S I O N M A N H O L E  
 " L " 3 3 9 + 8 8 , 2 6 ' R T .

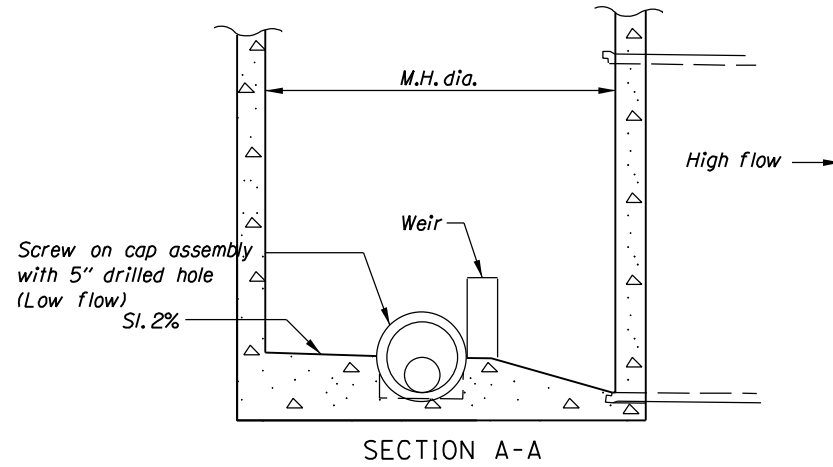
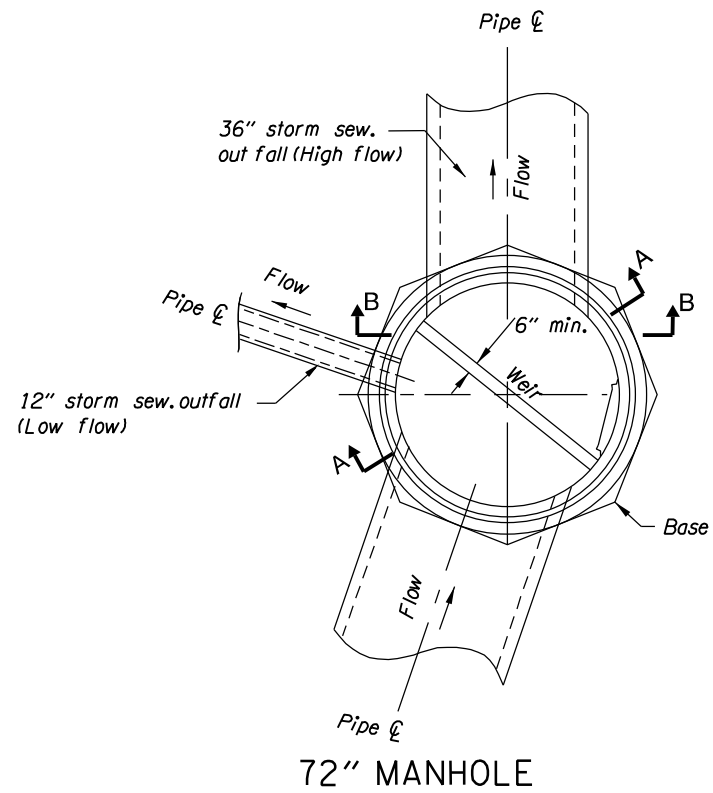

SPLIT FLOW MANHOLE

(For details not shown, see dwg. nos. RD340 & RD346)

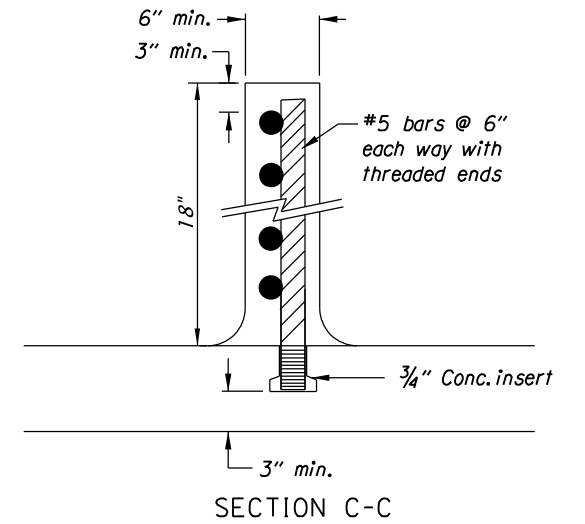
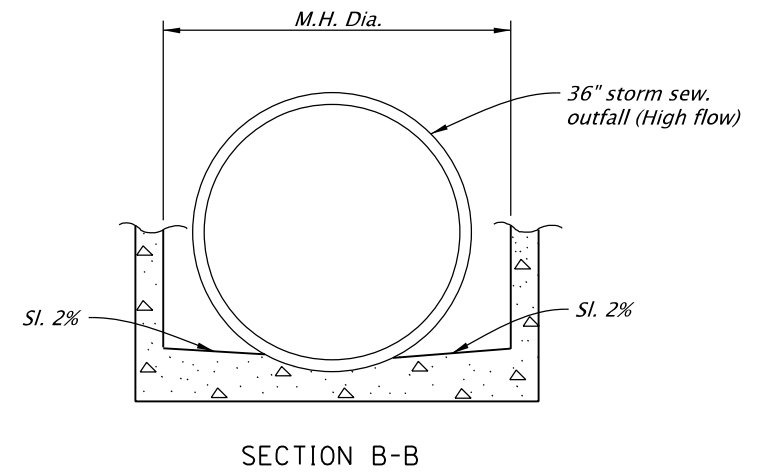

\*\* Drawing Not to Scale \*\*

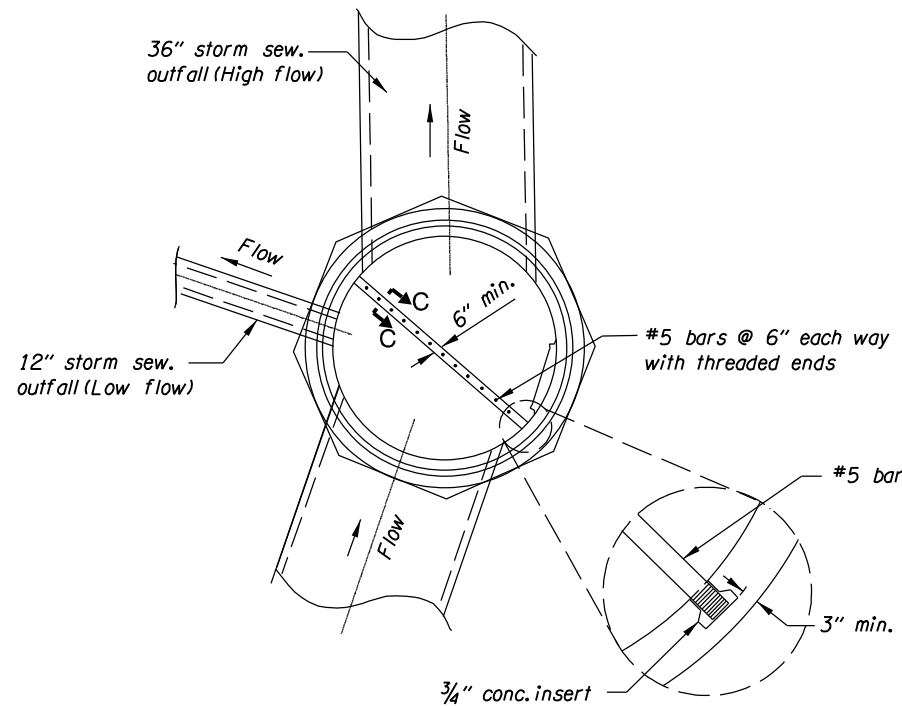

REGISTERED PROFESSIONAL  
 ENGINEER  
 93797PE  
 DIGITALLY SIGNED 2023.02.16 12:21:17-08'00'  
 OREGON  
 JULY 10, 2018  
 ERIC R. WEBSTER  
 RENEWS: 06-30-2024

**consor**

OR213 (82ND AVE):  
 SE FOSTER RD - SE THOMPSON RD SEC.  
 CASCADE HIGHWAY NORTH  
 CLACKAMAS & MULTNOMAH COUNTIES

Designer: Eric Webster      Reviewer: Kevin Thelin  
 Drafter: Fouad Elgharabli      Checker: Tyler Nord

**DETAILS**      SHEET NO. HA03



SEDIMENTATION MANHOLE  
TYPE A

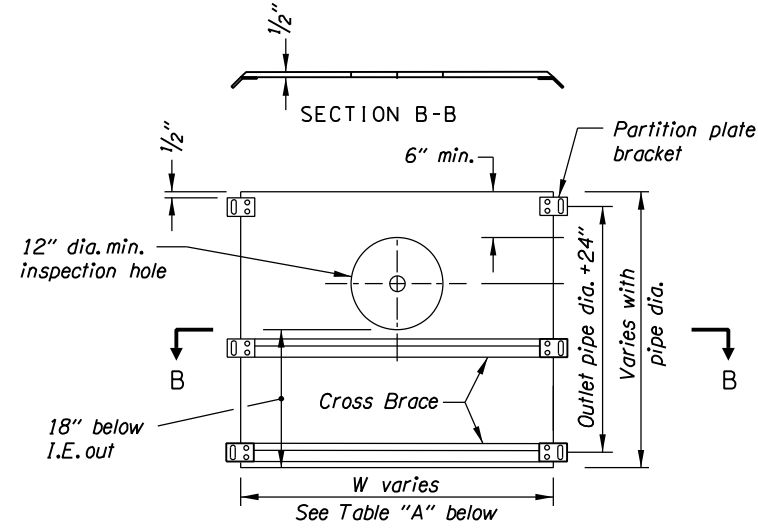
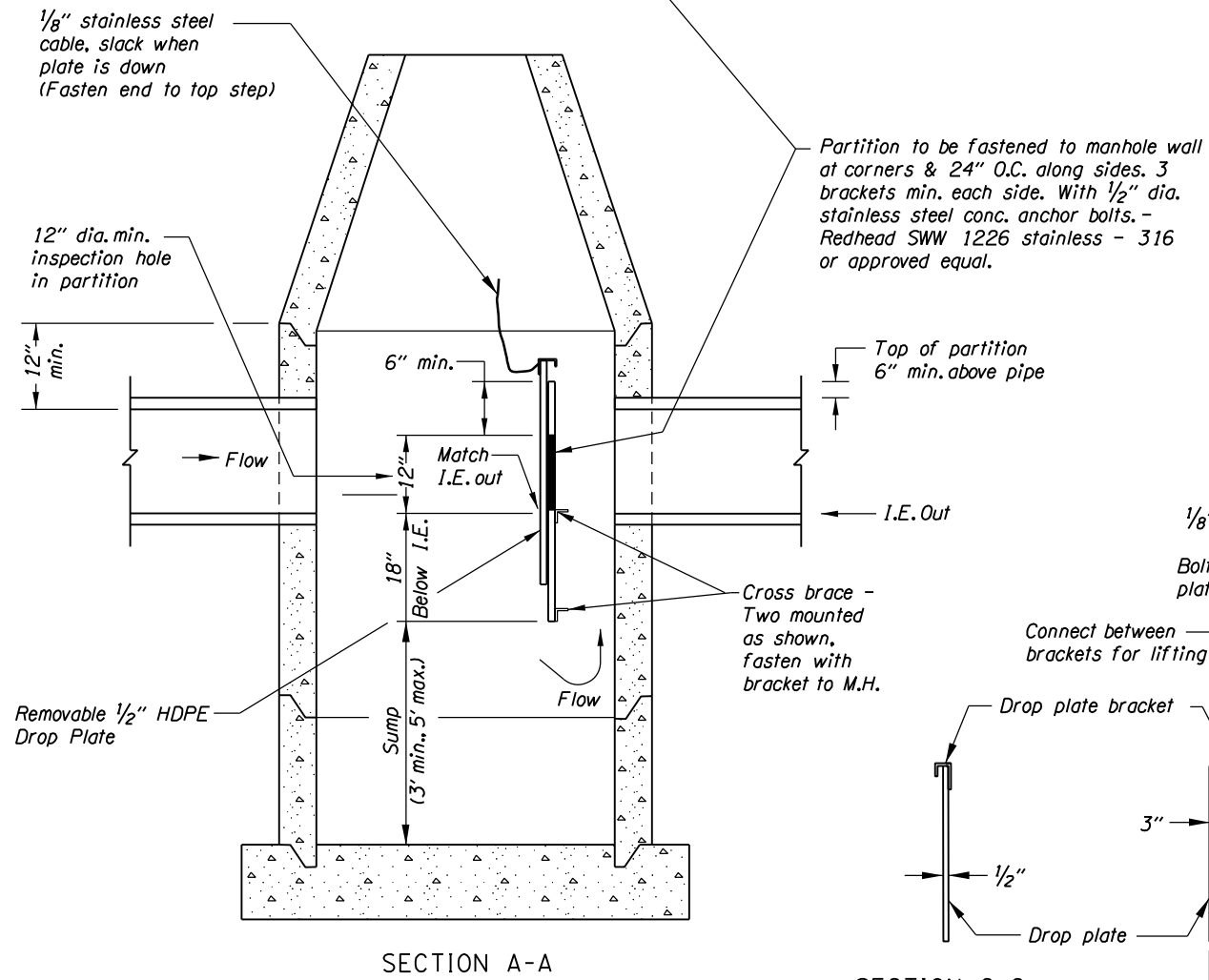
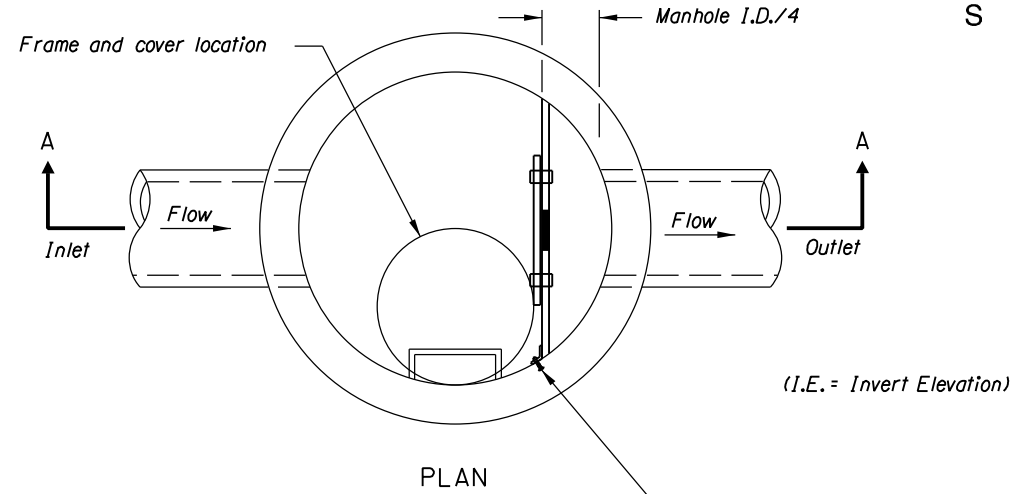

PARTITION PLATE

TABLE "A"

| M.H. Dia. (in) | W (in) |
|----------------|--------|
| 48             | 42     |
| 54             | 47     |
| 60             | 52     |
| 72             | 62     |
| 96             | 83     |

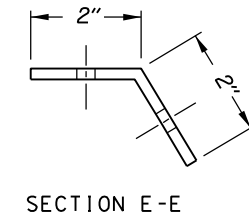

(1/8" stainless steel)  
PARTITION PLATE BRACKET

GENERAL NOTES FOR ALL DETAILS:

1. Hardware, fasteners and anchors to be stainless steel; use 1/8" stainless steel cable.
2. See pipe data sheet and plan sheets for pipe sizes(s).
3. See pipe data sheet and plan sheets for manhole sizes(s).
4. See pipe data sheet and plan sheets for sump depth.
5. Removable drop plate and partition to be constructed of High Density Polyethylene (HDPE), 1/2" thick ASTM D1248-78 and installed prior to manhole cone or top.
6. Manhole and pipe connection details per manhole standard drawings.
7. Cross brace L 2 1/2" x 1 1/2" x 3/16" grade 316 stainless steel. Two per partition plate - Full width. Fasten to partition with stainless bolt, nut & washer at 18" ctrs. Fasten to M.H. at ends using partition plate brackets.
8. Hardware, fasteners, anchors, fittings, appurtenances, labor and equipment is incidental to sedimentation manhole item.
9. See std. dwg. RD335 for manhole with precast flat slab top option.

\*\* Drawing Not to Scale \*\*

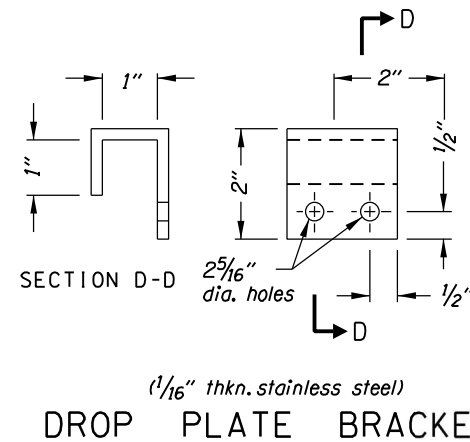
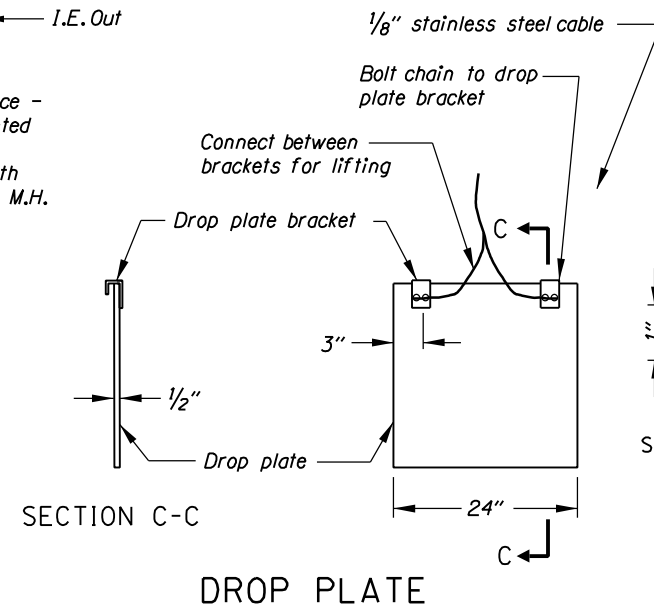

(For details not shown, see dwg. nos. RD340 & RD346)



RENEWS: 06-30-2024



OR213 (82ND AVE):  
SE FOSTER RD - SE THOMPSON RD SEC.  
CASCADE HIGHWAY NORTH  
CLACKAMAS & MULTNOMAH COUNTIES

Designer: Eric Webster  
Drafter: Fouad Elgharabli

Reviewer: Kevin Thelin  
Checker: Tyler Nord

DETAILS

SHEET NO.  
HA04

P R E C A S T S U M P

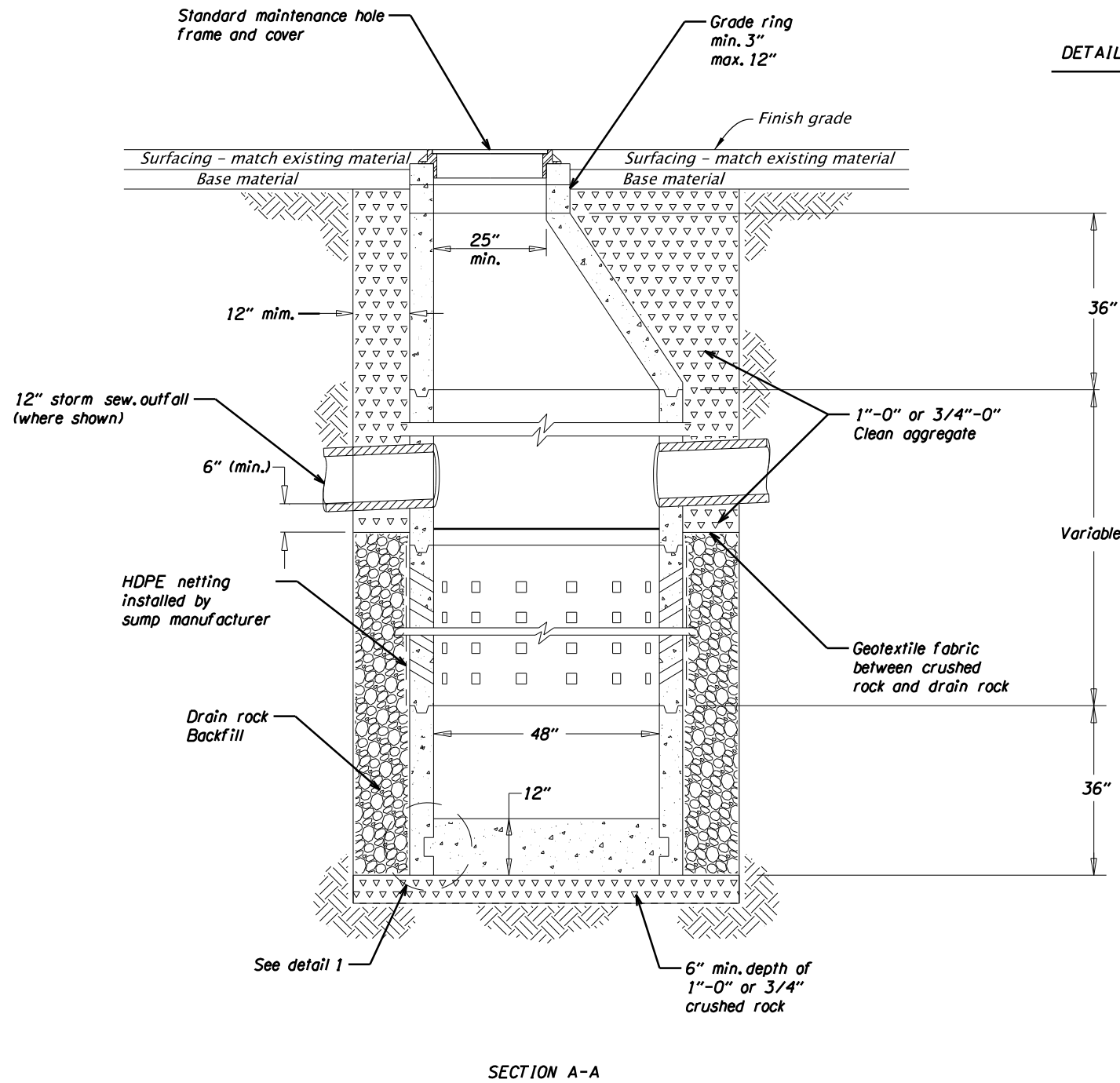
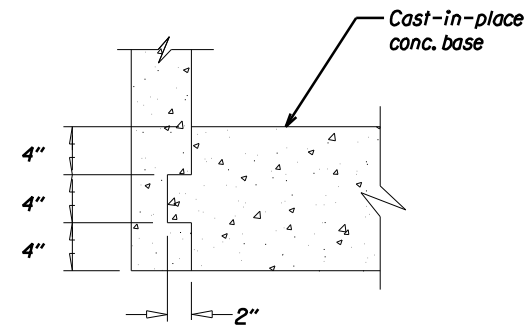
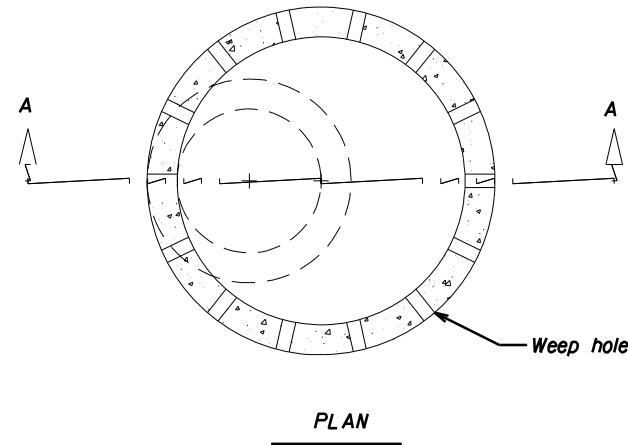

Notes:

1. All precast sections shall confirm to the requirements of ASTM C478.
2. Manhole and pipe connection details per manhole standard drawings.
3. See pipe data sheet and plan sheet for pipe size(s).
4. Provide 1"-0" or 3/4"-0" clean crushed aggregate under all connecting pipe.
5. Do not connect pipe to any perforated section. Provide 48" of separation between the cone base and any weep holes.
6. Cast-in-place concrete shall be bevel and smooth. A precast concrete base may be substituted for the base shown.
7. Provide 12" min. of separation between a section joint and the outer edge of any opening.
8. Hardware, fasteners, anchors, fittings, appurtenances, labor, and equipment is incidental to drywell item.
9. Install valve box and operator extension assembly where indicated. See std. dwg. RD 258 for details not shown.

\*\* Drawing Not to Scale \*\*

Sheet included in  
City of Portland  
Public Works Permit



RENEWS: 06-30-2024



OR213 (82ND AVE):  
SE FOSTER RD - SE THOMPSON RD SEC.  
CASCADE HIGHWAY NORTH  
CLACKAMAS & MULTNOMAH COUNTIES

Designer: Eric Webster      Reviewer: Kevin Thelin  
Drafter: Fouad Elgharabli      Checker: Tyler Nord

DETAILS

SHEET NO.  
HA05

V A L V E B O X A N D O P E R A T O R  
E X T E N S I O N A S S E M B L Y

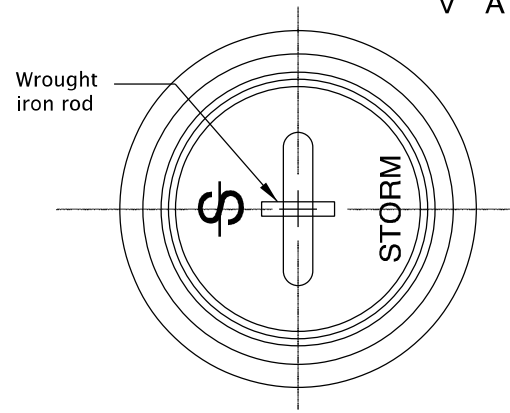

COVER PLAN

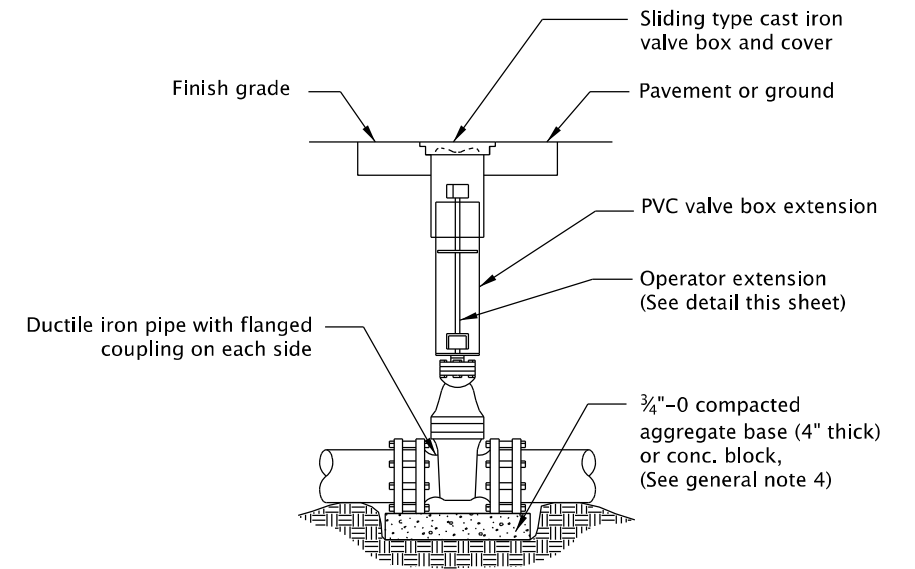

VALVE BOX  
ASSEMBLY DETAIL

\*\* Drawing Not to Scale \*\*

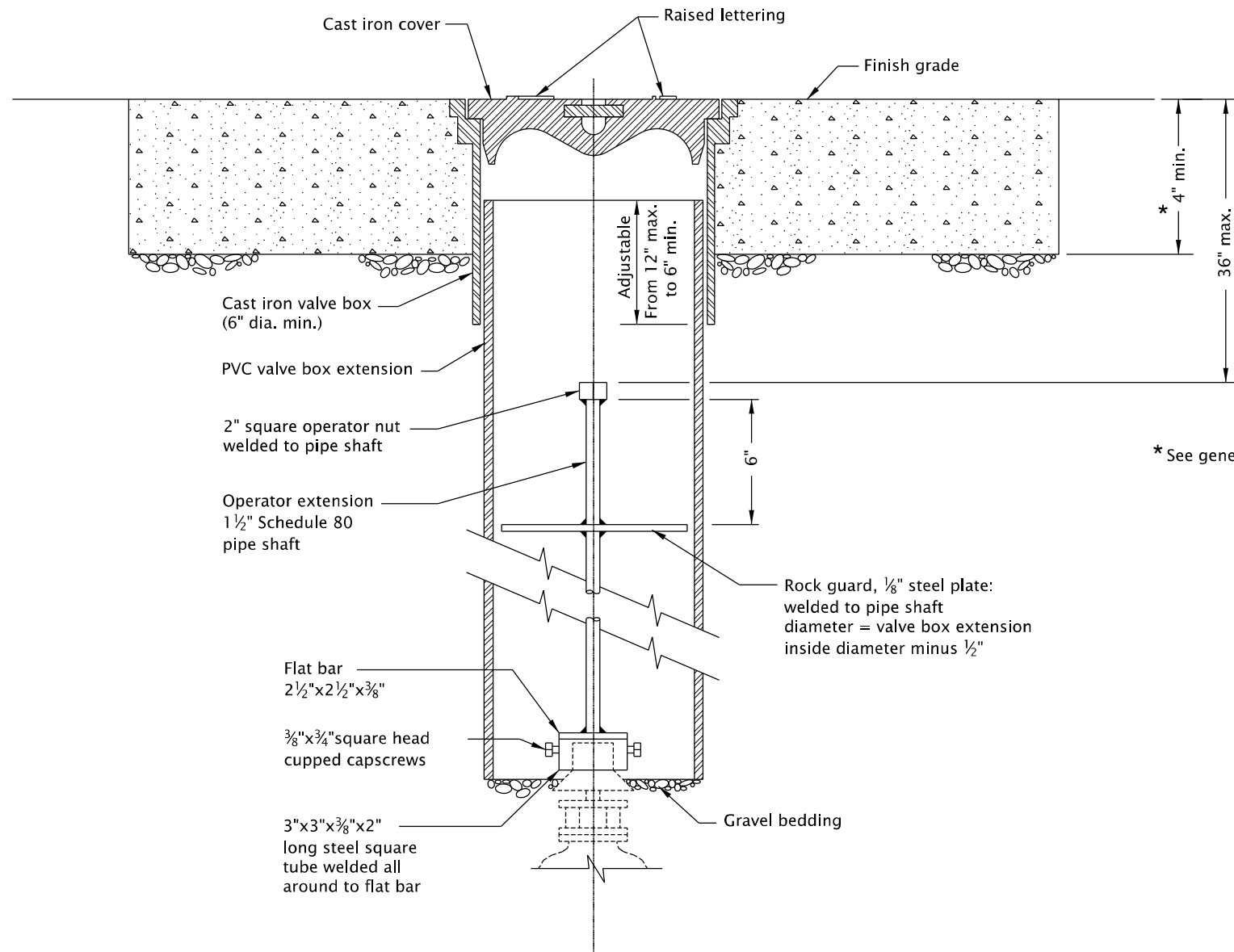

VALVE BOX EXTENSION SECTION

\* See general note 8

GENERAL NOTES FOR ALL DETAILS ON THIS SHEET:

1. Valve box not to rest on operating assembly.
2. Operator extension required when valve nut is deeper than 4' from finish grade.
3. Center valve box on axis of operator nut.
4. Valves 12" and smaller shall be provided with compacted aggr. base on undisturbed ground. Valves greater than 12" shall be installed on precast concrete block, (4" thick).
5. Welds shall be minimum 1/4" all around.
6. Hot dip galvanize operator extension after fabrication.
7. Casting shall meet H20 load requirement.
8. Provide concrete or asphalt pad (24" square, 4" thick), when required.
9. See project plans for details not shown.



RENEWS: 06-30-2024



OR213 (82ND AVE):  
SE FOSTER RD - SE THOMPSON RD SEC.  
CASCADE HIGHWAY NORTH  
CLACKAMAS & MULTNOMAH COUNTIES

Designer: Eric Webster      Reviewer: Kevin Thelin  
Drafter: Fouad Elgharabli      Checker: Tyler Nord

DETAILS

SHEET NO.  
HA08