

OPERATION & MAINTENANCE MANUAL

Water Quality Bioretention Pond

Manual prepared: **July 2022**

DFI No. **D01390**

Bioretention Pond DFI No. **D01390**

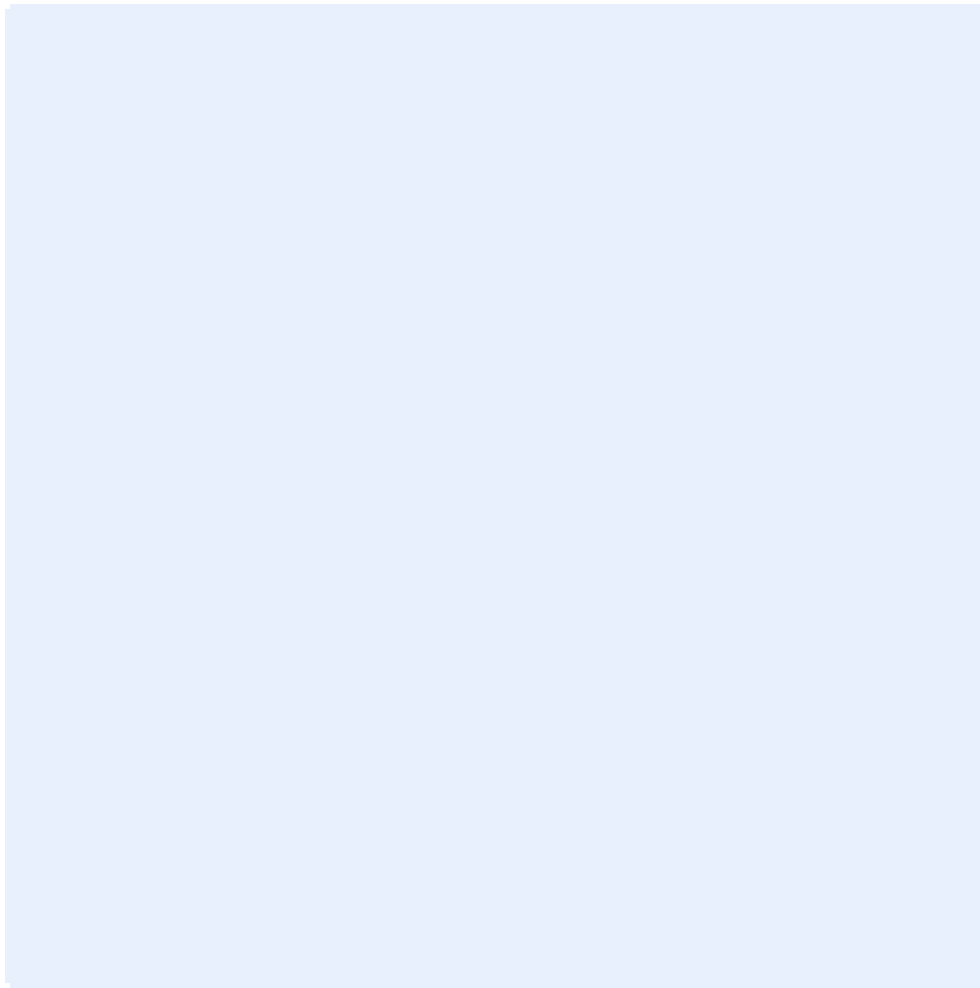

Figure 1: DFI No. D01390, looking **[note cardinal direction]**

1. Identification

Drainage Facility ID (DFI): D01390
Facility Type: Retention Pond
Construction Drawings: (V-File Numbers) 55V-086
Location: District: 10
Highway No.: 017
Mile Post: 14.71 to 14.72, [RT]

2. Manual Purpose

The purpose of this manual is to outline inspection needs and summarize maintenance actions for stormwater ponds.

3. Facility Location

The location map below details the facility location. The highway, mile posts, side streets, access location, and stormwater flow directions are noted on the map.

Facility location type: Roadway shoulder

Flow direction: [south]

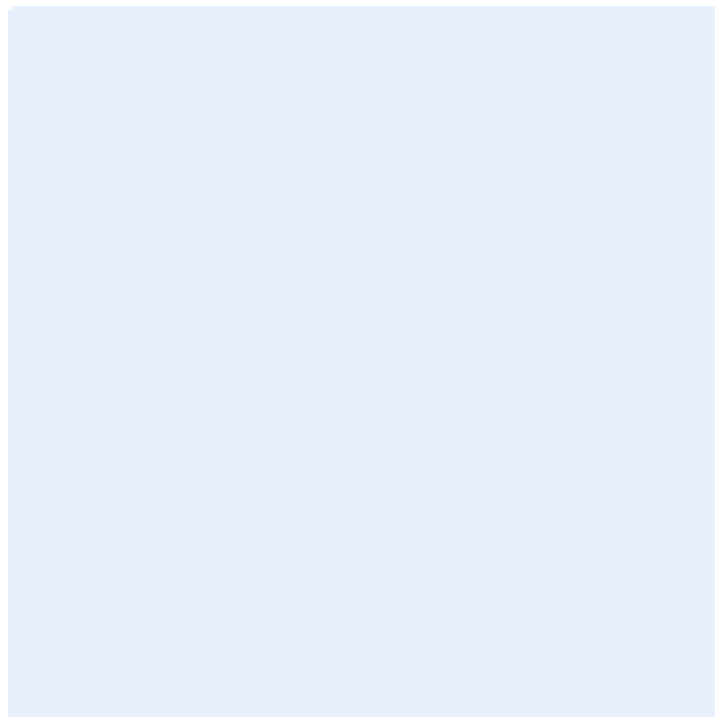

Figure 2: [ODOT Geo-Environmental to insert facility location map]

4. Facility Summary

The pond size is based on storage volume, the bottom and top surface areas and the depth are used for this measurement.

The bottom area and top area of the pond is:

Bottom Area (sq. ft.)	Top Area (sq. ft.)
1,570	4,274

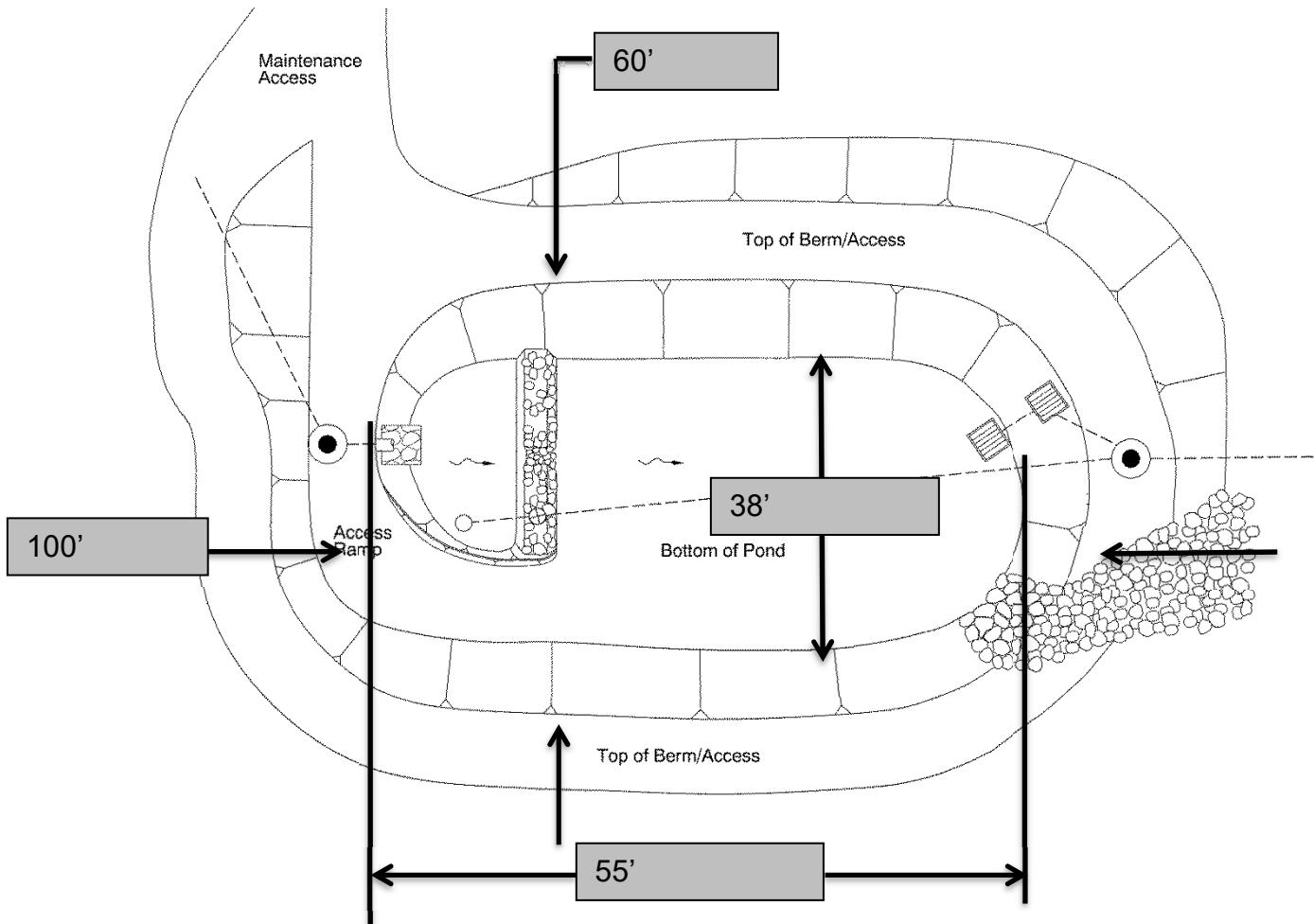

The depth of the pond is the vertical distance measured from the bottom of the pond to the top. The slope of the pond sides is presented by a vertical distance (rise) followed by the horizontal distance (run).

Depth and side slopes:

Depth (feet)
3.5

Side Slope	
Rise (feet)	1
Run (feet)	3

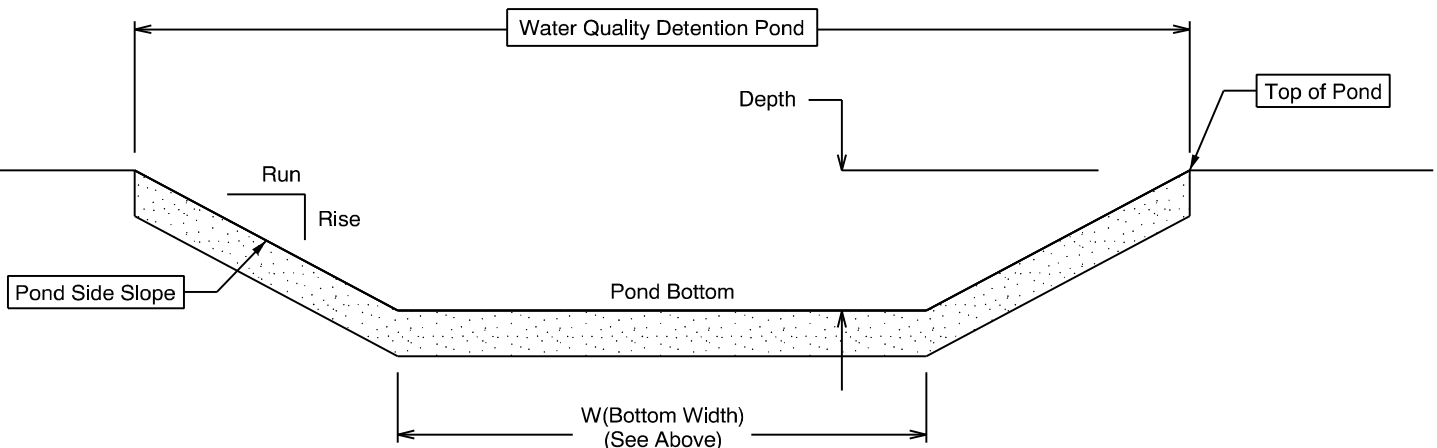

Site Specific Information: Existing irrigation pipe below access road has shallow cover. Use caution.

Infiltration into the subsurface is the only outlet for this facility.

5. Facility Access

Maintenance access to the facility:

<input type="checkbox"/> Roadside pad	<input type="checkbox"/> Roadside shoulder
<input type="checkbox"/> Access road with Gate	<input checked="" type="checkbox"/> Access road without Gate

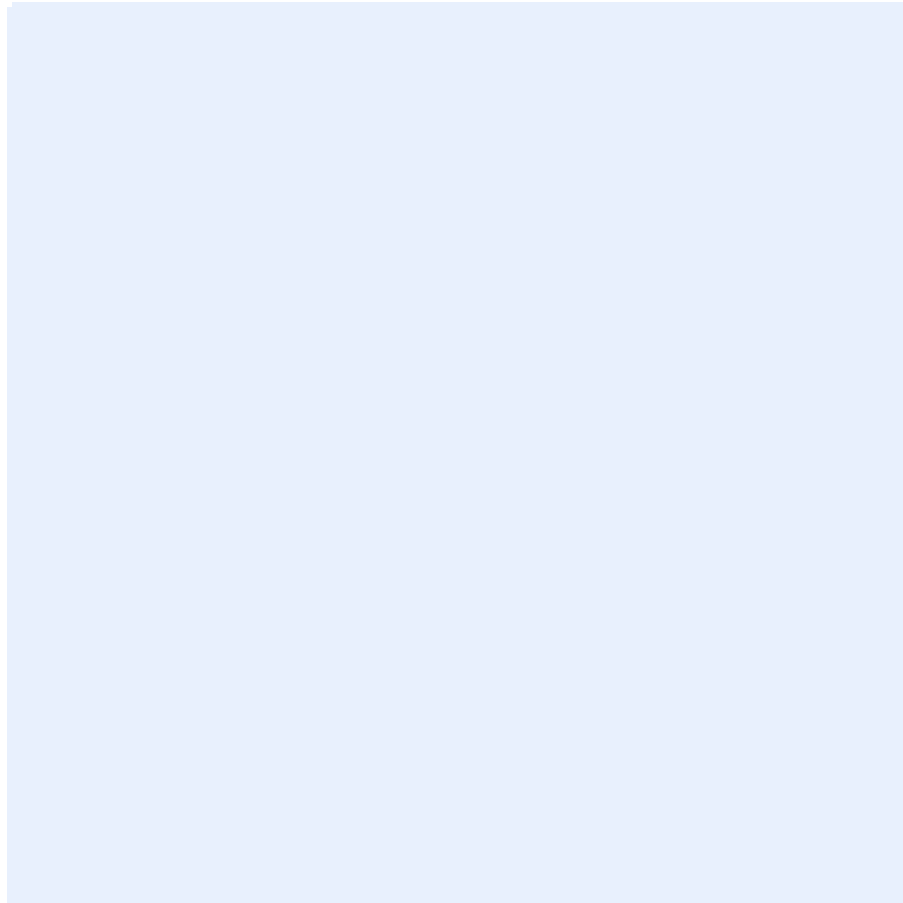

Figure 3: [insert post construction facility access photo and caption text]

6. Operational Components / Maintenance Items

Classification and Standard Operational (Op) Plan:

This facility is classified as a:

<input type="checkbox"/> Detention Pond (Op Plan A)	<input checked="" type="checkbox"/> WQ Bioretention Pond (Op Plan B)	<input type="checkbox"/> WQ Extended Detention Dry Pond (Op Plan C)	<input type="checkbox"/> WQ Detention Pond/Biofiltration Swale Combo (Op Plan D)
A standard operational plan illustrates the general facility footprint configuration and explains the purpose of each facility component. Operational plans (A,B,C,D) are provided in the Standard Operation Manual.			

See Appendix A for the site specific operational plan.

Key Features/Items:

This facility is classified as a:

<input checked="" type="checkbox"/> Dry Pond	<input type="checkbox"/> Wet Pond
The pond is wet during storm events and dries during periods of no precipitation.	The pond has constant presence of water year round. A portion of the pond dries during periods of no precipitation.

This facility includes a **high flow bypass component**:

<input checked="" type="checkbox"/> No	<input type="checkbox"/> Yes
There is no bypass component. High flows drain into and through the facility	There is a bypass component. Only low/small flows drain into the pond. High flows are diverted around the pond using a bypass component

This facility includes a **proprietary structure(s)**:

<input checked="" type="checkbox"/> No	<input type="checkbox"/> Yes
There are no proprietary structures associated with this facility.	A proprietary structure is used in the operation of this facility. The proprietary structure is a/an:

Operational Components

The facility components table (**Table 1**) has been provided to highlight the applicable components for this facility. The component is in use when the box contains an “x” (e.g.).

The Standard Operation Manual for Ponds (implemented **Month YYYY**) outlines facility operation, typical footprint configuration, and component definitions and details. A link to the manual is attached to the feature marker in TransGIS.

<https://gis.odot.state.or.us/TransGIS/>

Maintenance Items

Operational components marked in **Table 1** should be inspected and maintained according to Section 7. Each facility component is defined and detailed in the Standard Operation Manual using the associated ID number indicated in the table below.

Table 1: Stormwater Pond Components		ID #
Upstream Manholes/Structures		
Pre-treatment Manhole Type:	<input type="checkbox"/>	P1
Water Quality Manhole Type:	<input type="checkbox"/>	P2
Flow Splitter Manhole	<input type="checkbox"/>	P3
Standard Manhole	<input type="checkbox"/>	P4
Sediment Basin/Forebay	<input type="checkbox"/>	P5
Forebay Dewatering Riser Pipe (outlet)	<input type="checkbox"/>	P6
Facility Inlet		
Pavement Sheet Flow	<input type="checkbox"/>	P7
Inlet Pipe(s)	<input checked="" type="checkbox"/>	P8
Open Channel Inlet	<input type="checkbox"/>	P9
Riprap Pad (Energy Dissipater)	<input checked="" type="checkbox"/>	P10
Ground Cover		
Grass Bottom	<input type="checkbox"/>	P11
Grass Side Slopes	<input type="checkbox"/>	P12
Granular Drain Rock	<input type="checkbox"/>	P13
Plantings	<input type="checkbox"/>	P14
Underground Components		
Geotextile Fabric: Type 1	<input checked="" type="checkbox"/>	P15
Impermeable Liner	<input type="checkbox"/>	P16
Water Quality Mix	<input checked="" type="checkbox"/>	P17
Perforated Pipe	<input type="checkbox"/>	P18
Bottom Marker (ex. Porous Pavers)	<input checked="" type="checkbox"/>	P19

Flow Spreader		
Anchored Board (midpoint of pond or every 50 feet along pond bottom)	<input type="checkbox"/>	P20
Other:	<input type="checkbox"/>	P21
Facility Outlet		
Catch Basin with Grate	<input type="checkbox"/>	P22
Outlet Pipe(s)	<input type="checkbox"/>	P23
Outlet/Flow Control Structure	<input type="checkbox"/>	P24
Auxiliary Outlet	<input type="checkbox"/>	P25
Hazmat Control Valve:	<input type="checkbox"/>	P26
Outfall Type		
Waterbody (Creek/Lake/Ocean)	<input type="checkbox"/> C	P27
	<input type="checkbox"/> L	
	<input type="checkbox"/> O	
Ditch	<input type="checkbox"/>	P28
Storm Drain System	<input type="checkbox"/>	P29
Outfall Components		
Riprap Pad	<input type="checkbox"/>	P30
Riprap Bank Protection	<input type="checkbox"/>	P31

7. Maintenance

Maintenance Frequency/Maintain Records

- a. Inspect annually. Preferably prior to the rainy season.
- b. Clean and maintain as necessary. Refer to Activity 125 in the Maintenance Guide for conditions when maintenance is needed.
- c. Keep a record of inspections, maintenance, and repairs.

Maintenance Guide/Maintenance Actions

The Maintenance Guide outlines the standard maintenance actions for water quality facilities under Activity 125.

There are standard maintenance tables for standard ODOT designs. The maintenance tables describe the maintenance component, the defect or problem, the condition when maintenance is needed, and the recommended maintenance to correct the problem. Use the following tables to maintain ODOT Ponds:

- Table 1 (General Maintenance): Contains general maintenance and inspection guidelines that are applicable to all ODOT water quality facilities
- Table 2 (Maintenance of Stormwater Ponds): Contains maintenance information for ponds

The ODOT Maintenance Guide can be viewed at the following website:
<http://www.oregon.gov/ODOT/HWY/OOM/pages/mguide.aspx>

The Blue Book can be viewed at the following website:
http://www.oregon.gov/ODOT/Maintenance/Documents/blue_book.pdf

8. Limitations

There are access limitations for this facility:

<input type="checkbox"/> No	<input checked="" type="checkbox"/> Yes
Access pond via 16 foot gravel road from Wood Avenue near O.B. Riley Road. This road crosses over an existing, shallow irrigation main.	

Ponds are designed to allow equipment access along the bottom if an access grid is installed. If an access grid is NOT installed, vehicles entering the pond can create depressions (tire ruts), damage vegetation, or damage structural components (e.g. flow spreaders). These conditions may result in poor treatment and drainage performance.

If no access grid then: Equipment wheels should be kept on the tops and side slopes. Mower arms may be run along the pond bottom.

9. Waste Material Handling

Material removed from the facility is defined as waste by the Department of Environmental Quality (DEQ). Refer to the road waste section of the ODOT Maintenance Yard Environmental Management System (EMS) Policy and Procedures Manual for disposal options:

<http://www.oregon.gov/ODOT/HWY/OOM/pages/ems.aspx>

Contact any of the following for more detailed information about management of waste materials found on site:

ODOT Clean Water Unit	(503) 986-3008
ODOT Statewide Hazmat Coordinator	(503) 667-7442
ODOT Region 1 Hazmat Coordinator	(503) 731-8290
ODOT Region 2 Hazmat Coordinator	(503) 986-2647
ODOT Region 3 Hazmat Coordinator	(541) 957-3594
ODOT Region 4 Hazmat Coordinator	(541) 388-6186
ODOT Region 5 Hazmat Coordinator	(541) 963-1590
ODEQ Northwest Region Office	(503) 229-5263

A Appendix A – Site Specific Operational Plan

Contents:

Operational Plan: DFI D01390

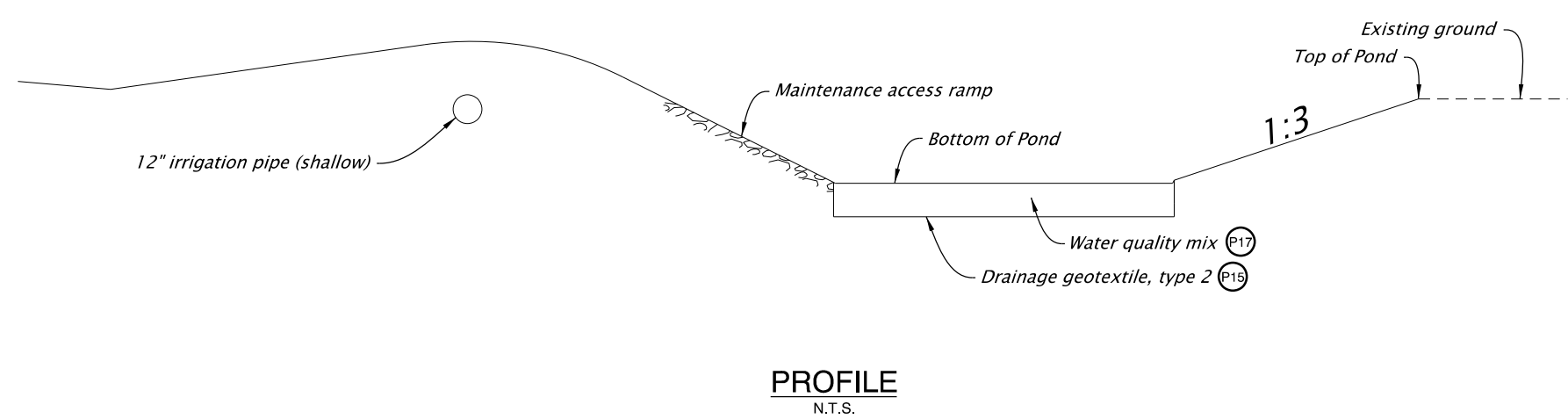
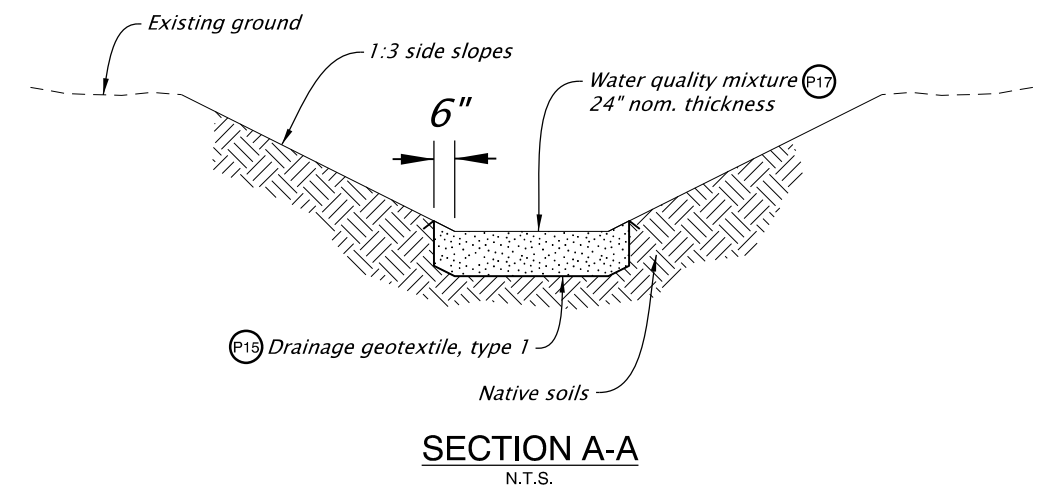
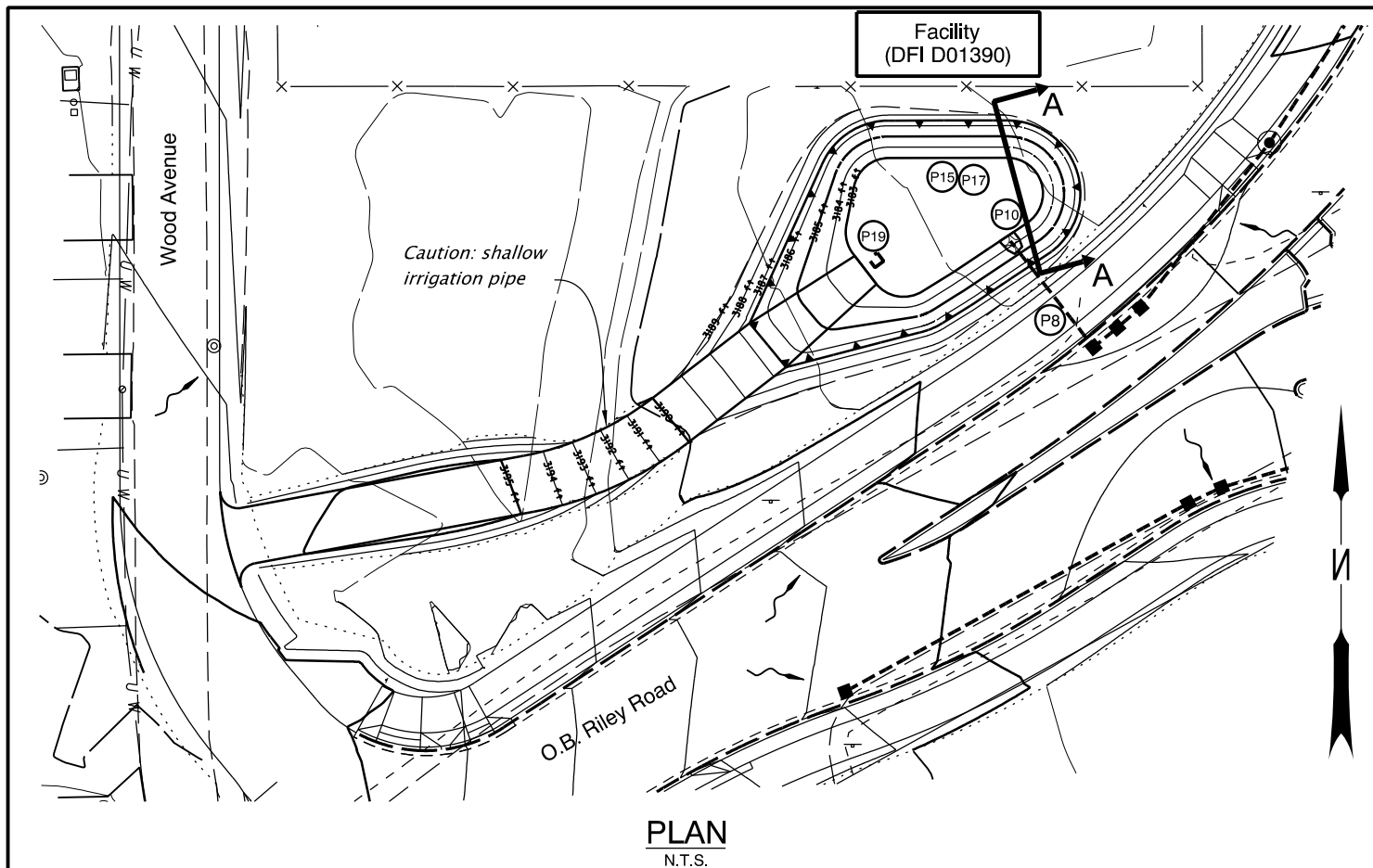

- LEGEND:
- Photo Location / Direction
 - Facility component (see table 1 in O&M Manual)
 - Manhole
 - Inlet
 - Manhole with Inlet Top
 - Storm Pipe (Facility)
 - Storm Pipe
 - Conveyance Direction
 - Pavement / Facility Flow Path

OREGON DEPARTMENT OF TRANSPORTATION

DFI D01390
MAINTENANCE DISTRICT 10 HWY 17
BIORETENTION POND
 14.40
 DESCHUTES COUNTY

Prepared By: Tyler Van Meter

Drafted By: Tyler Van Meter

B Appendix B – Project Contract Plans

Contents:

Drainage Plan Sheet

Stormwater Details

- ① Const. sloped end
- ② Const. riprap pad
(For details, see sht. HA02)
- ③ Inst. 12" storm sew. pipe - 32'
5' depth
- ④ Sta. "C" 54+34.14, 24.00' Lt.
Const. type G-2 inlet
Const. 24" sump
Const. gutter transition
Inst. 8" storm sew. pipe - 23'
5' depth
Inst. 8" storm sew. pipe - 45'
5' depth
(See dwg. nos RD388, RD390, RD393, RD364)
- ⑤ Sta. "C" 54+57.24, 24.00' Lt.
Const. type G-2 inlet
Const. 24" sump
Const. gutter transition
- ⑥ Sta. "C" 54+58.13, 16.83' Rt.
Const. type G-2 inlet
Const. 24" sump
Const. gutter transition
- ⑦ Const. sloped end
- ⑧ Const. riprap pad
(For details, see sht. HA02)
- ⑨ Inst. 12" storm sew. pipe - 55'
5' depth
- ⑩ Sta. "C" 53+36.37, 27.02' Lt.
Const. type G-2 inlet
Const. 24" sump
Const. gutter transition
Inst. 8" storm sew. pipe - 45'
5' depth
- ⑪ Sta. "C" 53+27.81, 19.27' Rt.
Const. type G-2 inlet
Const. 24" sump
Const. gutter transition
- ⑫ Const. bioretention pond D01389
(For details, see shts. HA01, HA02 and HA03)
- ⑬ Inst. field facility bottom marker, porous
pavers - 9 sq. ft.
- ⑭ Const. sloped end
- ⑮ Const. riprap pad
(For details, see sht. HA02)
- ⑯ Inst. 15" storm sew. pipe - 35'
10' depth
F.L. out = 3183.50
- ⑰ Sta. "OB" 48+09.79, 25.67' Lt.
Const. type G-2 inlet
Const. 24" sump
Const. gutter transition
Inst. 12" storm sew. pipe - 8'
10' depth
- ⑱ Sta. "OB" 48+17.63, 27.14' Lt.
Const. type G-2 inlet
Const. 24" sump
Const. gutter transition
Inst. 12" storm sew. pipe - 9'
5' depth
- ⑳ Sta. "OB" 48+26.20, 28.95' Lt.
Const. type G-2 inlet
Const. 24" sump
Const. gutter transition
Inst. 12" storm sew. pipe - 138'
10' depth
- ㉑ Sta. "L" 108+83.84, 68.04' Rt.
Const. type G-2 inlet
Const. 24" sump
Const. gutter transition
Inst. 12" storm sew. pipe - 164'
10' depth
- ㉒ Sta. "L" 106+99.24, 35.00' Rt.
Const. type G-2 inlet
Const. 24" sump
Const. gutter transition
Inst. 12" storm sew. pipe - 281'
10' depth
- ㉓ Sta. "L" 103+79.76, 40.60' Rt.
Const. type G-2 inlet
Const. 24" sump
Const. gutter transition
Inst. 12" storm sew. pipe - 48'
5' depth
- ㉔ Sta. "L" 103+31.98, 39.00' Rt.
Const. type G-2 inlet
Const. 24" sump
Const. gutter transition
Inst. 12" storm sew. pipe - 42'
5' depth
- ㉕ Sta. "L" 102+90.09, 39.00' Rt.
Const. type G-2 inlet
Const. 24" sump
Const. gutter transition
- ㉖ Const. bioretention pond D01390
(For details, see shts. HA01, HA02 and HA03)
- ㉗ Const. access road
(For details, see sht. HA02)
- ㉘ Inst. field facility bottom marker, porous
pavers - 9 sq. ft.
- ㉙ Protect existing shallow irrigation pipe.
- ㉚ Inst. stormwater field marker, type S1, red
DFI D01390
MP 14.70
- ㉛ Inst. stormwater field marker, type S2
DFI D01390
MP 14.69
- ㉜ Const. riprap pad
(For details, see sht. HA02 and RD317)
- ㉝ Const. sloped end
- ㉞ Inst. 18" storm sew. pipe - 73'
10' depth
- ㉟ Sta. "L" 112+06.47, 33.13' Rt.
Const. manhole 60" with inlet, type G-2
Const. 24" sump
Const. gutter transition
Inst. 15" storm sew. pipe - 169'
10' depth
Inst. 15" storm sew. pipe - 68'
10' depth
(See dwg. nos RD335, RD336)
- ㊱ Sta. "L" 111+90.48, 35.00' Lt.
Const. type G-2 inlet
Const. 24" sump
Const. gutter transition
Inst. 15" storm sew. pipe - 115'
10' depth
- ㊲ Sta. "L" 110+57.07, 56.65' Lt.
Const. type G-2 inlet
Const. 24" sump
Const. gutter transition
Inst. 15" storm sew. pipe - 117'
10' depth
- ㊳ Sta. "L" 109+63.11, 125.38' Lt.
Const. manhole 48" dia.
Inst. 15" storm sew. pipe - 110'
10' depth
Inst. 12" storm sew. pipe - 26'
5' depth
- ㊴ Sta. "C" 51+27.42, 31.97' Rt.
Const. type G-2 inlet
Const. 24" sump
Const. gutter transition
Inst. 12" storm sew. pipe - 54'
5' depth
- ㊵ Sta. "C" 51+65.06, 44.08' Rt.
Const. type G-2 inlet
Const. 24" sump
Const. gutter transition
- ㊶ Sta. "L" 108+61.48, 83.52' Lt.
Const. manhole 48" dia.
Inst. 15" storm sew. pipe - 59'
10' depth
Inst. 15" storm sew. pipe - 58'
5' depth
- ㊷ Sta. "C" 51+99.63, 40.32' Lt.
Const. type G-2 inlet
Const. 24" sump
Const. gutter transition
- ㊸ Sta. "L" 108+22.25, 44.61' Lt.
Const. type G-2 inlet
Const. 24" sump
Const. gutter transition
Inst. 15" storm sew. pipe - 354'
5' depth
- ㊹ Sta. "L" 104+78.05, 33.41' Lt.
Const. manhole 60" dia.
Inst. 12" storm sew. pipe - 85'
5' depth
Inst. 12" storm sew. pipe - 26'
5' depth
Inst. 12" storm sew. pipe - 42'
5' depth
- ㊺ Sta. "L" 105+04.85, 66.89' Lt.
Const. type G-2 inlet
Const. 24" sump
Const. gutter transition
- ㊻ Sta. "L" 104+54.78, 46.87' Lt.
Const. type G-2 inlet
Const. 24" sump
Const. gutter transition
- ㊼ Sta. "L" 103+92.98, 39.00' Lt.
Const. type G-2 inlet
Const. 24" sump
Const. gutter transition
Inst. 12" storm sew. pipe - 97'
5' depth
- ㊽ Sta. "L" 102+95.77, 39.00' Lt.
Const. type G-2 inlet
Const. 24" sump
Const. gutter transition
Inst. 12" storm sew. pipe - 102'
5' depth
- ㊾ Sta. "L" 101+93.96, 39.00' Lt.
Const. type G-2 inlet
Const. 24" sump
Const. gutter transition
- ㊿ Sta. "L" 110+63.77, 68.77' Rt.
Const. manhole 48" dia.
Inst. 12" storm sew. pipe - 68'
5' depth
- ① Sta. "OB" 48+46.16, 37.95' Rt.
Const. type G-2 inlet
Const. 24" sump
Const. gutter transition
Inst. 12" storm sew. pipe - 25'
5' depth
- ② Sta. "OB" 48+22.41, 32.54' Rt.
Const. type G-2 inlet
Const. 24" sump
Const. gutter transition
Inst. 12" storm sew. pipe - 10'
5' depth
- ③ Sta. "OB" 48+12.37, 31.94' Rt.
Const. type G-2 inlet
Const. 24" sump
Const. gutter transition
Inst. 12" storm sew. pipe - 110'
5' depth
- ④ Sta. "OB" 47+02.08, 31.70' Rt.
Const. type G-2 inlet
Const. 24" sump
Const. gutter transition
- ⑤ Const. sloped end
- ⑥ Const. riprap pad
(For details, see sht. HA02)
- ⑦ Inst. 12" storm sew. pipe - 47'
10' depth
F.L. out = 3182.50
- ⑧ Sta. "L" 113+22.64, 30.00' Rt.
Const. type G-2 inlet
Const. gutter transition
Inst. 12" storm sew. pipe - 63'
5' depth
Inst. 12" storm sew. pipe - 106'
5' depth
- ⑨ Sta. "L" 113+38.52, 33.12' Lt.
Const. type G-2 inlet
Const. 24" sump
Const. gutter transition
Inst. 12" storm sew. pipe - 94'
5' depth
- ⑩ Sta. "L" 114+29.67, 30.00' Lt.
Const. type G-2 inlet
Const. 24" sump
Const. gutter transition
Inst. 12" storm sew. pipe - 47'
5' depth
- ⑪ Sta. "L" 114+76.44, 30.00' Lt.
Const. type G-2 inlet
Const. 24" sump
Const. gutter transition
- ⑫ Sta. "L" 114+31.24, 30.00' Rt.
Const. type G-2 inlet
Const. 24" sump
Const. gutter transition
Inst. 12" storm sew. pipe - 45'
5' depth
- ⑬ Sta. "L" 114+76.44, 30.00' Rt.
Const. type G-2 inlet
Const. 24" sump
Const. gutter transition
- ⑭ Const. bioretention pond D01392
(For details, see shts. HA01, HA02 and HA04)
- ⑮ Const. riprap slope protection
(Class 50) - 25 cu. yd.
(For detail, see sht. HA02)
- ⑯ Const. access road
(For details, see sht. HA02)
- ⑰ Inst. field facility bottom marker, porous
pavers - 9 sq. ft.
- ⑱ Const. drainage berm - 261'
18" height
For detail, see sht. HA01
- ⑳ Inst. stormwater field marker, type S1, red
DFI D01392
MP 14.76
- ㉑ Inst. stormwater field marker, type S1, green
DFI D01392
MP 14.83
- ㉒ Inst. stormwater field marker, type S2
DFI D01392
MP 14.77
- ㉓ Inst. stormwater field marker, type S2
DFI D01392
MP 14.83
- ㉔ Sta. "L" 104+28.45, 34.44' Rt.
Const. manhole 48" dia.
Inst. 12" storm sew. pipe - 40'
5' depth
Inst. 12" storm sew. pipe - 63'
5' depth
- ㉕ Sta. "L" 104+04.91, 95.20' Rt.
Const. type G-2 inlet

General Notes:
 1. See profiles on sheets C02F and C02H for pipe invert elevations and slopes.
 2. Station/Offset call-outs for Type "G-2" and "CG-3" inlets are to the face of curb. Station/Offset call-outs for manholes are to the center of structure.

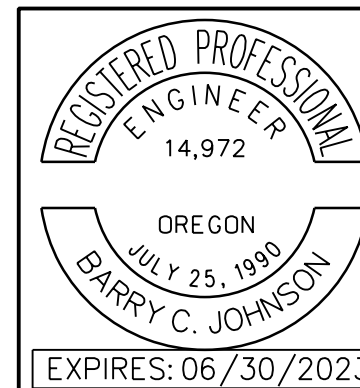

Parametrix <small>ENGINEERING · PLANNING · ENVIRONMENTAL SCIENCES</small> <hr style="border: 2px solid black;"/> <small>700 NE MULTNOMAH, SUITE 1000 PORTLAND, OR 97232 P 503.233.2400 WWW.PARAMETRIX.COM</small>		
US20: TUMALO - COOLEY RD. (BEND) SEC. MCKENZIE-BEND HIGHWAY DESCHUTES COUNTY		
Designer: Tyler Van Meter Drafter: Tyler Van Meter	Reviewer: Barry Johnson Checker: Shawn Ellis	
DRAINAGE NOTES		SHEET NO. C02C

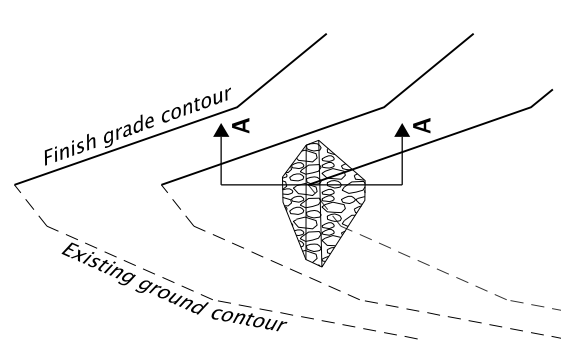

PLAN

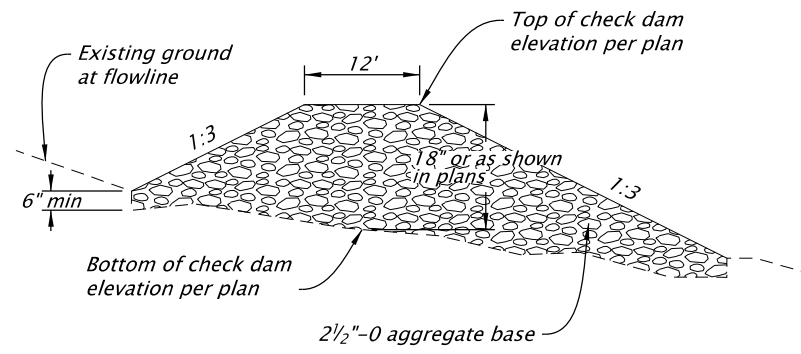

SECTION A-A

CHECK DAM LOCATION TABLE				
Location		Elevation		Quantity (cu. yd.)
Station	Offset	Top	Flowline	
"L" 90+29.1	29' Rt	3215.5	3215.0	1.0
"L" 90+65.2	29' Rt	3214.5	3214.0	1.0
"L" 90+96.8	32' Rt	3213.5	3213.0	1.0
"L" 91+20.3	38' Rt	3212.5	3211.0	3.0
"L" 91+44.4	40' Rt	3211.5	3210.5	1.5

CHECK DAMS

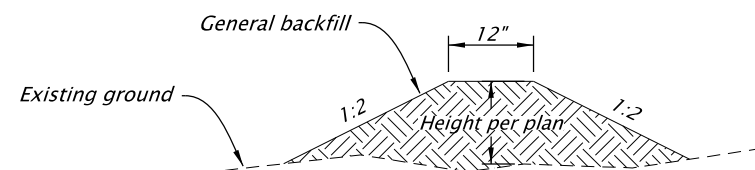

DRAINAGE BERM AT TOP OF POND

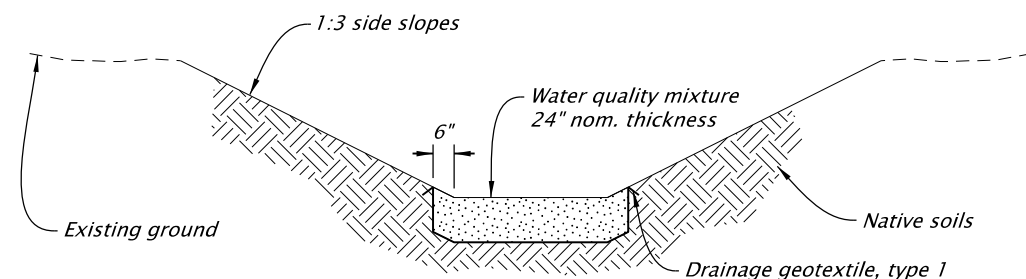

BIORETENTION POND TYPICAL SECTION

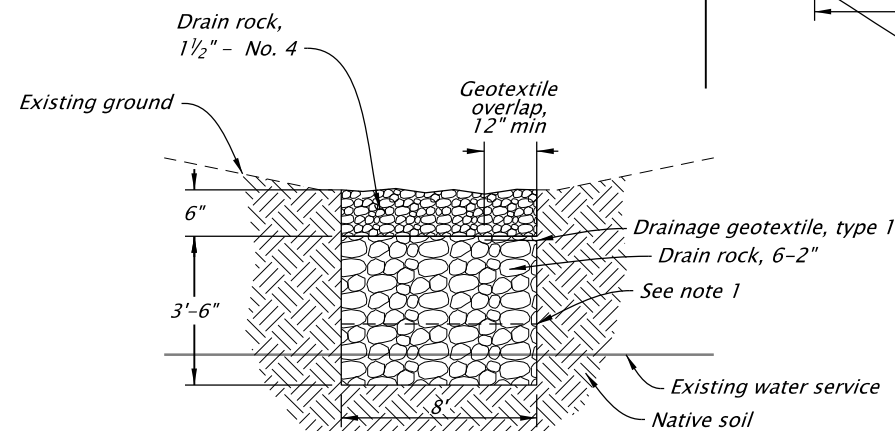

Note:

Adjust bottom of trench to maintain 2' clear horizontally and 6" clear vertically from water service pipe. Pothole to verify water pipe location.

Adjust horizontal layout of trench to maintain 1' clear from existing water meter vault and existing irrigation pipe.

INFILTRATION TRENCH

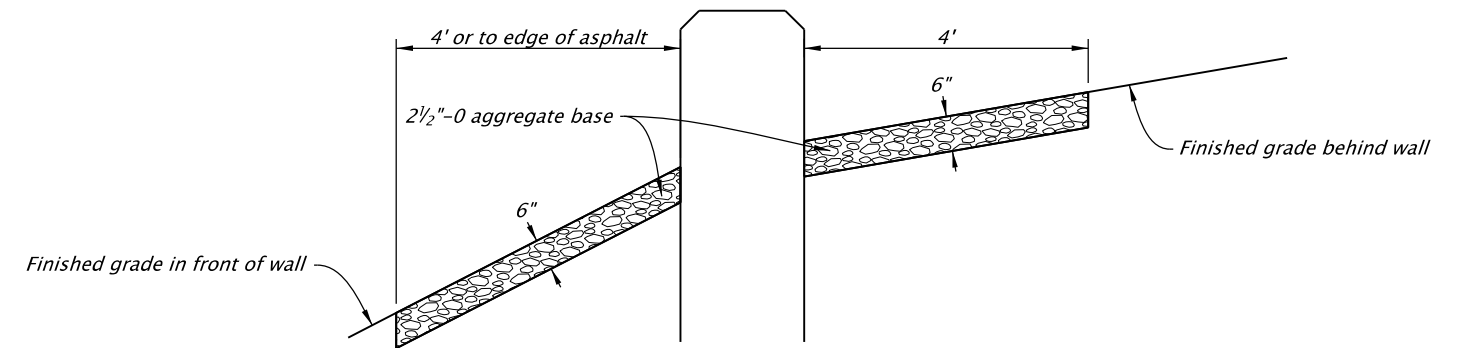

SLOPE PROTECTION AT CULVERT WINGWALLS

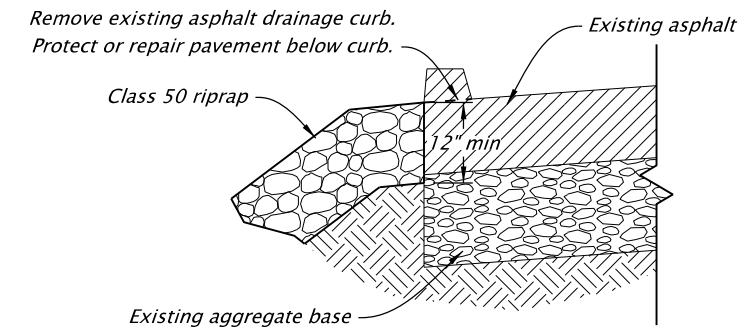

SECTION B-B

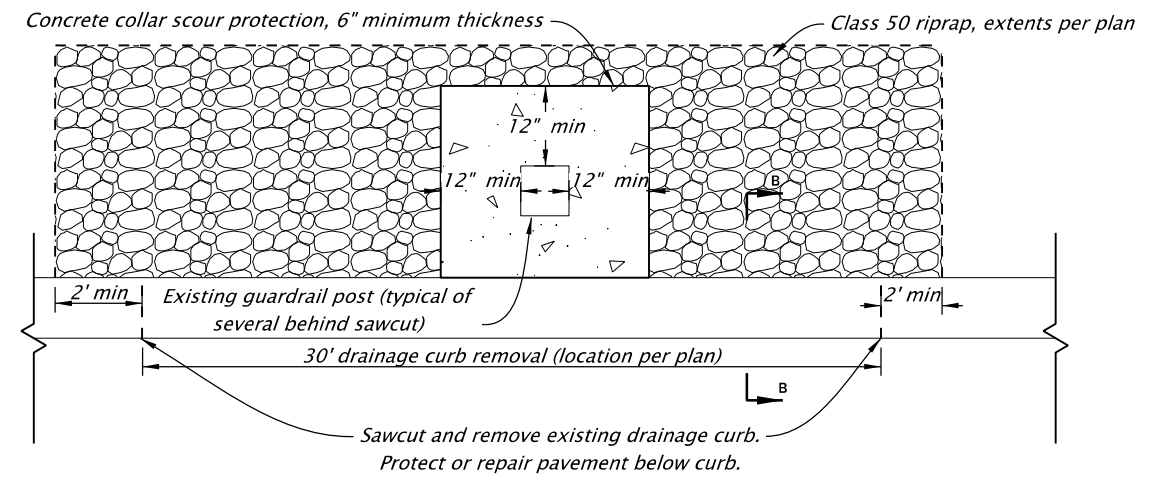

PLAN

CURB CUT AT HWY US20 / 5TH ST

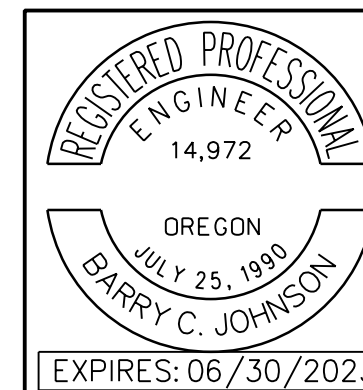

Parametrix
ENGINEERING · PLANNING · ENVIRONMENTAL SCIENCES
700 NE MULTNOMAH, SUITE 1000 | PORTLAND, OR 97232
P 503.233.2400
WWW.PARAMETRIX.COM



US20: TUMALO - COOLEY RD. (BEND) SEC.
MCKENZIE-BEND HIGHWAY
DESCHUTES COUNTY

Designer: Tyler Van Meter
Drafter: Tyler Van Meter

Reviewer: Barry Johnson
Checker: Shawn Ellis

STORMWATER DETAILS

SHEET NO.
HA01

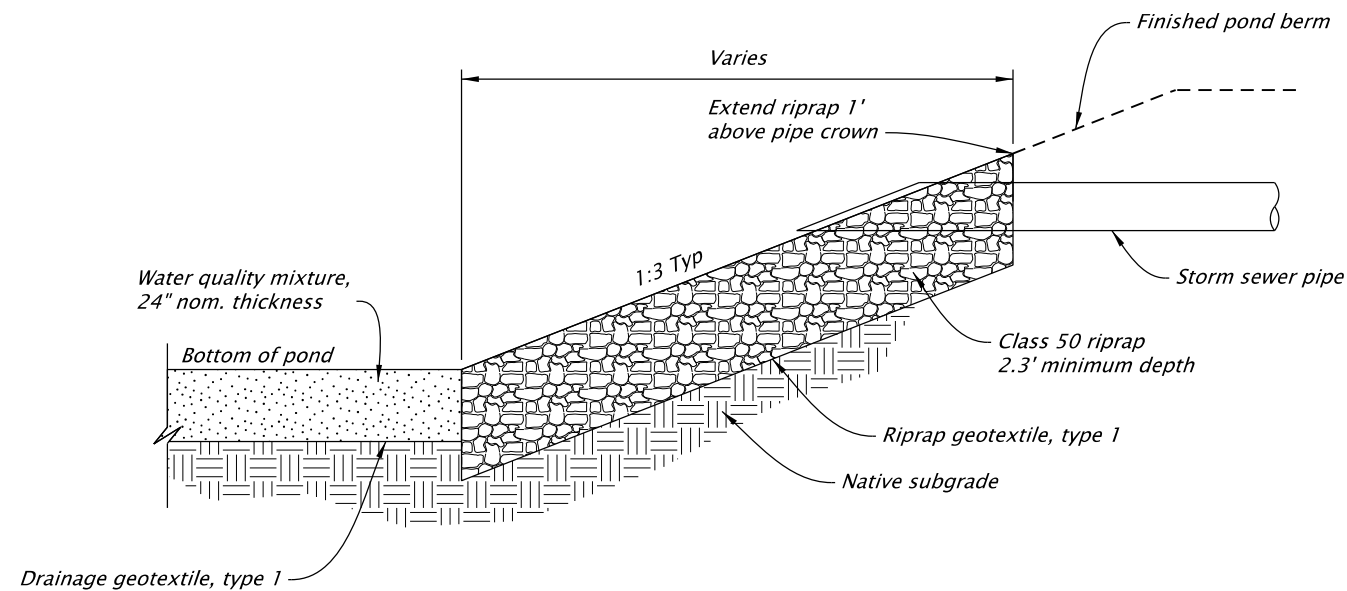

- Notes:
 1. Riprap pad to be centered on pipe outfall
 2. See ODOT std. dwg. RD317

POND ENERGY DISSIPATOR

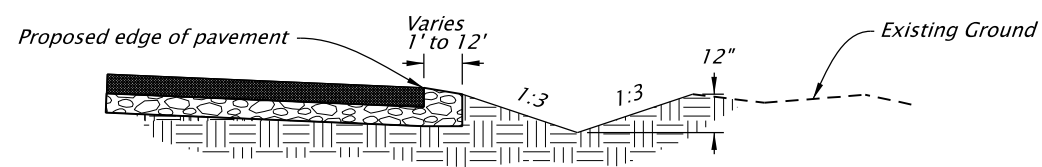

BAILEY RD

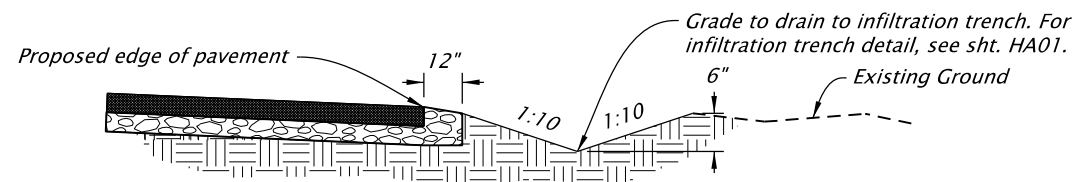

WOOD AVE

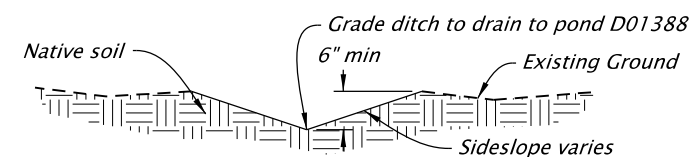

NORTH POND

V-DITCH

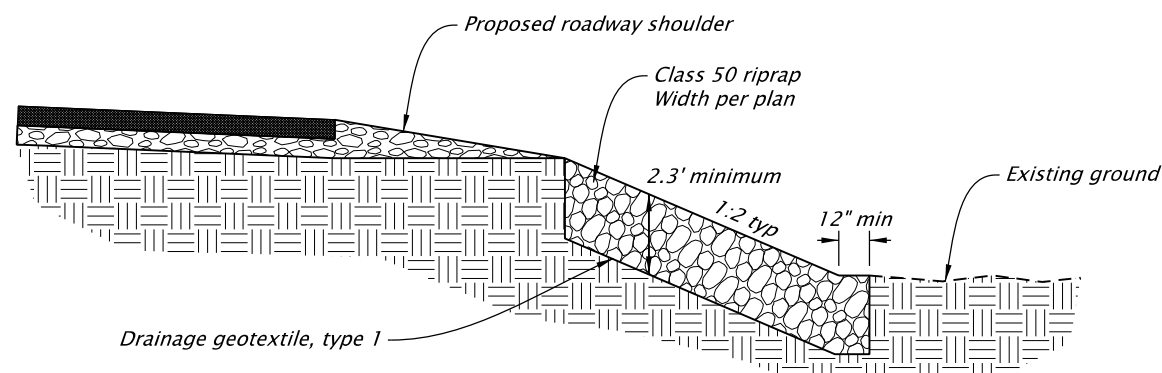

LOOSE RIPRAP SLOPE PROTECTION

FACILITY ID MARKER TABLE							
Facility Location	Station	MP	DFI Number	Type S2 Marker		Type S1 Marker	
				Begin	End	Red	Green
"L" 95+49 Rt.	14.45		D01388	✓		✓	
"L" 92+90 Rt.	14.40		D01388		✓		✓
"L" 95+05 Rt.	14.44		D01388	✓			
"L" 93+57 Rt.	14.41		D01388		✓		
"C" 53+51 Lt.	14.68		D01389	✓		✓	
"C" 54+35 Lt.	14.66		D01389		✓		✓
"C" 53+50 Lt.	14.67		D01389	✓			
"C" 54+37 Lt.	14.68		D01389		✓		
"OB" 48+42 Lt.	14.70		D01390	✓		✓	
"OB" 45+97 Lt.	14.71		D01390		✓		✓
"OB" 47+78 Lt.	14.69		D01390	✓			
"L" 112+21 Rt.	14.76		D01392	✓		✓	
"L" 115+86 Rt.	14.83		D01392		✓		✓
"L" 112+44 Rt.	14.77		D01392	✓			
"L" 115+74 Rt.	14.83		D01392		✓		

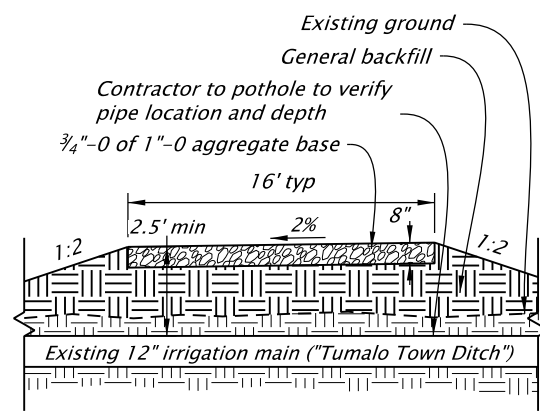

TUMALO TOWN DITCH OVERCROSSING

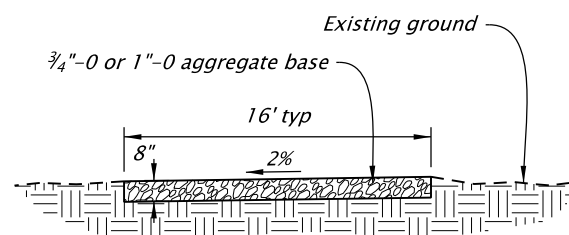

TYPICAL ACCESS ROAD

POND MAINTENANCE ACCESS ROAD

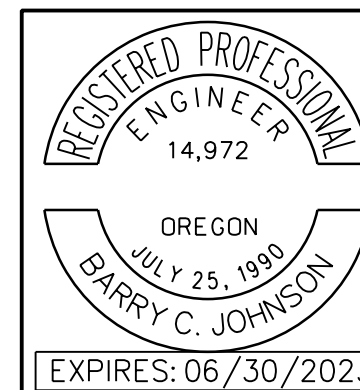

Parametrix
 ENGINEERING · PLANNING · ENVIRONMENTAL SCIENCES
 700 NE MULTNOMAH, SUITE 1000 | PORTLAND, OR 97232
 P 503.233.2400
 WWW.PARAMETRIX.COM



US20: TUMALO - COOLEY RD. (BEND) SEC.
 MCKENZIE-BEND HIGHWAY
 DESCHUTES COUNTY

Designer: Tyler Van Meter Reviewer: Barry Johnson
 Drafter: Tyler Van Meter Checker: Shawn Ellis

STORMWATER DETAILS

SHEET NO.
 HA02

D01390
 Bottom of pond
 Area: 174 sq yd
 Elevation: 3183.00
 Top of storage
 Area: 393 sq yd
 Elevation: 3185.50
 Top of pond
 Elevation: 3186.50
 Area: 475 sq yd

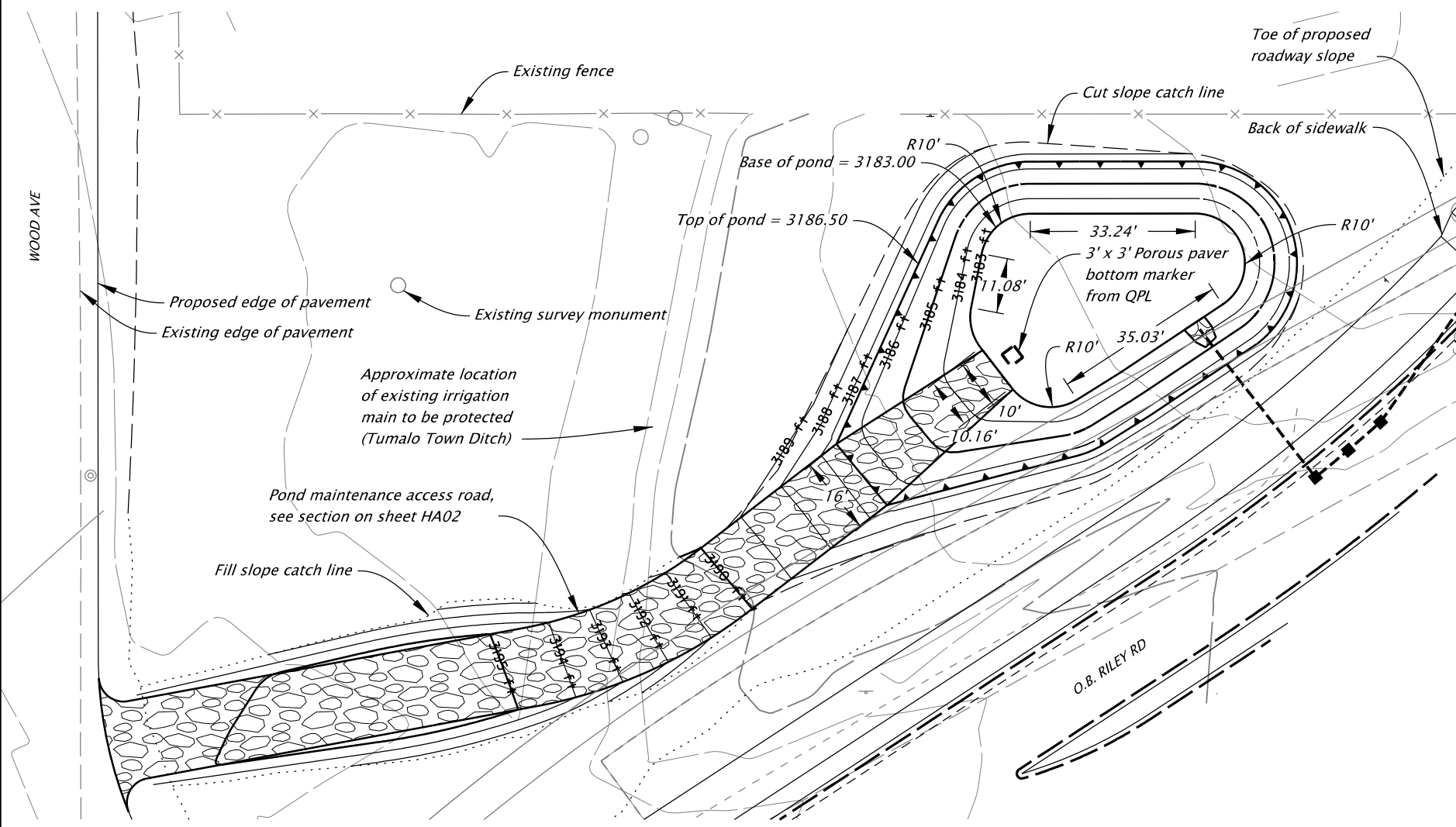

D01390 BIORETENTION POND

D01389
 Bottom of pond
 Area: 16 sq yd
 Elevation: 3180.00
 Top of storage (100-yr event)
 Area: 161 sq yd
 Elevation: 3183.50
 Top of pond
 Elevation: 3184.50
 Area: 219 sq yd

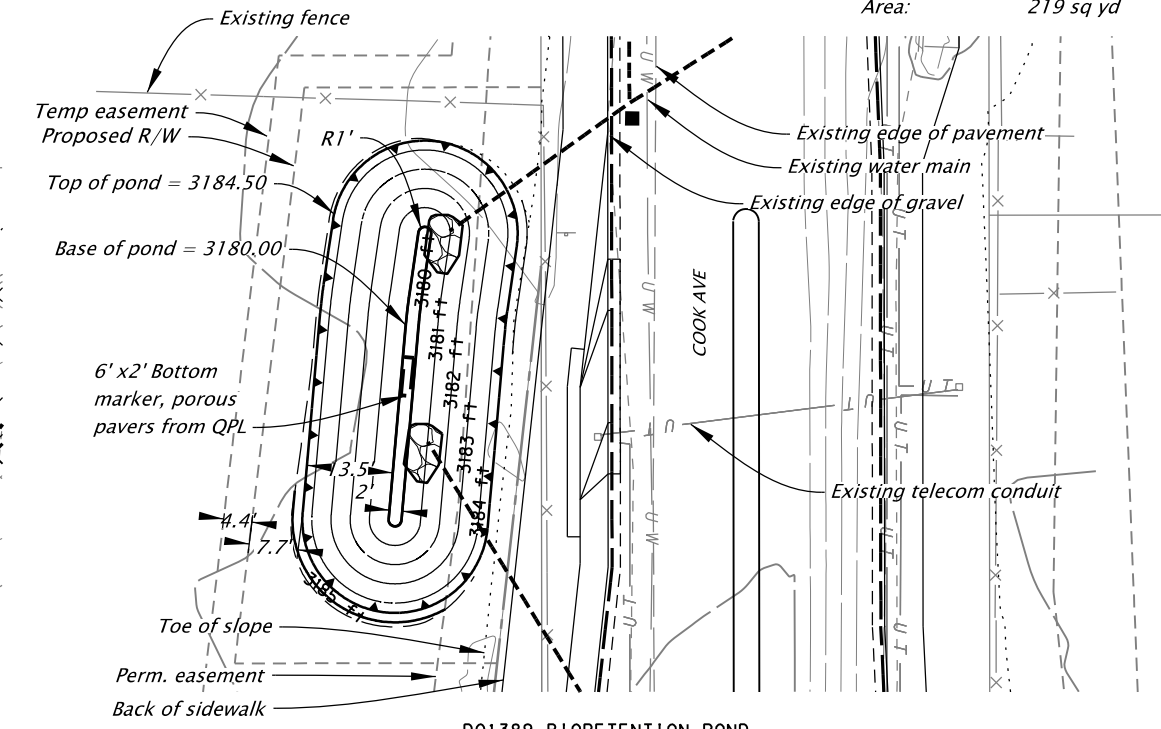

D01389 BIORETENTION POND

REGISTERED PROFESSIONAL
 ENGINEER
 14,972
 OREGON
 JULY 25, 1990
 BARRY C. JOHNSON
 EXPIRES: 06/30/2023

Parametrix
 ENGINEERING · PLANNING · ENVIRONMENTAL SCIENCES
 700 NE MULTNOMAH, SUITE 1000 | PORTLAND, OR 97232
 P 503.233.2400
 WWW.PARAMETRIX.COM

US20: TUMALO - COOLEY RD. (BEND) SEC.
 MCKENZIE-BEND HIGHWAY
 DESCHUTES COUNTY

Designer: Tyler Van Meter Reviewer: Barry Johnson
 Drafter: Tyler Van Meter Checker: Shawn Ellis

STORMWATER DETAILS SHEET NO. HA03