

OPERATION & MAINTENANCE MANUAL

Water Quality Bioretention Pond

Manual prepared: 7/2021

DFI No. D01341

1. Identification

Drainage Facility ID (DFI): D01341
Facility Type: Water Quality Bioretention Pond
Construction Drawings: 54V-063
Location: District: 10
Highway No.: 007
Mile Post: 3.49 to 3.505, [R]

2. Manual Purpose

The purpose of this manual is to outline inspection needs and summarize maintenance actions for stormwater ponds.

3. Facility Location

The location map below details the facility location. The highway, mile posts, side streets, access location, and stormwater flow directions are noted on the map.

Facility location type: Access Road

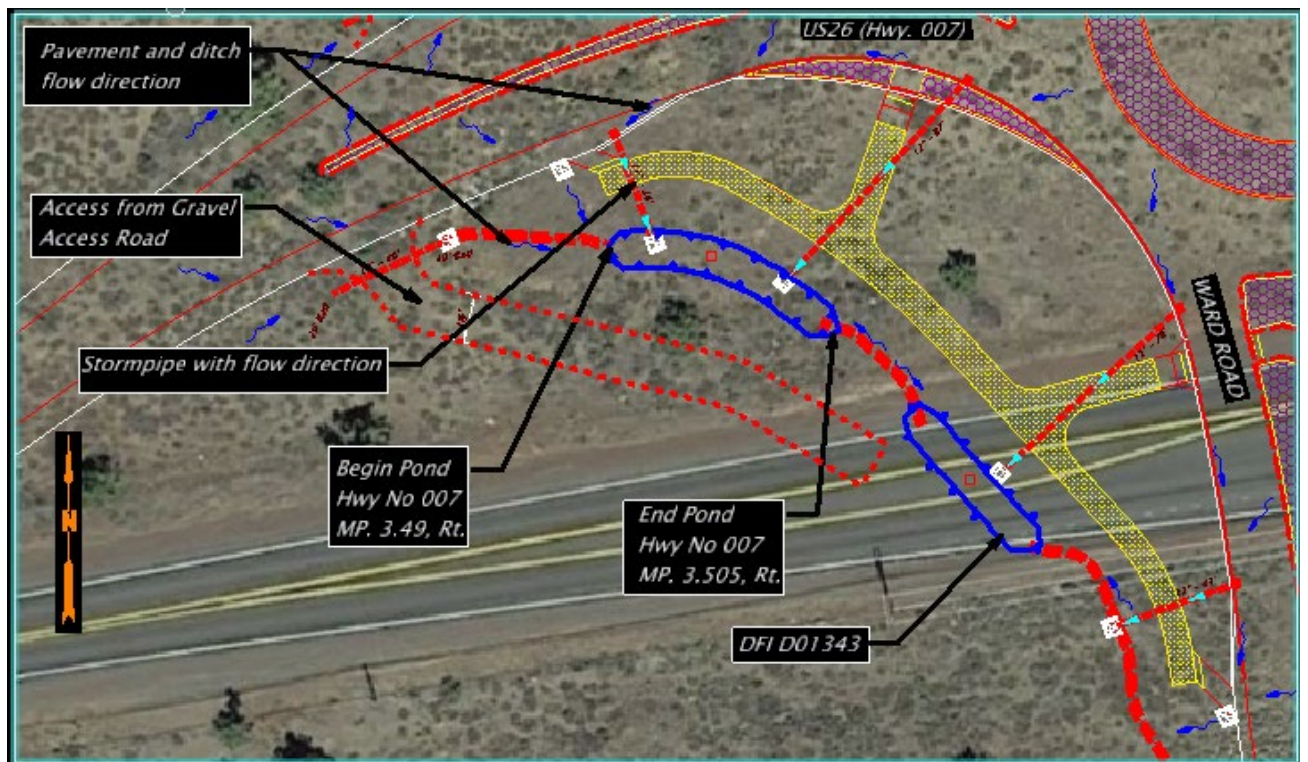

Figure 1: [ODOT Geo-Environmental to insert facility location map]

4. Facility Summary

The pond size is based on storage volume, the bottom and top surface areas and the depth are used for this measurement.

The bottom area and top area of the pond is:

Bottom Area (sq. ft.)	Top Area (sq. ft.)
225	1600

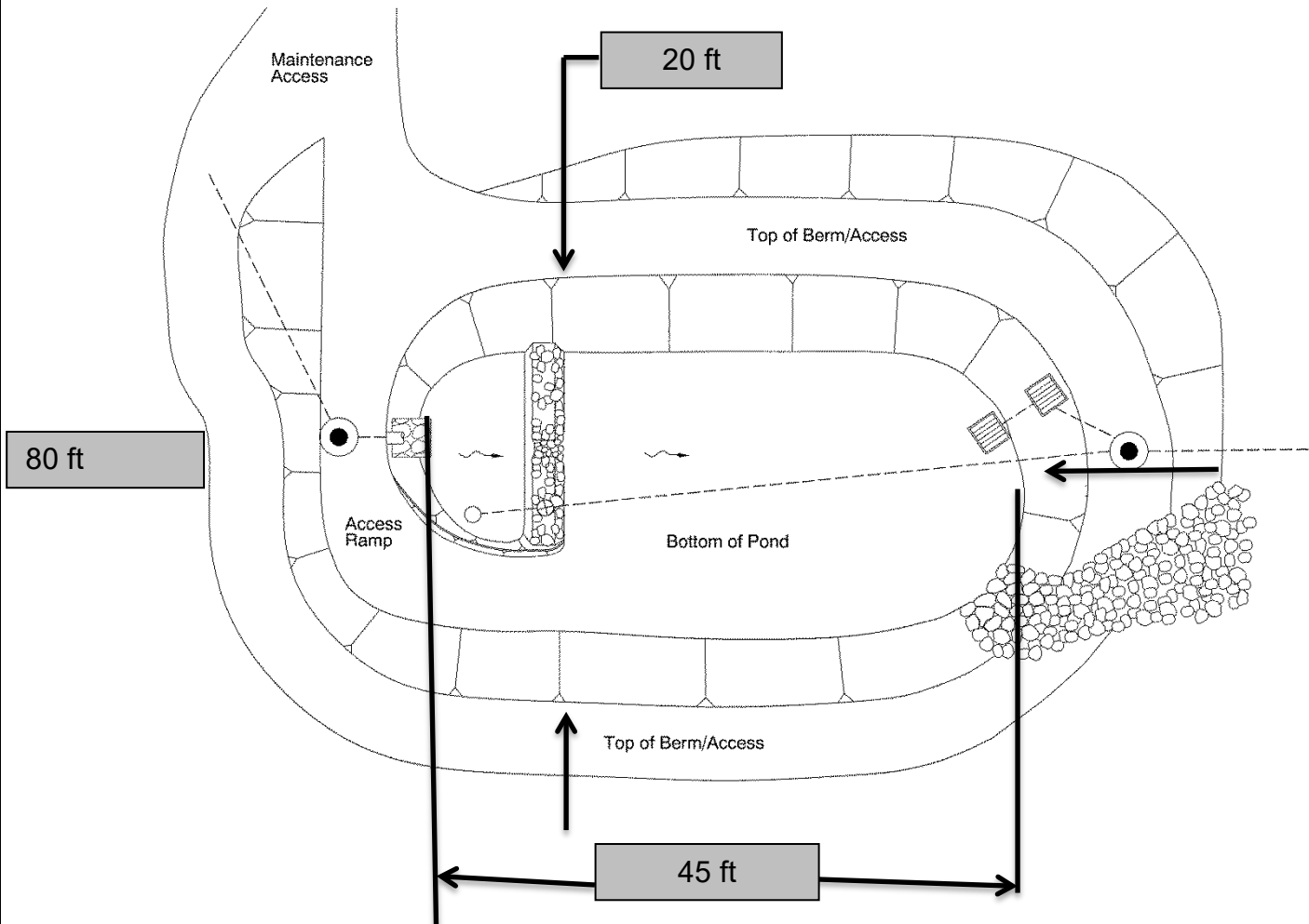

The depth of the pond is the vertical distance measured from the bottom of the pond to the top. The slope of the pond sides is presented by a vertical distance (rise) followed by the horizontal distance (run).

Depth and side slopes:

Depth (feet)
2

Side Slope	
Rise (feet)	1
Run (feet)	3

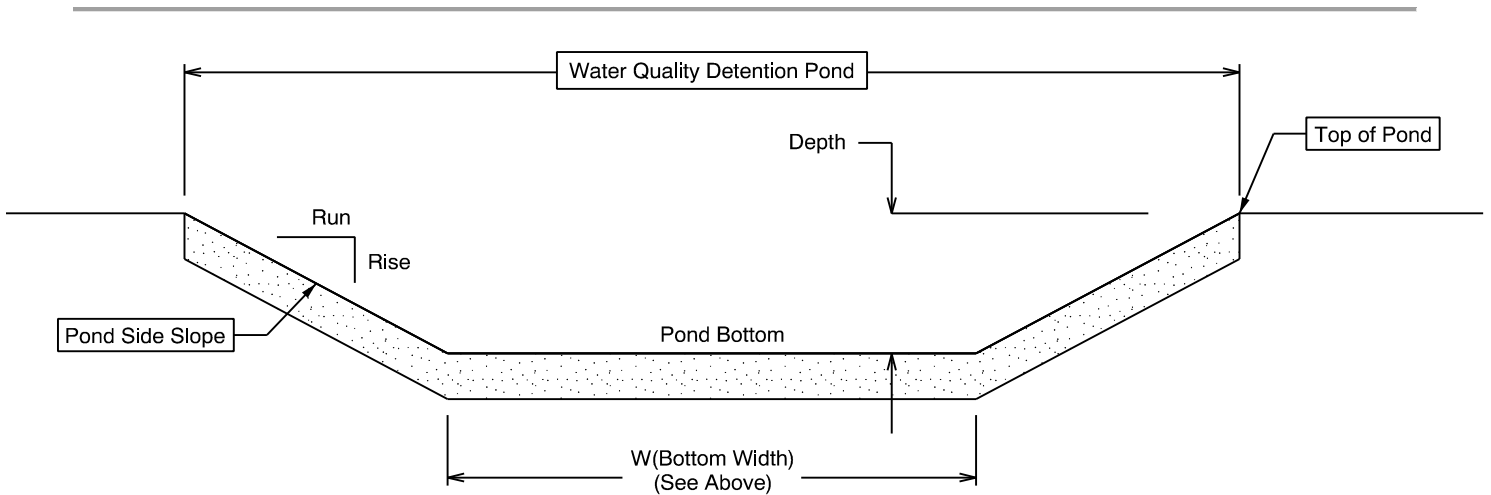

Site Specific Information: Pond is connected to Pond DFI D01343 via an overflow ditch. Water quality material will only be placed up to 1 foot above pond bottom. Pond is placed in a larger deeper basin that is depicted, but what is noted are the general functionality limits of the pond.

Facility Access

Maintenance access to the facility:

<input type="checkbox"/> Roadside pad	<input type="checkbox"/> Roadside shoulder
<input type="checkbox"/> Access road with Gate	<input checked="" type="checkbox"/> Access road without Gate

5. Operational Components / Maintenance Items

Classification and Standard Operational (Op) Plan:

This facility is classified as a:

<input type="checkbox"/> Detention Pond (Op Plan A)	<input checked="" type="checkbox"/> WQ Bioretention Pond (Op Plan B)	<input type="checkbox"/> WQ Extended Detention Dry Pond (Op Plan C)	<input type="checkbox"/> WQ Detention Pond/Biofiltration Swale Combo (Op Plan D)
<p>A standard operational plan illustrates the general facility footprint configuration and explains the purpose of each facility component. Operational plans (A,B,C,D) are provided in the Standard Operation Manual.</p>			

See Appendix A for the site specific operational plan.

Key Features/Items:

This facility is classified as a:

<input checked="" type="checkbox"/> Dry Pond	<input type="checkbox"/> Wet Pond
The pond is wet during storm events and dries during periods of no precipitation.	The pond has constant presence of water year round. A portion of the pond dries during periods of no precipitation.

This facility includes a **high flow bypass component:**

<input checked="" type="checkbox"/> No	<input type="checkbox"/> Yes
There is no bypass component. High flows drains into and through the facility	There is a bypass component. Only low/small flows drain into the pond. High flows are diverted around the pond using a bypass component

This facility includes a **proprietary structure(s)**:

<input checked="" type="checkbox"/> No	<input type="checkbox"/> Yes (DXXXXX)
There are no proprietary structures associated with this facility.	A proprietary structure is used in the operation of this facility. The proprietary structure is a/an: <i>describe</i>

Operational Components

The facility components table (**Table 1**) has been provided to highlight the applicable components for this facility. The component is in use when the box contains an “x” (e.g.).

The Standard Operation Manual for Ponds (implemented *Month YYYY*) outlines facility operation, typical footprint configuration, and component definitions and details. A link to the manual is attached to the feature marker in TransGIS.

<https://gis.odot.state.or.us/TransGIS/>

Maintenance Items

Operational components marked in **Table 1** should be inspected and maintained according to Section 7. Each facility component is defined and detailed in the Standard Operation Manual using the associated ID number indicated in the table below.

Table 1: Stormwater Pond Components		ID #
Upstream Manholes/Structures		
Pre-treatment Manhole Type: <i>describe</i>	<input type="checkbox"/>	P1
Water Quality Manhole Type: <i>describe</i>	<input type="checkbox"/>	P2
Flow Splitter Manhole (<i>Weir/Orifice</i>)	<input type="checkbox"/>	P3
Standard Manhole	<input type="checkbox"/>	P4
Sediment Basin/Forebay	<input type="checkbox"/>	P5
Forebay Dewatering Riser Pipe (outlet)	<input type="checkbox"/>	P6
Facility Inlet		
Pavement Sheet Flow	<input checked="" type="checkbox"/>	P7
Inlet Pipe(s)	<input checked="" type="checkbox"/>	P8
Open Channel Inlet	<input checked="" type="checkbox"/>	P9
Riprap Pad (Energy Dissipater)	<input checked="" type="checkbox"/>	P10
Ground Cover		
Grass Bottom	<input checked="" type="checkbox"/>	P11
Grass Side Slopes	<input checked="" type="checkbox"/>	P12

Granular Drain Rock	<input checked="" type="checkbox"/>	P13
Plantings	<input type="checkbox"/>	P14
Underground Components		
Geotextile Fabric: Type 1	<input checked="" type="checkbox"/>	P15
Impermeable Liner	<input type="checkbox"/>	P16
Water Quality Mix	<input checked="" type="checkbox"/>	P17
Perforated Pipe	<input type="checkbox"/>	P18
Bottom Marker (ex. Porous Pavers)	<input checked="" type="checkbox"/>	P19

Flow Spreader		
Anchored Board (midpoint of pond or every 50 feet along pond bottom)	<input type="checkbox"/>	P20
Other: describe	<input type="checkbox"/>	P21
Facility Outlet		
Catch Basin with Grate	<input type="checkbox"/>	P22
Outlet Pipe(s)	<input type="checkbox"/>	P23
Outlet/Flow Control Structure	<input type="checkbox"/>	P24
Auxiliary Outlet	<input type="checkbox"/>	P25
Hazmat Control Valve: Specify make/model	<input type="checkbox"/>	P26
Outfall Type		
Waterbody (Creek/Lake/Ocean)	<input type="checkbox"/> C	P27
	<input type="checkbox"/> L	
	<input type="checkbox"/> O	
Ditch	<input type="checkbox"/>	P28
Storm Drain System	<input type="checkbox"/>	P29
Outfall Components		
Riprap Pad	<input type="checkbox"/>	P30
Riprap Bank Protection	<input type="checkbox"/>	P31

6. Maintenance

Maintenance Frequency/Maintain Records

- a. Inspect annually. Preferably prior to the rainy season.
- b. Clean and maintain as necessary. Refer to Activity 125 in the Maintenance Guide for conditions when maintenance is needed.
- c. Keep a record of inspections, maintenance, and repairs.

Maintenance Guide/Maintenance Actions

The Maintenance Guide outlines the standard maintenance actions for water quality facilities under Activity 125.

There are standard maintenance tables for standard ODOT designs. The maintenance tables describe the maintenance component, the defect or problem, the condition when maintenance is needed, and the recommended maintenance to correct the problem. Use the following tables to maintain ODOT Ponds:

- Table 1 (General Maintenance): Contains general maintenance and inspection guidelines that are applicable to all ODOT water quality facilities
- Table 2 (Maintenance of Stormwater Ponds): Contains maintenance information for ponds

The ODOT Maintenance Guide can be viewed at the following website:

<http://www.oregon.gov/ODOT/HWY/OOM/pages/mguide.aspx>

The Blue Book can be viewed at the following website:

http://www.oregon.gov/ODOT/Maintenance/Documents/blue_book.pdf

7. Limitations

There are access limitations for this facility:

<input checked="" type="checkbox"/> No	<input type="checkbox"/> Yes
There are no porous pavers installed in this pond.	

Ponds are designed to allow equipment access along the bottom if an access grid is installed. If an access grid is NOT installed, vehicles entering the pond can create depressions (tire ruts), damage vegetation, or damage structural components (e.g. flow spreaders). These conditions may result in poor treatment and drainage performance.

If no access grid then: Equipment wheels should be kept on the tops and side slopes. Mower arms may be run along the pond bottom.

8. Waste Material Handling

Material removed from the facility is defined as waste by the Department of Environmental Quality (DEQ). Refer to the road waste section of the ODOT Maintenance Yard Environmental Management System (EMS) Policy and Procedures Manual for disposal options:

<http://www.oregon.gov/ODOT/HWY/OOM/pages/ems.aspx>

Contact any of the following for more detailed information about management of waste materials found on site:

ODOT Clean Water Unit	(503) 986-3008
ODOT Statewide Hazmat Coordinator	(503) 667-7442
ODOT Region 1 Hazmat Coordinator	(503) 731-8290
ODOT Region 2 Hazmat Coordinator	(503) 986-2647
ODOT Region 3 Hazmat Coordinator	(541) 957-3594
ODOT Region 4 Hazmat Coordinator	(541) 388-6186
ODOT Region 5 Hazmat Coordinator	(541) 963-1590
ODEQ Northwest Region Office	(503) 229-5263

A Appendix A – Site Specific Operational Plan

Contents:

Operational Plan: DFI D01341

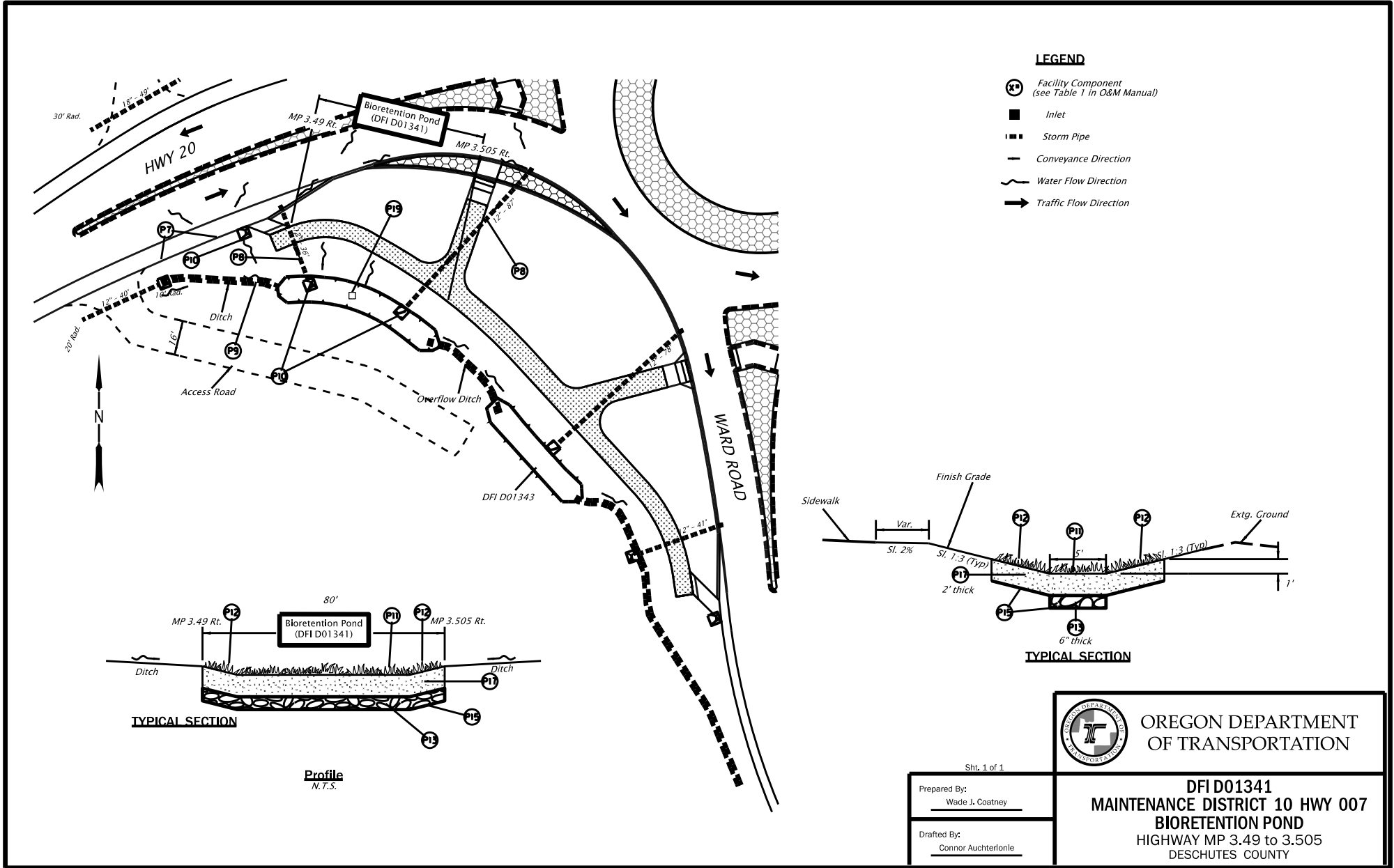

LEGEND

- ⊕ Facility Component (see Table 1 in O&M Manual)
- Inlet
- ▬ Storm Pipe
- Conveyance Direction
- ~ Water Flow Direction
- ➔ Traffic Flow Direction

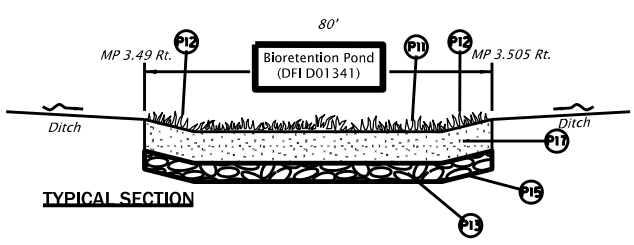
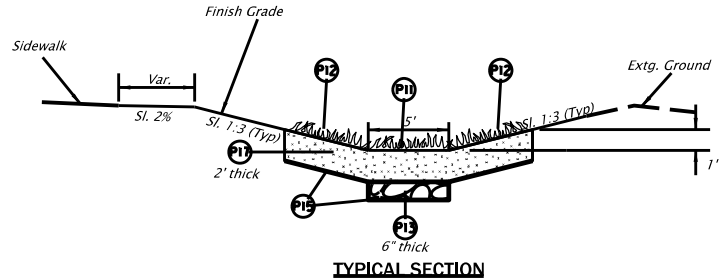

Profile
N.T.S.

 OREGON DEPARTMENT OF TRANSPORTATION	DFI D01341 MAINTENANCE DISTRICT 10 HWY 007 BIORETENTION POND HIGHWAY MP 3.49 to 3.505 DESCHUTES COUNTY
	Prepared By: Wade J. Coatney
Drafted By: Connor Auchtertonle	Sht. 1 of 1

B Appendix B – Project Contract Plans

Contents:

Site Specific Subset of Project Contract Plan

INDEX OF SHEETS	
SHEET NO.	DESCRIPTION
A01	Title Sheet
A02	Index Of Sheets
A03	Std. Dwg. Nos.
A04 thru A07 Incl.	Survey Control Data
A08	Plan Sheet Layout

STATE OF OREGON
DEPARTMENT OF TRANSPORTATION

PLANS FOR PROPOSED PROJECT

**GRADING, DRAINAGE, PAVING, CURB RAMPS, SIGNING,
 ILLUMINATION & ROADSIDE DEVELOPMENT**

US20: WARD / HAMBY RD. INTERSECTION PROJECT
CENTRAL OREGON HIGHWAY

DESCHUTES COUNTY

SEPTEMBER 2021

BEGINNING OF PROJECT

**STA. "L_W" 104+00
 MP 3.26**

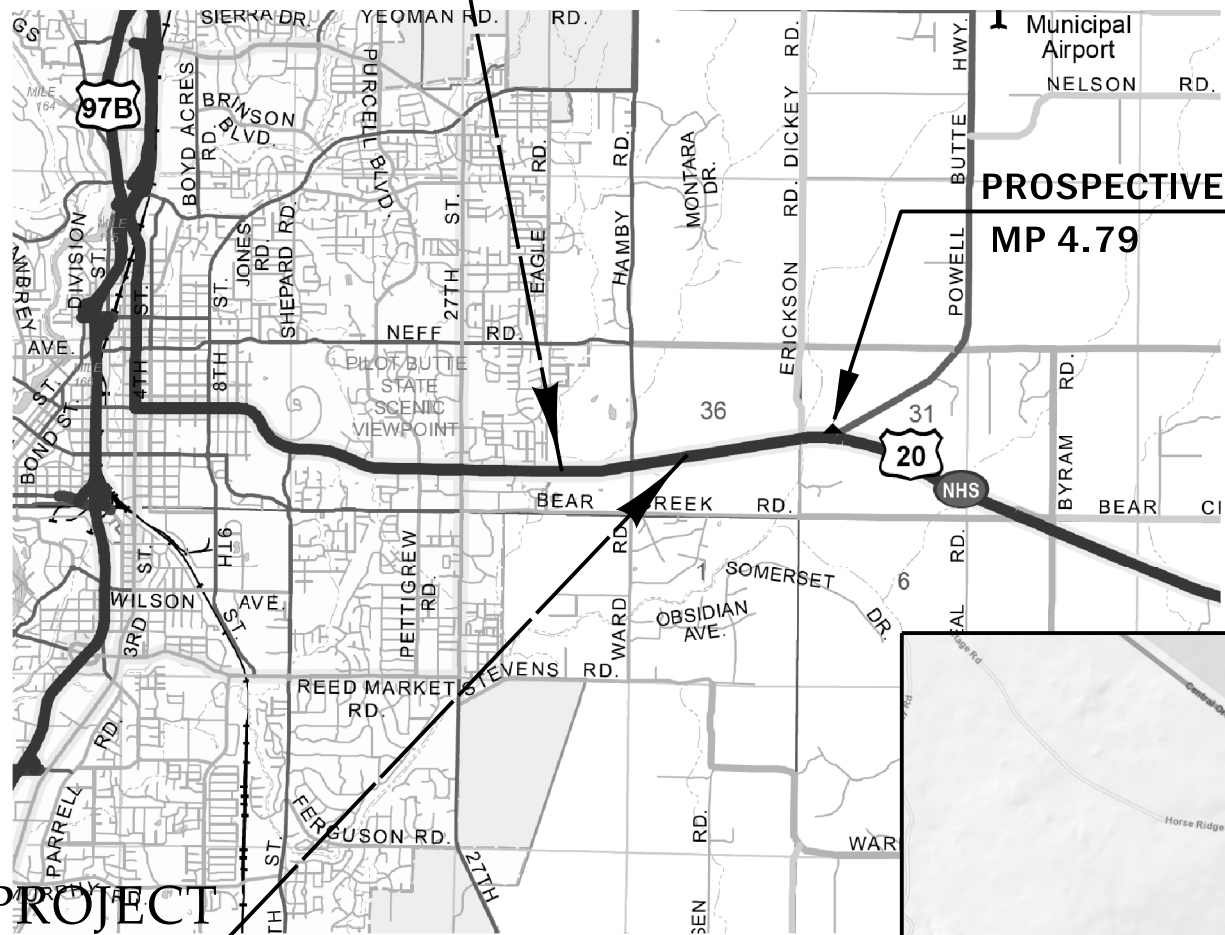

END OF PROJECT

**STA. "L_E" 317+15
 MP 3.86**

**PROSPECTIVE MATERIAL SOURCE
 ARNOLD ICE CAVES
 HWY 007 (CENTRAL OREGON HWY)
 MP 12.60**

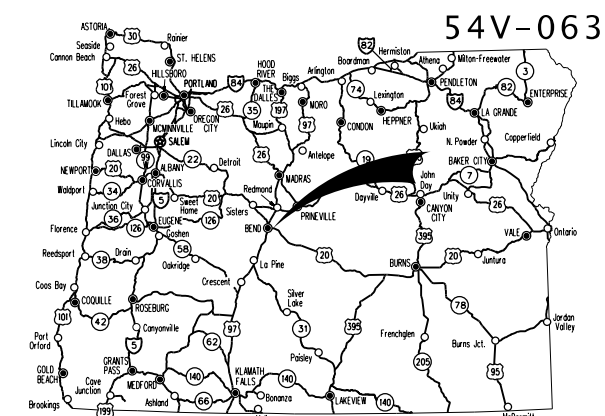

54V-063

Overall Length Of Project - 0.60 Miles

ATTENTION:
 Oregon Law Requires You To Follow Rules Adopted
 By The Oregon Utility Notification Center.
 Those Rules Are Set Forth In OAR 952-001-0001
 Through OAR 952-001-0100.
 You May Obtain Copies Of The Rules By Calling
 The Center (Note: The Telephone Number For
 The Oregon Utility Notification Center Is
 (503) 232-1987).



OREGON TRANSPORTATION COMMISSION
 Robert Van Brocklin CHAIR
 Alando Simpson COMMISSIONER
 Julie Brown COMMISSIONER
 Sharon Smith COMMISSIONER
 Vacant COMMISSIONER
 Kristopher W. Strickler DIRECTOR OF TRANSPORTATION

These plans were developed using ODOT design standards. Exceptions to these standards, if any, have been submitted and approved by the ODOT Chief Engineer or their delegated authority.

Approving Authority: _____
 Signature & date
 Omar Ahmed, Region 4 TCM
 Print name and title

 Concurrence by ODOT Chief Engineer

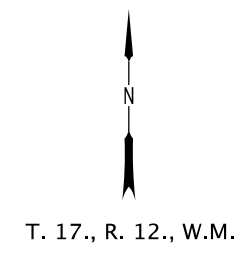

US20: WARD / HAMBY RD. INTERSECTION PROJECT
 CENTRAL OREGON HIGHWAY
 DESCHUTES COUNTY

FEDERAL HIGHWAY ADMINISTRATION	PROJECT NUMBER	SHEET NO.
OREGON DIVISION	S007(084)	A01

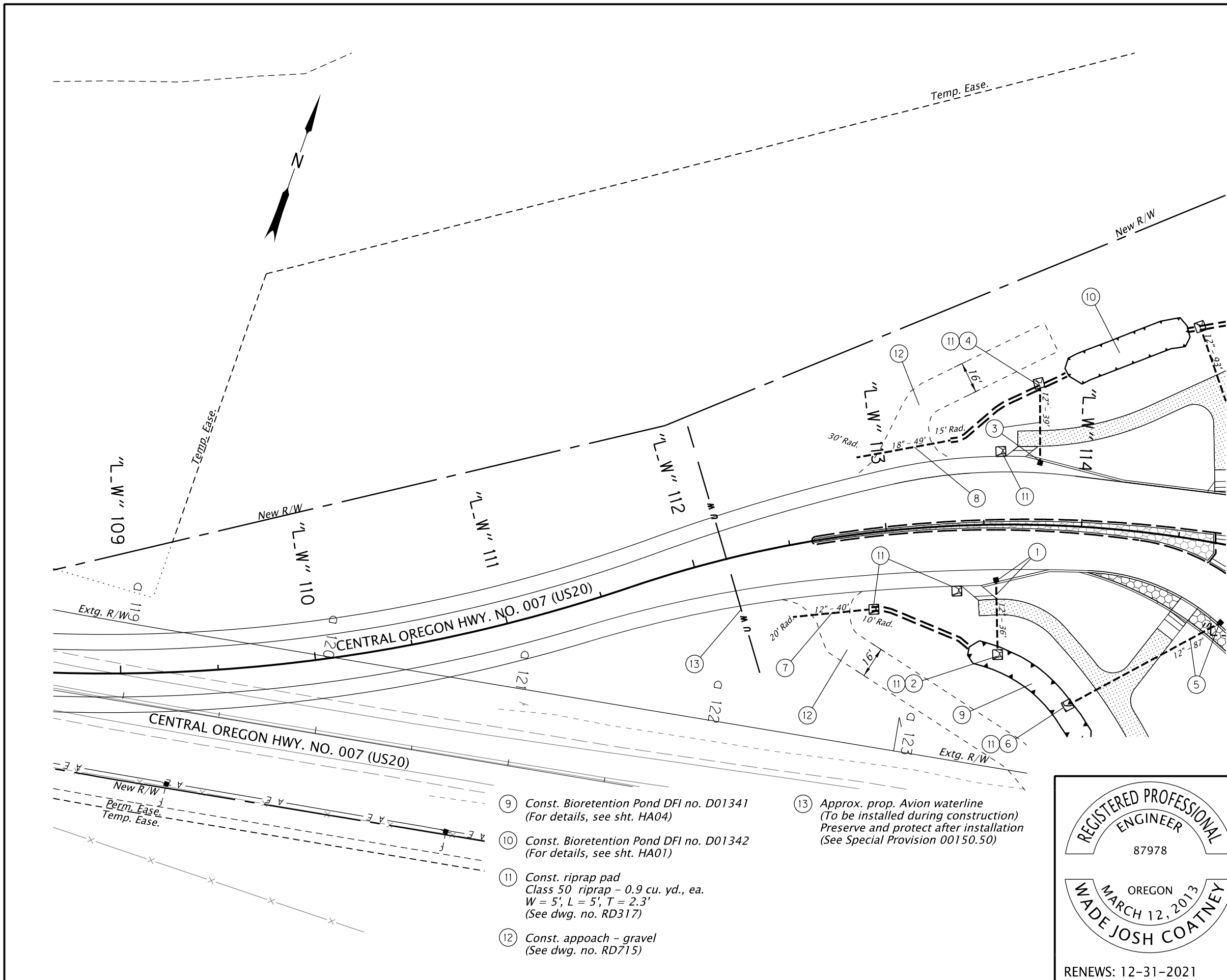

- ① Sta. "L_W" 113+55.94, 28.86' Rt. 54V-063
 Const. Type "G-2" inlet - 2' sump
 I.E. (12" out) = 3613.02 (SW)
 Inst. 12" storm sew. pipe - 36'
 5' depth
 slope = 0.010 ft./ft.
 (See dwg. nos. RD300, RD325, RD326, RD336, RD339, RD363, RD365, RD366, RD380, RD386 & RD388)
- ② Sta. "L_W" 113+56.32, 64.03' Rt.
 I.E. (12" outfall) = 3612.67 (SW)
 Const. sloped end
 (See dwg. nos. RD316, RD318 & RD319)
- ③ Sta. "L_W" 113+78.07, 32.50' Lt.
 Const. Type "G-2" inlet - 2' sump
 I.E. (12" out) = 3613.02 (NW)
 Inst. 12" storm sew. pipe - 39'
 5' depth
 slope = 0.005 ft./ft.
- ④ Sta. "L_W" 113+77.08, 70.02' Lt.
 I.E. (12" outfall) = 3612.84 (NW)
 Const. sloped end
- ⑤ Sta. "L_W" 114+79.01, 40.08' Rt.
 Const. Type "G-2" inlet - 2' sump
 I.E. (12" out) = 3614.13 (SW)
 Inst. 12" storm sew. pipe - 87'
 5' depth
 slope = 0.017 ft./ft.
- ⑥ Sta. "L_W" 114+00.90, 90.25' Rt.
 I.E. (12" outfall) = 3612.69 (SW)
 Const. sloped end
- ⑦ Sta. "L_W" 112+44.47 to Sta. 112+86.11
 Inst. 12" ductile iron pipe - 40'
 5' depth
 slope = 0.011 ft./ft.
 I.E. Inlet = 3613.97 (W)
 I.E. Outfall = 3613.54 (E)
 Const. sloped ends - 2
 (See Dwg. nos. RD319 & RD327)
- ⑧ Sta. "L_W" 112+89.45 to Sta. 113+34.91
 Inst. 18" ductile iron pipe - 49'
 5' depth
 slope = 0.005 ft./ft.
 I.E. In = 3613.51 (W)
 I.E. Out = 3613.27 (E)
 Const. sloped ends - 2

- ⑨ Const. Bioretention Pond DFI no. D01341
 (For details, see sht. HA04)
- ⑩ Const. Bioretention Pond DFI no. D01342
 (For details, see sht. HA01)
- ⑪ Const. riprap pad
 Class 50 riprap - 0.9 cu. yd., ea.
 W = 5', L = 5', T = 2.3'
 (See dwg. no. RD317)
- ⑫ Const. approach - gravel
 (See dwg. no. RD715)
- ⑬ Approx. prop. Avion waterline
 (To be installed during construction)
 Preserve and protect after installation
 (See Special Provision 00150.50)

REGISTERED PROFESSIONAL ENGINEER
 87978
 OREGON
 MARCH 12, 2013
 WADE JOSH COATNEY
 RENEWS: 12-31-2021

OREGON DEPARTMENT OF TRANSPORTATION 	
US20: WARD / HAMBY RD. INTERSECTION PROJECT CENTRAL OREGON HIGHWAY DESCHUTES COUNTY	
Designer: Connor J. Auchterlonie Drafter: Rhonda L. Freeman	Reviewer: Wade J. Coatney Checker: Chad M. Howard
DRAINAGE & UTILITIES	
SHEET NO. CO2A	

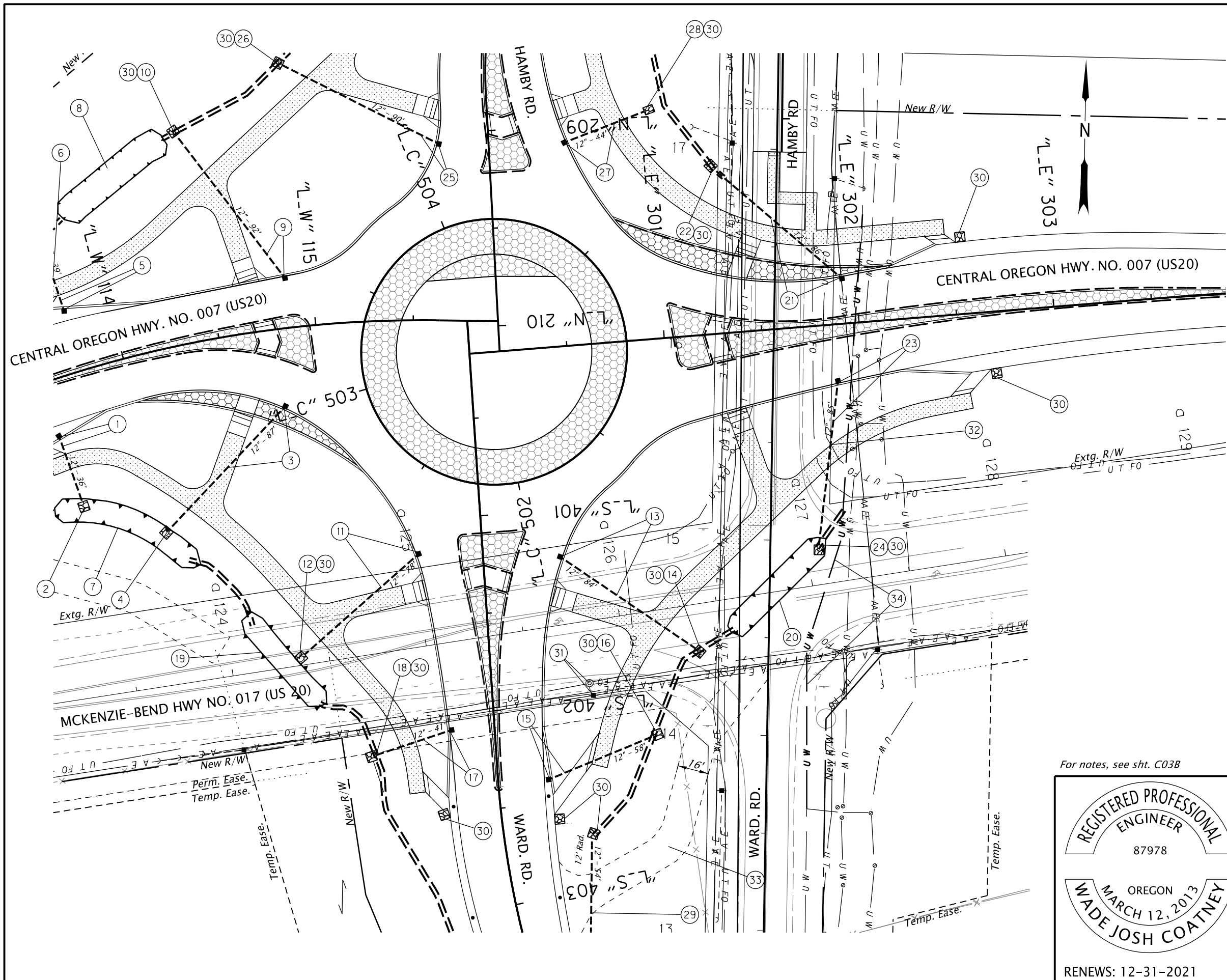

For notes, see sht. C03B

REGISTERED PROFESSIONAL
ENGINEER
87978
OREGON
MARCH 12, 2013
WADE JOSH COATNEY

RENEWS: 12-31-2021

FINAL ELECTRONIC DOCUMENT
AVAILABLE UPON REQUEST

OREGON DEPARTMENT OF TRANSPORTATION		
US20: WARD / HAMBY RD. INTERSECTION PROJECT CENTRAL OREGON HIGHWAY DESCHUTES COUNTY		
Designer: Connor J. Auchterlonie	Reviewer: Wade J. Coatney	SHEET NO. C03A
Drafter: Rhonda L. Freeman	Checker: Chad M. Howard	
DRAINAGE & UTILITIES		

- ① See sht. C02A, note 1
- ② See sht. C02A, note 2 & 11
- ③ See sht. C02A, note 5
- ④ See sht. C02A, note 6 & 11
- ⑤ See sht. C02A, note 3
- ⑥ See sht. C02A, note 4 & 11
- ⑦ See sht. C02A, note 9
- ⑧ See sht. C02A, note 10
- ⑨ Sta. "L_W" 114+87.05, Lt.
Const. Type "G-2" inlet - 2' sump
I.E. (12" out) = 3614.57 (NW)
Inst. 12" storm sew. pipe - 92'
5' depth
slope = 0.021 ft./ft.
- ⑩ Sta. "L_W" 114+46.95, 105.83' Lt.
I.E. (12" outfall) = 3612.65 (NW)
Const. sloped end
- ⑪ Sta. "L_S" 401+17.60 Rt.
Const. Type "G-2" inlet - 2' sump
I.E. (12" out) = 3614.46 (SW)
Inst. 12" storm sew. pipe - 78'
5' depth
slope = 0.015 ft./ft.
- ⑫ Sta. "L_S" 401+64.81, 94.38' Rt.
I.E. (12" outfall) = 3613.28 (SW)
Const. sloped end
- ⑬ Sta. "L_S" 401+23.68, Lt.
Const. Type "G-2" inlet - 2' sump
I.E. (12" out) = 3614.23 (SE)
Inst. 12" storm sew. pipe - 84'
5' depth
slope = 0.014 ft./ft.
- ⑭ Sta. "L_S" 401+75.12, 105.33' Lt.
I.E. (12" outfall) = 3613.10 (SE)
Const. sloped end
- ⑮ Sta. "L_S" 402+37.37, Lt.
Const. Type "G-2" inlet - 2' sump
I.E. (12" out) = 3613.20 (NE)
Inst. 12" storm sew. pipe - 58'
5' depth
slope = 0.005 ft./ft.
- ⑯ Sta. "L_S" 402+18.58, 80.7' Lt.
I.E. (12" outfall) = 3612.91 (NE)
Const. sloped end
- ⑰ Sta. "L_S" 402+08.48, Rt.
Const. Type "G-2" inlet - 2' sump
I.E. (12" out) = 3613.61 (SW)
Inst. 12" storm sew. pipe - 41'
5' depth
slope = 0.006 ft./ft.
- ⑱ Sta. "L_S" 402+18.64, 61.41' Rt.
I.E. (12" outfall) = 3613.38 (SW)
Const. sloped end
- ⑲ Const. Bioretention Pond DFI no. D01343
(For details, see sht. HA04)
- ⑳ Const. Bioretention Pond DFI no. D01345
(For details, see sht. HA03)
- ㉑ Sta. "L_E" 301+92.97, Lt.
Const. Type "G-2" inlet - 2' sump
I.E. (12" out) = 3613.15 (NE)
Inst. 12" storm sew. pipe - 86'
5' depth
slope = 0.008 ft./ft.
- ㉒ Sta. "L_E" 301+32.37, 84.02' Lt.
I.E. (12" outfall) = 3612.48 (NE)
Const. sloped end
- ㉓ Sta. "L_E" 301+87.00, Rt.
Const. Type "G-2" inlet - 2' sump
I.E. (12" out) = 3613.14 (SW)
Inst. 12" storm sew. pipe - 85'
5' depth
slope = 0.005 ft./ft.
- ㉔ Sta. "L_E" 301+70.40, 111.95' Rt.
I.E. (12" outfall) = 3612.72 (SW)
Const. sloped end
- ㉕ Sta. "L_N" 209+05.30, Rt.
Const. Type "G-2" inlet - 2' sump
I.E. (12" out) = 3614.53 (NW)
Inst. 12" storm sew. pipe - 90'
5' depth
slope = 0.011 ft./ft.
- ㉖ Sta. "L_N" 208+67.51, 103.87' Rt.
I.E. (12" outfall) = 3613.56 (NW)
Const. sloped end
- ㉗ Sta. "L_N" 209+08.10, Lt.
Const. Type "G-2" inlet - 2' sump
I.E. (12" out) = 3614.32 (NE)
Inst. 12" storm sew. pipe - 44'
5' depth
slope = 0.020 ft./ft.
- ㉘ Sta. "L_N" 208+94.50, 80.43' Lt.
I.E. (12" outfall) = 3613.45 (NE)
Const. sloped end
- ㉙ Sta. "L_S" 403+28.71 to Sta. 402+72.16
Inst. 12" ductile iron pipe - 54'
5' depth
slope = 0.009 ft./ft.
I.E. Inlet = 3614.27 (S)
I.E. Outfall = 3613.80 (E)
Const. sloped ends - 2
- ㉚ Const. riprap pad
Class 50 riprap - 0.9 c.u. yd., ea.
W = 5', L = 5', T = 2.3'
- ㉛ Protect in place
- ㉜ Adjust LS Networks flexible conduit to suit
Anticipated exc. 12 cu.yd.
- ㉝ Const. approach - gravel
- ㉞ Approx. prop. Avion waterline
(To be installed during construction)
Preserve and protect after installation
(See Special Provision 00150.50)

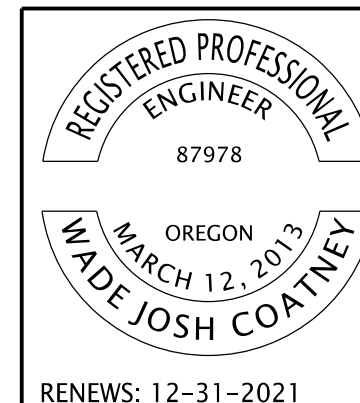

OREGON DEPARTMENT OF TRANSPORTATION	
US20: WARD / HAMBY RD. INTERSECTION PROJECT CENTRAL OREGON HIGHWAY DESCHUTES COUNTY	
Designer: Connor J. Auchterlonie Drafter: Rhonda L. Freeman	Reviewer: Wade J. Coatney Checker: Chad M. Howard
DRAINAGE & UTILITIES NOTES	
SHEET NO. C03B	

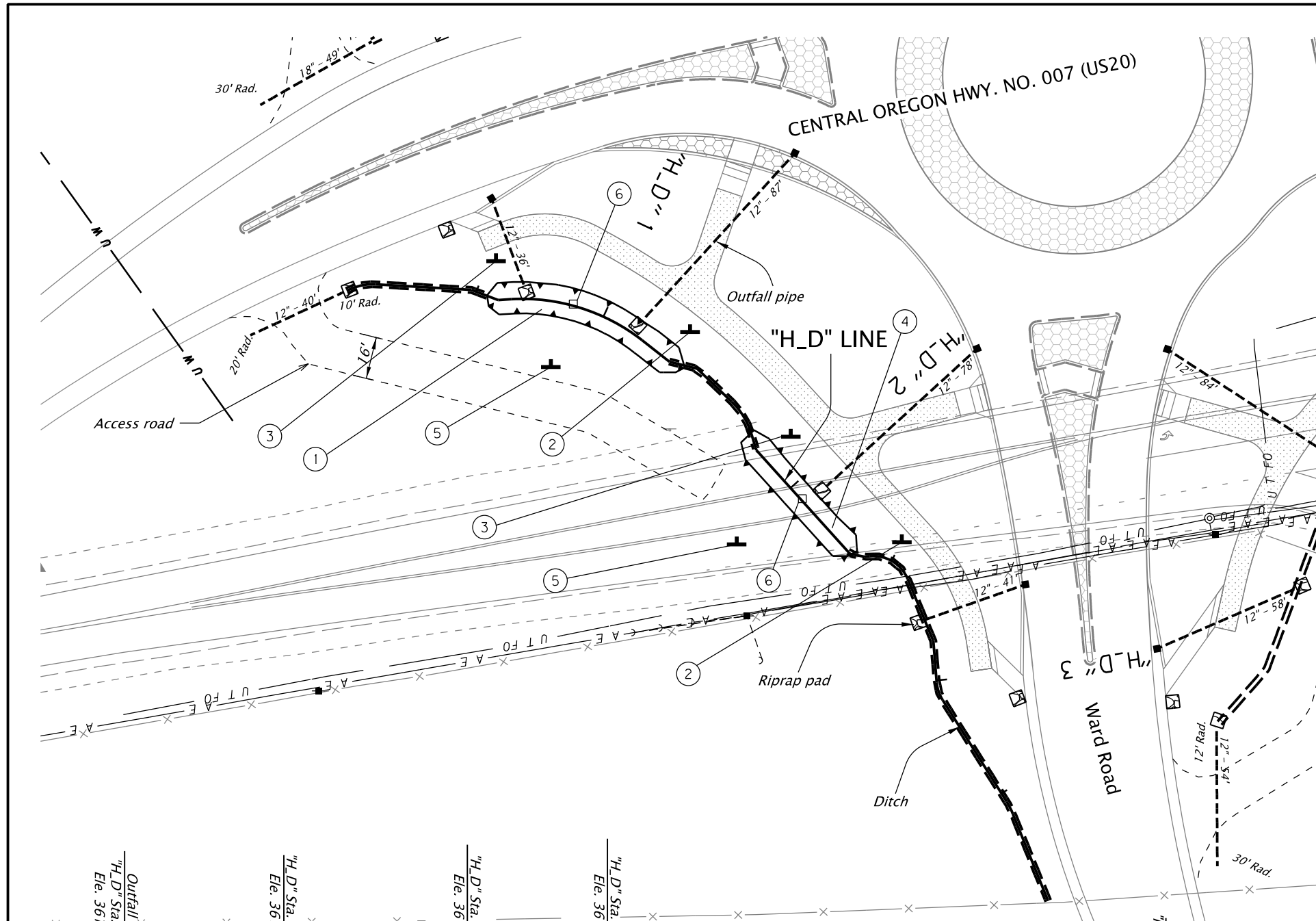

- ① Sta. "H_D" 0+58.92 to 1+30.34
Const. Bioretention Pond DFI no. D01341
- ② Inst. field facility marker - 2
Type S1, green
- ③ Inst. field facility marker - 2
Type S1, red
- ④ Sta. "H_D" 1+80.53 to 2+32.70
Const. Bioretention Pond DFI no. D01343
- ⑤ Inst. field facility marker - 2
Type S2
- ⑥ Const. conc. bottom marker - 2
3'x3'x4"
Elev. - match pond bottom

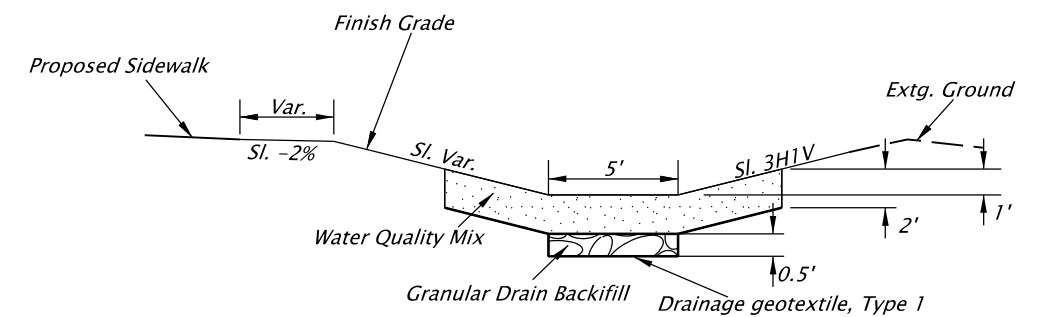

"H_D" Sta. 0+60.68 to 1+30.55
"H_D" Sta. 1+83.91 to 2+32.70

TYPICAL SECTION

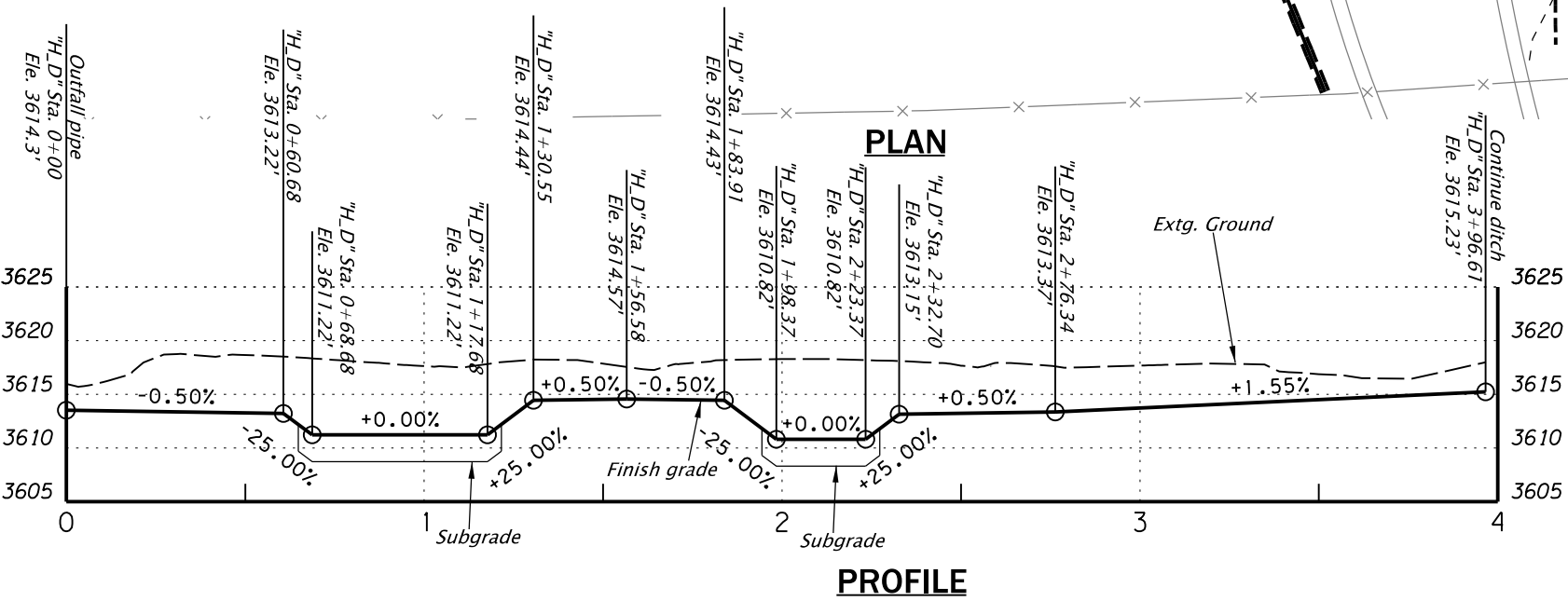

General Notes:

- 1. Excavation to finish grade, including ditch excavation will be paid with earthwork pay items. For quantities, see Roadway Sheets.
- 2. For ditch details, see Typical Sections

REGISTERED PROFESSIONAL ENGINEER
87978
OREGON
MARCH 12, 2013
WADE JOSH COATNEY

OREGON DEPARTMENT OF TRANSPORTATION 	
US20: WARD / HAMBY RD. INTERSECTION PROJECT CENTRAL OREGON HIGHWAY DESCHUTES COUNTY	
Designer: Connor J. Auchterlonie Drafter: Rhonda L. Freeman	Reviewer: Wade J. Coatney Checker: Chad M. Howard
STORMWATER PLAN	
SHEET NO. HA04	

RENEWS: 12-31-2021

FINAL ELECTRONIC DOCUMENT
AVAILABLE UPON REQUEST