

OPERATION & MAINTENANCE MANUAL

**DFI Nos. : D00974, D00975, D00976,
D00978, and planters along Industrial
Parkway and Springbrook Road**

**Facility Type: Newberg Dundee
Bypass Water Quality Bio-infiltration
Planters**

**(Planters: refer sheets GJ, GJ-2, GJ-
3, GJ-4, GJ-9, GJ-11, 16B, 16B-2, 16D,
17B, 17B-2, 17D, 18B, 18B-2, 18D,
19B, 19B-2, 19D and 19F in attached
plans)**

[January 2019]

INDEX

1. IDENTIFICATION..... 1
2. FACILITY CONTACT INFORMATION 1
3. CONSTRUCTION..... 2
4. STORM DRAIN SYSTEM AND FACILITY OVERVIEW 2
5. FACILITY HAZ MAT SPILL FEATURE(S)..... 3
6. AUXILIARY OUTLET (HIGH FLOW BYPASS)..... 3
7. MAINTENANCE REQUIREMENTS..... 3
8. WASTE MATERIAL HANDLING..... 6

APPENDIX A: O&M Plan and Detail Drawing(s)
APPENDIX B: Plans and Detail Drawing(s)
APPENDIX C: Maintenance Tables

1. Identification

Drainage Facility ID (DFI): [D00974, D00975, D00976, D00978, planters along Industrial Parkway and Springbrook Road]

Facility Type: [Bio-infiltration Planter]

Construction Drawings: [49V-017]

Location: District: 3

Highway No.: 219

Mile Post: [21.46; 21.61, left (beg./end)]

[21.63; 21.74, left (beg./end)]

[21.69; 21.86, left (beg./end)]

[21.58; 21.60, right (beg./end)]

Description: Facilities with DFI numbers are located along 219 north and south of the intersection with Springbrook Road and Industrial Parkway. Two planters are located along Industrial Parkway at the intersection with 219. Planters along Springbrook Road are located on the east and west side between 99W and 219.

2. Facility Contact Information

Contact the Engineer of Record, Region Technical Center, or Geo-Environmental's Senior Hydraulics Engineer for:

- Operational clarification
- Maintenance clarification
- Repair or restoration assistance

Engineering Contacts:

Region Technical Center Hydro Unit Manager

Or

Geo-Environmental Senior Hydraulics Engineer (503) 986-3365.

3. Construction

Engineer of Record: Consultant Designer – Parametrix, Rebecca Cushman, PE, 206-394-3679
Facility construction: 2016/2017
Contractor: K&E Excavating, Inc.
Salem, Oregon.

4. Storm Drain System and Facility Overview

The featured bio-infiltration planters (referred to from this point forward as planters) functions both as a water quality treatment and some volumetric retention/detention facility. The facility provides water quality treatment of smaller storm events and retention/detention of the larger storm events. Suspended solids and pollutants are filtered out through a compost amended soil medium at the bottom of the planter. Larger storm events are detained within the planter to a depth of 2 inches, then infiltrated through the growing medium or overflows to an inlet then drains to the outlet. These facilities are designed to completely drain over a 48 hour period.

The following elements are included with this document. Additional information can be found in the supporting drainage report '*Drainage report to support phase 1G final stormwater management facility design, November, 2015*'.

A. Maintenance equipment access:

The water quality treatment compost medium in the planters is not to be compacted. Therefore tracked or tired equipment (equipment) is not allowed in the planters.

B. Heavy equipment access into facility:

- Allowed (no limitations)
- Allowed (with limitations)
- Not allowed

C. Special Features:

- Amended Soils
- Porous Pavers
- Liners
- Underdrains

5. Facility Haz Mat Spill Feature(s)

The bio-infiltration planter is not to be used as a hazardous material containment facility. The facility should be protected from hazardous material spills and contamination. A hazardous material spill plan should include protecting the planter from contamination.

6. Auxiliary Outlet (High Flow Bypass)

Auxiliary Outlets are provided if the primary outlet cannot safely pass the projected high flows. The primary outlet for high flows, when the infiltration rate of the growing medium is exceeded, is an inlet at the end of each planter. During exceedingly large event or if an inlet is plugged the stormwater runoff will exit the planter at the most downstream curb cut and travel along the road and enter the next planter.

The auxiliary outlet feature for this facility is:

Designed into facility

An inlet is built into the planter as the outlet to pass events larger than water quality event. The design event will enter the outlet and pass through the conveyance system. Should the inlet capacity become insufficient, excess flow will bypass through the curb cut and flow down to the next planter.

Other, as noted below

7. Maintenance Requirements

Routine maintenance tables for non-proprietary stormwater treatment and storage/detention facilities have been incorporated into ODOT's Maintenance Guide. These tables summarize the maintenance requirements for ponds, swales, filter strips, bioslopes, and detention tanks and vaults. Special maintenance requirements in addition to the routine requirements are noted below when applicable.

The ODOT Maintenance Guide can be viewed at the following website:

<http://www.oregon.gov/ODOT/HWY/OOM/Pages/MGuide.aspx>

The following stormwater facility maintenance table (See ODOT Maintenance Guide) should be used to maintain the facility outlined in this Operation and Maintenance Manual. The selected tables are provided and attached to this manual:

Mark as Required and always include Table 1:

- Table 1 (general maintenance)
- Table 2 (stormwater ponds)
- Table 3 (water quality bio-infiltration swales)
- Table 4 (water quality filter strips)
- Table 5 (water quality bioslopes)
- Table 6 (detention tank)
- Table 7 (detention vault)
- Appendix C (proprietary structure)
- Special Maintenance Requirements

All facility components, site and vegetation shall be inspected for proper operation and structural stability. These inspections shall occur, at a minimum, quarterly for the first 2 years from the date of installation, and two times per year thereafter, and within 48 hours after each major storm event. The items are described and arranged by component of the proposed bio-infiltration planters.

The inlet (curb cut) is required to have unrestricted flow to planters.

- Curb cut shall be cleared when conveyance capacity is compromised.
- Determine if opening is in good condition:
 - Remove any sediment built up at the curb cut
 - Inspect structural integrity of curb cut
 - If cracks or openings exist indicated by evidence of erosion at leaks, repair or replace concrete as needed
- Structural deficiencies shall be corrected upon discovery:
 - If cracks exist, repair or replace structure.
 - If erosion channels deeper than 2 inches exist, stabilize surface and identify source to correct the structure.

Structural deficiencies shall be corrected upon discovery:

- If cracks exist, repair or replace structure.
- Repair or replace structures and pipes as necessary with similar components.
- Remove obstructions to restore flow (e.g., remove trash, debris, sediment, or vegetation as necessary).
- Jet rodders may be used to clean piping unless specifically prohibited.
- For outfall, when there is insufficient rock armoring:
 - Install erosion control measures.
 - Repair or replace rock armoring to original design standard.
 - Repair, re-grade, and reseed eroded areas adjacent to rock armoring.

- Contact a region hydraulics engineer for technical assistance if rock armoring problems continue or a highway structure is at risk.

The outlet structure conveys flow exceeding soil infiltration to the control structure and ultimately the receiving water body.

- Sources of erosion damage shall be identified and controlled when native soil is exposed at the time of the outlet structure or erosion channels are or have formed.
- Rocks or other armament shall be replaced when only one layer of rock exists above native soil.
- Persistent standing water may indicate the under drain is fouled and should be inspected for obstructions and ensure capacity is restored.

Sediment and debris management shall prevent loss of function caused by sedimentation.

- Planters shall have growing medium and drain rock removed and replaced when infiltration becomes compromised. Planters should empty within several hours after a rain event.
- Sources of restricted sediment or debris, such as discarded lawn clipping, shall be identified and prevented.
- Fine sediment that settles on the surface of the planter should be removed.
- Debris in quantities sufficient to inhibit operation shall be removed routinely, e.g., no less than quarterly, or upon discovery.
- Litter shall be removed upon discovery.

Vegetation shall be healthy and dense enough to provide filtering while protecting underlying soils from erosion.

- Vegetation, large shrubs or trees that limit access or interfere with planter operation shall be pruned.
- Fallen leaves and debris from deciduous plant foliage shall be raked and removed.
- Dead vegetation shall be removed to maintain less than 10 percent of area coverage or when planter function is impaired. Vegetation shall be replaced within 3 months or immediately if required to maintain cover density and control erosion where soils are exposed.
- Vegetation producing foul odors shall be eliminated.
- Planter should not be mowed.

Insects and rodents shall not be harbored in the planter. Pest control measures shall be taken when insects and rodents are found to be present. Holes in the ground located in and around the constructed treatment planter shall be filled.

Flooding:

- Check storm drainpipes and structures for blockage. Remove obstructions to restore flow.
- Evaluate and remove excessive sediment from planter areas.
- Contact the region hydraulic engineer to evaluate the source of flooding or provide design modifications.

8. Waste Material Handling

Material removed from the facility is defined as waste by DEQ. Refer to the road waste section of the ODOT Maintenance Yard Environmental Management System (EMS) Policy and Procedures Manual for disposal options: <http://egov.oregon.gov/ODOT/HWY/OOM/EMS.shtml>

Contact any of the following for more detailed information about management of waste materials found on site:

ODOT Clean Water Unit	(503) 986-3008
ODOT Statewide Hazmat Coordinator	(503) 229-5129
ODOT Region Hazmat Manager	(503) 986-2990
ODEQ Northwest Region Office	(503) 229-5263

Appendix A

Content:

- O&M Plans and Detail Drawing(s)

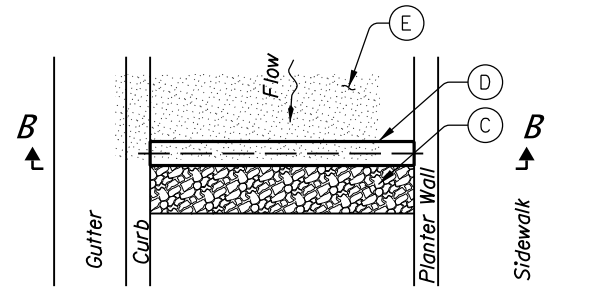

PLAN
N.T.S.

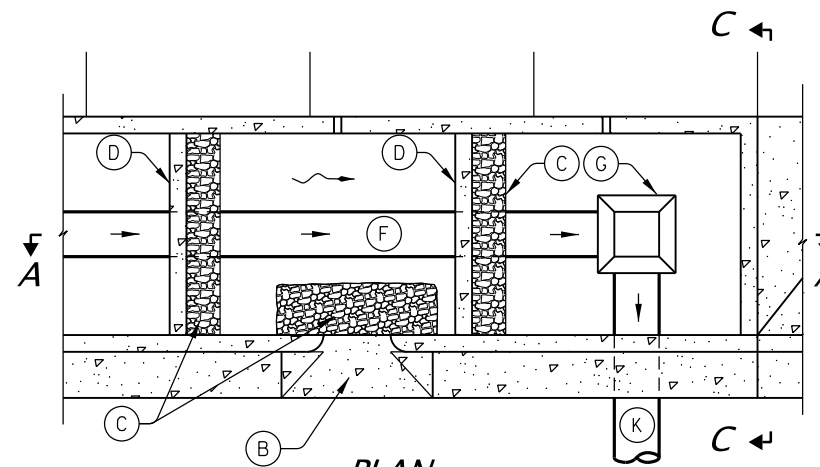

PLAN
N.T.S.

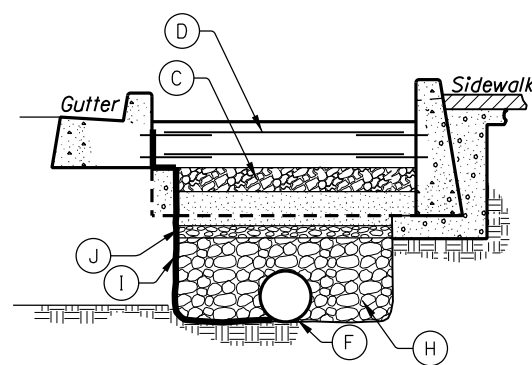

SECTION B-B
N.T.S.

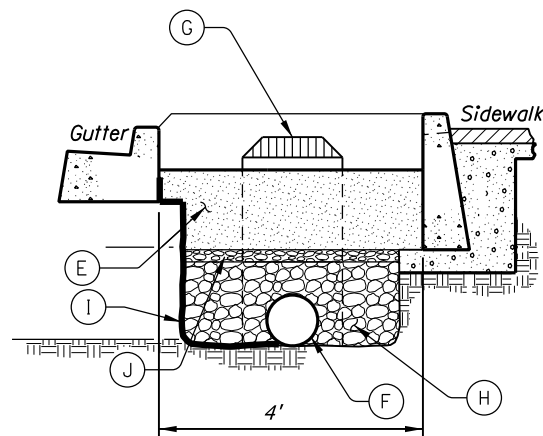

SECTION C-C
N.T.S.

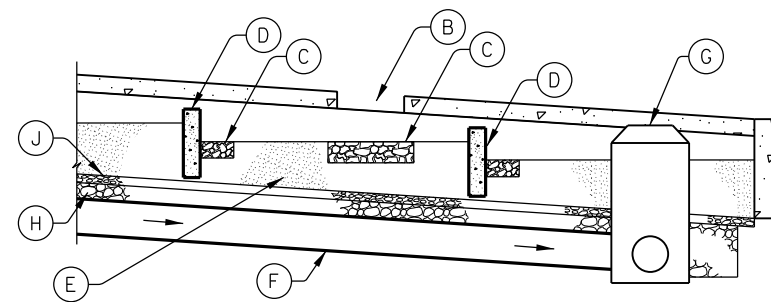

SECTION A-A
N.T.S.

LEGEND:

- (A) Biofiltration Planter
- (B) Curbcut Inlet
- (C) RipRap
- (D) Concrete Check Dam
- (E) Water Quality Mixture
Nom. Thickness 18"
- (F) Under Drain
- (G) Type 3 Catchbasin (modified)
with Behve Grate
- (H) Granular Drain Backfill
Nom. Thickness 18"
- (I) Waterproff Geomembrane
- (J) No. 4 Opengraded Aggregate
Nom. Thickness 3"
- (K) Drain to Conveyance Line
- and ⊙ or ⊕ and ⊗ Manhole
- and □ or ⊠ and ⊞ Inlet
- Storm Pipe (Facility)
- - - Storm Pipe
- Conveyance Direction
- ~ Pavement / Facility Flow Path
- ⇐ Traffic Flow Direction

Sht. ## of ##

Prepared By:
R. CUSHMAN

Drafted By:
D. GODFREY



OREGON DEPARTMENT
OF TRANSPORTATION

DFI D00974, 975, 976, 978
MAINTENANCE DISTRICT 3 HWY 140
WATER QUALITY BIOFILTRATION PLANTER
HILLSBORO-SILVERTON HWY MP21.46-MP21.61
YAMHILL COUNTY

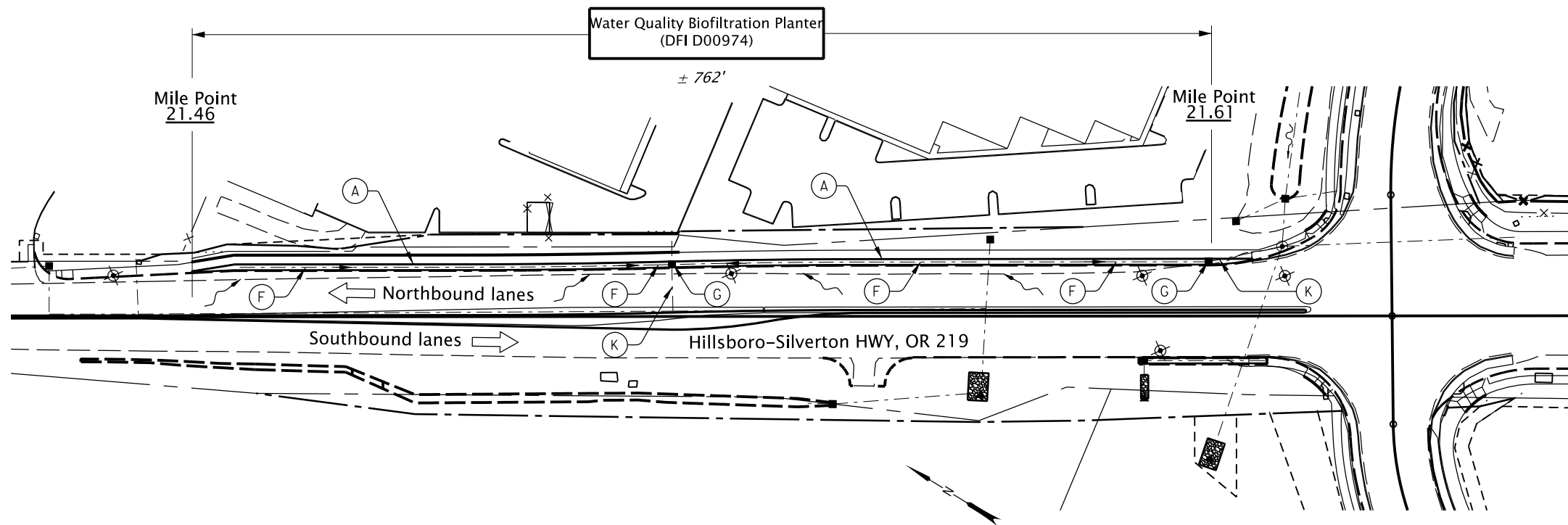

PLAN
N.T.S.

LEGEND:

- (A) Biofiltration Planter
- (B) Curbscut Inlet
- (C) RipRap
- (D) Concrete Check Dam
- (E) Water Quality Mixture
Nom. Thickness 18"
- (F) Under Drain
- (G) Type 3 Catchbasin (modified)
with Behive Grate
- (H) Granular Drain Backfill
Nom. Thickness 18"
- (I) Waterproff Geomembrane
- (J) No. 4 Opengraded Aggregate
Nom. Thickness 3"
- (K) Drain to Conveyance Line
- and ○ Manhole
- and □ Inlet
- Storm Pipe (Facility)
- - - Storm Pipe
- Conveyance Direction
- ~ Pavement / Facility Flow Path
- ⇐ Traffic Flow Direction



OREGON DEPARTMENT
OF TRANSPORTATION

Sht. ## of ##

Prepared By:
R. CUSHMAN

Drafted By:
D. GODFREY

DFI D00974
MAINTENANCE DISTRICT 3 HWY 140
WATER QUALITY BIOFILTRATION PLANTER
HILLSBORO-SILVERTON HWY MP21.46-MP21.61
YAMHILL COUNTY

Water Quality Biofiltration Planter
(DFI D00975)

± 581'

Mile Point
21.63

Mile Point
21.74

Northbound lanes ←

Hillsboro-Silverton HWY, OR 219

Southbound lanes →

LEGEND:

- (A) Biofiltration Planter
- (B) Curbcut Inlet
- (C) RipRap
- (D) Concrete Check Dam
- (E) Water Quality Mixture
Nom. Thickness 18"
- (F) Under Drain
- (G) Type 3 Catchbasin (modified)
with Behive Grate
- (H) Granular Drain Backfill
Nom. Thickness 18"
- (I) Waterproff Geomembrane
- (J) No. 4 Opengraded Aggregate
Nom. Thickness 3"
- (K) Drain to Conveyance Line

- and ⊙ Manhole
- and □ Inlet
- Storm Pipe (Facility)
- - - Storm Pipe
- Conveyance Direction
- ~ Pavement / Facility Flow Path
- ← Traffic Flow Direction

PLAN
N.T.S.



OREGON DEPARTMENT
OF TRANSPORTATION

Sht. ## of ##

Prepared By:
R. CUSHMAN

Drafted By:
D. GODFREY

DFI D00975
MAINTENANCE DISTRICT 3 HWY 140
WATER QUALITY BIOFILTRATION PLANTER
HILLSBORO-SILVERTON HWY MP21.63-MP21.74
YAMHILL COUNTY

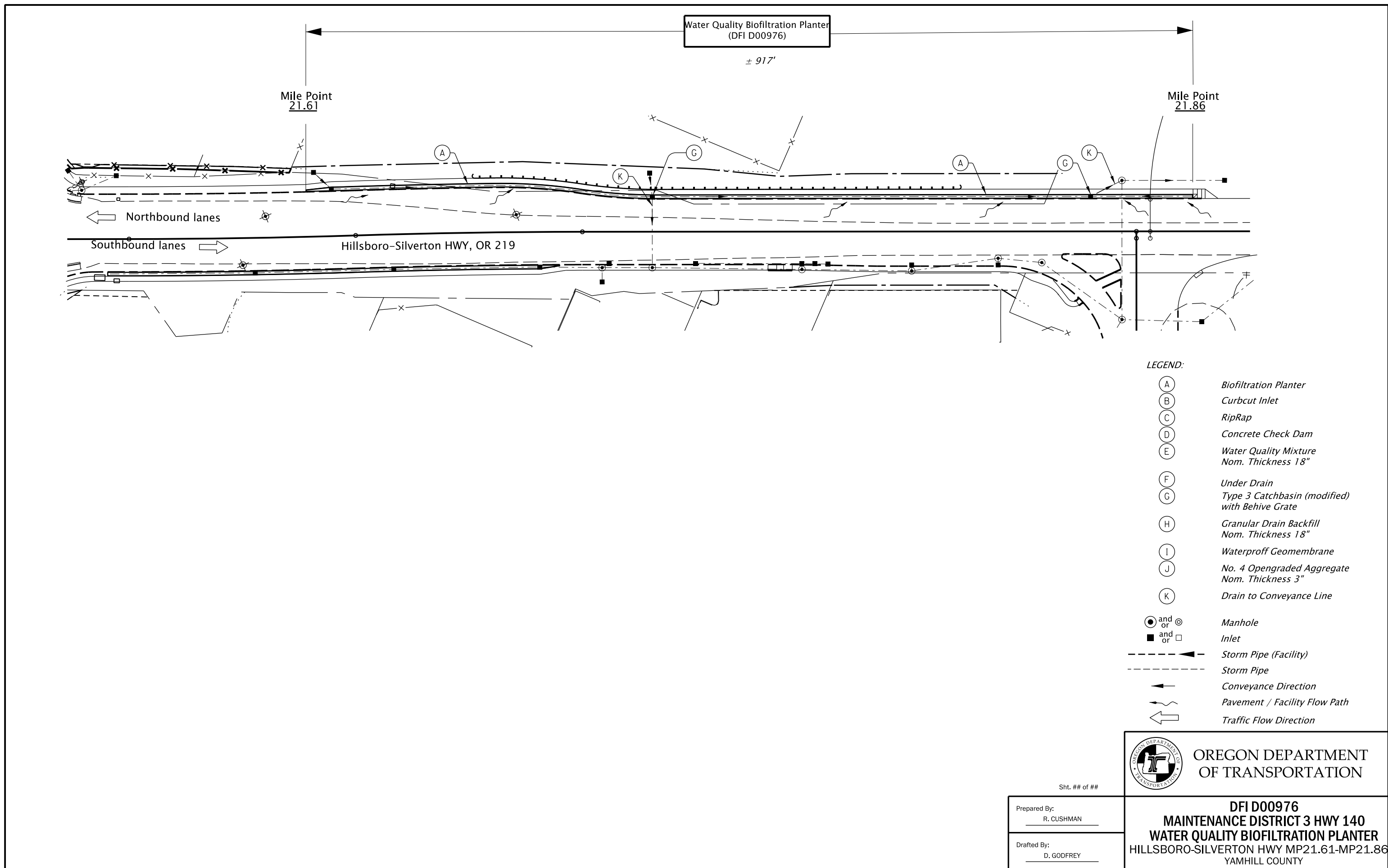

Water Quality Biofiltration Planter
(DFI D00976)

± 917'

Mile Point
21.61

Mile Point
21.86

Northbound lanes ←

Southbound lanes →

Hillsboro-Silverton HWY, OR 219

LEGEND:

- (A) Biofiltration Planter
- (B) Curbcut Inlet
- (C) RipRap
- (D) Concrete Check Dam
- (E) Water Quality Mixture
Nom. Thickness 18"
- (F) Under Drain
- (G) Type 3 Catchbasin (modified)
with Behive Grate
- (H) Granular Drain Backfill
Nom. Thickness 18"
- (I) Waterproff Geomembrane
- (J) No. 4 Opengraded Aggregate
Nom. Thickness 3"
- (K) Drain to Conveyance Line
- and ⊙ Manhole
- and □ Inlet
- Storm Pipe (Facility)
- - - Storm Pipe
- Conveyance Direction
- ~ Pavement / Facility Flow Path
- ⇐ Traffic Flow Direction



OREGON DEPARTMENT
OF TRANSPORTATION

Sht. ## of ##

Prepared By:
R. CUSHMAN

Drafted By:
D. GODFREY

DFI D00976
MAINTENANCE DISTRICT 3 HWY 140
WATER QUALITY BIOFILTRATION PLANTER
HILLSBORO-SILVERTON HWY MP21.61-MP21.86
YAMHILL COUNTY

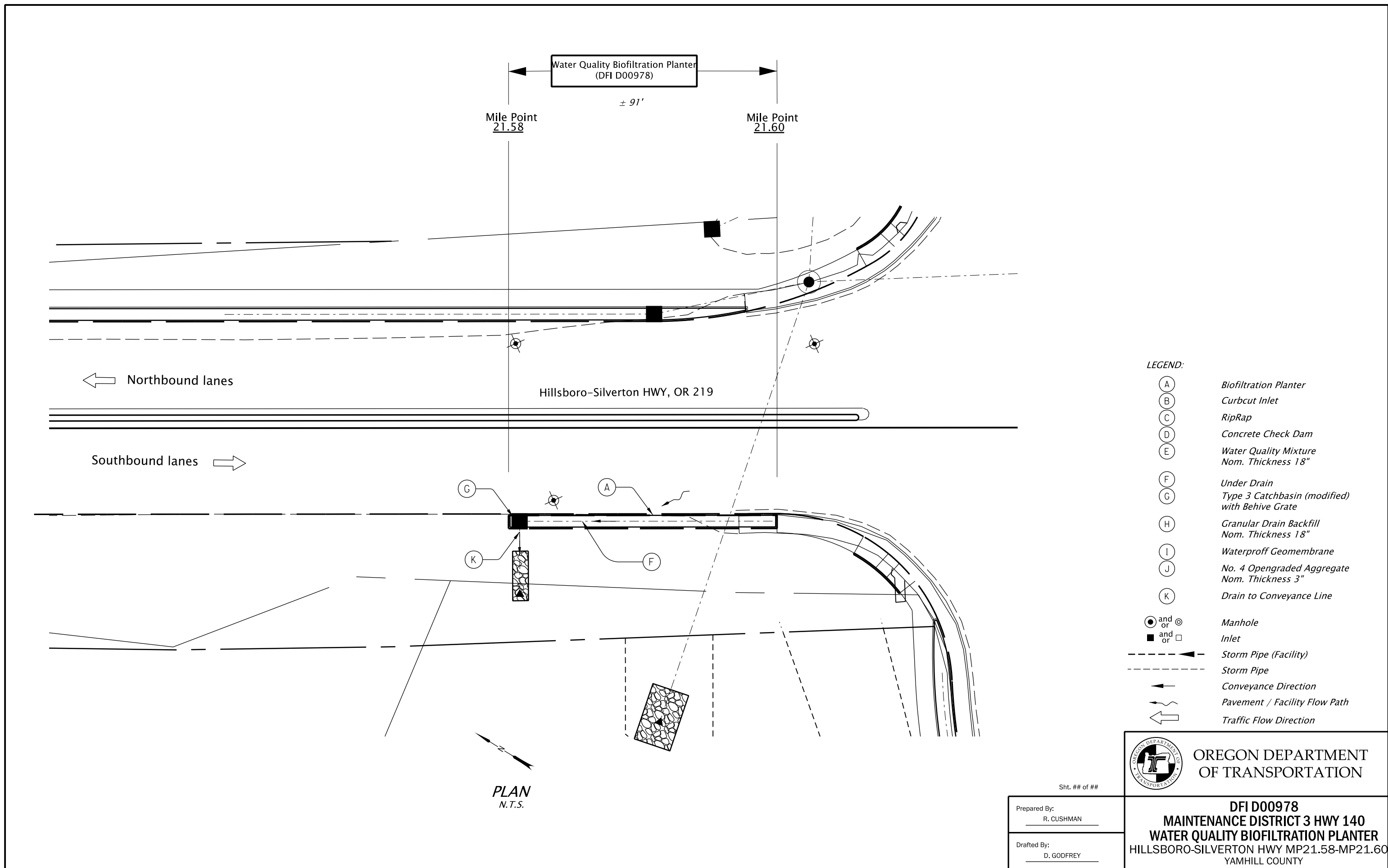

- LEGEND:**
- (A) Biofiltration Planter
 - (B) Curbcut Inlet
 - (C) RipRap
 - (D) Concrete Check Dam
 - (E) Water Quality Mixture
Nom. Thickness 18"
 - (F) Under Drain
 - (G) Type 3 Catchbasin (modified)
with Behve Grate
 - (H) Granular Drain Backfill
Nom. Thickness 18"
 - (I) Waterproff Geomembrane
 - (J) No. 4 Opengraded Aggregate
Nom. Thickness 3"
 - (K) Drain to Conveyance Line
 - and ○ Manhole
 - and □ Inlet
 - Storm Pipe (Facility)
 - - - Storm Pipe
 - Conveyance Direction
 - Pavement / Facility Flow Path
 - ← Traffic Flow Direction

PLAN
N.T.S.

Sht. ## of ##

Prepared By:
R. CUSHMAN

Drafted By:
D. GODFREY



OREGON DEPARTMENT OF TRANSPORTATION

DFI D00978
MAINTENANCE DISTRICT 3 HWY 140
WATER QUALITY BIOFILTRATION PLANTER
 HILLSBORO-SILVERTON HWY MP21.58-MP21.60
 YAMHILL COUNTY

Appendix B

Content:

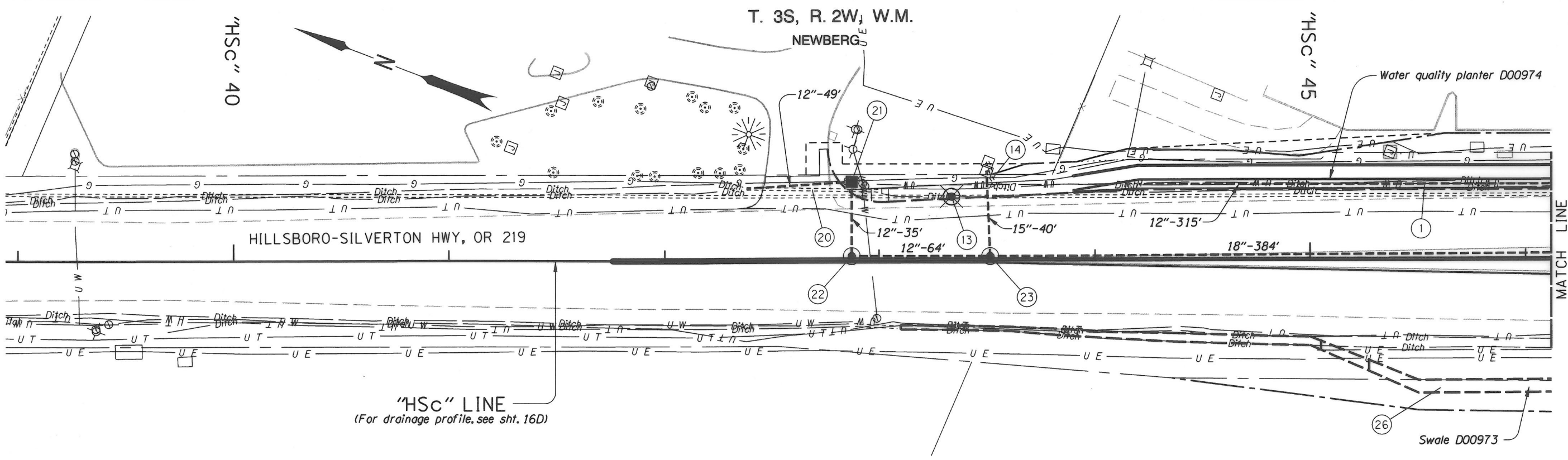
- **Plans and Detail Drawing(s)**



"HSC" LINE
(For drainage profile, see sht. 16D)

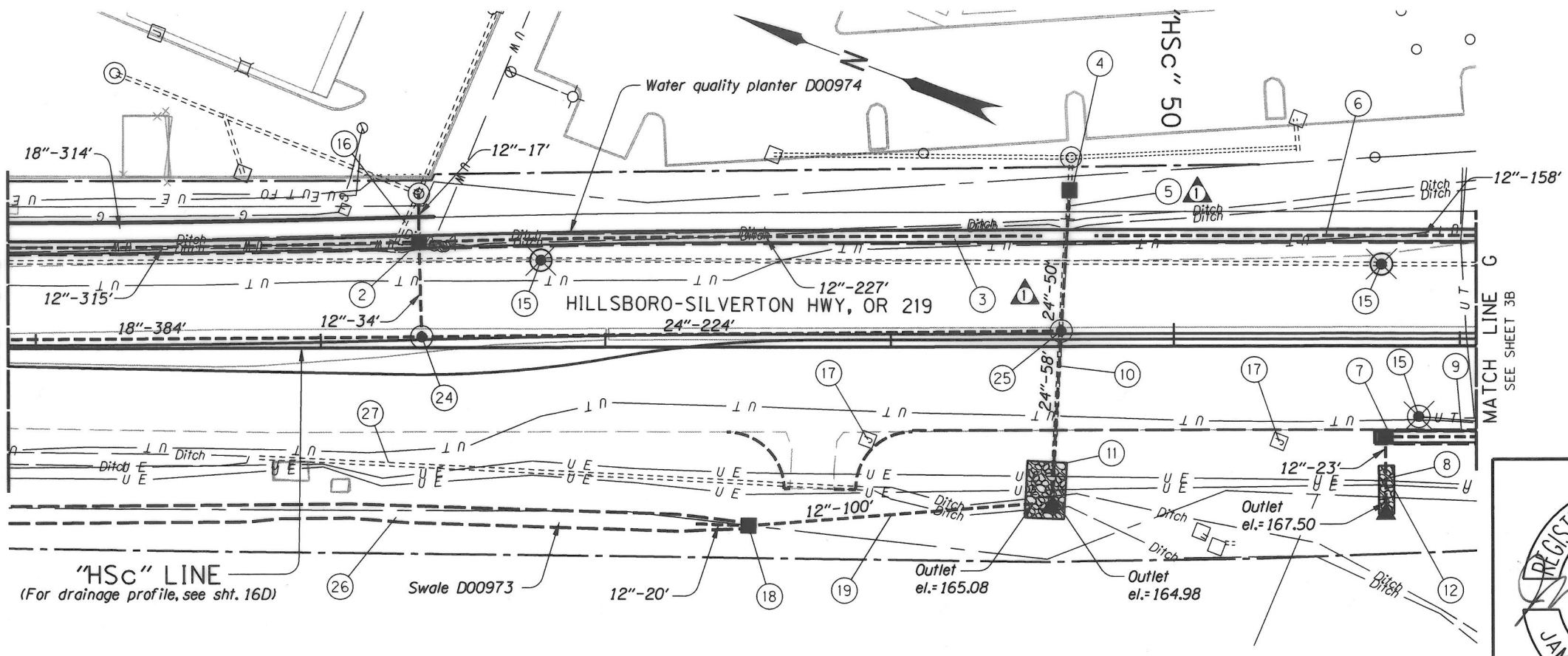

"HSC" LINE
(For drainage profile, see sht. 16D)

No.	DATE	REVISIONS	BY
1	05-17-16	Deleted catch basin and updated stormwater planter design	J.A.P.

OREGON DEPARTMENT OF TRANSPORTATION

Parametrix

OR18: NEWBERG-DUNDEE BYPASS (PHASE 1G) (SPRINGBROOK RD) SEC. HILLSBORO-SILVERTON, PACIFIC HWY WEST, & SALMON RIVER HWYS. YAMHILL COUNTY

Design Team Leader - Rebecca Cushman
Designed By - Ryan Retzlaff
Drafted By - Jim Phillips



EXPIRES: 12/31/16

DRAINAGE & UTILITIES

SHEET NO.
16B

- ① Const. stormwater planter D00974
Inst. 12" drain pipe - 315'
s=0.0049'/ft
I.E. (in)= 168.66
I.E. (out)= 167.11
Inst. cleanout - 3
(For details, see shts. GJ, GJ-2, GJ-3, GJ-4, GJ-11, and GJ-12)
- ② Sta. "HSc" 47+34.53, 37.33' Lt.
Const. catch basin, type 3 (modified)
Inst. 12" storm sew. pipe - 17'
5' depth
Connect to extg. manhole
(For details, see sht. GJ-9)
- ③ Const. stormwater planter D00974
Inst. 12" drain pipe - 227'
s=0.0030'/ft
I.E. (in)= 167.79
I.E. (out)= 167.11
Inst. cleanout - 3
(For details, see shts. GJ, GJ-2, GJ-3, GJ-4, GJ-11 & GJ-12)
- ④ Sta. "HSc" 49+63.29, 55.10' Lt.
Const. type "D" inlet
Connect to extg. storm sew. pipe
- ⑤ Remove pipe - 13'
- ⑥ See sht. 3B-2, note 9
Const. stormwater planter D00974
Inst. 12" drain pipe
Inst. cleanout
- ⑦ Sta. "HSc" 50+73.75, 32.00' Rt.
Const. catch basin, type 3 (modified)
(For details, see sht. GJ-9)
- ⑧ Sta. "HSc" 50+73.75, 32.00' Rt., F.L. El. 168.00 to
Sta. "HSc" 50+73.75, 55.25' Rt., F.L. El. 167.50
Inst. 12" storm sew. pipe - 23'
5' depth
s=0.022'/ft
Const. paved end slope - 26 sq. ft.
- ⑨ See sht. 3B-2, note 27
Const. stormwater planter D00978
Inst. 12" drain pipe
- ⑩ Sta. "HSc" 49+60.19, 5.50' Lt., F.L. El. 165.56 to
Sta. "HSc" 49+56.75, 52.70' Rt., F.L. El. 164.98
Remove pipe - 93'
Inst. 24" storm sew. pipe - 58'
10' depth
s=0.010'/ft.
Const. paved end slope - 44 sq. ft.
Trench resurf. - 14 sq. yd.

- ⑪ Const. 13'x22'x2' loose riprap energy dissipator pad (class 50) - 22 cu. yd.
(For details, see sht. GJ-5)
- ⑫ Const. 5'x17'x2' loose riprap energy dissipator pad (class 50) - 7 cu. yd.
(For details, see sht. GJ-5)
- ⑬ Major adjust manhole
(See drg. no. RD360)
- ⑭ Remove pipe - 8'
- ⑮ Minor adjust manhole - 3
- ⑯ Remove pipe - 20'
- ⑰ Remove junction box - 2
(For details, see signal plans)
(For drg. nos., see sht. 1A)
- ⑱ Sta. "HSc" 48+50.00, 63.00' Rt.
Const. type "D" inlet
Rim elev. = 166.90
I.E. (in) = 165.40
I.E. (out) = 165.40
Inst. 12" drain pipe - 20'
s=0.0060'/ft
- ⑲ Sta. "HSc" 48+50.00, 63.00' Rt., F.L. El. 165.40 to
Sta. "HSc" 49+50.00, 55.40' Rt., F.L. El. 165.08
Inst. 12" storm sew. pipe - 100'
5' depth
s=0.0032'/ft
- ⑳ Remove pipe - 62'
Trench resurf. - 14 sq. yd.
- ㉑ Sta. "HSc" 42+87.30, 36.62' Lt.
Const. type "D" inlet
Rim elev. = 173.32
I.E. (in) = 170.55
I.E. (out) = 170.45
Inst. 12" storm sew. pipe - 49'
5' depth
- ㉒ Sta. "HSc" 42+87.30, 2.00' Lt.
Const. manhole, 48" dia. with tamperproof cover
Inst. 12" storm sew. pipe - 35'
5' depth
Trench resurf. - 7 sq. yd.
- ㉓ Sta. "HSc" 43+51.34, 2.00' Lt.
Const. manhole, 48" dia. with tamperproof cover
Inst. 12" storm sew. pipe - 64'
5' depth
Inst. 15" storm sew. pipe - 40'
5' depth
Connect to extg. ditch inlet
Trench resurf. - 30 sq. yd.

- ㉔ Sta. "HSc" 47+35.36, 3.84' Lt.
Const. manhole, 48" dia. with tamperproof cover
Inst. 12" storm sew. pipe - 34'
5' depth
Inst. 18" storm sew. pipe - 384'
10' depth
Trench resurf. - 158 sq. yd.
- ㉕ Sta. "HSc" 49+60.19, 5.50' Lt.
Const. manhole, 60" dia. with tamperproof cover
Inst. 24" storm sew. pipe - 50'
10' depth
Inst. 24" storm sew. pipe - 224'
10' depth
Trench resurf. - 111 sq. yd.
- ㉖ Const. water quality biofiltration swale D00973
width varies
slope slopes = 1:4
Inst. field facility markers - 4
(For details, see shts. GJ-4 and GJ-12)
- ㉗ Remove pipe - 214'

No.	DATE	REVISIONS	BY
①	05-17-16	Deleted catch basin and updated stormwater planter design	J.A.P.

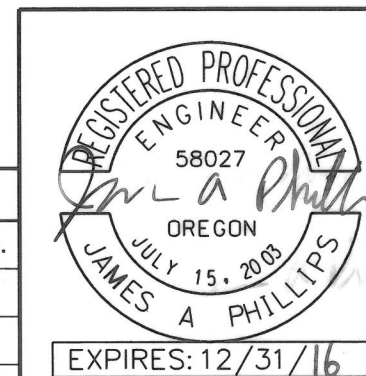

OREGON DEPARTMENT OF TRANSPORTATION

Parametrix

OR18: NEWBERG-DUNDEE BYPASS (PHASE 1G) (SPRINGBROOK RD) SEC.
HILLSBORO-SILVERTON, PACIFIC HWY WEST, & SALMON RIVER HWYS.
YAMHILL COUNTY

Design Team Leader - Rebecca Cushman
Designed By - Ryan Retzlaff
Drafted By - Jim Phillips

DRAINAGE NOTES

SHEET NO. 16B-2

"HSc" LINE, LEFT

49V-017

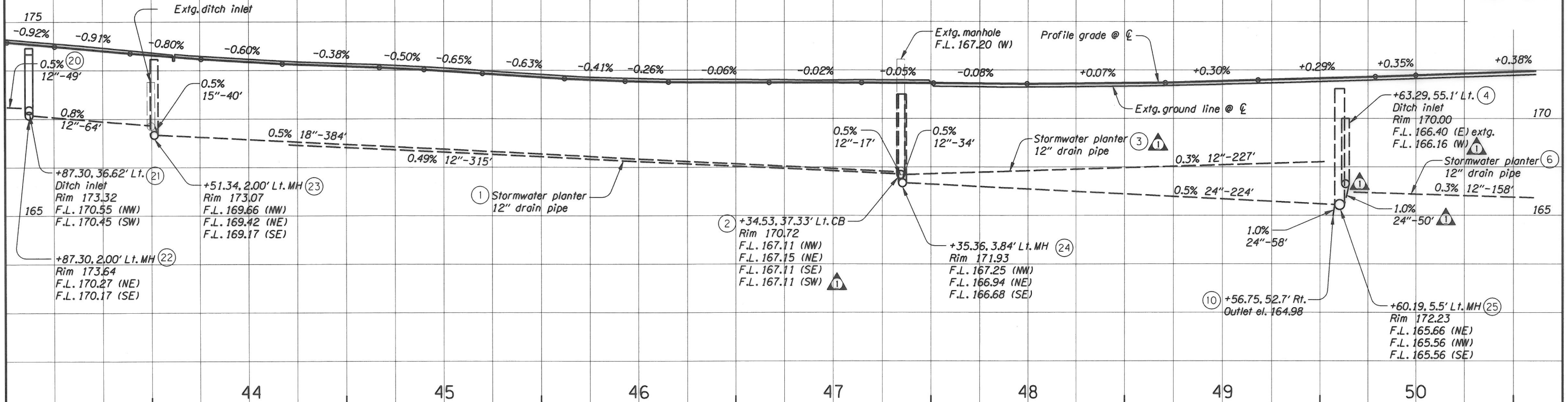

"HSc" LINE, RIGHT

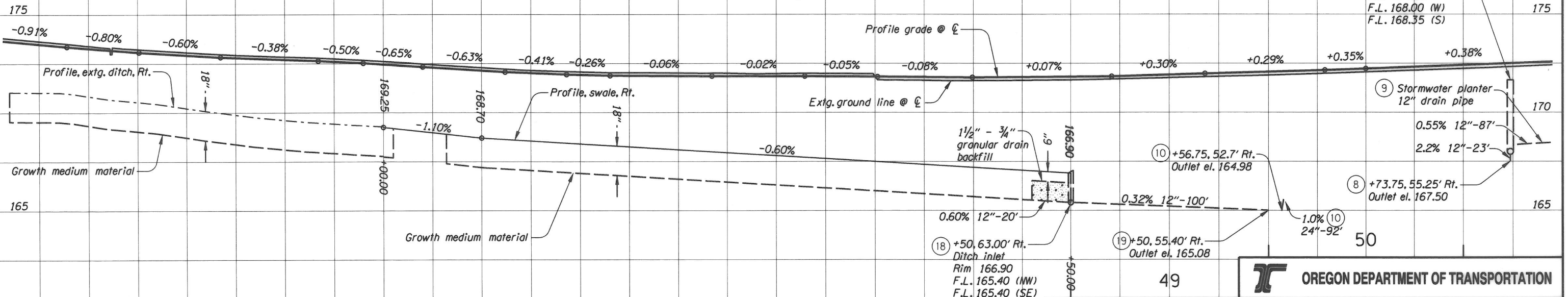

No.	DATE	REVISIONS	BY
1	05-17-16	Deleted catch basin and updated stormwater planter profile	J.A.P.



OREGON DEPARTMENT OF TRANSPORTATION

Parametrix

OR18: NEWBERG-DUNDEE BYPASS (PHASE 1G) (SPRINGBROOK RD) SEC. HILLSBORO-SILVERTON, PACIFIC HWY WEST, & SALMON RIVER HWYS. YAMHILL COUNTY

Design Team Leader - Rebecca Cushman
Designed By - Ryan Retzlaff
Drafted By - Jim Phillips

DRAINAGE PROFILE

SHEET NO. 16D

Sec. 21, T. 3S, R. 2W, W.M.
NEWBERG

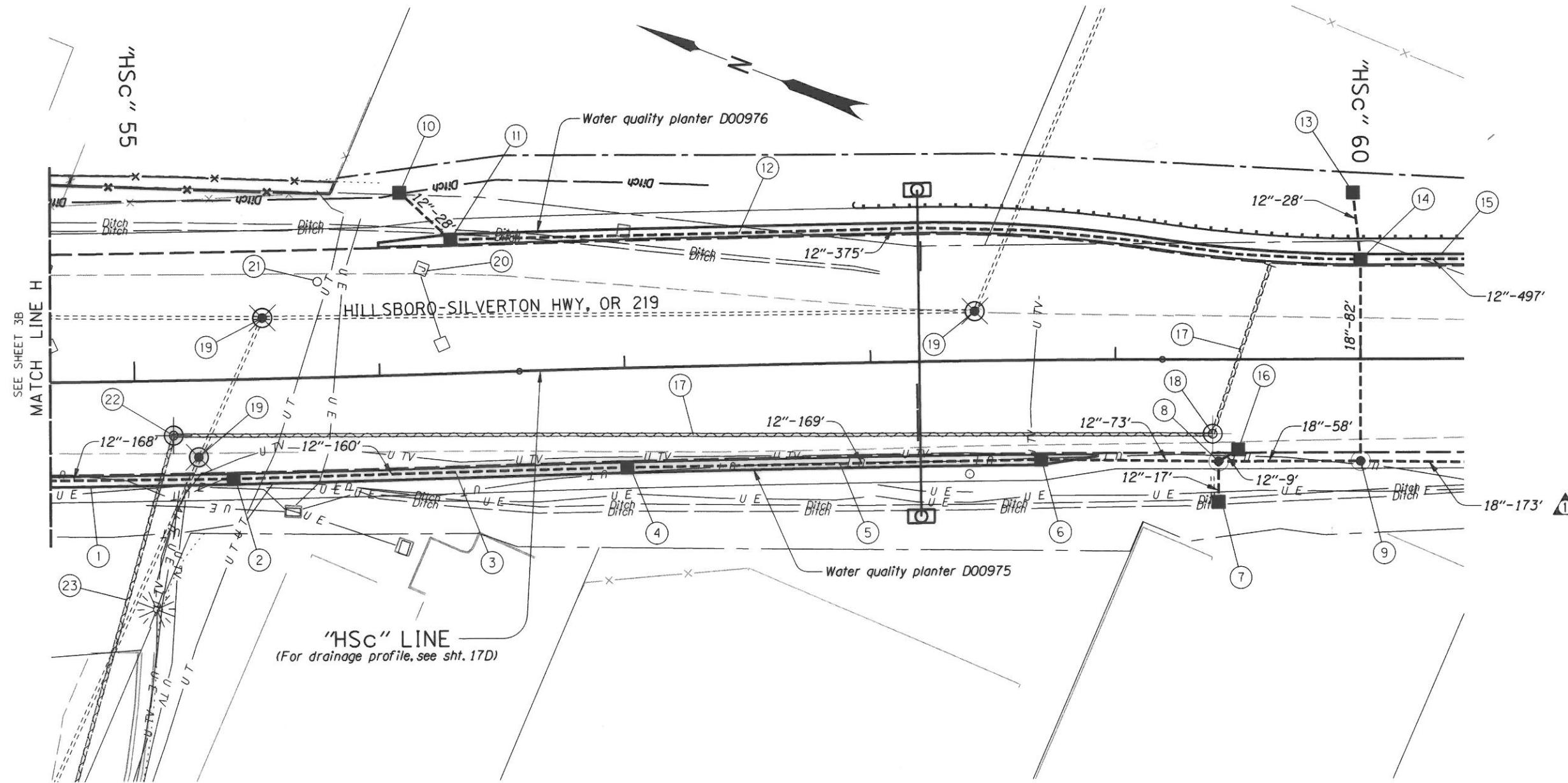

SEE SHEET 3B
MATCH LINE H

"HSc" LINE
(For drainage profile, see sht. 17D)

Plug and abandon extg. pipe shown thus:

No.	DATE	REVISIONS	BY
1	03-31-16	Updated Stormwater design & Revised pipes	J.A.P.



Parametrix
 OR18: NEWBERG-DUNDEE BYPASS (PHASE 1G)
 (SPRINGBROOK RD) SEC.
 HILLSBORO-SILVERTON, PACIFIC HWY WEST, &
 SALMON RIVER HWYS,
 YAMHILL COUNTY
 Design Team Leader - Rebecca Cushman
 Designed By - Ryan Retzlaff
 Drafted By - Jim Phillips

DRAINAGE & UTILITIES SHEET NO. 17B

- ① See sht. 3B-2, note 7
Const. stormwater planter D00975
Inst. 12" drain pipe
Inst. cleanout
(For details, see shts. GJ, GJ-2, GJ-3, GJ-4, GJ-11 & GJ-12)
- ② Sta. "HSc" 55+40.00, 40.50' Rt.
Const. catch basin, type 3 (modified)
(For details, see sht. GJ-9)
- ③ Const. stormwater planter D00975
Inst. 12" drain pipe - 160'
s=0.0030'/ft
I.E. (in)= 168.49
I.E. (out)= 168.00
Inst. cleanout - 1
(For details, see shts. GJ, GJ-2, GJ-3, GJ-4, GJ-11 & GJ-12)
- ④ Sta. "HSc" 57+00.00, 40.50' Rt.
Const. catch basin, type 3 (modified)
(For details, see sht. GJ-9)
- ⑤ Const. stormwater planter D00975
Inst. 12" drain pipe - 169'
s=0.0030'/ft
I.E. (in)= 168.00
I.E. (out)= 167.50
Inst. cleanout - 1
(For details, see shts. GJ, GJ-2, GJ-3, GJ-4, GJ-11 & GJ-12)
- ⑥ Sta. "HSc" 58+69.50, 40.50' Rt.
Const. catch basin, type 3 (modified)
(For details, see sht. GJ-9)
- ⑦ Sta. "HSc" 59+42.00, 58.00' Rt.
Const. type "D" inlet
Rim elev.= 168.03
I.E. (out)= 167.83
- ⑧ Sta. "HSc" 59+42.00, 41.50' Rt.
Const. manhole, 48" dia. with tamperproof cover
Inst. 12" storm sew. pipe - 73'
10' depth
Inst. 12" storm sew. pipe - 17'
10' depth
Inst. 12" storm sew. pipe - 9'
10' depth
- ⑨ Sta. "HSc" 60+00.00, 41.50' Rt.
Const. manhole, 48" dia. with tamperproof cover
Inst. 18" storm sew. pipe - 58'
10' depth
Inst. 18" storm sew. pipe - 82'
10' depth
Trench resurf. - 18 sq. yd.
- ⑩ Sta. "HSc" 56+10.00, 74.30' Lt.
Const. type "D" inlet
Rim elev.= 168.40
I.E. (out)= 168.37
- ⑪ Sta. "HSc" 54+30.00, 54.50' Lt.
Const. catch basin, type 3 (modified)
Inst. 12" storm sew. pipe - 28'
5' depth
(For details, see sht. GJ-9)
- ⑫ Const. stormwater planter D00976
Inst. 12" drain pipe - 375'
s=0.0030'/ft
I.E. (in)= 168.23
I.E. (out)= 167.10
Inst. cleanout - 3
Inst. field facility markers - 4
(For details, see shts. GJ, GJ-2, GJ-3, GJ-4, GJ-11 & GJ-12)
- ⑬ Sta. "HSc" 59+97.00, 67.85' Lt.
Const. type "D" inlet
Rim elev.= 168.60
I.E. (out)= 167.34
- ⑭ Sta. "HSc" 60+00.00, 40.50' Lt.
Const. catch basin, type 3 (modified)
Inst. 12" storm sew. pipe - 28'
10' depth
(For details, see sht. GJ-9)
- ⑮ Const. stormwater planter D00976
Inst. 12" drain pipe - 497'
s=0.0030'/ft
I.E. (in)= 169.55
I.E. (out)= 168.06
Inst. cleanout - 5
(For details, see shts. GJ, GJ-2, GJ-3, GJ-4, GJ-11 & GJ-12)
- ⑯ Sta. "HSc" 59+50.00, 36.67' Rt.
Const. type "G-2" inlet
- ⑰ Plug and abandon pipe - 2
12" storm - 425'
18" storm - 75'
- ⑱ Remove manhole
- ⑲ Minor adjust manhole - 3
- ⑳ Remove junction box
(For details, see signal plans)
(For drg. nos., see sht. 1A)
- ㉑ Adjust valve box
- ㉒ See sht. 3B, note 34
Remove manhole
- ㉓ See sht. 3B, note 31
Abandon pipe



No.	DATE	REVISIONS	BY
①	01-28-16	Added pipe sizes and lengths	J.A.P.
②	03-31-16	Modifeid I.E. elevations in note	J.A.P.



OREGON DEPARTMENT OF TRANSPORTATION

Parametrix

**OR18: NEWBERG-DUNDEE BYPASS (PHASE 1G)
(SPRINGBROOK RD) SEC.
HILLSBORO-SILVERTON, PACIFIC HWY WEST, &
SALMON RIVER HWYS,
YAMHILL COUNTY**

Design Team Leader - Rebecca Cushman
Designed By - Ryan Retzlaff
Drafted By - Jim Phillips

DRAINAGE NOTES

SHEET NO. **17B-2**

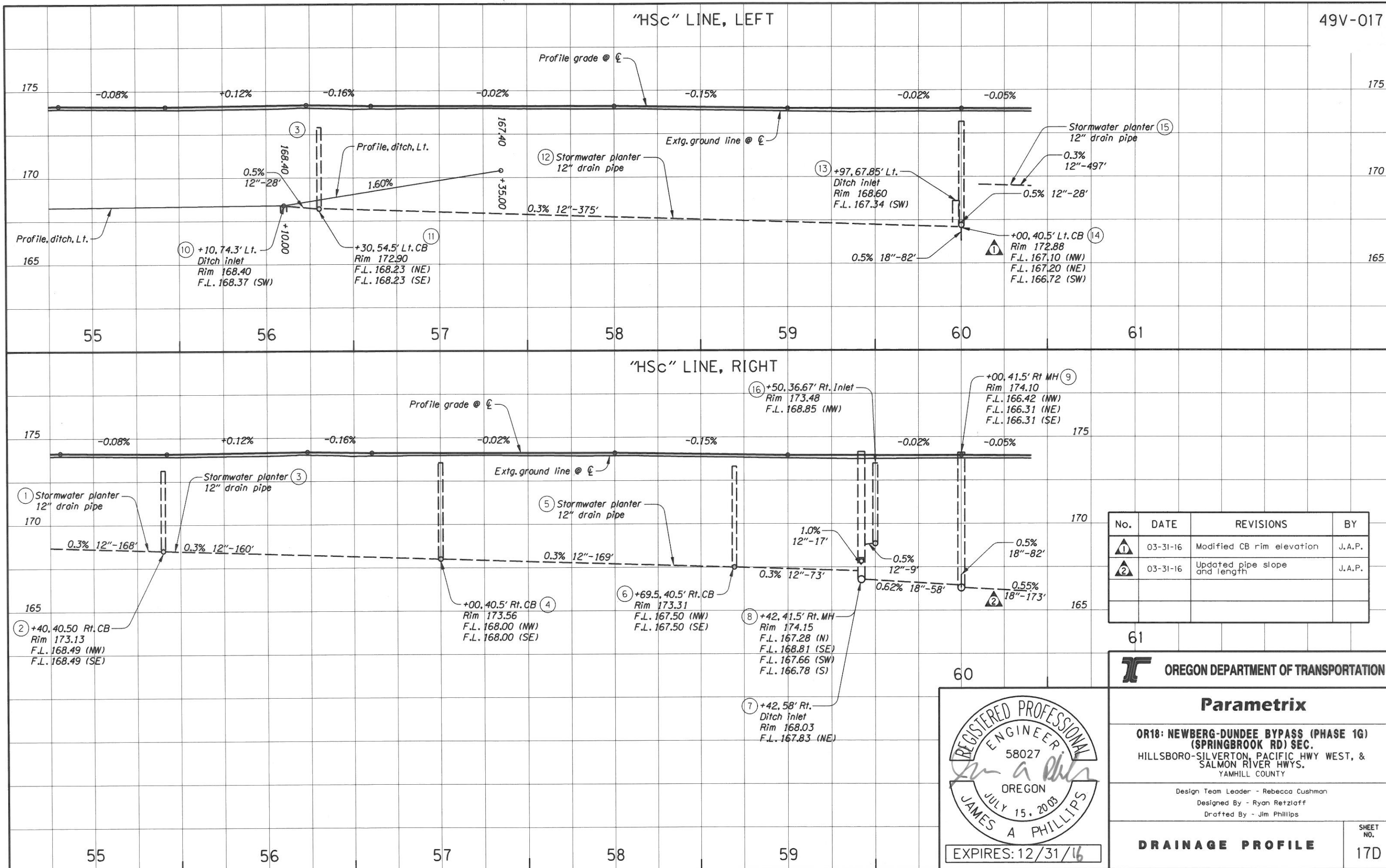

No.	DATE	REVISIONS	BY
1	03-31-16	Modified CB rim elevation	J.A.P.
2	03-31-16	Updated pipe slope and length	J.A.P.

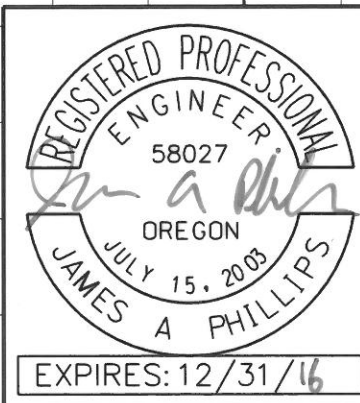

OREGON DEPARTMENT OF TRANSPORTATION

Parametrix

OR18: NEWBERG-DUNDEE BYPASS (PHASE 1G) (SPRINGBROOK RD) SEC. HILLSBORO-SILVERTON, PACIFIC HWY WEST, & SALMON RIVER HWYS. YAMHILL COUNTY

Design Team Leader - Rebecca Cushman
Designed By - Ryan Retzlaff
Drafted By - Jim Phillips

DRAINAGE PROFILE

SHEET NO. 17D

Sec. 21, T. 3S, R. 2W, W.M.
NEWBERG

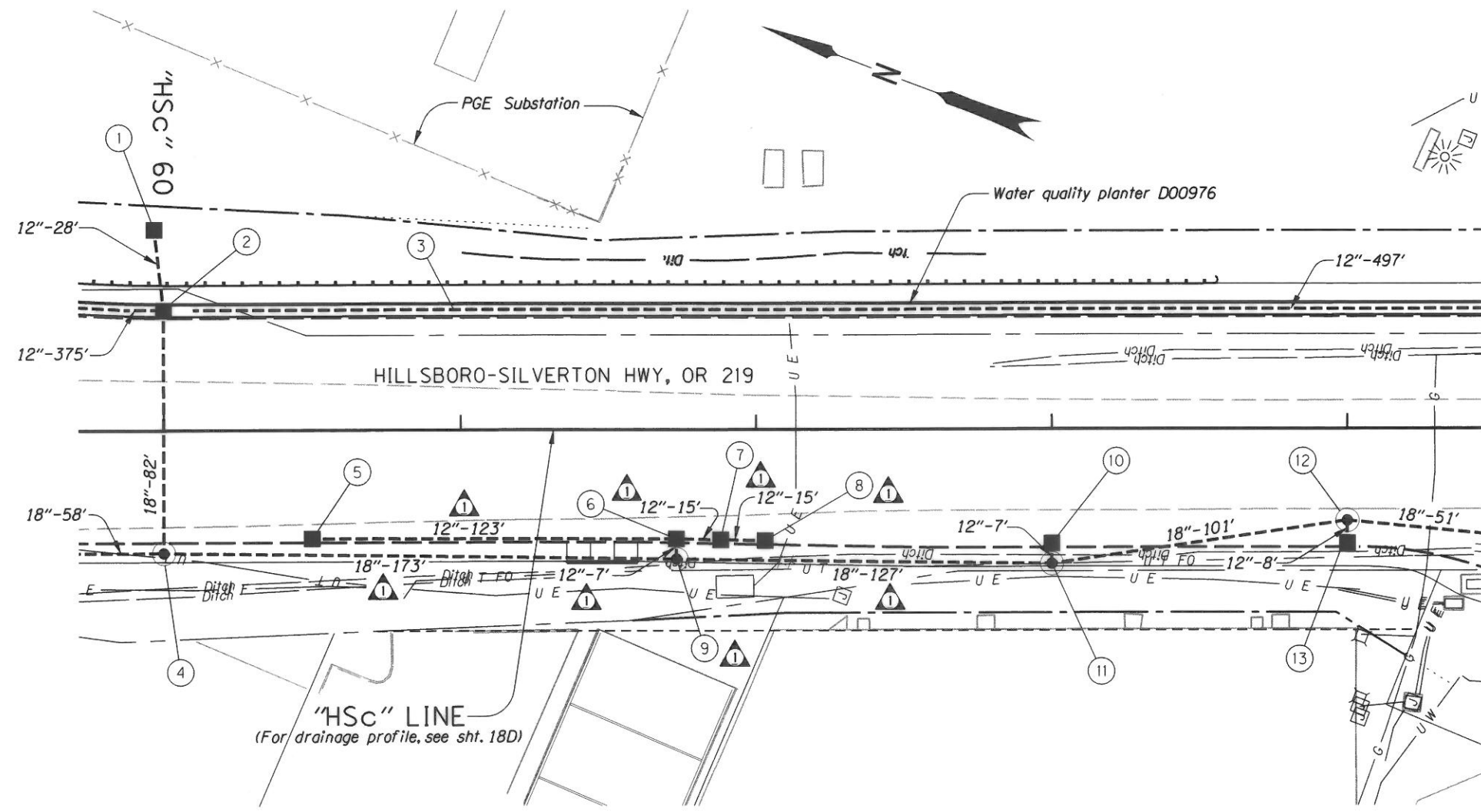

No.	DATE	REVISIONS	BY
1	03-31-16	Updated Stormwater design & Revised pipes & structures	J.A.P.



OREGON DEPARTMENT OF TRANSPORTATION

Parametrix

**OR18: NEWBERG-DUNDEE BYPASS (PHASE 1G)
(SPRINGBROOK RD) SEC.
HILLSBORO-SILVERTON, PACIFIC HWY WEST, &
SALMON RIVER HWYS,
YAMHILL COUNTY**

Design Team Leader - Rebecca Cushman
Designed By - Ryan Retzlaff
Drafted By - Jim Phillips

DRAINAGE & UTILITIES

SHEET NO.
18B

- ① See sht. 17B-2, note 13
Const. type "D" inlet
- ② See sht. 17B-2, note 14
Const. catch basin, type 3 (modified)
Inst. 12" storm sew. pipe
10' depth
(For details, see sht. GJ-9)
- ③ See sht. 17B-2, note 15
Const. stormwater planter D00976
Inst. 12" drain pipe
Inst. cleanout
- ④ See sht. 17B-2, note 9
Const. manhole, 48" dia. with tamperproof cover
Inst. 18" storm sew. pipe
10' depth
Inst. 18" storm sew. pipe
10' depth
Trench resurf.
- ⑤ Sta. "HSc" 60+50.00, 36.67' Rt.
Const. type "G-2" inlet
- ① ⑥ Sta. "HSc" 61+73.00, 36.93' Rt.
Const. type "G-2" inlet
Inst. 12" storm sew. pipe - 123'
10' depth
Inst. 12" storm sew. pipe - 15'
10' depth
- ① ⑦ Sta. "HSc" 61+88.00, 37.23' Rt.
Const. type "G-2" inlet
Inst. 12" storm sew. pipe - 15'
10' depth
- ① ⑧ Sta. "HSc" 62+03.00, 37.53' Rt.
Const. type "G-2" inlet
- ① ⑨ Sta. "HSc" 61+73.00, 43.75' Rt.
Const. manhole, 48" dia. with tamperproof cover
Inst. 12" storm sew. pipe - 7'
10' depth
Inst. 18" storm sew. pipe - 173'
10' depth
- ⑩ Sta. "HSc" 63+00.00, 38.67' Rt.
Const. type "G-2" inlet
- ⑪ Sta. "HSc" 63+00.00, 45.50' Rt.
Const. manhole, 48" dia. with tamperproof cover
Inst. 12" storm sew. pipe - 7'
5' depth
Inst. 18" storm sew. pipe - 90'
10' depth
- ⑫ Sta. "HSc" 64+00.00, 31.00' Rt.
Const. manhole, 48" dia. with tamperproof cover
Minor adjust manhole
Inst. 12" storm sew. pipe - 8'
5' depth
Inst. 18" storm sew. pipe - 101'
20' depth
- ⑬ Sta. "HSc" 64+00.00, 38.70' Rt.
Const. type "G-2" inlet

No.	DATE	REVISIONS	BY
①	03-31-16	Updated Stormwater design & Revised pipe & structure notes	J.A.P.

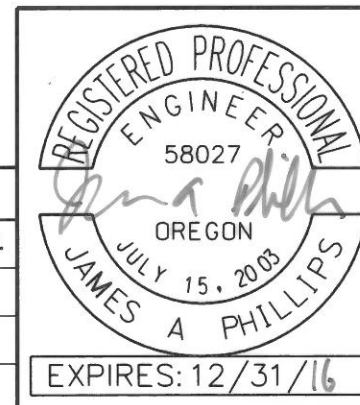

OREGON DEPARTMENT OF TRANSPORTATION	
Parametrix	
OR18: NEWBERG-DUNDEE BYPASS (PHASE 1G) (SPRINGBROOK RD) SEC. HILLSBORO-SILVERTON, PACIFIC HWY WEST, & SALMON RIVER HWYS. YAMHILL COUNTY	
Design Team Leader - Rebecca Cushman Designed By - Ryan Retzlaff Drafted By - Jim Phillips	
DRAINAGE NOTES	SHEET NO. 18B-2

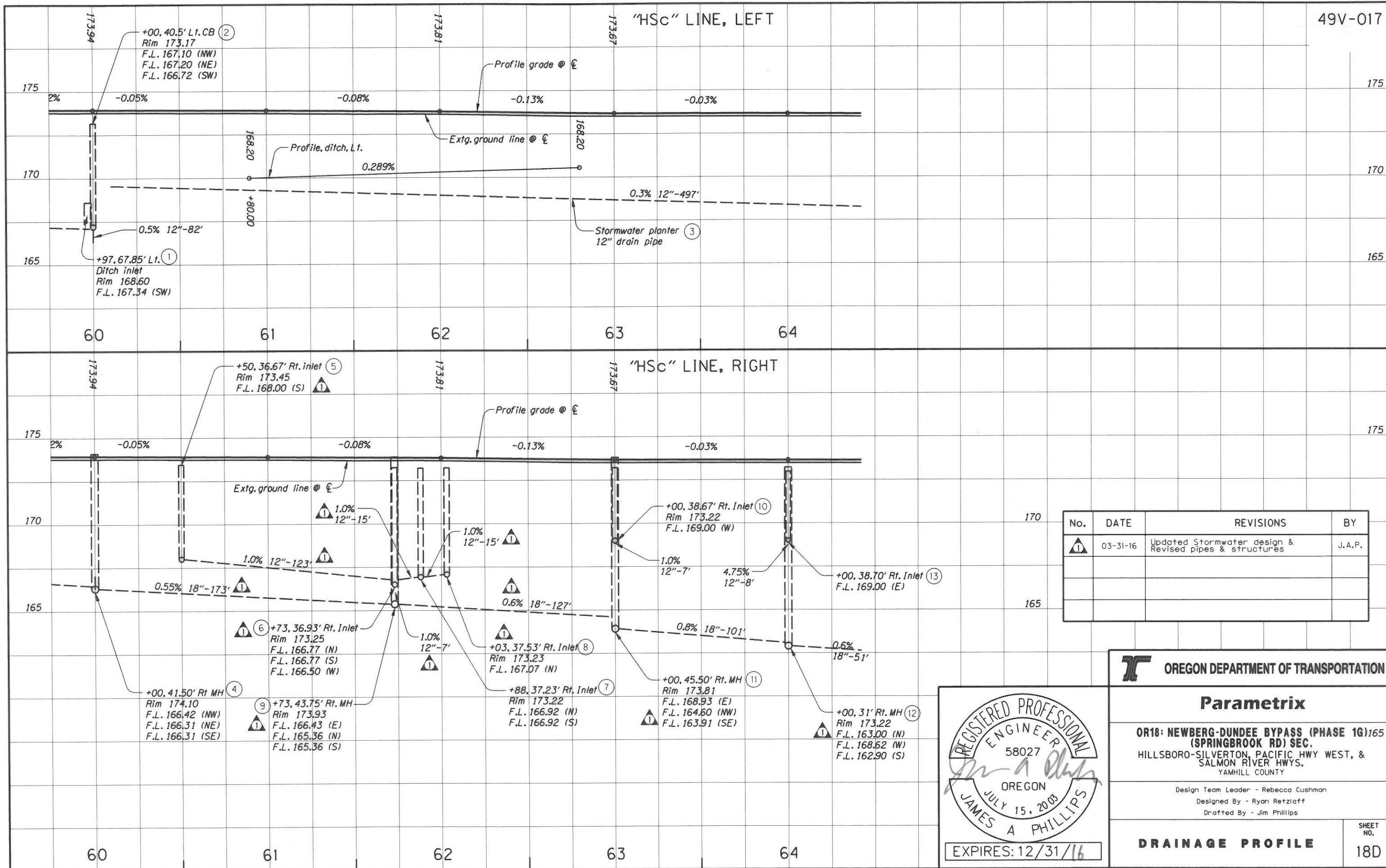

No.	DATE	REVISIONS	BY
(1)	03-31-16	Updated Stormwater design & Revised pipes & structures	J.A.P.

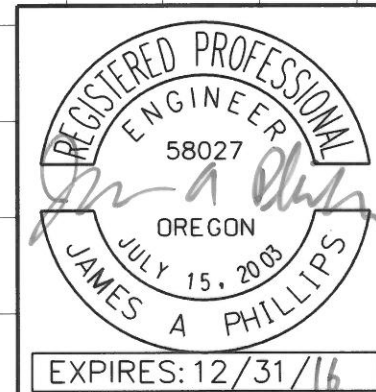

OREGON DEPARTMENT OF TRANSPORTATION

Parametrix

OR18: NEWBERG-DUNDEE BYPASS (PHASE 1G) 165 (SPRINGBROOK RD) SEC. HILLSBORO-SILVERTON, PACIFIC HWY WEST, & SALMON RIVER HWYS. YAMHILL COUNTY

Design Team Leader - Rebecca Cushman
Designed By - Ryan Retzlaff
Drafted By - Jim Phillips

DRAINAGE PROFILE

SHEET NO. 18D

Sec. 21, T. 3S, R. 2W, W.M.

NEWBERG

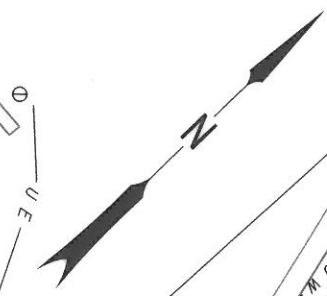
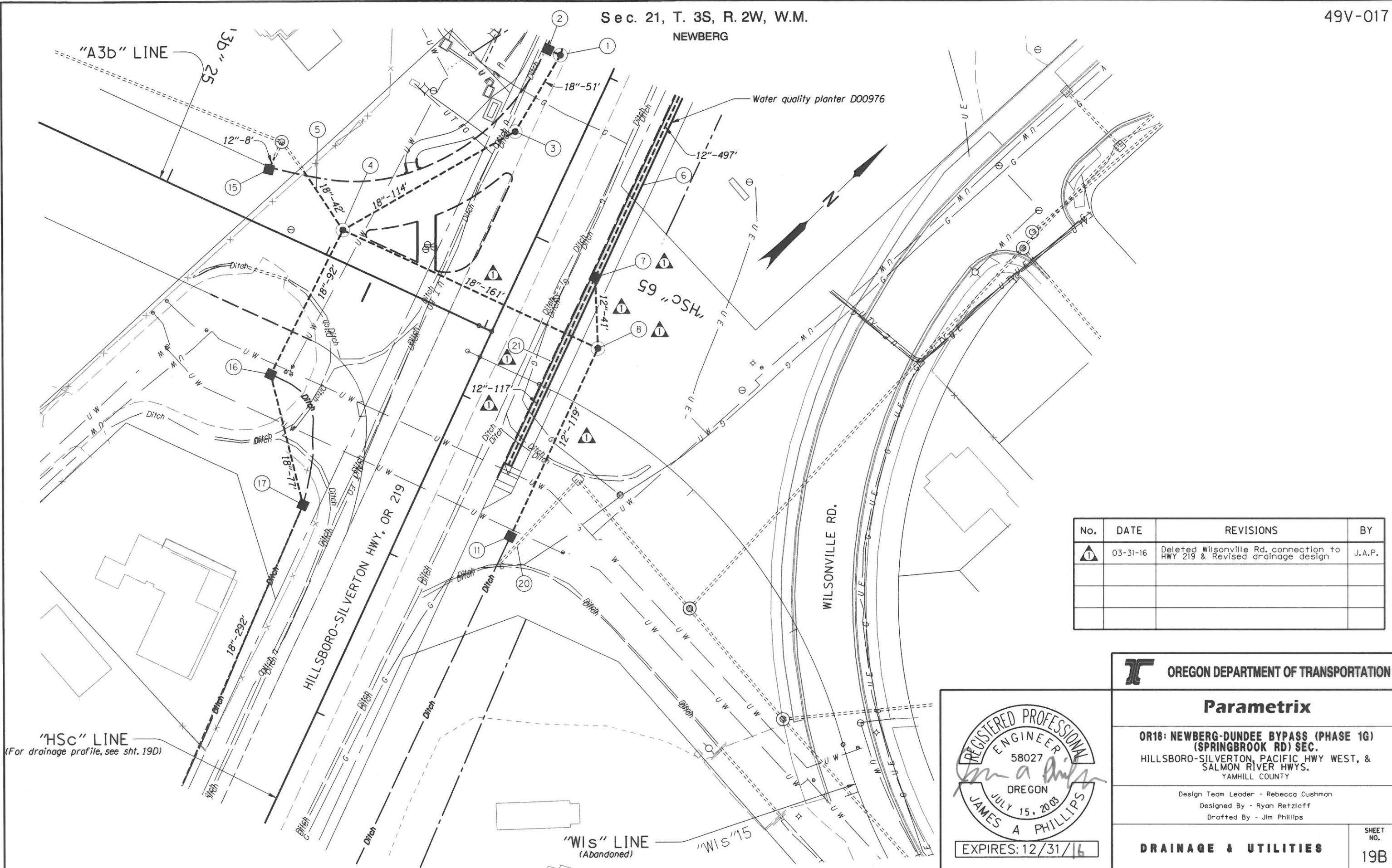

No.	DATE	REVISIONS	BY
1	03-31-16	Deleted Wilsonville Rd. connection to HWY 219 & Revised drainage design	J.A.P.

OREGON DEPARTMENT OF TRANSPORTATION

Parametrix

**OR18: NEWBERG-DUNDEE BYPASS (PHASE 1G)
(SPRINGBROOK RD) SEC.
HILLSBORO-SILVERTON, PACIFIC HWY WEST, &
SALMON RIVER HWYS.
YAMHILL COUNTY**

Design Team Leader - Rebecca Cushman
Designed By - Ryan Retzlaff
Drafted By - Jim Phillips

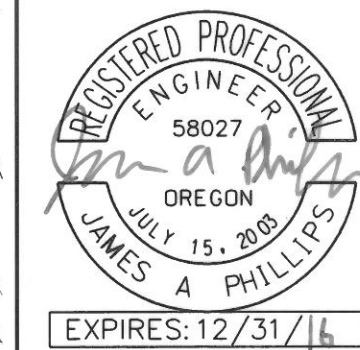

DRAINAGE & UTILITIES

SHEET NO.
19B

- ① See sht. 18B-2, note 12
Const. manhole, 48" dia. with tamperproof cover
Minor adjust manhole
Inst. 12" storm sew. pipe
5' depth
Inst. 18" storm sew. pipe
20' depth
- ② See sht. 18B-2, note 13
Const. type "G-2" inlet
- ③ Sta. "HSc" 64+50.50, 36.00' Rt.
Const. manhole, 48" dia. with tamperproof cover
Minor adjust manhole
Inst. 18" storm sewer pipe - 51'
20' depth
- ④ Sta. "A3b" 26+02.70, 16.75' Lt.
Const. manhole, 72" dia. with tamperproof cover
Minor adjust manhole
Inst. 18" storm sew. pipe - 161'
10' depth
Inst. 18" storm sew. pipe - 114'
20' depth
Inst. 18" storm sew. pipe - 92'
10' depth
Trench resurf. - 13 sq. yd.
- ⑤ Inst. 18" storm sew. pipe - 42'
10' depth
Connect to extg. storm sew. pipe stub
- ⑥ See sht. 17B-2, note 15
Const. stormwater planter D00976
Inst. 12" drain pipe
Inst. cleanout
- ⑦ Sta. "HSc" 65+07.00, 40.50' Lt.
Const. catch basin, type 3 (modified)
(For details, see sht. GJ-9)
- ⑧ Sta. "HSc" 65+43.25, 59.00' Lt.
Const. manhole, 48" dia. with tamperproof cover
Inst. 12" storm sew. pipe - 41'
10' depth
Inst. 12" storm sew. pipe - 119'
10' depth
- ⑨ Note deleted
- ⑩ Note deleted
- ⑪ Sta. "HSc" 66+62.00, 59.00' Lt.
Const. type "D" inlet
- ⑫ Note deleted
- ⑬ Note deleted
- ⑭ Note deleted
- ⑮ Sta. "A3b" 25+50.00, 30.70' Lt.
Const. type "G-2" inlet
Inst. 12" storm sew. pipe - 8'
5' depth
Connect to extg. storm sew. pipe stub
- ⑯ Sta. "HSc" 66+35.34, 104.59' Rt.
Const. type "D" inlet
Inst. 18" storm sew. pipe - 77'
5' depth
- ⑰ Sta. "HSc" 66+95.46, 56.58' Rt.
Const. type "D" inlet
Inst. 18" storm sew. pipe - 292'
5' depth
- ⑱ Note deleted
- ⑲ Note deleted
- ⑳ Remove pipe - 67'
- ㉑ Const. stormwater planter
Inst. 12" drain pipe - 117'
s=0.003'/ft.
I.E. (in)= 168.95
I.E. (out)= 168.62
Inst. cleanout - 1
(For details, see shts. GJ, GJ-2, GJ-3, GJ-4, & GJ-11)

No.	DATE	REVISIONS	BY
①	03-31-16	Deleted Wilsonville Rd. connection to HWY 219 & Modified notes	J.A.P.
②	03-31-16	Deleted Wilsonville Rd. connection to HWY 219 & Deleted notes	J.A.P.

OREGON DEPARTMENT OF TRANSPORTATION

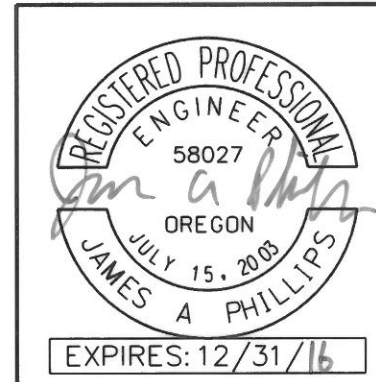

Parametrix

OR18: NEWBERG-DUNDEE BYPASS (PHASE 1G) (SPRINGBROOK RD) SEC.
HILLSBORO-SILVERTON, PACIFIC HWY WEST, & SALMON RIVER HWYS.
YAMHILL COUNTY

Design Team Leader - Rebecca Cushman
Designed By - Ryan Retzlaff
Drafted By - Jim Phillips

DRAINAGE NOTES

SHEET NO. 19B-2

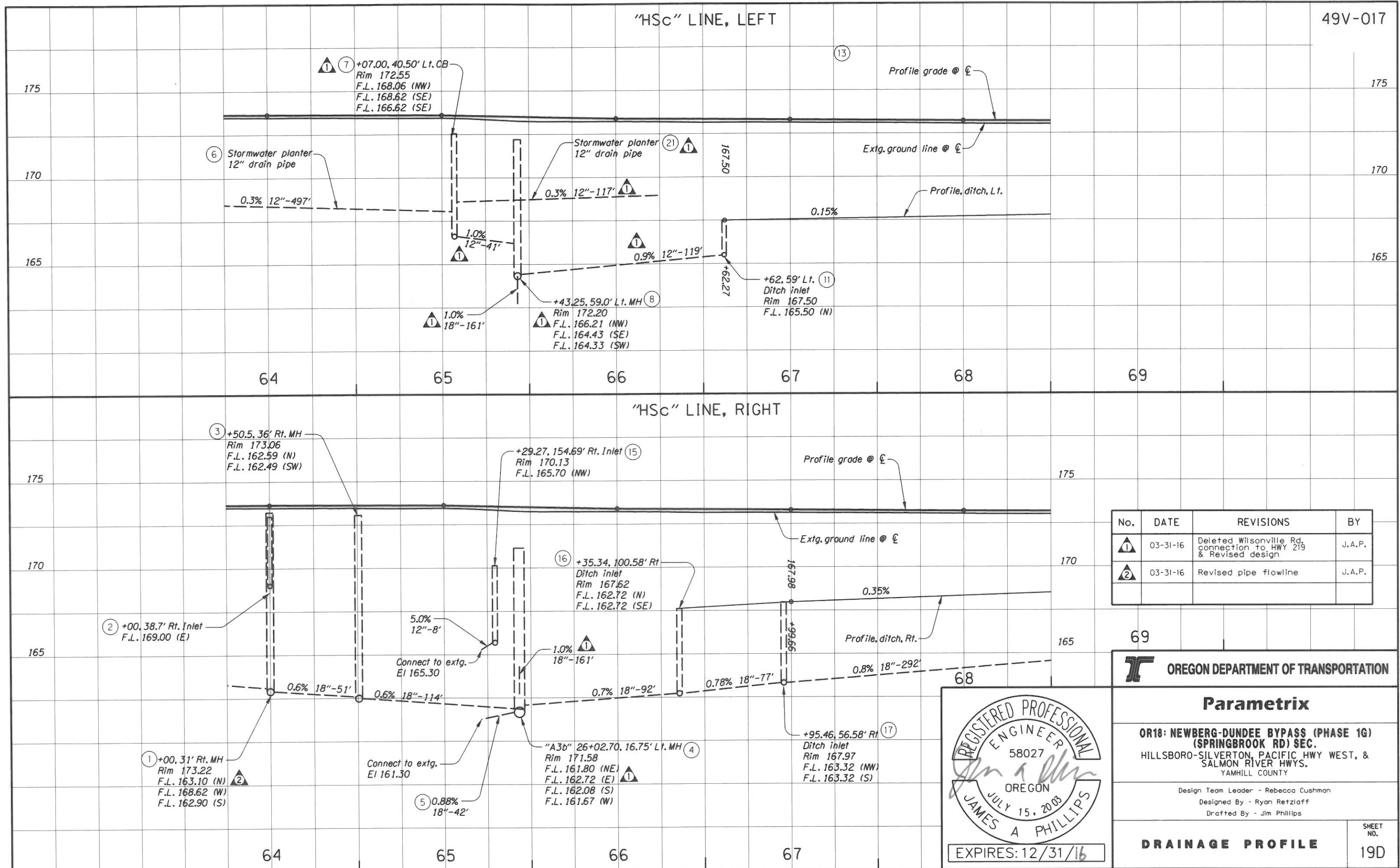

No.	DATE	REVISIONS	BY
1	03-31-16	Deleted Wilsonville Rd. connection to HWY 219 & Revised design	J.A.P.
2	03-31-16	Revised pipe flowline	J.A.P.

OREGON DEPARTMENT OF TRANSPORTATION

Parametrix

OR18: NEWBERG-DUNDEE BYPASS (PHASE 1G) (SPRINGBROOK RD) SEC. HILLSBORO-SILVERTON, PACIFIC HWY WEST, & SALMON RIVER HWYS. YAMHILL COUNTY

Design Team Leader - Rebecca Cushman
 Designed By - Ryan Retzlaff
 Drafted By - Jim Phillips

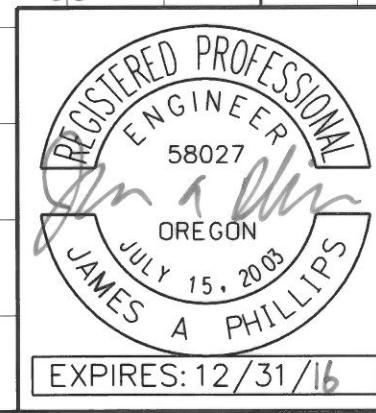

DRAINAGE PROFILE SHEET NO. 19D

"Wis" LINE (Abandoned) 

49V-017

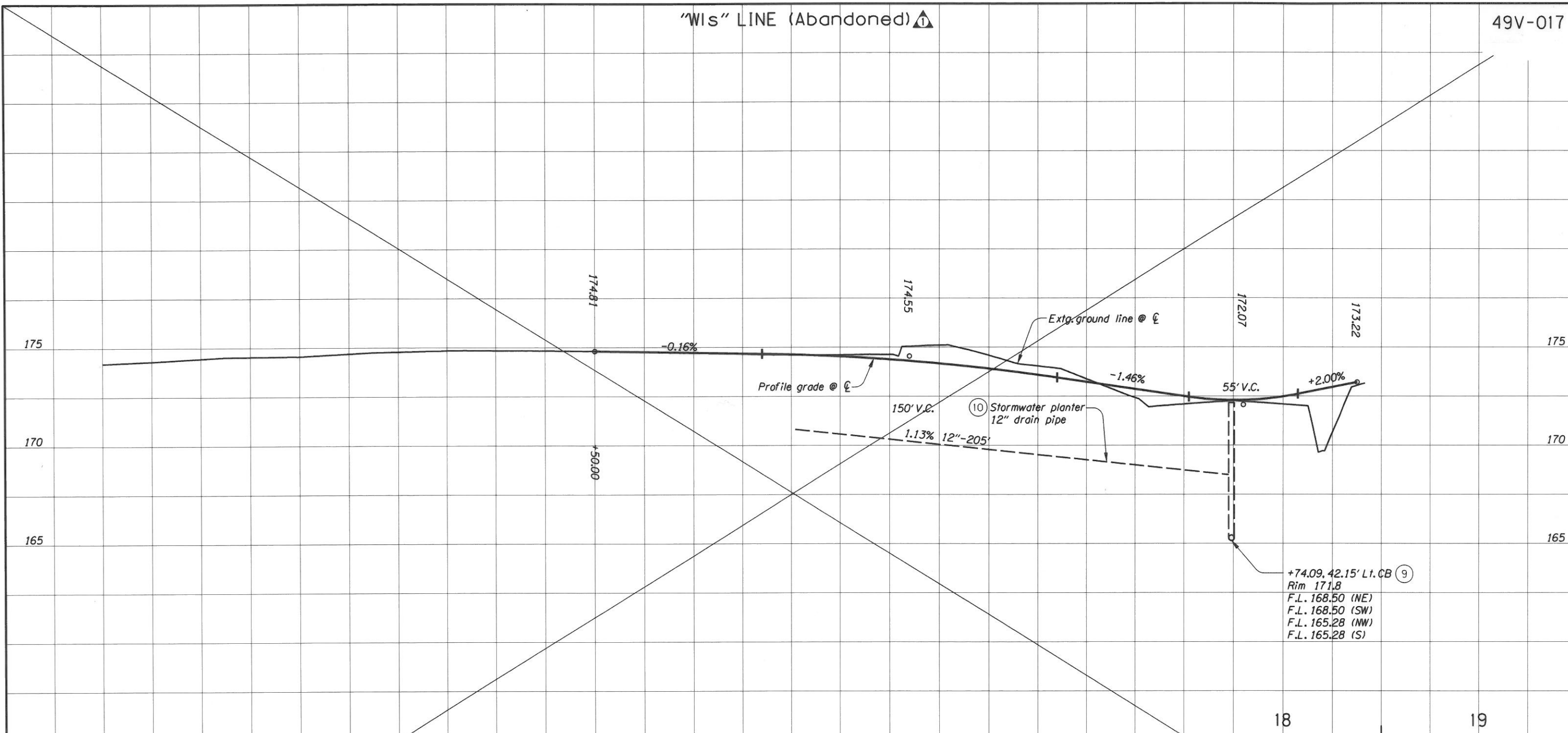

No.	DATE	REVISIONS	BY
	03-31-16	Deleted Wilsonville Rd. connection to Hwy 219, & abandoned this work	J.A.P.

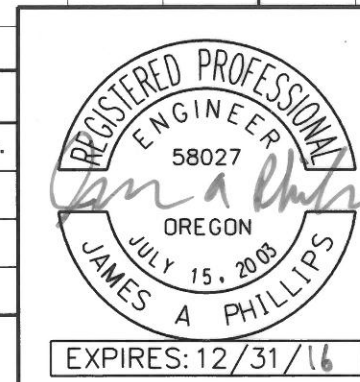

 OREGON DEPARTMENT OF TRANSPORTATION

Parametrix

OR18: NEWBERG-DUNDEE BYPASS (PHASE 1G) (SPRINGBROOK RD) SEC. HILLSBORO-SILVERTON, PACIFIC HWY WEST, & SALMON RIVER HWYS. YAMHILL COUNTY

Design Team Leader - Rebecca Cushman
 Designed By - Ryan Retzlaff
 Drafted By - Jim Phillips

DRAINAGE PROFILE SHEET NO. 19F

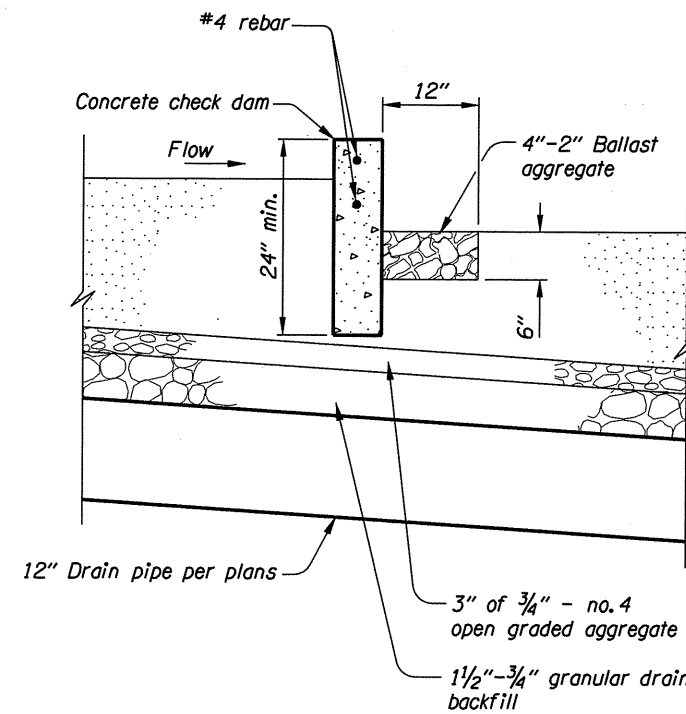
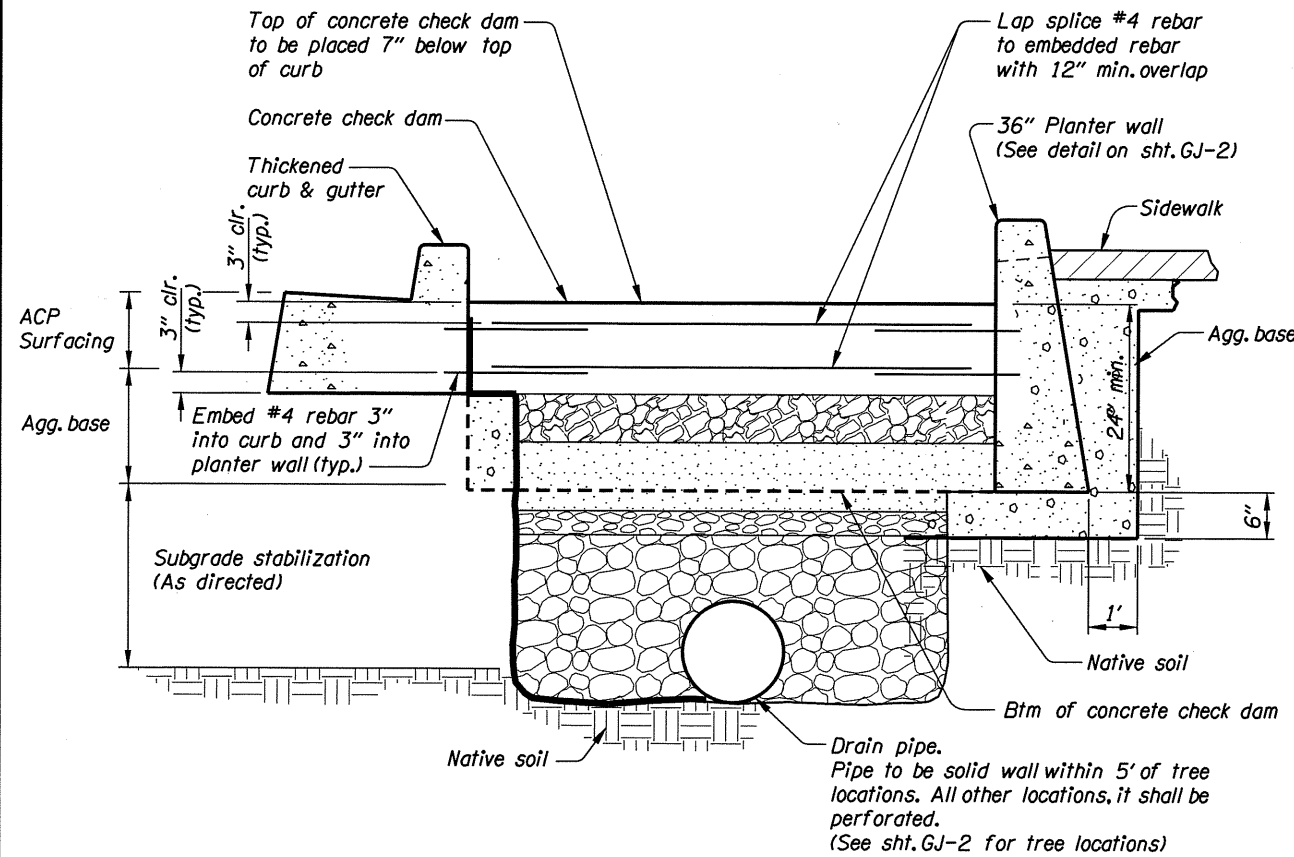
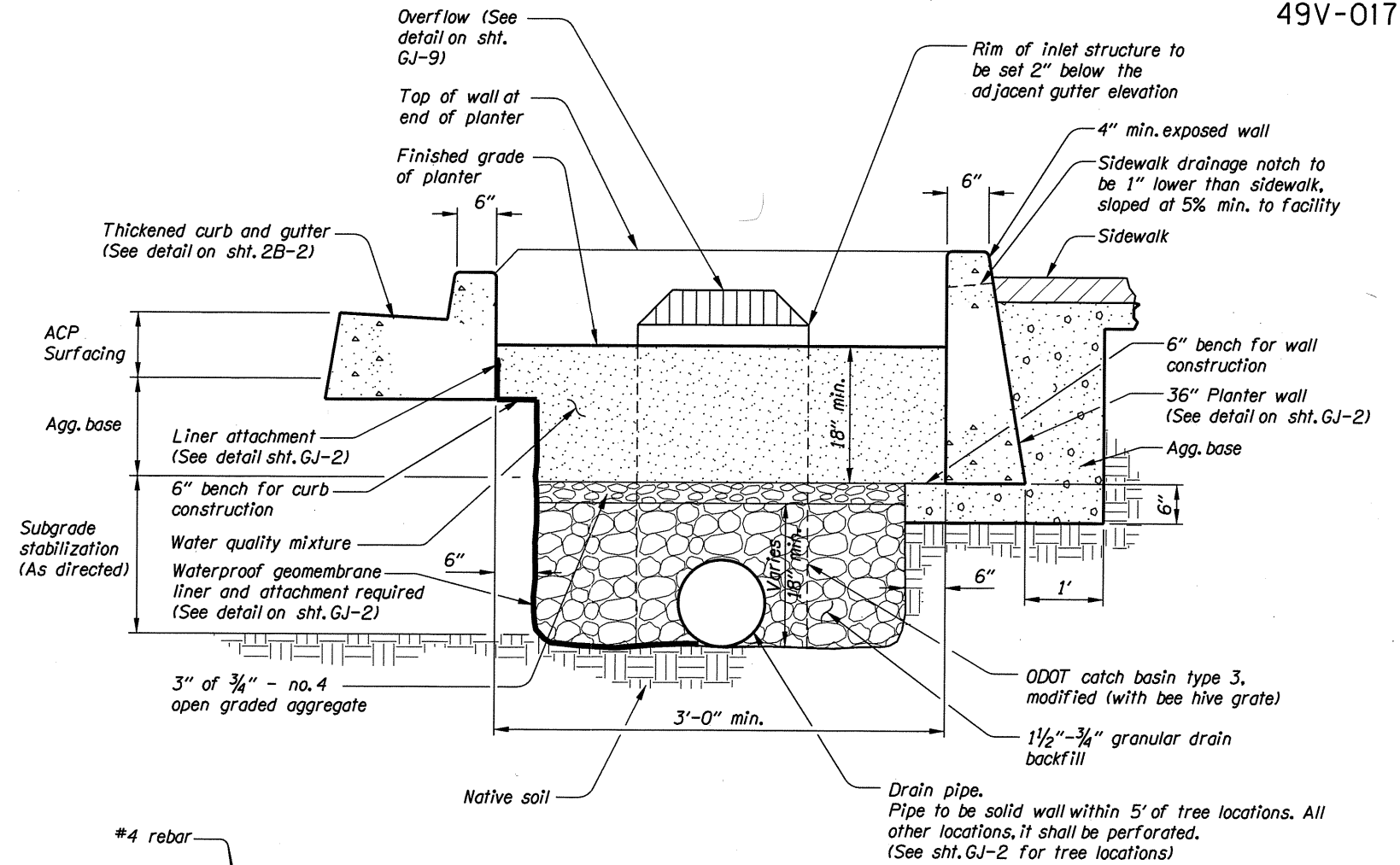
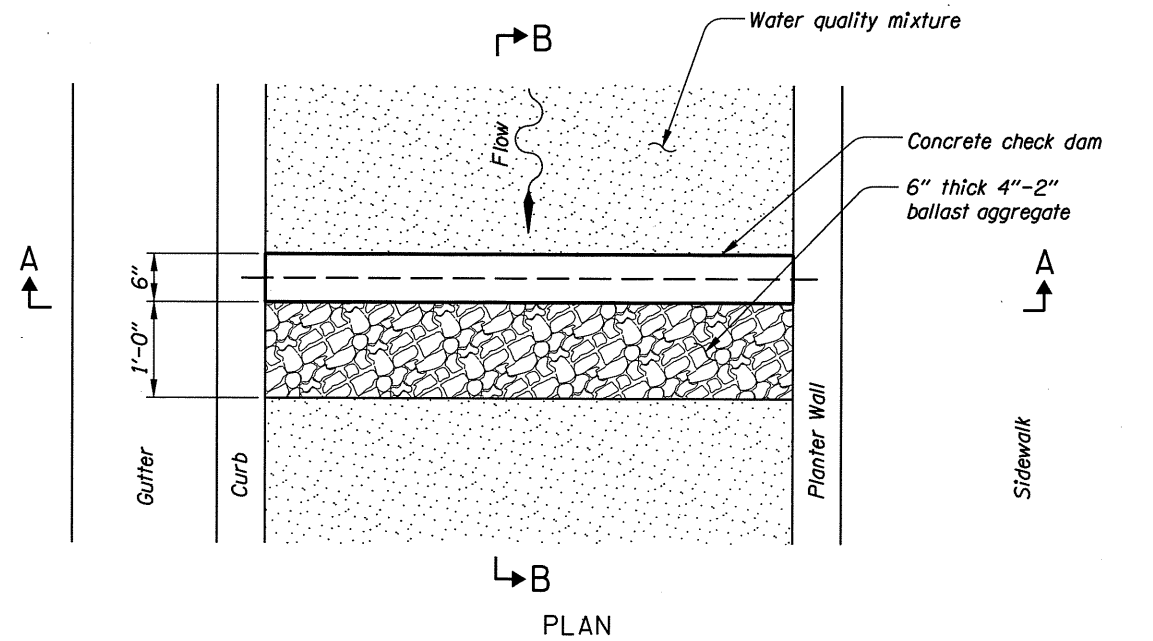

STORMWATER PLANTER

PLANTER CONCRETE CHECK DAM SPACING TABLE

12" drain pipe slope	Check dam spacing (min. one check dam per planter)	Elevation difference between upstream and downstream side of check dam
Less than 1.0%	50 feet	0.5 feet
1.0% to 1.6%	35 feet	0.7 feet
Greater than 1.6%	20 feet	0.5 feet

SECTION A-A
For planter details not shown, see planter detail above right

SECTION B-B

CONCRETE CHECK DAM

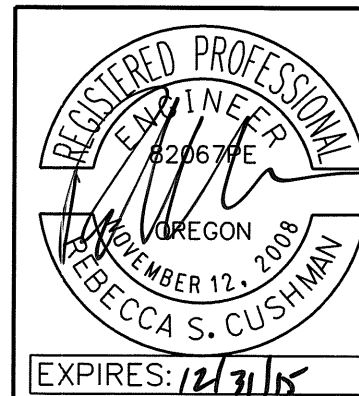

OREGON DEPARTMENT OF TRANSPORTATION

Parametrix

OR18: NEWBERG-DUNDEE BYPASS (PHASE 1G) (SPRINGBROOK RD) SEC. HILLSBORO-SILVERTON, PACIFIC HWY WEST, & SALMON RIVER HWYS. YAMHILL COUNTY

Design Team Leader - Rebecca Cushman
Designed By - Ryan Retzlaff
Drafted By - Jim Phillips

WATER QUALITY DETAILS

SHEET NO. GJ

CONSTRUCTION NOTES:

1. Adhere 30 mil. geomembrane liner to concrete with top coat of moldable sealant, or approved equal.
2. Secure geomembrane liner to concrete with 2" aluminum flat bar, placed as directed (curb side only).
3. Attach flat bar with concrete hit anchors, 24" o.c.
4. Trim excess liner to the top of the flat bar.

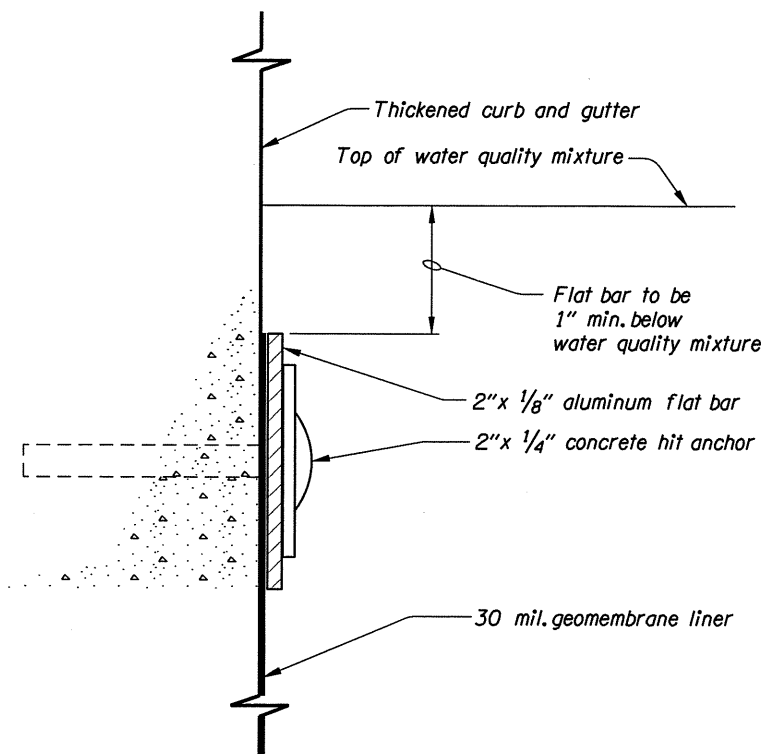

LINER ATTACHMENT DETAIL

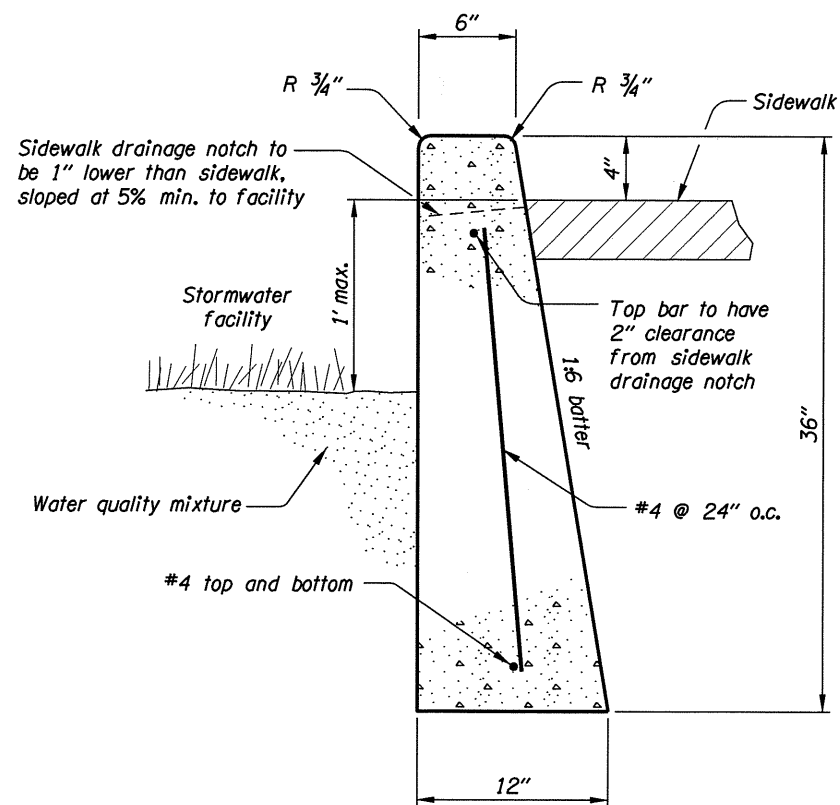

36" PLANTER WALL DETAIL

STORMWATER PLANTER TREE LOCATION TABLE

Tree #	Planter # (See GN series sheets for location)	Station and Offset
1	6	"SB" 19+61.00 Rt.
2	6	"SB" 20+00.80 Rt.
3	7	"SB" 20+71.10 Rt.
4	7	"SB" 21+10.90 Rt.
5	7	"SB" 21+50.80 Rt.
6	7	"SB" 21+90.60 Rt.
7	8	"SB" 22+78.60 Rt.
8	9A	"SB" 23+57.90 Rt.
9	9A	"SB" 23+98.30 Rt.
10	9A	"SB" 24+38.60 Rt.
11	9A	"SB" 24+79.00 Rt.
12	9A	"SB" 25+19.40 Rt.
13	9A	"SB" 25+59.70 Rt.
14	9A	"SB" 26+00.10 Rt.
15	9A	"SB" 26+40.50 Rt.
16	9B	"SB" 27+16.00 Rt.
17	9B	"SB" 27+55.80 Rt.
18	9B	"SB" 27+95.60 Rt.
19	9B	"SB" 28+35.30 Rt.
20	9B	"SB" 28+75.10 Rt.
21	9B	"SB" 29+14.90 Rt.
22	9B	"SB" 29+54.70 Rt.
23	9B	"SB" 29+94.50 Rt.
24	9B	"SB" 30+34.30 Rt.
25	9B	"SB" 30+74.10 Rt.
26	9B	"SB" 31+13.90 Rt.
27	9B	"SB" 31+53.70 Rt.
28	9B	"SB" 31+93.40 Rt.
29	9B	"SB" 32+33.20 Rt.
30	13	"SB" 35+11.10 Rt.
31	13	"SB" 35+52.10 Rt.
32	13	"SB" 35+93.10 Rt.
33	13	"SB" 36+34.10 Rt.
34	13	"SB" 36+75.10 Rt.
35	13	"SB" 37+16.00 Rt.
36	13	"SB" 37+57.00 Rt.
37	13	"SB" 37+98.00 Rt.
38	13	"SB" 38+39.00 Rt.
39	13	"SB" 38+80.00 Rt.
40	15	"SB" 39+57.20 Rt.
41	15	"SB" 39+95.70 Rt.
42	15	"SB" 40+33.90 Rt.
43	17	"SB" 41+08.20 Rt.
44	17	"SB" 41+46.90 Rt.
45	18	"SB" 42+08.50 Rt.
46	19	"SB" 42+59.70 Rt.
47	19	"SB" 42+99.20 Rt.
48	24	"SB" 46+28.90 Rt.
49	24	"SB" 46+66.40 Rt.
50	25	"SB" 47+34.60 Rt.
51	25	"SB" 47+74.30 Rt.
52	25	"SB" 48+14.10 Rt.
53	25	"SB" 48+53.90 Rt.
54	25	"SB" 48+93.60 Rt.
55	25	"SB" 49+33.40 Rt.
56	28	"SB" 50+89.50 Rt.
57	28	"SB" 51+30.00 Rt.
58	28	"SB" 51+70.50 Rt.
59	28	"SB" 52+11.00 Rt.
60	28	"SB" 52+51.50 Rt.
61	28	"SB" 52+92.00 Rt.
62	28	"SB" 53+32.50 Rt.
63	28	"SB" 53+73.00 Rt.
64	28	"SB" 54+13.50 Rt.
65	28	"SB" 54+54.00 Rt.

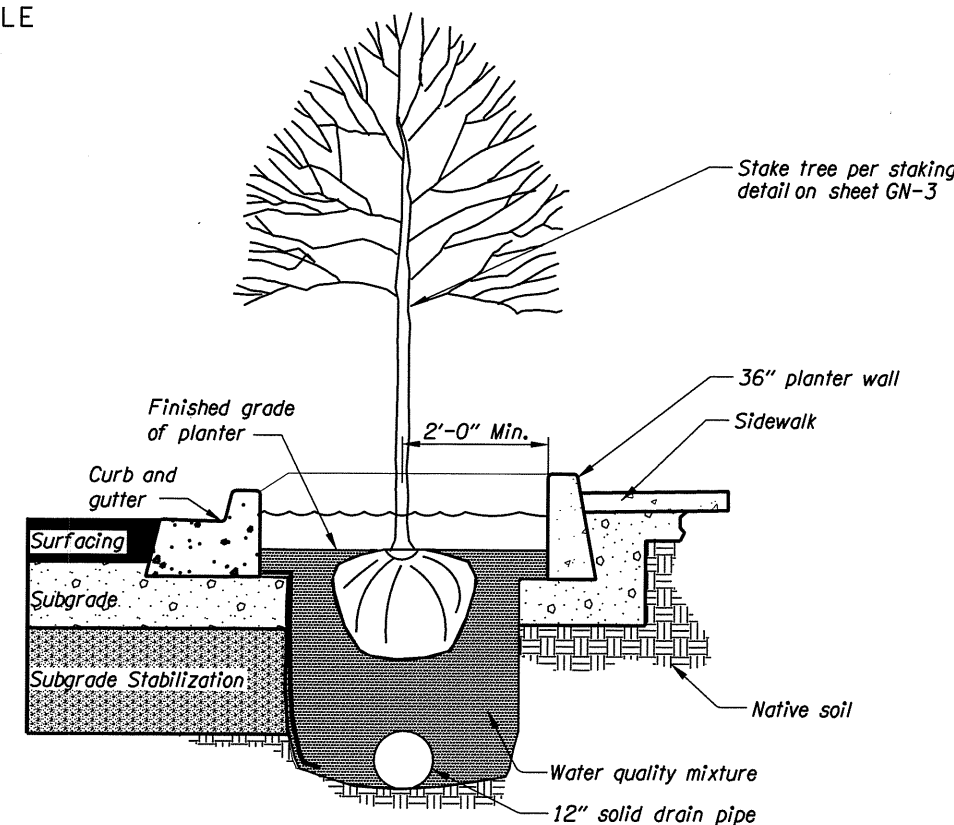

STORMWATER PLANTER PLANTING DETAIL

For planting details not shown, see detail sht. GN-4
For planter details not shown, see detail sht. GJ

PLANTER CONSTRUCTION NOTES:

1. Drain pipe to be solid wall within 5' of tree locations. All other locations, it shall be perforated.
2. Water quality mixture shall extend full depth of stormwater planter within 5' of tree locations. Omit Granular drain rock.

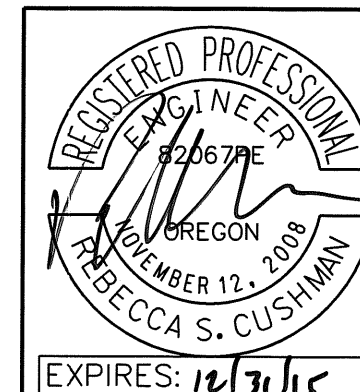

OREGON DEPARTMENT OF TRANSPORTATION

Parametrix

OR18: NEWBERG-DUNDEE BYPASS (PHASE 1G)
(SPRINGBROOK RD) SEC.
HILLSBORO-SILVERTON, PACIFIC HWY WEST, &
SALMON RIVER HWYS.
YAMHILL COUNTY

Design Team Leader - Rebecca Cushman
Designed By - Ryan Retzlaff
Drafted By - Jim Phillips

WATER QUALITY DETAILS

SHEET NO.
GJ-2

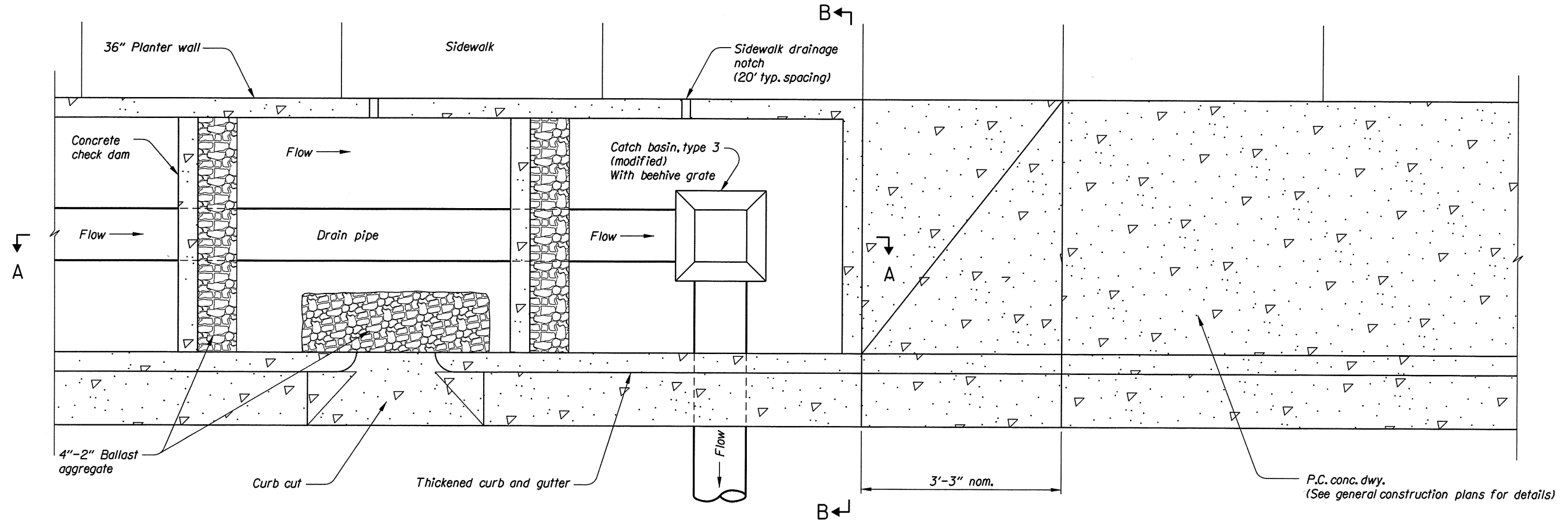

PLAN

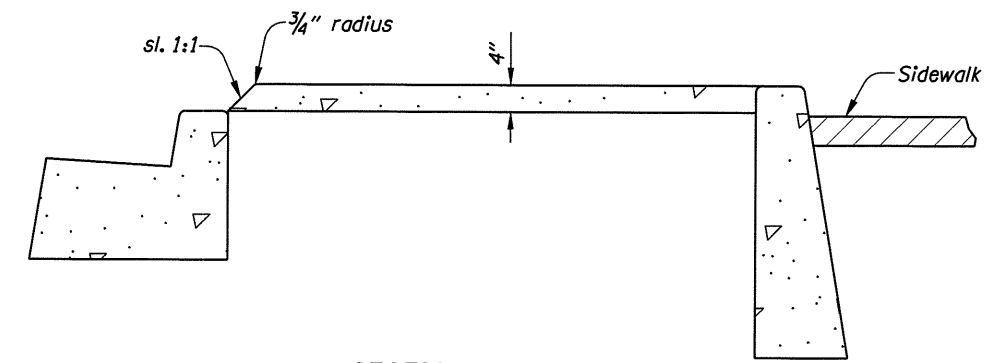

SECTION B-B

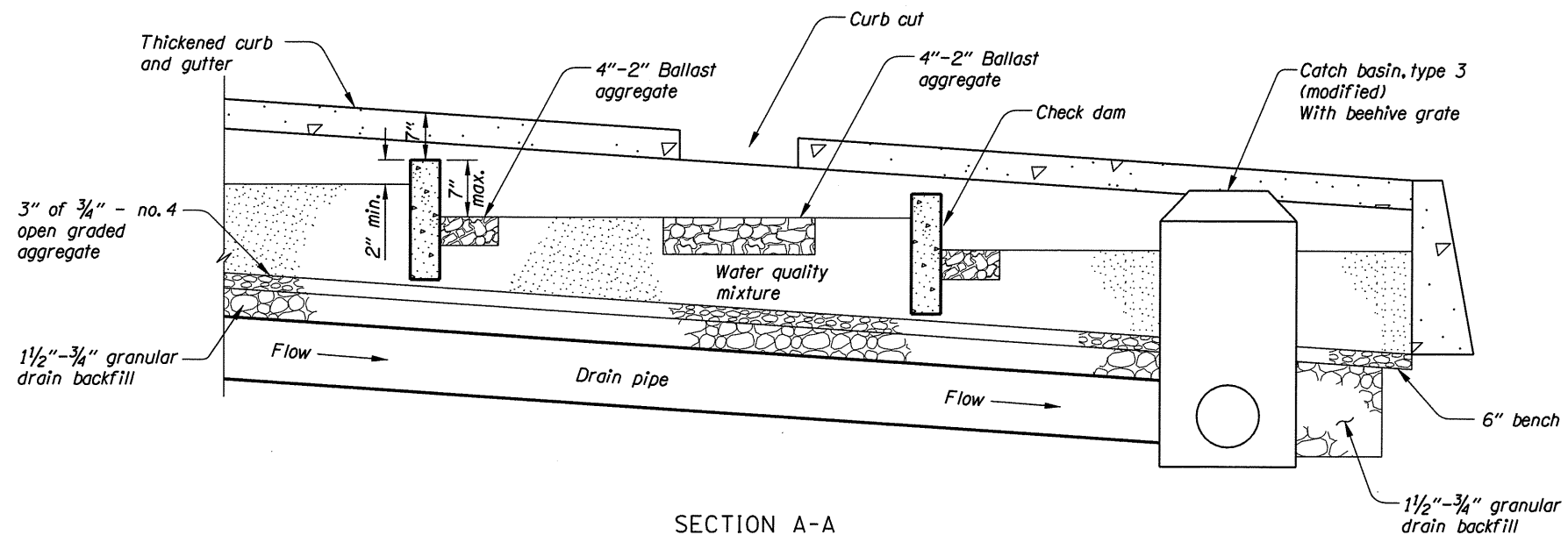

SECTION A-A

PLANTER PLAN AND SECTION

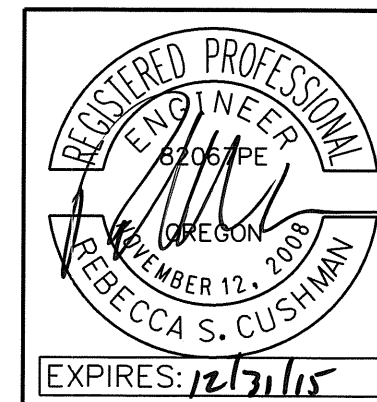

OREGON DEPARTMENT OF TRANSPORTATION	
Parametrix	
OR18: NEWBERG-DUNDEE BYPASS (PHASE 1G) (SPRINGBROOK RD) SEC. HILLSBORO-SILVERTON, PACIFIC HWY WEST, & SALMON RIVER HWYS. YAMHILL COUNTY	
Design Team Leader - Rebecca Cushman Designed By - Ryan Retzlaff Drafted By - Jim Phillips	
WATER QUALITY DETAILS	SHEET NO. GJ-3

CLEANOUT TABLE

Cleanout #	Sta. and offset	Cleanout #	Sta. and offset
1	"HSc" 44+21, 35.50' Lt.	41	"SB" 27+46, 26.00' Rt.
2	"HSc" 45+25, 35.50' Lt.	42	"SB" 28+85, 26.00' Rt.
3	"HSc" 46+25, 35.60' Lt.	43	"SB" 29+25, 24.25' Lt.
4	"HSc" 47+60, 37.90' Lt.	44	"SB" 29+85, 26.00' Rt.
5	"HSc" 48+60, 39.00' Lt.	45	"SB" 30+91, 26.00' Rt.
6	"HSc" 49+60, 39.00' Lt.	46	"SB" 31+00, 24.25' Lt.
7	"HSc" 49+72, 39.00' Lt.	47	"SB" 31+85, 26.00' Rt.
8	"HSc" 50+75, 39.90' Lt.	48	"SB" 33+16, 25.00' Rt.
9	"HSc" 51+60, 32.00' Rt.	49	"SB" 33+58, 24.25' Lt.
10	"HSc" 53+73, 40.50' Rt.	50	"SB" 34+50, 24.25' Lt.
11	"HSc" 54+75, 40.50' Rt.	51	"SB" 35+63, 26.00' Rt.
12	"HSc" 56+20, 40.50' Rt.	52	"SB" 35+85, 24.25' Lt.
13	"HSc" 57+30, 54.50' Lt.	53	"SB" 37+63, 24.25' Lt.
14	"HSc" 57+85, 40.50' Rt.	54	"SB" 36+60, 26.00' Rt.
15	"HSc" 58+30, 54.42' Lt.	55	"SB" 37+65, 26.00' Rt.
16	"HSc" 59+30, 45.24' Lt.	56	"SB" 38+60, 24.25' Lt.
17	"HSc" 60+10, 40.50' Lt.	57	"SB" 38+60, 26.00' Rt.
18	"HSc" 61+15, 40.50' Lt.	58	"SB" 40+14, 24.25' Lt.
19	"HSc" 62+15, 40.50' Lt.	59	"SB" 40+40, 26.00' Rt.
20	"HSc" 63+15, 40.50' Lt.	60	"SB" 40+67, 24.25' Lt.
21	"HSc" 64+15, 40.50' Lt.	61	"SB" 41+58, 26.00' Rt.
22	"HSc" 66+23, 40.50' Lt.	62	"SB" 41+70, 24.25' Lt.
23	Not Used	63	"SB" 43+44, 24.50' Rt.
24	Not Used	64	"SB" 43+53, 24.25' Lt.
25	"IP" 10+85, 34.22' Rt.	65	"SB" 44+50, 24.25' Lt.
26	"IP" 10+90, 28.20' Lt.	66	"SB" 44+65, 24.25' Rt.
27	"IP" 11+85, 30.64' Rt.	67	"SB" 45+53, 24.25' Lt.
28	"IP" 11+92, 28.20' Lt.	68	"SB" 45+57, 24.25' Rt.
29	"SB" 10+85, 38.25' Lt.	69	"SB" 46+56, 24.25' Lt.
30	"SB" 11+85, 38.25' Lt.	70	"SB" 46+72, 26.00' Rt.
31	"SB" 12+91, 41.70' Lt.	71	"SB" 47+50, 26.00' Rt.
32	"SB" 14+30, 29.50' Lt.	72	"SB" 47+85, 24.25' Lt.
33	"SB" 20+10, 26.00' Rt.	73	"SB" 48+47, 26.00' Rt.
34	"SB" 21+20, 26.00' Rt.	74	"SB" 48+88, 24.25' Lt.
35	"SB" 22+07, 26.00' Rt.	75	"SB" 49+55, 26.00' Rt.
36	"SB" 23+68, 26.00' Rt.	76	"SB" 51+65, 26.00' Rt.
37	"SB" 24+72, 26.00' Rt.	77	"SB" 52+17, 24.25' Lt.
38	"SB" 24+86, 26.00' Rt.	78	"SB" 52+74, 26.00' Rt.
39	"SB" 25+70, 26.00' Rt.	79	"SB" 52+84, 26.00' Rt.
40	"SB" 27+07, 25.50' Lt.	80	"SB" 53+87, 26.00' Rt.
		81	"SB" 50+56, 24.25' Lt.

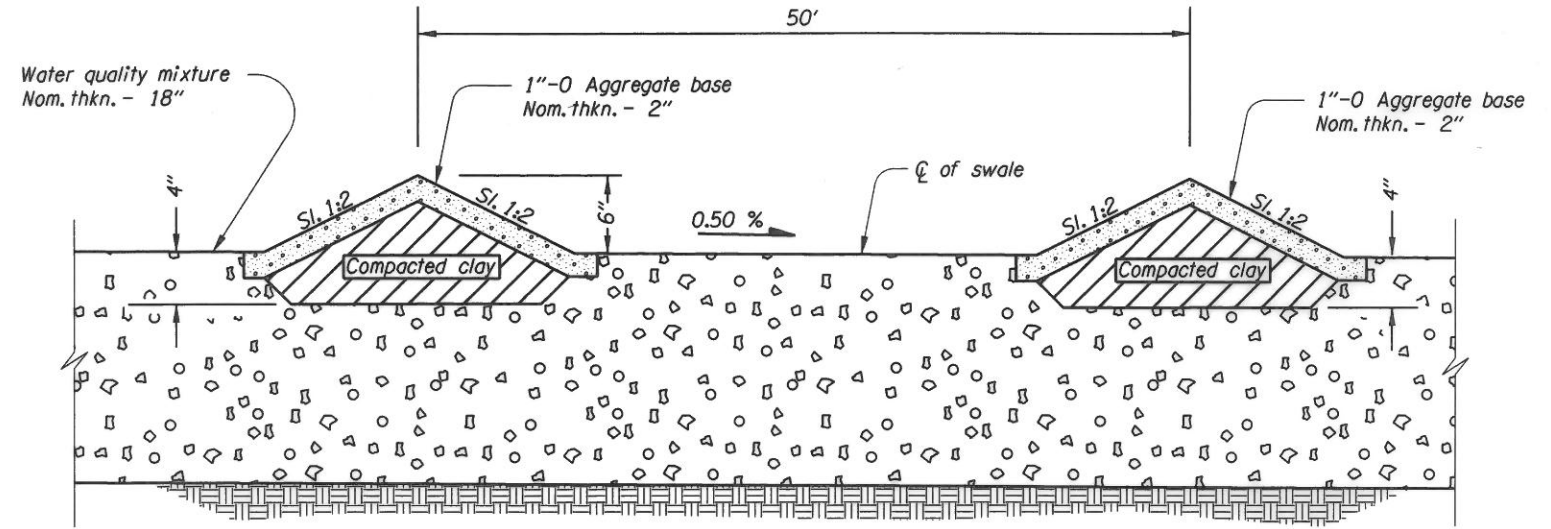

SWALE PROFILE SECTION

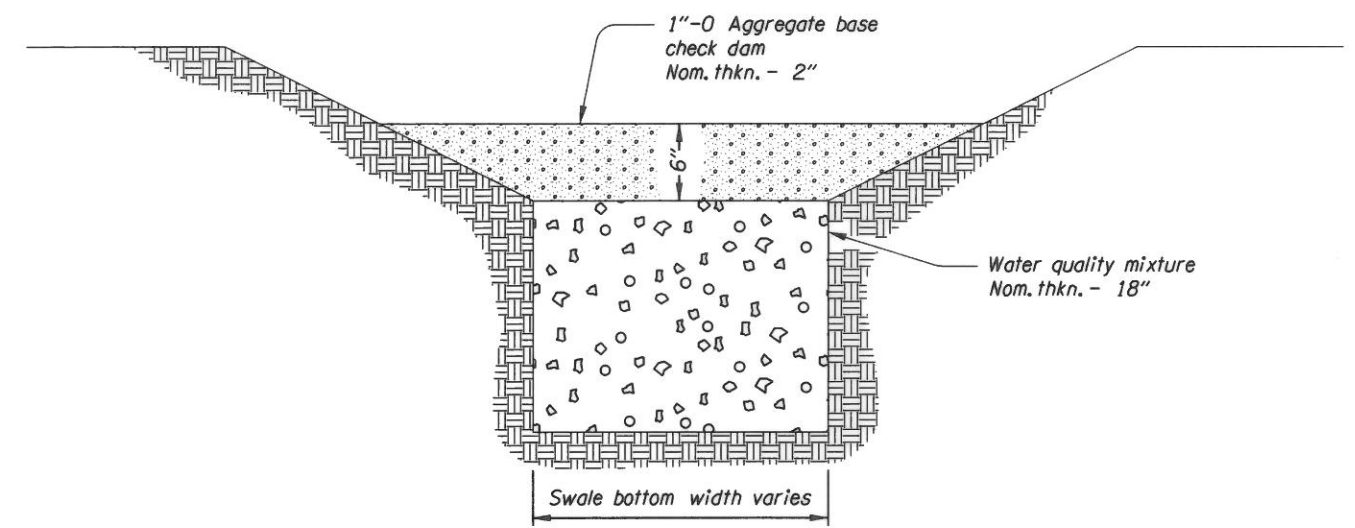

SWALE SECTIONS
WATER QUALITY BIOFILTRATION SWALE

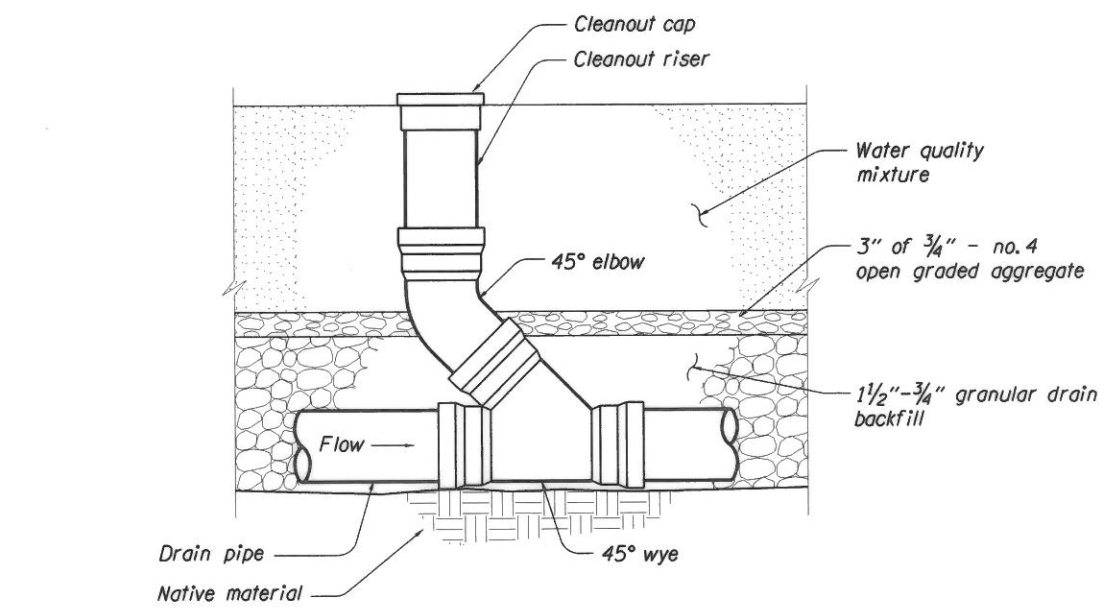

CLEANOUT DETAIL

- NOTES:**
1. Hand tamp water quality mixture material directly under check dam.
 2. Key clay core into water quality mixture material.

No.	DATE	REVISIONS	BY
1	03-31-16	Deleted Wilsonville Rd. connection to Hwy 219, & revised drainage design	J.A.P.
2	05-17-16	Updated stormwater planter design and adjusted cleanout spacing	J.A.P.
3	01-19-17	Adjusted storm planter, pipes, inlets, and cleanouts for new driveway location	J.A.P.



OREGON DEPARTMENT OF TRANSPORTATION

Parametrix

OR18: NEWBERG-DUNDEE BYPASS (PHASE 1G) (SPRINGBROOK RD) SEC. HILLSBORO-SILVERTON, PACIFIC HWY WEST, & SALMON RIVER HWYS. YAMHILL COUNTY

Design Team Leader - Rebecca Cushman
Designed By - Ryan Retzlaff
Drafted By - Jim Phillips

WATER QUALITY DETAILS

SHEET NO. GJ-4

FRENCH DRAIN DATA TABLE

Sheet #	Note #	Align Sta.	Soundwall Sta.	Drain Pipe FL Elev "FL"	Offset "D"
6B	19	"SB" 27+37, 36.82' Lt.	"SW1" 1+20	173.11	3.7
6B	19	"SB" 27+80, 35.53' Lt.	"SW1" 1+62.58	172.90	3.7
6B	4	"SB" 28+00, 36.23' Lt.	"SW1" 1+82.58	172.80	4.4
6B	39	"SB" 28+35, 36.23' Lt.	"SW1" 2+17.58	172.98	4.4
6B	20	"SB" 28+36.50, 36.23' Lt.	"SW1" 2+19.08	172.98	4.4
6B	20	"SB" 28+56.50, 35.53' Lt.	"SW1" 2+39.08	173.08	3.7
7B	26	"SB" 33+53.87, 35.53' Lt.	"SW1" 7+36.45	175.57	3.7
7B	24	"SB" 34+49.14, 35.53' Lt.	"SW2" 0+80.00	177.00	3.7
7B	9	"SB" 34+80, 36.63' Lt.	"SW2" 1+10.86	176.84	4.4
7B	25	"SB" 40+20.86, 36.23' Lt.	"SW2" 6+51.72	181.73	4.4
8B	3	"SB" 40+25.84, 36.23' Lt.	"SW2" 6+56.70	181.77	4.4
8B	36	"SB" 40+96.14, 36.03' Lt.	"SW2" 7+27	182.40	4.2
8B	36	"SB" 41+52.14, 35.53' Lt.	"SW2" 7+83	182.91	3.7
21B	3	"HSc" 78+67.65, 52.63' Rt.	"SW3" 0+00	169.76	4.4
21B	2	"HSc" 78+35.86, 51.20' Rt.	"SW3" 0+32	169.66	4.4
21B	2	"HSc" 78+33.86, 51.20' Rt.	"SW3" 0+34	168.36	4.4
21B	1	"HSc" 76+35.42, 50.38' Rt.	"SW3" 2+33	169.06	4.4
20B	4	"HSc" 74+75.66, 48.41' Rt.	"SW3" 3+92	169.44	4.4
20B	4	"HSc" 74+03.82, 49.00' Rt.	"SW3" 4+63.40	169.65	4.4
20B	2	"HSc" 73+93.77, 48.90' Rt.	"SW3" 4+73.40	169.65	4.4
20B	1	"HSc" 72+81.34, 49.30' Rt.	"SW3" 5+85.80	168.00	4.8
20B	1	"HSc" 72+81.34, 49.30' Rt.	"SW3" 5+92.87	171.00	4.8
20B	5	"HSc" 72+61.31, 97.93' Rt.	"SW3" 6+45	171.16	4.8

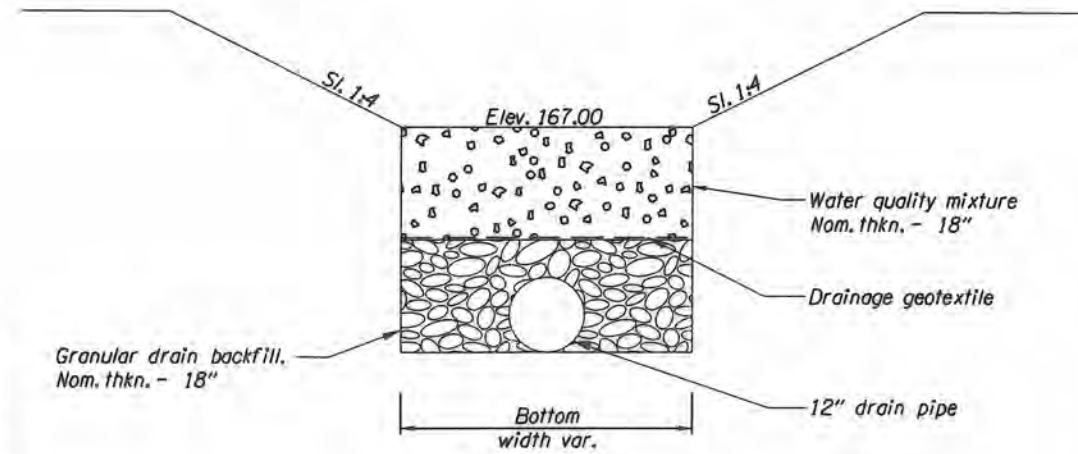

BIORETENTION POND #8

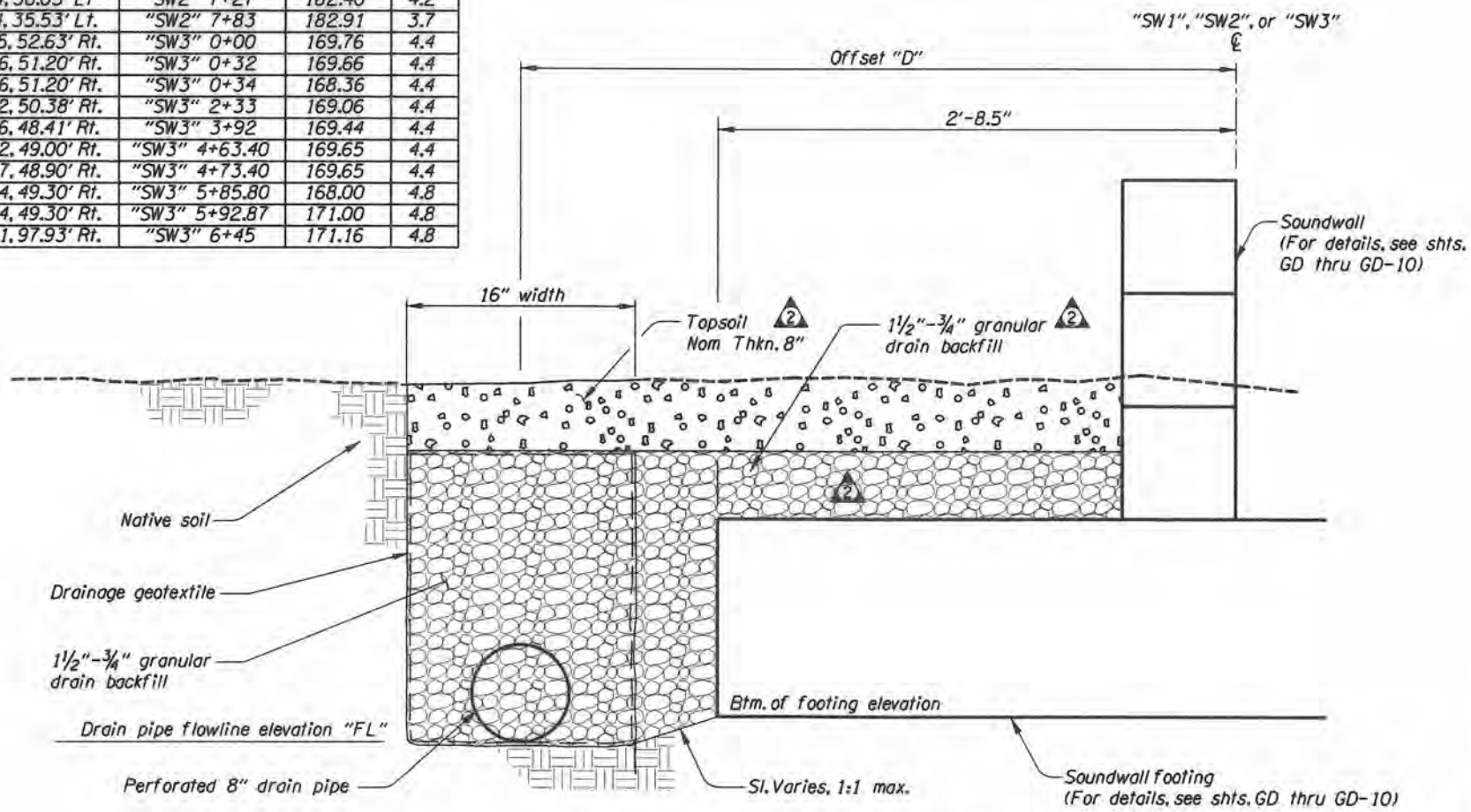

FRENCH DRAIN

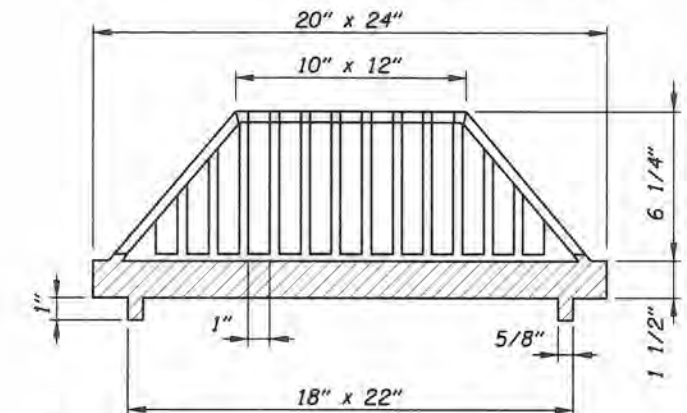
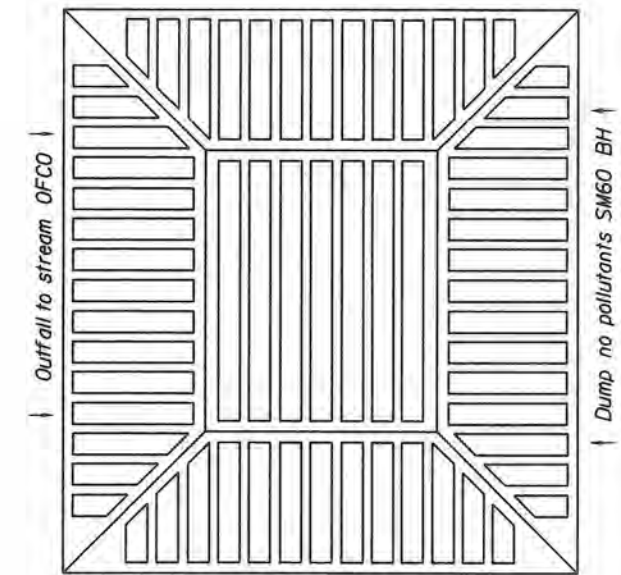

- NOTES:
1. Frame and behve grate, Olympic Foundry type SM60BH, or approved equal.
 2. Type 3 frame - steel (modified) will be required for retrofit of behve grate.
 3. See std. drg. RD378 for inlet base details.

CATCH BASIN, TYPE 3 (MODIFIED)
(WITH BEE HIVE GRATE)

No.	DATE	REVISIONS	BY
1	05-17-16	Revised stormwater design to fit field conditions	J.A.P.
2	05-17-16	Revised Soundwall backfill material and thickness	J.A.P.



OREGON DEPARTMENT OF TRANSPORTATION

Parametrix

OR18: NEWBERG-DUNDEE BYPASS (PHASE 1G)
(SPRINGBROOK RD) SEC.
HILLSBORO-SILVERTON, PACIFIC HWY WEST, &
SALMON RIVER HWYS.
YAMHILL COUNTY

Design Team Leader - Rebecca Cushman
Designed By - Ryan Retzlaff
Drafted By - Jim Phillips

WATER QUALITY DETAILS

SHEET NO. GJ-9

CURB CUT TABLE

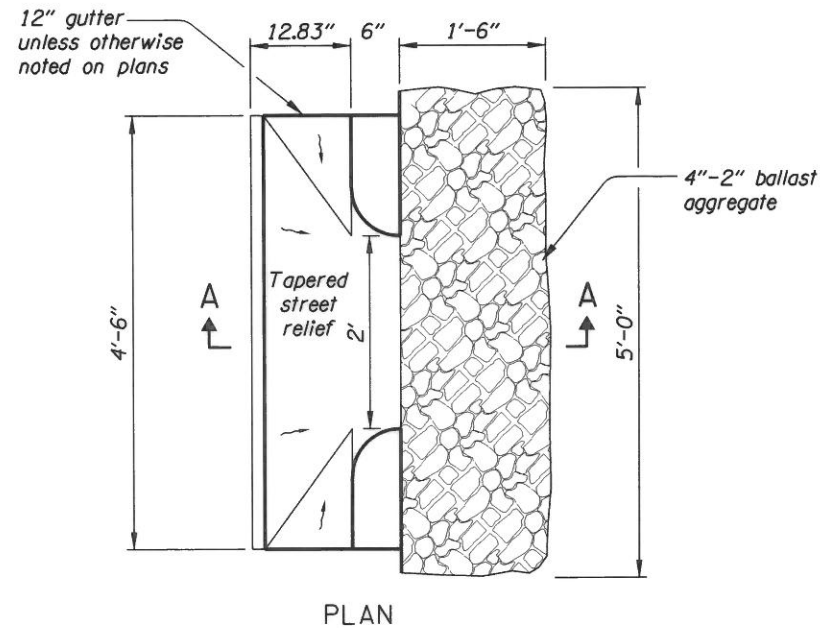

PLAN

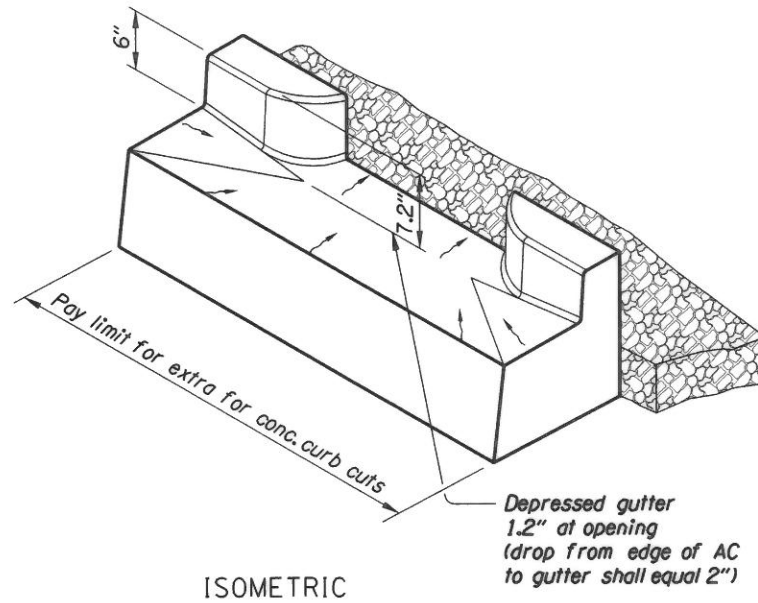

ISOMETRIC

- NOTES FOR STAGE CONSTRUCTION:**
1. For stage construction, omit curb cut section, place agg. base to top of HMAC base course.
 2. Complete construction of curb cut section for HMAC wearing course.
 3. Curb cuts between Sta. "SB" 15+00 and "SB" 55+00 can be constructed without staging.

Curb cut #	Station	Curb cut #	Station	Curb cut #	Station
1	"IP" 10+69.12 Rt.	53	"SB" 12+31.35 Lt.	105	"SB" 38+72.00 Lt.
2	"IP" 10+85.27 Lt.	54	"SB" 12+91.35 Lt.	106	"SB" 39+16.55 Rt.
3	"IP" 11+21.98 Rt.	55	"SB" 13+65.20 Lt.	107	"SB" 39+32.00 Lt.
4	"IP" 11+53.79 Lt.	56	"SB" 14+30.76 Lt.	108	"SB" 39+54.00 Rt.
5	"IP" 11+74.27 Rt.	57	"SB" 19+02.63 Rt.	109	"SB" 39+98.27 Lt.
6	"IP" 12+22.32 Lt.	58	"SB" 19+52.41 Rt.	110	"SB" 40+14.00 Rt.
7	"IP" 12+27.24 Rt.	59	"SB" 20+12.41 Rt.	111	"SB" 40+58.27 Lt.
8	"HSc" 44+15.85 Lt.	60	"SB" 20+85.01 Rt.	112	"SB" 41+06.60 Rt.
9	"HSc" 44+75.85 Lt.	61	"SB" 21+45.01 Rt.	113	"SB" 41+18.27 Lt.
10	"HSc" 45+35.85 Lt.	62	"SB" 22+05.01 Rt.	114	"SB" 41+56.41 Rt.
11	"HSc" 45+95.85 Lt.	63	"SB" 22+96.41 Rt.	115	"SB" 41+66.55 Lt.
12	"HSc" 46+55.85 Lt.	64	"SB" 23+56.73 Rt.	116	"SB" 42+23.13 Rt.
13	"HSc" 47+15.85 Lt.	65	"SB" 24+16.73 Rt.	117	"SB" 42+61.34 Lt.
14	"HSc" 47+75.85 Lt.	66	"SB" 25+36.73 Rt.	118	"SB" 42+81.94 Rt.
15	"HSc" 48+35.85 Lt.	67	"SB" 25+96.73 Rt.	119	"SB" 42+87.65 Lt.
16	"HSc" 48+95.85 Lt.	68	"SB" 26+50.83 Rt.	120	"SB" 43+41.94 Rt.
17	"HSc" 49+55.85 Lt.	69	"SB" 26+88.12 Rt.	121	"SB" 43+47.65 Lt.
18	"HSc" 50+15.85 Lt.	70	"SB" 27+09.00 Lt.	122	"SB" 44+07.65 Lt.
19	"HSc" 50+75.85 Lt.	71	"SB" 27+48.12 Rt.	123	"SB" 44+16.49 Rt.
20	"HSc" 50+83.78 Rt.	72	"SB" 27+69.00 Lt.	124	"SB" 44+64.54 Lt.
21	"HSc" 51+35.85 Lt.	73	"SB" 28+08.12 Rt.	125	"SB" 44+74.49 Rt.
22	"HSc" 51+58.53 Rt.	74	"SB" 28+60.00 Lt.	126	"SB" 45+10.23 Rt.
23	"HSc" 54+01.27 Rt.	75	"SB" 28+60.00 Lt.	127	"SB" 45+16.88 Lt.
24	"HSc" 54+61.27 Rt.	76	"SB" 29+15.55 Rt.	128	"SB" 45+57.49 Rt.
25	"HSc" 55+21.27 Rt.	77	"SB" 29+30.98 Lt.	129	"SB" 45+90.88 Lt.
26	"HSc" 55+81.27 Rt.	78	"SB" 29+75.55 Rt.	130	"SB" 46+25.00 Rt.
27	"HSc" 56+15.64 Lt.	79	"SB" 30+05.00 Lt.	131	"SB" 46+65.23 Lt.
28	"HSc" 56+41.27 Rt.	80	"SB" 30+35.55 Rt.	132	"SB" 46+70.41 Rt.
29	"HSc" 56+75.11 Lt.	81	"SB" 30+50.98 Lt.	133	"SB" 47+15.38 Rt.
30	"HSc" 57+06.27 Rt.	82	"SB" 30+95.55 Rt.	134	"SB" 47+17.38 Lt.
31	"HSc" 57+35.69 Lt.	83	"SB" 31+06.00 Lt.	135	"SB" 47+73.50 Rt.
32	"HSc" 57+61.27 Rt.	84	"SB" 31+55.55 Rt.	136	"SB" 47+78.48 Lt.
33	"HSc" 57+94.38 Lt.	85	"SB" 32+15.55 Rt.	137	"SB" 48+33.50 Rt.
34	"HSc" 58+21.27 Rt.	86	"SB" 32+64.02 Lt.	138	"SB" 48+38.48 Lt.
35	"HSc" 58+54.00 Lt.	87	"SB" 32+69.00 Rt.	139	"SB" 48+93.50 Rt.
36	"HSc" 58+81.27 Rt.	88	"SB" 32+97.86 Lt.	140	"SB" 48+98.48 Lt.
37	"HSc" 59+13.32 Lt.	89	"SB" 33+41.02 Rt.	141	"SB" 49+51.50 Rt.
38	"HSc" 59+72.96 Lt.	90	"SB" 33+57.86 Lt.	142	"SB" 50+75.00 Rt.
39	"HSc" 60+32.96 Lt.	91	"SB" 34+52.85 Lt.	143	"SB" 51+19.00 Lt.
40	"HSc" 60+92.96 Lt.	92	"SB" 34+96.55 Rt.	144	"SB" 51+18.63 Rt.
41	"HSc" 61+52.96 Lt.	93	"SB" 35+07.91 Lt.	145	"SB" 51+69.70 Lt.
42	"HSc" 62+12.96 Lt.	94	"SB" 35+56.55 Rt.	146	"SB" 51+78.63 Rt.
43	"HSc" 62+72.96 Lt.	95	"SB" 35+67.91 Lt.	147	"SB" 52+29.70 Lt.
44	"HSc" 63+32.95 Lt.	96	"SB" 36+16.55 Rt.	148	"SB" 52+38.63 Rt.
45	"HSc" 63+92.95 Lt.	97	"SB" 36+27.91 Lt.	149	"SB" 53+58.63 Rt.
46	"HSc" 64+52.95 Lt.	98	"SB" 36+76.55 Rt.	150	"SB" 54+18.63 Rt.
47	"HSc" 65+12.95 Lt.	99	"SB" 36+89.50 Lt.	151	"SB" 54+78.63 Rt.
48	"HSc" 65+72.95 Lt.	100	"SB" 37+36.55 Rt.	152	"SB" 50+60.00 Lt.
49	"HSc" 66+22.00 Lt.	101	"SB" 37+55.19 Lt.	153	Not Used
50	"SB" 10+51.35 Lt.	102	"SB" 37+96.55 Rt.	154	Not Used
51	"SB" 11+11.35 Lt.	103	"SB" 38+15.19 Lt.	155	Not Used
52	"SB" 11+71.35 Lt.	104	"SB" 38+56.55 Rt.		

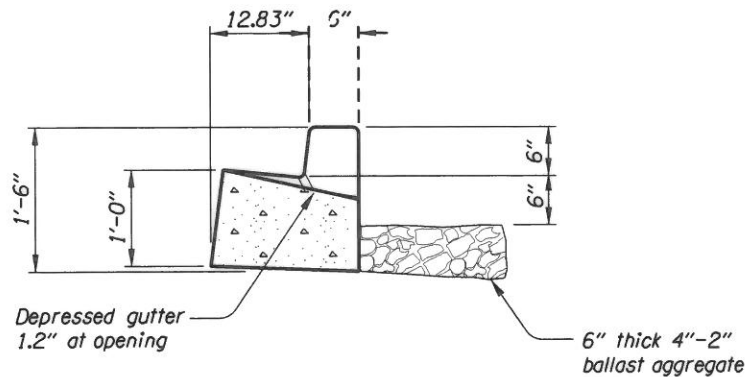

SECTION A-A

CONCRETE CURB CUT DETAIL

NOTE:
Refer to curb and gutter (modified) sht. 2B-2

No.	DATE	REVISIONS	BY
1	03-31-16	Deleted Wilsonville Rd. connection to Hwy 219, & revised drainage design	J.A.P.
2	01-19-17	Adjusted storm planter, pipes, inlets, and curb cuts for new driveway location	J.A.P.



OREGON DEPARTMENT OF TRANSPORTATION

Parametrix

OR18: NEWBERG-DUNDEE BYPASS (PHASE 1G) (SPRINGBROOK RD) SEC.
HILLSBORO-SILVERTON, PACIFIC HWY WEST, & SALMON RIVER HWYS.
YAMHILL COUNTY

Design Team Leader - Rebecca Cushman
Designed By - Ryan Retzlaff
Drafted By - Jim Phillips

WATER QUALITY DETAILS

SHEET NO. GJ-11

Appendix C

Content:

- **Maintenance Tables**

Table 1: General Maintenance

Maintenance Component	Defect or Problem	Condition When Maintenance is Needed	Recommended Maintenance to Correct Problem
Annual Visual Inspection and Maintenance	Routine inspection	<p>Facilities should be inspected annually prior to fall rains.</p> <p>If appropriate, also inspect the facility after the first significant rain event following dry spell (e.g. the first 24-hour rainfall greater than 0.5 inches after summer)</p>	<p>Identify existing and potential operational problems.</p> <p>Repair damaged components that are critical to the operation of the feature (e.g. flow control valves, liners, underdrains, and pipes) as soon as practical.</p> <p>Schedule routine maintenance such as mowing, sump cleanout, lube moving parts, repairs, etc.</p> <p>If the facility is problematic, schedule additional inspections or maintenance.</p> <p>Repair or replace facility field markers according to Technical Bulletin GE10-01(B). A marked facility has an O&M Plan.</p>
	<p>Maintenance of ancillary structures, if present</p> <p>Examples include</p> <ul style="list-style-type: none"> • Flow splitter manhole • Diversion manhole • Catch basin • Shut-off valve assembly • Pretreatment or primary treatment manhole • Large detention pipe • Vault • Outfall 	Damage or problems are observed or anticipated during the annual inspection.	<p>Grease moving parts to ensure proper operation.</p> <p>Remove sediment from sumps, vaults, catch basins, and structures to prevent the release of oil or sediment. Annual cleaning is recommended. The use of a Vactor® truck is allowed unless prohibited in the facility's O&M manual</p> <p>Repair or replace damaged orifice assembly/riser pipe. Restore to design standards. Be aware of possible confined space requirements.</p> <p>Repair or replace damaged gates, locks, chains, etc that are used to secure valves and access points to prevent vandalism</p>
General	Temporary erosion control hampers maintenance	Erosion control remains from project construction (contractor did not remove)	Contact contractor to complete work OR remove temporary erosion control that is not specified in the O&M Plan.

Table 1: General Maintenance

Maintenance Component	Defect or Problem	Condition When Maintenance is Needed	Recommended Maintenance to Correct Problem
General	Spilled material has entered the pond or structures	Oil, fuel, or other pollutants are evident following a spill event or accident.	<p>Utilize valves or other features, if present, to contain the spilled material.</p> <p>Remove and properly manage spilled material and contaminated soil.</p> <p>Contact Region HazMat or spill response company for spill cleanup assistance where appropriate.</p> <p>Contact a Region Hydraulic Engineer for technical assistance with pond restoration, if necessary.</p>
	Litter (trash and debris)	Trash poses a hazard, inhibits function, or is aesthetically unacceptable (e.g. evidence of dumping).	<p>Remove problematic trash and debris as soon as practical. There should be no evidence of dumping.</p> <p>Remove non-problematic trash in accordance with District litter practices.</p>
	Insects	Insects interfere with maintenance activities.	Implement vector control in accordance with County Health and District practices.
	Vegetation growth (brushing)	Vegetation growth restricts access, limits sight distance, obstructs water flow, or interferes with maintenance activity.	<p>Remove vegetation in or around grates that obstruct (or could obstruct) flow.</p> <p>Avoid mowing or removing vegetation that does not need to be controlled.</p> <p>Avoid removing vegetation too low to the ground. NOTE: Removing vegetation too near to the ground may result in scalping of the soil, unwanted damaged to vegetation, or growth of unwanted plant species.</p> <p>Heavy equipment is not allowed within aboveground water quality and detention facilities.</p>
	Noxious weed growth	Control of noxious weeds is required by law or prescribed in the District IVM Plan	<p>Remove noxious weeds in accordance with the District IVM Plan.</p> <p>Follow Environmental Protection Agency (EPA) label and ODOT policies on herbicide usage.</p>
General	Hazard trees	Trees are found to be weakened, unsound, undermined, leaning, or exposed and may fall across the highway	<p>Remove hazard trees as soon as practical.</p> <p>Where appropriate, consult an ODOT Forester for help identifying or removing hazard trees.</p>

Table 1: General Maintenance

Maintenance Component	Defect or Problem	Condition When Maintenance is Needed	Recommended Maintenance to Correct Problem
	Tree growth	Tree growth restricts access, obstructs function, jeopardizes infrastructure, or interferes with maintenance actions.	<p>Prune or remove as needed to maintain access, function, and tree health.</p> <p>Manage potentially problematic woody material before the trees reach 6 inches diameter at breast height (DBH).</p> <p>Consult an ODOT Forester for the removal or management of trees greater than 6 inches DBH. Obtain permits where appropriate.</p> <p>Refer to the District IVM Plan for the management of smaller trees.</p> <p>Avoid removing trees that will not interfere with the operation or maintenance of the facility.</p>

Table 3: Maintenance of Water Quality Bio-Infiltration Swales

Swales should provide even sheet flow and infiltration that moves water from the inlet to the outlet.

Maintenance Component	Defect or Problem	Condition When Maintenance is Needed	Recommended Maintenance to Correct Problem
General	Follow applicable Guidance from Table 1 AND applicable guidance from this table.		
	Vegetation growth (brushing)	<p>Vegetation growth restricts access, limits sight distance, obstructs water flow, or interferes with maintenance activity.</p> <p>Swales should not be mowed. Vegetation should be cut down in targeted areas where needed.</p>	<p>Mow access, berms, and sideslopes as noted in District Integrated Vegetation Management (IVM) Plan.</p> <p>Heavy equipment is not allowed on the swale bottom.</p>
	Sediment accumulation in pre-treatment features (e.g. forebays, basins, sedimentation manholes)	<p>Sediment affects flow.</p> <p>Sediment jeopardizes infrastructure.</p>	<p>Remove sediment that prevents adequate drainage into swale.</p> <p>Use methods that minimize disturbance to surrounding vegetation.</p> <p>Heavy equipment is not allowed on swale bottoms.</p> <p>Sediment may contain oil and other pollutants, especially in areas with high ADT. Refer to the ODOT Maintenance Environmental Management System (EMS) Manual for the disposal of contaminated sediment.</p> <p>Note: Pollutant concentrations may increase if sediment is not routinely removed.</p>
	Sediment accumulation along swale bottom	<p>Sediment inhibits the flow of water through the vegetation</p> <p>Sediment inhibits vegetation growth.</p>	<p>Where practical use a Vactor® truck to remove sediment from vegetated areas. When Vactoring® is not practical, follow ditch cleaning practices.</p> <p>Restore slope and geometry to design standards, if necessary.</p> <p>Reseed/replant vegetation cover where needed.</p> <p>Stormwater should infiltrate or flow toward outlet once inflow has ceased.</p>

Table 3: Maintenance of Water Quality Bio-Infiltration Swales

Swales should provide even sheet flow and infiltration that moves water from the inlet to the outlet.

Maintenance Component	Defect or Problem	Condition When Maintenance is Needed	Recommended Maintenance to Correct Problem
Swale Components	Erosion	Side slopes show evidence of erosion greater than 2 inches deep and the potential for continued erosion is evident.	<p>Promptly address erosion that causes immediate problems (e.g. damage to highway or highway structure)</p> <p>Schedule non-urgent repairs with routine work.</p> <p>Stabilize slope using appropriate erosion control and repair methods.</p> <p>Repair the cause of the erosion where possible.</p> <p>If necessary, contact the ODOT Erosion Control Coordinator to evaluate the condition.</p>
	Poor vegetation coverage	Vegetation is sparse or eroded patches occur in more than 10 percent of swale.	<p>Repair and reseed as appropriate to restore coverage.</p> <p>Install erosion control measures as needed.</p> <p>Trim overhanging limbs and remove brushy vegetation that limit grass growth (provide too much shade).</p>
	Missing or eroded amended soil mix	Bare soil is observed over 10 percent of the amended area.	<p>Identify and resolve erosion problem</p> <p>Add amended soil. Contact a Region Hydraulics Engineer for required material specifications.</p>
	Amended soil mix along swale bottom is clogged	Standing water is observed for seven (7) consecutive days or longer from May through October.	<p>Remove and replace amended soil mix. Contact a Region Hydraulics Engineer for required material specifications.</p> <p>Replace or repair damaged underlying drainage geotextile, impermeable liner, drain piping, and granular drain backfill material when applicable.</p>
	Granular drain backfill material for underdrain pipe plugged	Amended soil mix has been replaced and standing water is still observed for seven (7) consecutive days or longer from May through October.	<p>Remove and replace granular drain backfill material. Contact a Region Hydraulics Engineer for required material specifications.</p> <p>Install new drainage geotextile over new granular drain backfill material.</p> <p>Replace amended soil mix.</p>

Table 3: Maintenance of Water Quality Bio-Infiltration Swales

Swales should provide even sheet flow and infiltration that moves water from the inlet to the outlet.

Maintenance Component	Defect or Problem	Condition When Maintenance is Needed	Recommended Maintenance to Correct Problem
Swale Components	<p>Impermeable liner damage</p> <p>NOTE: Liners (if installed) are typically below the vegetation surface and may not be visible.</p> <p>Fabric wrapped around underdrains is not a liner.</p>	<p>Liner is damaged (e.g. during sediment removal or by motoring public). Liner is damaged when condition allows potential contamination to be released to the subsurface.</p>	<p>Repair or replace the liner with similar material. Replace top soil and grass as appropriate.</p> <p>Features with liners, typically have maintenance option limitations; check the O&M Manual.</p> <p>If necessary, contact a Region Hydraulics Engineer for technical assistance.</p>
	<p>Obstruction or blockage of pipes</p>	<p>Water does not flow in, through, or out of the swale.</p>	<p>Remove obstructions to restore flow (e.g. remove trash, debris, sediment, or vegetation as necessary).</p> <p>Jet rodders may be used to clean piping unless specifically prohibited in the O&M plan.</p>
	<p>Flow spreader is uneven or clogged</p>	<p>Water does not flow evenly across the structure</p>	<p>Clean sump or forebay as needed to maintain capacity.</p> <p>Clean or repair spreader as needed to provide a uniform flow and prevent erosion. Level portions of the flow spreader that have settled.</p>