

# OPERATION & MAINTENANCE MANUAL

## Water Quality Planter

Manual prepared: August 2019

DFI No. D00938, D00939



**Figure 1: Typical Planter**

**Note this image reflects appearance during construction, to be updated with post construction photo.**

## 1. Identification

Drainage Facility ID (DFI): D00938  
Facility Type: Water Quality Planter  
Construction Drawings: 49V-060  
Locations: District: 1  
Highway No.: 009  
Mile Post: 65.77 – 65.78

Drainage Facility ID (DFI): D00939  
Facility Type: Water Quality Planter  
Construction Drawings: 49V-060  
Locations: District: 1  
Highway No.: 009  
Mile Post: 65.77 – 65.78

## 2. Manual Purpose

The purpose of this manual is to outline inspection needs and summarize maintenance actions for water quality planters.

## 3. Facility Location

The location map below details the facility location. The highway, mile posts, side streets, access location, and stormwater flow directions are noted on the map.

Facility location type: In sidewalk

Flow direction: Varies



**Figure 2: Facility Location Map**

Note facilities were not constructed at the time the aerial photograph was taken. This map will be updated.

#### 4. Facility Summary

The length and width of the WQ Planter is based on the dimensions of the inside of the treatment cell.

The length and width of the WQ Planters are:

Facility DFI	Length (Feet)	Width (Feet)
D00938	56	varys 2 - 8
D00939	56	varys 2 -8

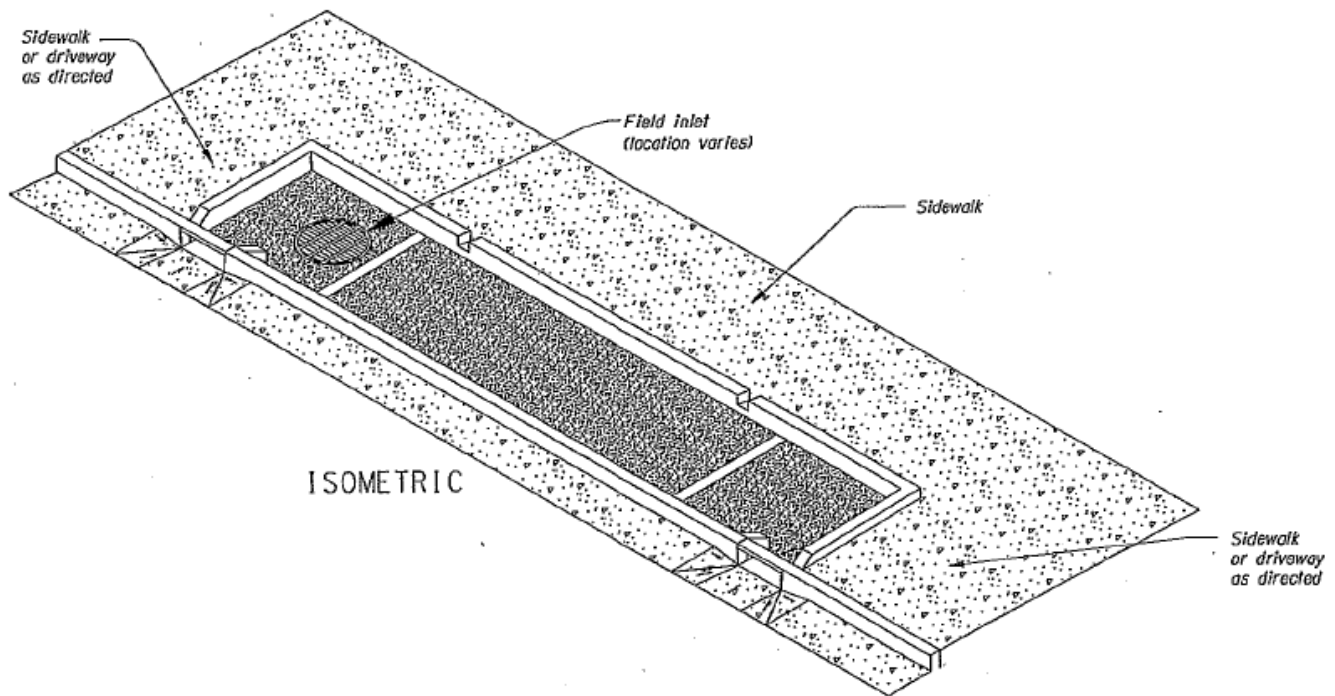

---

**Site Specific Information:** The planters have blended compost and topsoil mixture. There are no bypass inlets on the planters. Water flows from the gutter, into curb openings, underneath the sidewalk and falls onto concrete splash pads before making contact with the plants and water quality soil mix. Below the 24" of water quality soil mix 3" of filter rock and 12" of granular drain rock exist. An impermeable liner lines the bottom and walls of the planter box. Finally, water exits the system through a 4" perf pipe and into the storm drain system. A clean out for the 4" pipe is shown in the photo below.

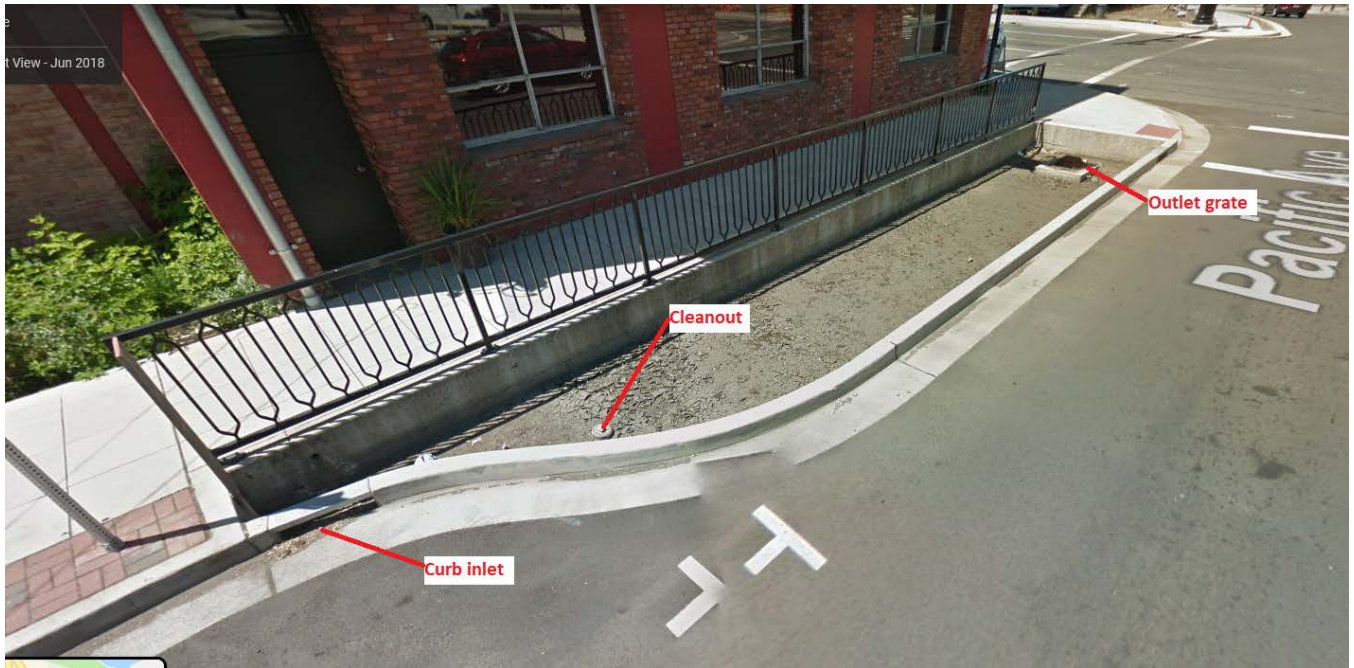

**Figure 3: Facility Components**

## 5. Facility Access

Maintenance access to the facility: Curb and gutter (travel lane)

### Lane Closure Needed

Water quality planters do not typically have access roads/access pads, nor are they gated, as they are located in urban areas alongside sidewalks and curbs. Use caution when accessing these facilities as there may be pedestrians or cyclists in the vicinity.

## 6. Operational Components / Maintenance Items

### Classification and Standard Operational (Op) Plan:

This facility is classified as a:

<input type="checkbox"/> <b>Filterra (Op Plan A)</b>	<input checked="" type="checkbox"/> <b>WQ Planter (Op Plan B)</b>	<input type="checkbox"/> <b>MWS (Op Plan C)</b>
A Filterra is a single chamber treatment cell that utilizes filter media, a plant, and a perforated underdrain.	A WQ Planter is a single chamber treatment cell that utilizes plants, filter media, and a perforated underdrain. The auxiliary outlet is located inside of the treatment cell.	A <u>Modular Wetland System</u> is a three chamber treatment cell that utilizes plants, filter media, filter media cartridges, and a perforated underdrain network.
<b>A standard operational plan illustrates the general facility footprint configuration and explains the purpose of each facility component. Operational plans (A and B) are provided in the Standard Operation Manual.</b>		

See Appendix A for the site specific operational plan.

### Operational Components

The facility components table (**Table 1**) has been provided to highlight the applicable components for this facility. The component is in use when the box contains an “x” (e.g.  ).

The Standard Operation Manual for Water Quality Planters (implemented April 2018) outlines facility operation, typical footprint configuration, and component definitions and details. A link to the manual is attached to the feature marker in TransGIS.

<https://gis.odot.state.or.us/TransGIS/>



## Maintenance Items

Operational components marked in **Table 1** should be inspected and maintained according to Section 7. Each facility component is defined and detailed in the Standard Operation Manual using the associated ID number indicated below.

Table 1: Facility Components		ID #
<b>Facility Inlet</b>		
Inlet Grate	<input type="checkbox"/>	P1
Curb Inlet	<input checked="" type="checkbox"/>	P2
Sidewalk Chute	<input type="checkbox"/>	P3
Bypass Inlet	<input type="checkbox"/>	P4
<b>Treatment</b>		
Plants (Tree or Shrub)	<input checked="" type="checkbox"/>	P5
Grass	<input checked="" type="checkbox"/>	P6
Water Quality Mix	<input checked="" type="checkbox"/>	P7
Filter Media Cartridge	<input type="checkbox"/>	P8
<b>Planter Components</b>		
Perforated Pipe	<input checked="" type="checkbox"/>	P9
Outlet Grate	<input checked="" type="checkbox"/>	P10
<b>Outfall Type</b>		
Waterbody (Creek/Lake/Ocean)	<input type="checkbox"/>	P11
Ditch	<input type="checkbox"/>	P12
Storm Drain System	<input checked="" type="checkbox"/>	P13

## 7. Maintenance

### Maintenance Frequency/Maintain Records

- a. Full inspection annually. Preferably prior to the rainy season.
- b. Clean and maintain as necessary. Refer to Activity 125 for conditions when maintenance is needed.
- c. Keep a record of inspections, maintenance, and repairs.

### Maintenance Guide/Maintenance Actions

The ODOT Routine Road Maintenance Water Quality and Habitat Guide (the *Blue Book*) outlines the standard maintenance actions for water quality facilities under Activity 125.

There are standard maintenance tables for standard ODOT designs. The maintenance tables describe the maintenance component, the defect or problem, the condition when

maintenance is needed, and the recommended maintenance to correct the problem. Use the following tables to maintain these water quality planters:

- Table 1 (General Maintenance): Contains general maintenance and inspection guidelines that are applicable to all ODOT water quality facilities. Maintenance of inlets, outlets, trash removal and noxious weeds is recommended seasonally.
- Table 3 (Maintenance of Water Quality or Biofiltration Swales): Contains maintenance information for swales. The planted area of these planters should be maintained as described for the bottom and sides of swales, by using equipment other than mowers to control plant height. Replant if needed with plants from the original plans, or as recommended by ODOT landscaping and stormwater staff.

The *Blue Book* can be viewed at the following website:

[http://www.oregon.gov/ODOT/Maintenance/Documents/blue\\_book.pdf](http://www.oregon.gov/ODOT/Maintenance/Documents/blue_book.pdf)

## 8. Limitations

Vactors may be used at the inlet, outlet, and grated areas. No heavy equipment may be used in the planted areas.

## 9. Waste Material Handling

Material removed from the facility is defined as waste by the Department of Environmental Quality (DEQ). Refer to the road waste section of the ODOT Maintenance Yard Environmental Management System (EMS) Policy and Procedures Manual for disposal options:

<http://www.oregon.gov/ODOT/HWY/OOM/pages/ems.aspx>

Contact any of the following for more detailed information about management of waste materials found on site:

ODOT Clean Water Unit	(503) 986-3008
ODOT Statewide Hazmat Coordinator	(503) 667-7442
ODOT Region 1 Hazmat Coordinator	(503) 731-8290
ODOT Region 2 Hazmat Coordinator	(503) 986-2647
ODOT Region 3 Hazmat Coordinator	(541) 957-3594
ODOT Region 4 Hazmat Coordinator	(541) 388-6186
ODOT Region 5 Hazmat Coordinator	(541) 963-1590
ODEQ Northwest Region Office	(503) 229-5263



## **A Appendix A – Site Specific Operational Plan**

### **Contents:**

**Operational Plan: DFI D00938, D00939**

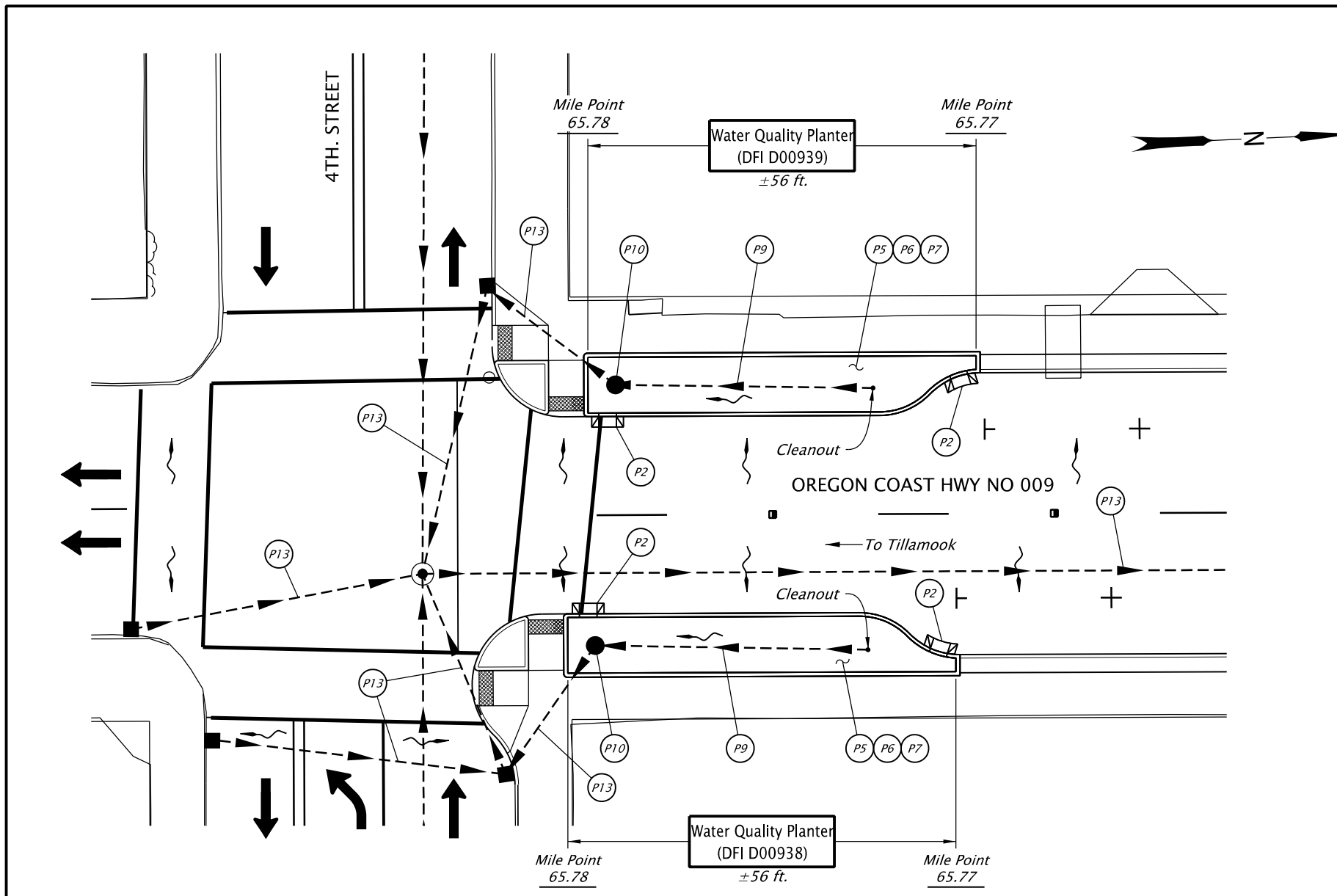

- LEGEND:**
- Photo Location / Direction
  - Facility Component (see table 1 in O&M Manual)
  - Manhole
  - Bioretention Point Outlet
  - Storm Pipe (Facility)
  - Conveyance Direction
  - Pavement/Facility Flow Path
  - Traffic Flow Direction

**INDEX OF WATER QUALITY PLANTERS**

DFI	MILE POINT		LENGTH ±(FT.)	WIDTH ±(FT.) Varies	"H" (DEPTH) ±(IN.)
	BEGIN	END			
D00938	65.77	65.78	56	2-8	12
D00939	65.77	65.78	56	2-8	12

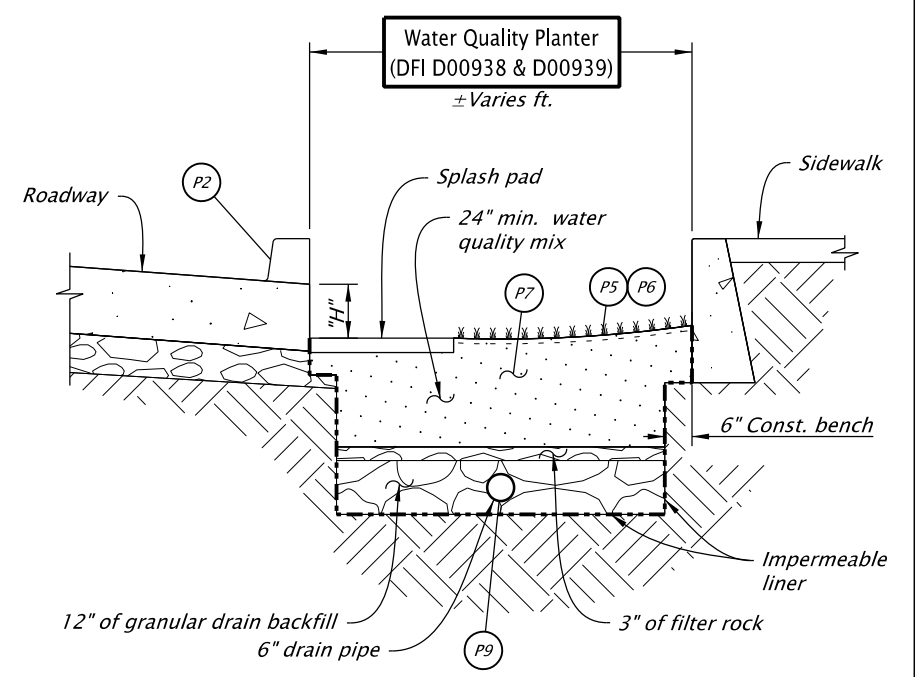

**TYPICAL SECTION WITH CURB INLET**  
N.T.S.

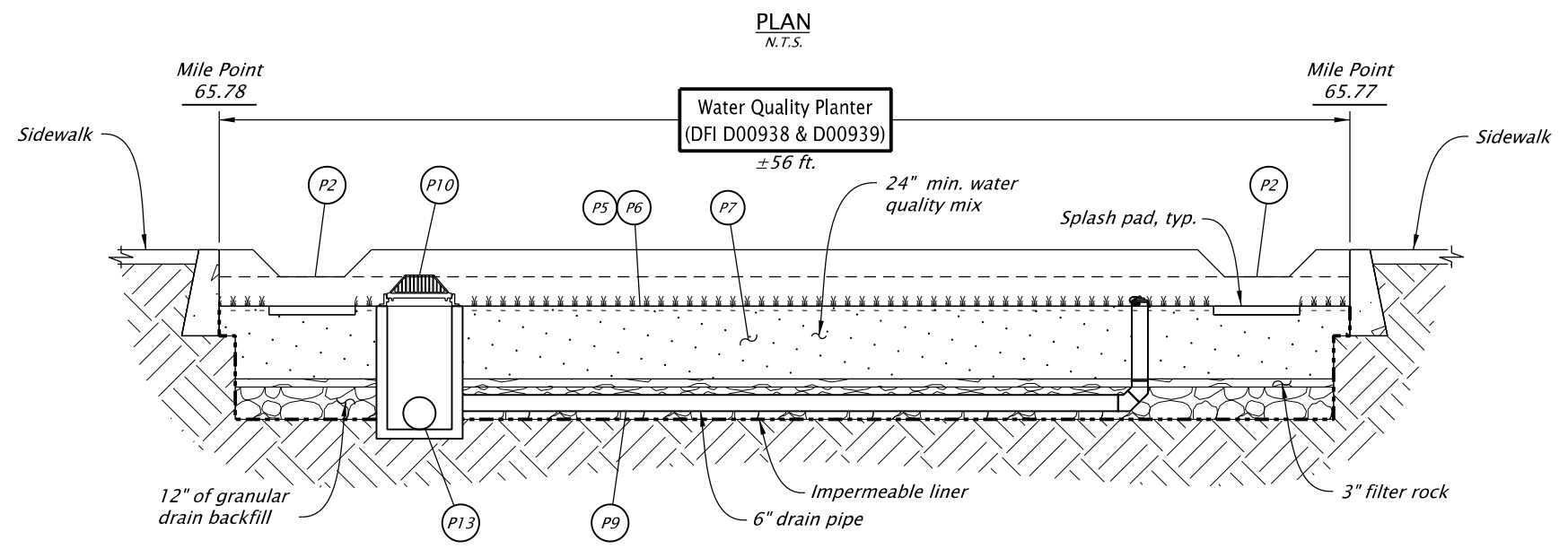

**TYPICAL ELEVATION WITH CURB INLET**  
N.T.S.



Prepared By: Chris Carman

Drafted By: Michael Skelton

**DFI D00938 and D00939**  
**MAINTENANCE DISTRICT 1 HWY 009**  
**WATER QUALITY PLANTERS**  
OREGON COAST HWY MP 65.77 - 65.78  
TILLAMOOK COUNTY

## **Appendix B – Project Contract Plans**

### **Contents:**

**Site Specific Subset of Project Contract Plan 49V-060**

INDEX OF SHEETS	
SHEET NO.	DESCRIPTION
1	Title Sheet
1A, 1A-2	Index Of Sheets Cont.
1A-3	Std. Drg. Nos.
1B	Plan Sheet Layout

STATE OF OREGON  
DEPARTMENT OF TRANSPORTATION

PLANS FOR PROPOSED PROJECT

GRADING, DRAINAGE, STRUCTURES, PAVING, SIGNING, ILLUMINATION, SIGNALS, & ROADSIDE DEVELOPMENT

**US101 @ OR6 (TILLAMOOK) SEC.**  
**OREGON COAST HWY. & WILSON RIVER HWY.**

TILLAMOOK COUNTY

MAY 2016

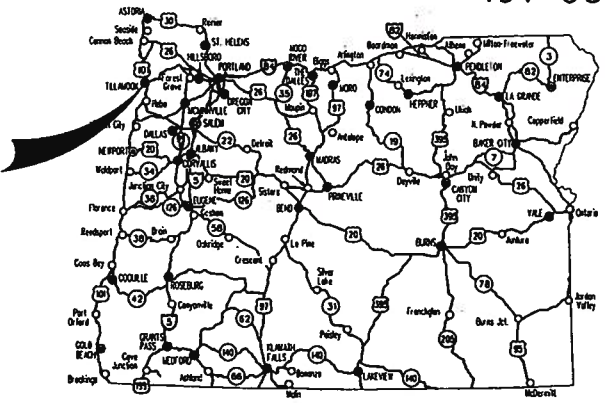

Overall Length Of Project - 0.4 Miles

**ATTENTION:**  
Oregon Law Requires You To Follow Rules Adopted By The Oregon Utility Notification Center. Those Rules Are Set Forth In OAR 952-001-0010 Through OAR 952-001-0090. You May Obtain Copies Of The Rules By Calling The Center. (Note: The Telephone Number For The Oregon Utility Center Is (503) 232-1987.)



OREGON TRANSPORTATION COMMISSION	
Tammy Boney	CHAIR
David Lohman	COMMISSIONER
Susan Morgan	COMMISSIONER
Alando Simpson	COMMISSIONER
Sean O'Hollaren	COMMISSIONER
Matthew L. Garrett	DIRECTOR OF TRANSPORTATION

PLANS PREPARED FOR OREGON DEPARTMENT OF TRANSPORTATION



These plans were developed using ODOT design standards. Exceptions to these standards, if any, have been submitted and approved by the ODOT Chief Engineer or their delegated authority.

Approving Authority: *Jeff W. Olson* 3/3/16  
Signature & date

Jeff W. Olson, Principal

*Joseph J. Spurr* 3/22/16  
Print name and title  
Concurrence by ODOT Chief Engineer

**US101 @ OR6 (TILLAMOOK) SEC.**  
**OREGON COAST HWY. & WILSON RIVER HWY.**  
TILLAMOOK COUNTY

FEDERAL HIGHWAY ADMINISTRATION	PROJECT NUMBER	SHEET NO.
OREGON DIVISION	JTA-S009(473)	1

END OF PROJECT

JTA-S009(473)

STA. "L" 412+03.00 (M.P. 65.41)

BEGINNING OF PROJECT

JTA-S009(473)

STA. "B" 200+00.00

BEGINNING OF PROJECT

JTA-S009(473)

STA. "WR" 9+25.00 (M.P. 0.11)

END OF PROJECT

JTA-S009(473)

STA. "WR" 17+62.63 (M.P. 9.07)

BEGINNING OF PROJECT

JTA-S009(473)

STA. "M" 191+93.00 (M.P. 65.78)

BEGINNING OF PROJECT

JTA-S009(473)

STA. "P" 192+68.00 (M.P. 65.81)

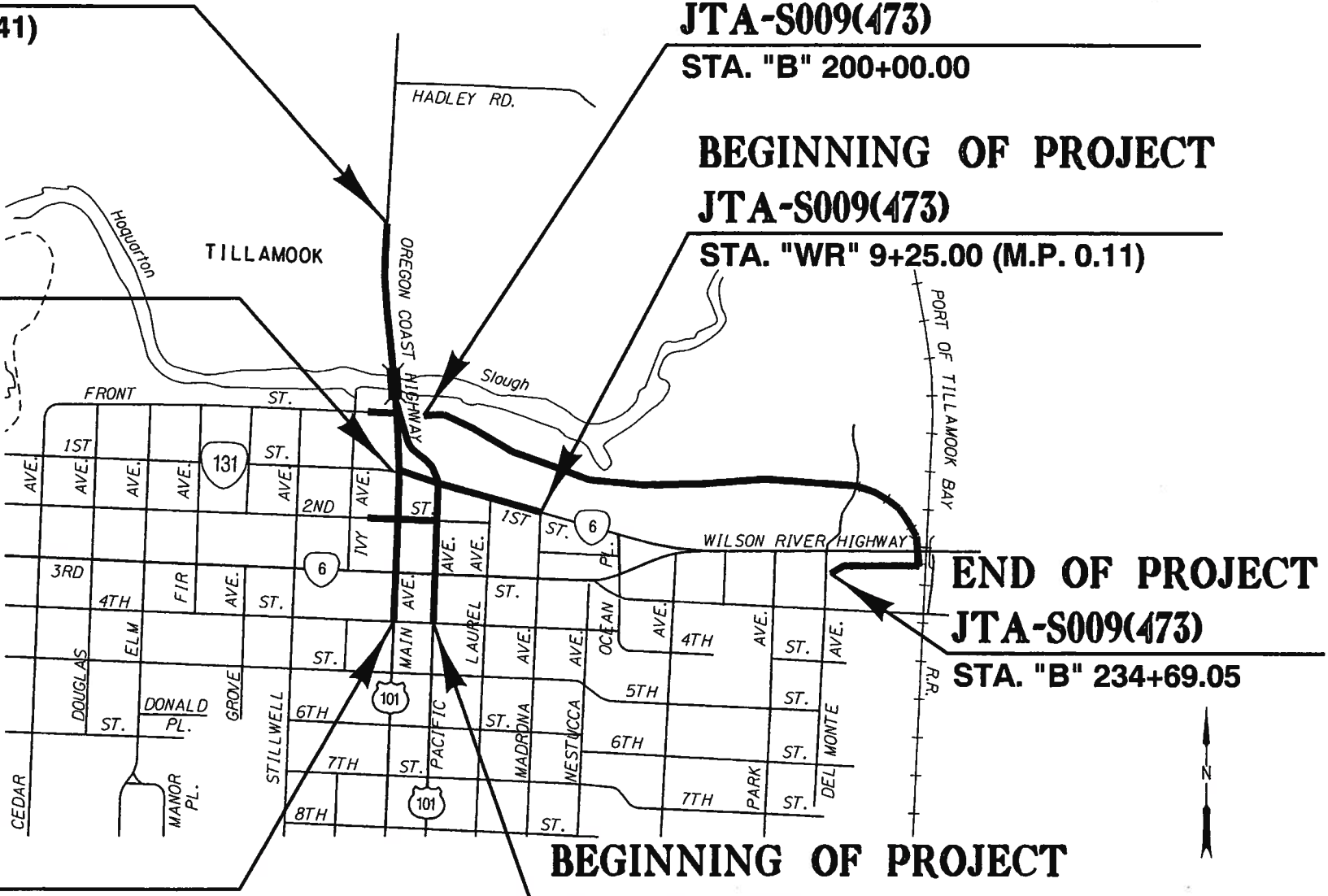

T. I. S., R. 9 W., W.M.



Sec. 30, T. 1 S, R. 9 W, W.M.  
TILLAMOOK

49V-060

BEGIN WORK AREA  
STA. "M" 191+93

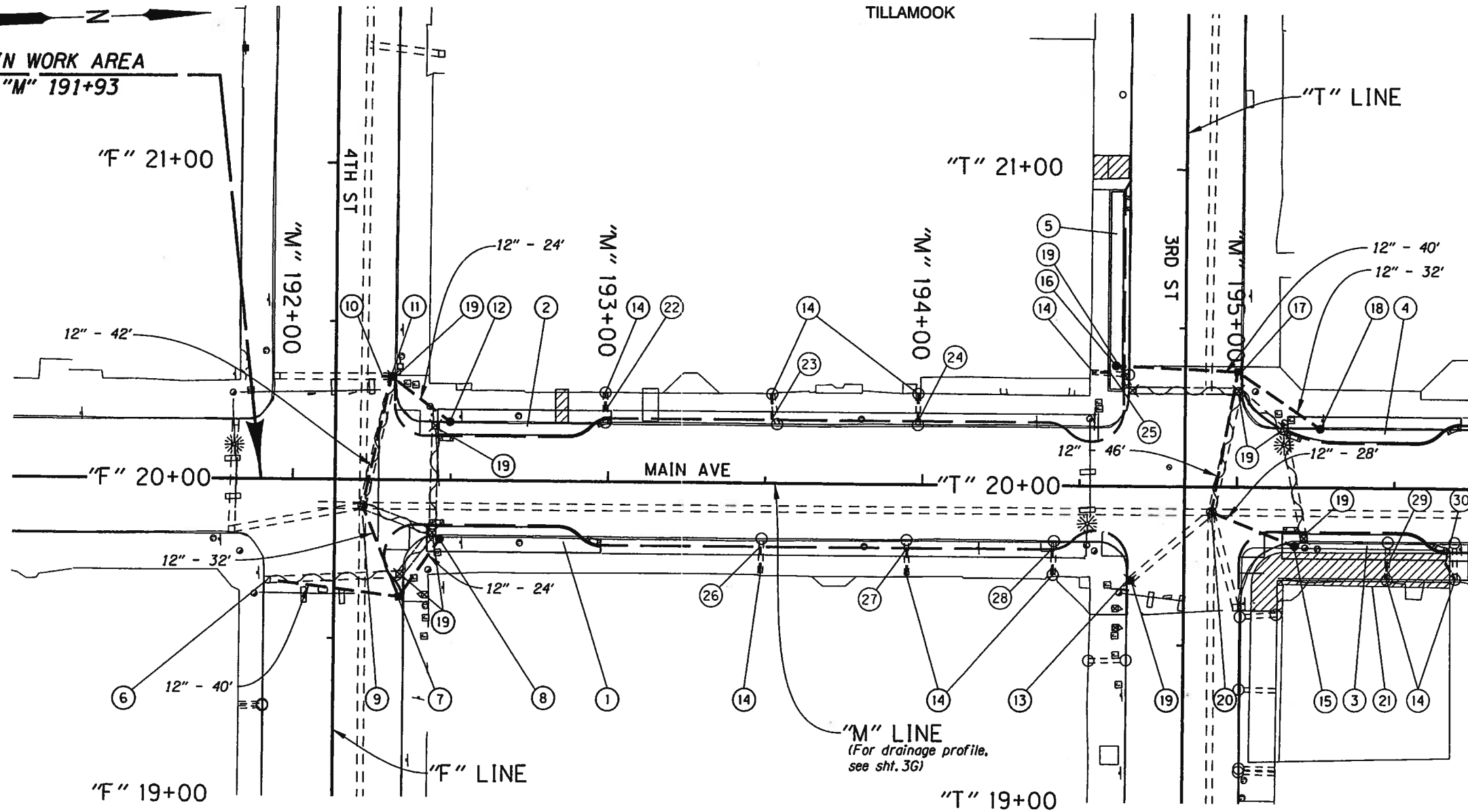

- ① Sta. "M" 192+42.16 to Sta. "M" 192+98.44, Rt. Const. Bioretention Pond D00938 - 397 Sq. Ft. (For details, see shts. GJ thru GJ-16)
- ② Sta. "M" 192+45.18 to Sta. "M" 193+01.46, Lt. Const. Bioretention Pond D00939 - 397 Sq. Ft. (For details, see shts. GJ thru GJ-16)
- ③ Sta. "M" 195+13.92 to Sta. "M" 195+67.50, Rt. Const. Bioretention Pond D00935 - 375 Sq. Ft. (For details, see shts. GJ thru GJ-16)
- ④ Sta. "M" 195+15.36 to Sta. "M" 195+71.68, Lt. Const. Bioretention Pond D00936 - 378 Sq. Ft. (For details, see shts. GJ thru GJ-16)
- ⑤ Sta. "T" 20+93.61 to Sta. "T" 20+30.00, Lt. Const. Bioretention Pond D00937 - 245 Sq. Ft. (For details, see shts. GJ thru GJ-16)
- ⑥ Sta. "M" 191+93.24, 31.80 Rt. Connect to extg. inlet I.E.out= 20.10 (N)
- ⑦ Sta. "M" 192+34.89, 36.59' Rt. Const. type G-2 inlet with sump. Rim 24.60  
I.E.in= 20.33 (12" NW)  
I.E.in= 19.88 (12" S)  
I.E.out= 19.88 (12" W)  
(See drg. no. RD364)  
Inst. 12" storm sew. pipe - 64' 5' depth
- ⑧ Sta. "M" 192+46.66, 18.50' Rt. Const. beehive inlet  
Rim 24.14  
I.E.out= 20.44 (12" SE)  
(For details, see sht. GJ-12)
- ⑨ Sta. "M" 192+22.21, 8.21' Rt. Connect to extg. MH  
Rim 24.75  
I.E.in= 13.10 (10" E) extg.  
I.E.in= 19.72 (12" NE)  
I.E.in= 19.62 (12" W) extg.  
I.E.in= 19.00 (10" SE) extg.  
I.E.in= 13.10 (15" S) extg.  
I.E.in = 19.62 (12" NW)  
I.E.out= 13.05 (24" N) extg.  
Inst. 12" storm sew. pipe - 74' 5' depth

- Roof drain (Bldg. to curb)
- Sidewalk Vault shown thus:
- Abandon pipe shown thus:
- Remove inlet shown thus:
- Adjust inlet shown thus:
- Remove manhole shown thus:

NOTE:  
1. Field verify elevation call-outs noted with "±".  
2. Utilities in conflict to be relocated by others prior to construction, unless otherwise noted.  
3. Construction notes continued on sht. 3C.

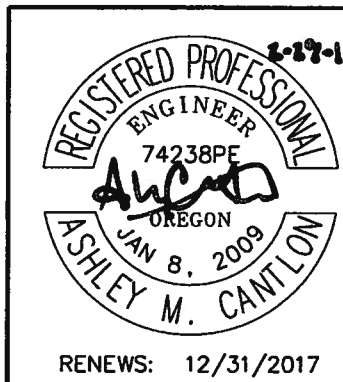

<b>OREGON DEPARTMENT OF TRANSPORTATION</b>	
	Otak Inc. 700 Washington St, Ste. 401 Vancouver, WA 98660 Phone: 360.373.9613 Fax: 360.737.9651
<b>US101 @ OR6 (TILLAMOOK) SEC.</b> OREGON COAST HWY. & WILSON RIVER HWY. TILLAMOOK COUNTY	
Reviewed By - T Kroft Designed By - A Cantlon Drafted By - A Cobb/M McCandless	
<b>DRAINAGE PLAN</b>	SHEET NO. <b>3B</b>

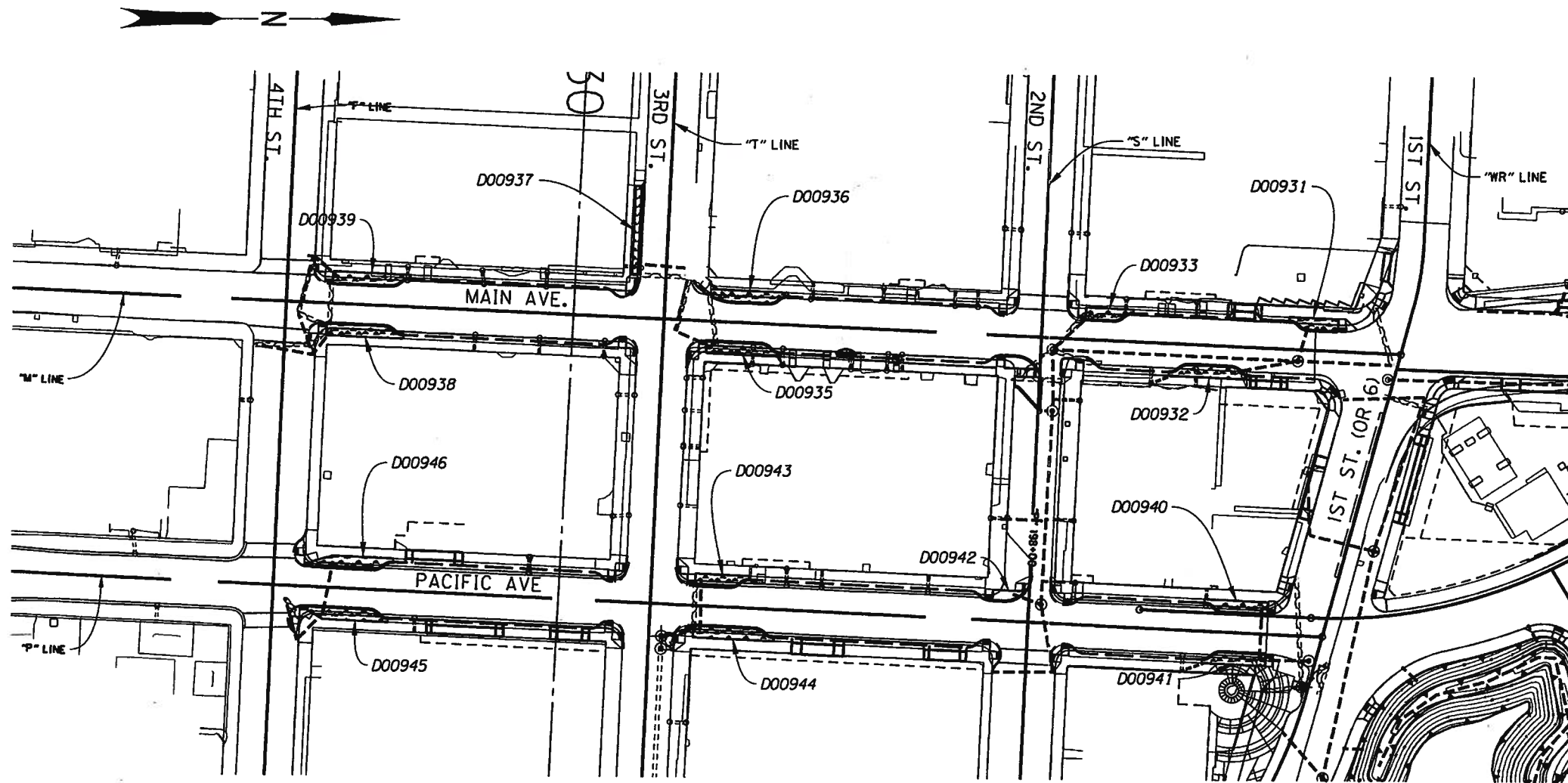

PLAN  
No Scale

**STORMWATER FIELD MARKER TABLE**

FACILITY LOCATION		DFI #	MODIFIED TYPE S2 MARKER LOCATION	
STATION	MP		BEGIN	END
"M" 199+47	65.65	D00931	✓	✓
"M" 198+74	65.67	D00932	✓	✓
"M" 198+01	65.68	D00933	✓	✓
"M" 195+41	65.73	D00935	✓	✓
"M" 195+44	65.73	D00936	✓	✓
"T" 20+62	65.74	D00937	✓	✓
"M" 192+70	65.78	D00938	✓	✓
"M" 192+73	65.78	D00939	✓	✓
"P" 199+48	65.69	D00940	✓	✓
"P" 199+48	65.69	D00941	✓	✓
"P" 197+85	65.72	D00942	✓	✓
"P" 195+80	65.76	D00943	✓	✓
"P" 195+90	65.76	D00944	✓	✓
"P" 193+14	65.81	D00945	✓	✓
"P" 193+16	65.81	D00946	✓	✓

See Drg. No. RD399 for facility marker details.

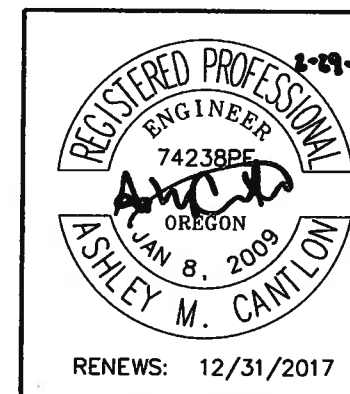

**OREGON DEPARTMENT OF TRANSPORTATION**

**Otak Inc.**  
 700 Washington St, Ste. 401  
 Vancouver, WA 98660  
 Phone: 360.373.9613 Fax: 360.737.9651

**US101 @ OR6 (TILLAMOOK) SEC.**  
 OREGON COAST HWY. & WILSON RIVER HWY.  
 TILLAMOOK COUNTY

Reviewed By - T Kraft  
 Designed By - A Cantlon  
 Drafted By - A Cobb

**WATER QUALITY PLAN**

SHEET NO. GJ



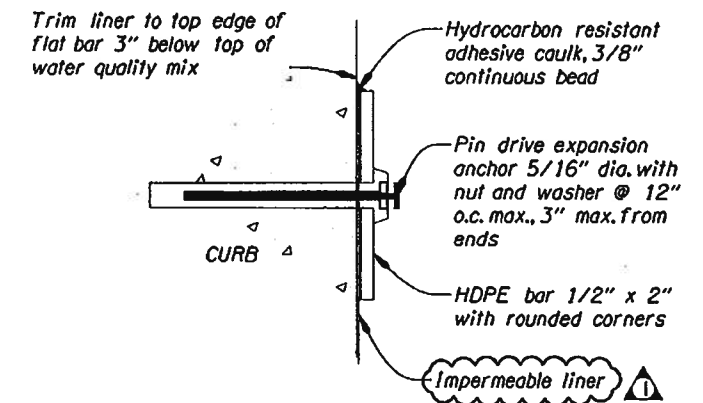
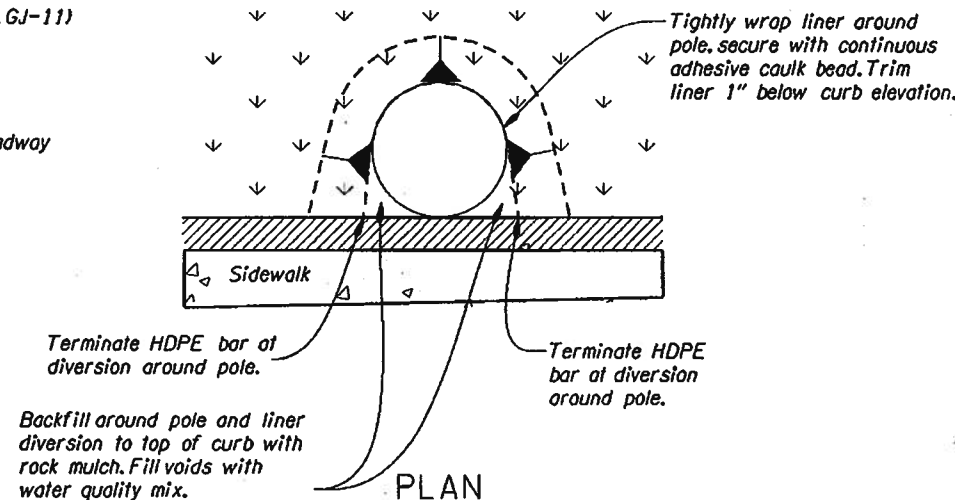
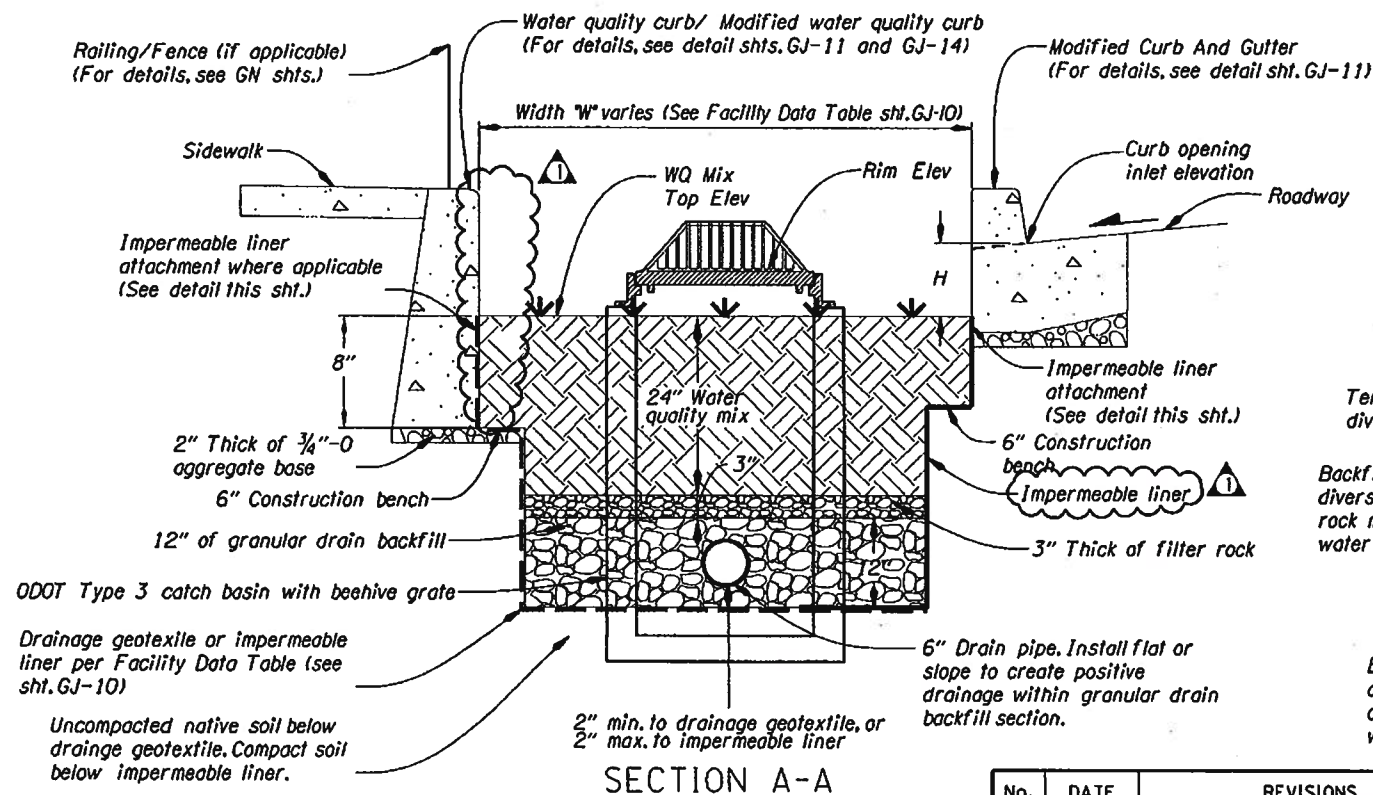
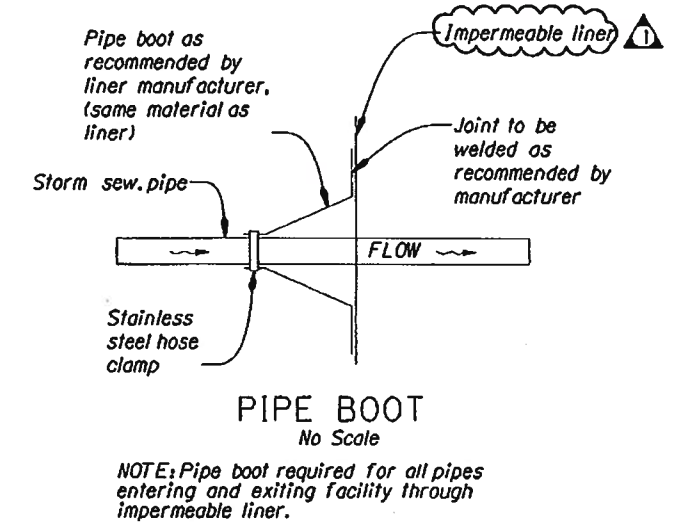
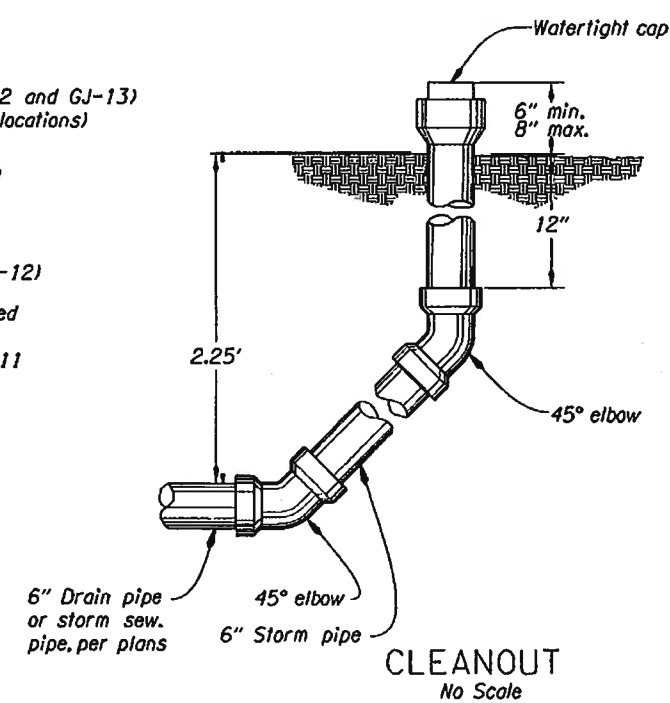
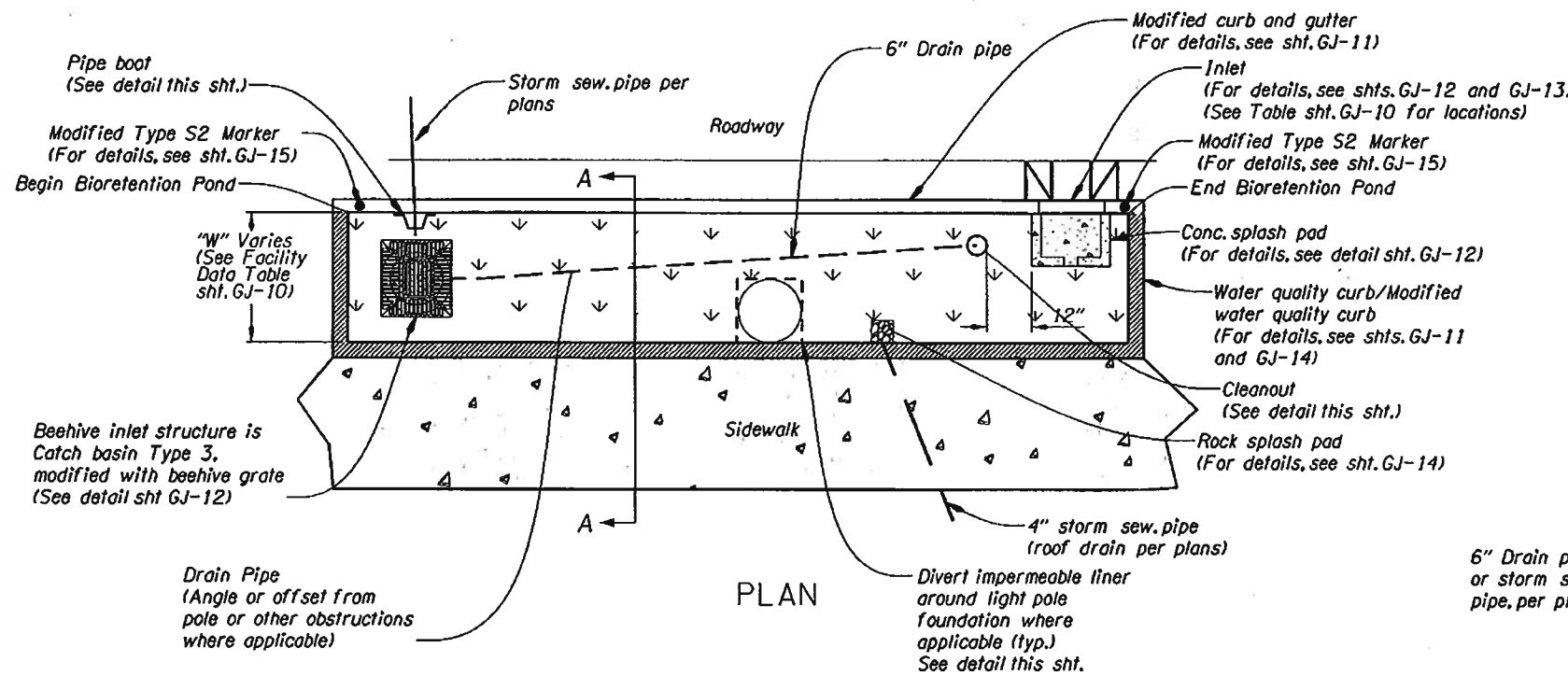

- NOTES:
- Liner to extend from 3 in. below top of top soil to the bottom of excavation.
  - 3 in. of concrete is required on all sides of attachment.

- GENERAL NOTES FOR ALL DETAILS:
- Slope Drain Rock and Filter Rock layers to match bottom slope.
  - Slope drain pipe towards outlet.
  - Install Drain Rock splash pad downstream of check dam, see details sht. GJ-11.
  - Where catch basin structure protrudes through impermeable liner, cut liner in "X" shape to create rectangular hole to match size and shape of structure. Upon installation of catch basin, fold resulting triangular shaped fabric up sides of structure, and secure to structure with adhesive caulk. Backfill holes in liner with compacted topsoil.

No.	DATE	REVISIONS	BY
1	05-03-16	Remove variable "T" reference Remove reference to liner thickness	A.M.C.

**IMPERMEABLE LINER AROUND LIGHT POLE FOUNDATION**  
No Scale

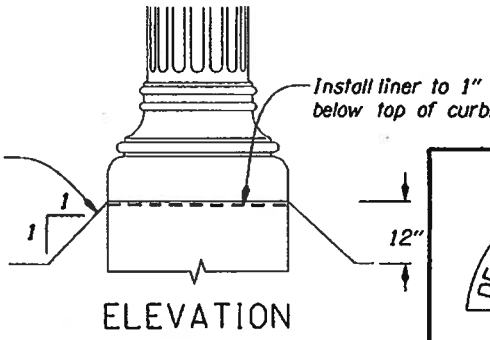

REGISTERED PROFESSIONAL ENGINEER  
74238PE  
ASHLEY M. CANTLON  
OREGON  
JAN 8, 2009  
RENEWS: 12/31/2017

**OREGON DEPARTMENT OF TRANSPORTATION**

otak Otak Inc.  
700 Washington St, Ste. 401  
Vancouver, WA 98660  
Phone: 360.373.9613 Fax: 360.737.9651

US101 @ OR6 (TILLAMOOK) SEC.  
OREGON COAST HWY. & WILSON RIVER HWY.  
TILLAMOOK COUNTY

Reviewed By - T Kraft  
Designed By - A Cantlon  
Drafted By - S Reiter

WATER QUALITY DETAILS

SHEET NO. GJ-9

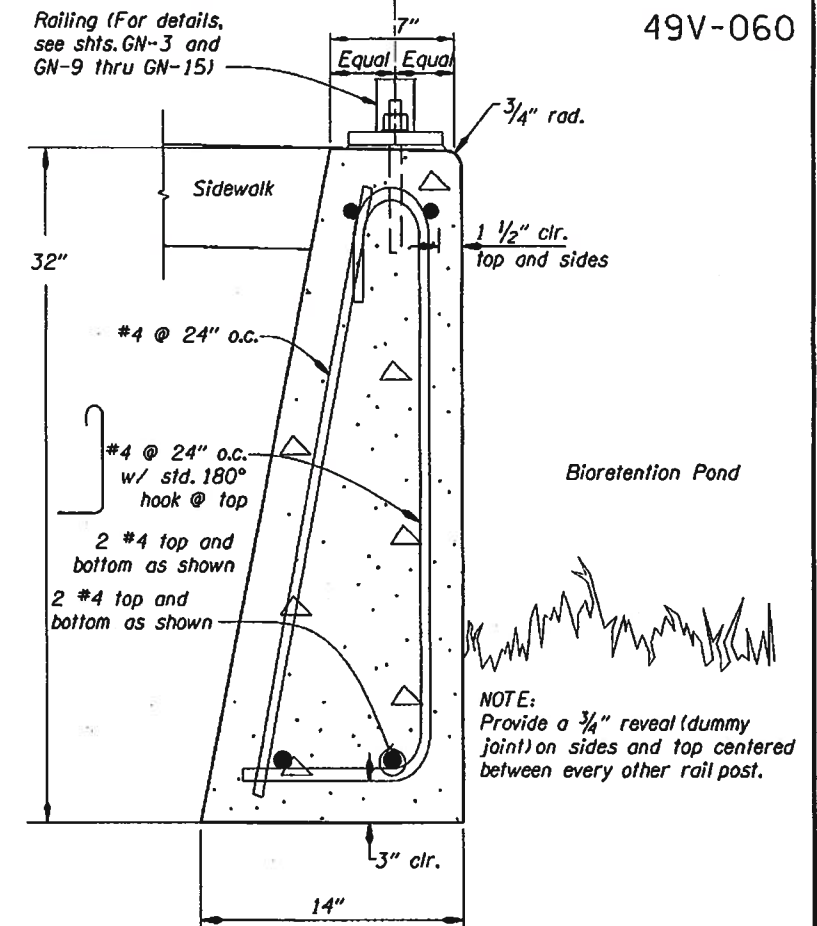
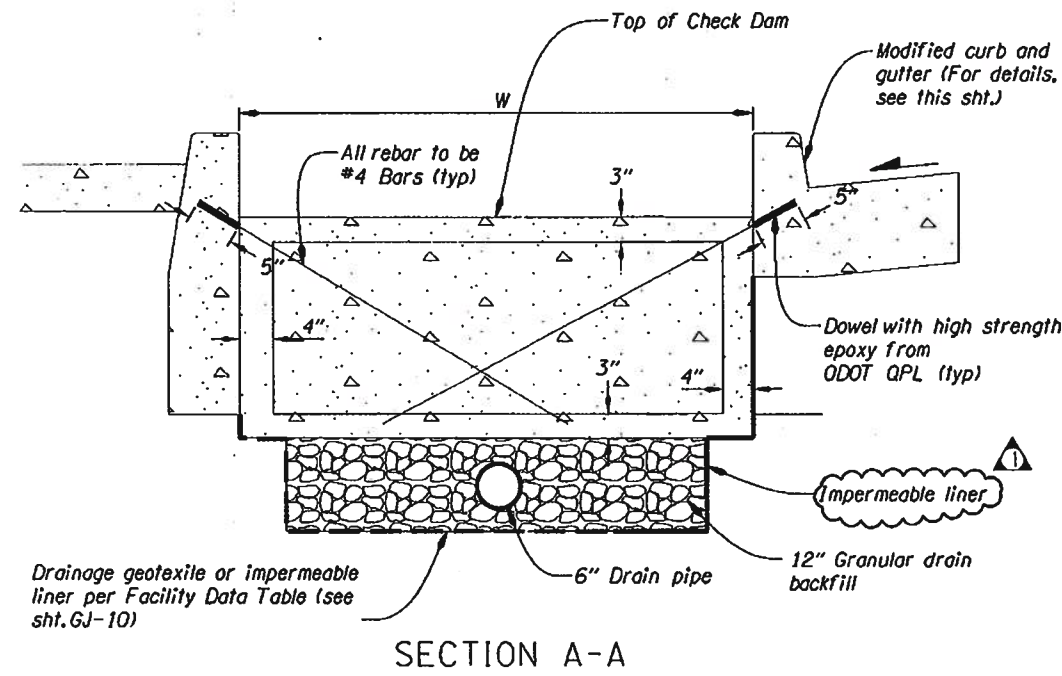
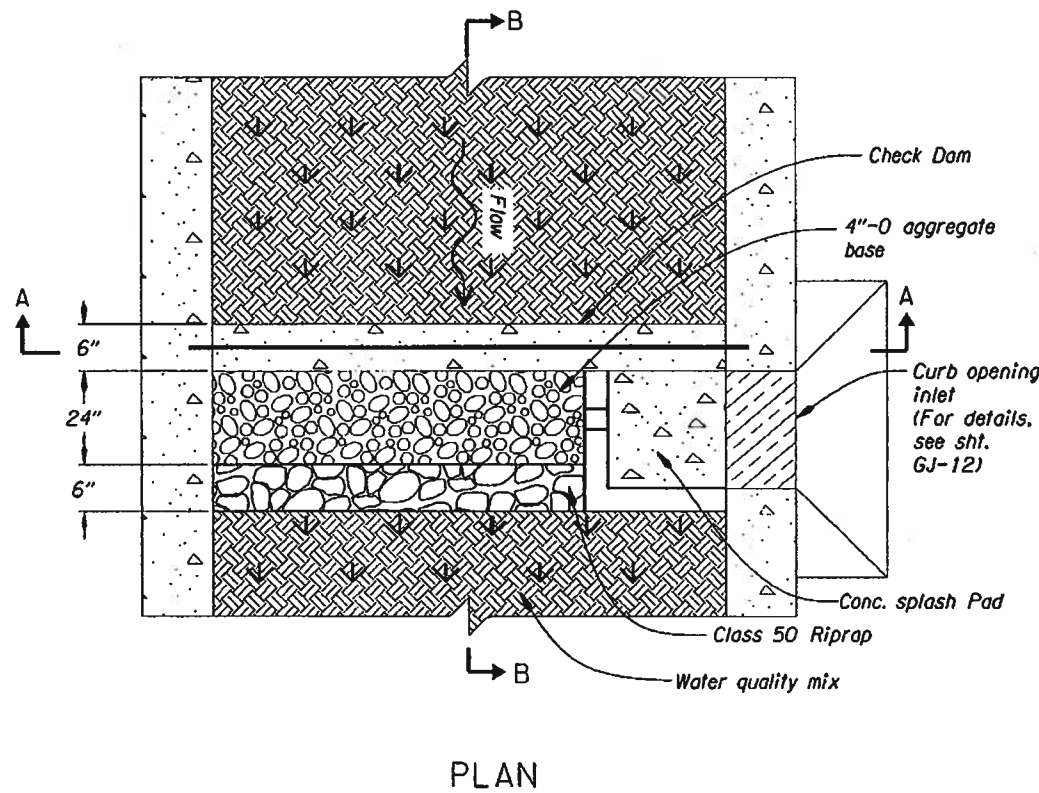

No.	DATE	REVISIONS	BY
1	05-03-16	Remove specified thickness	A.M.C.

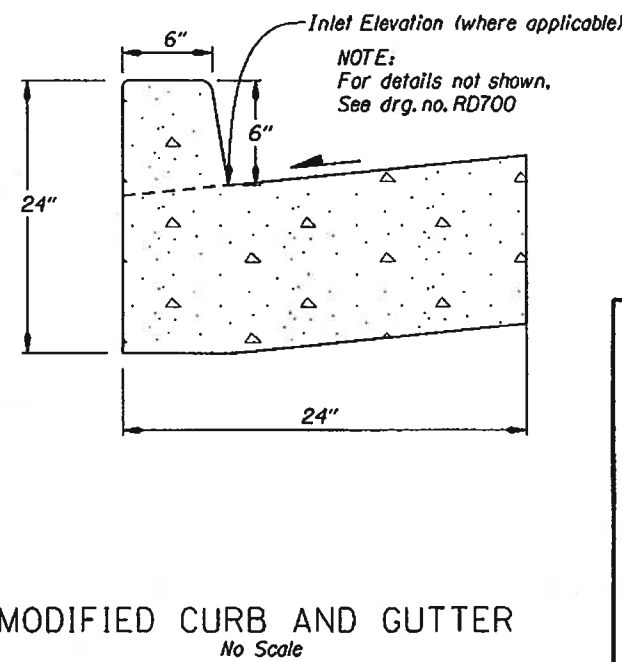
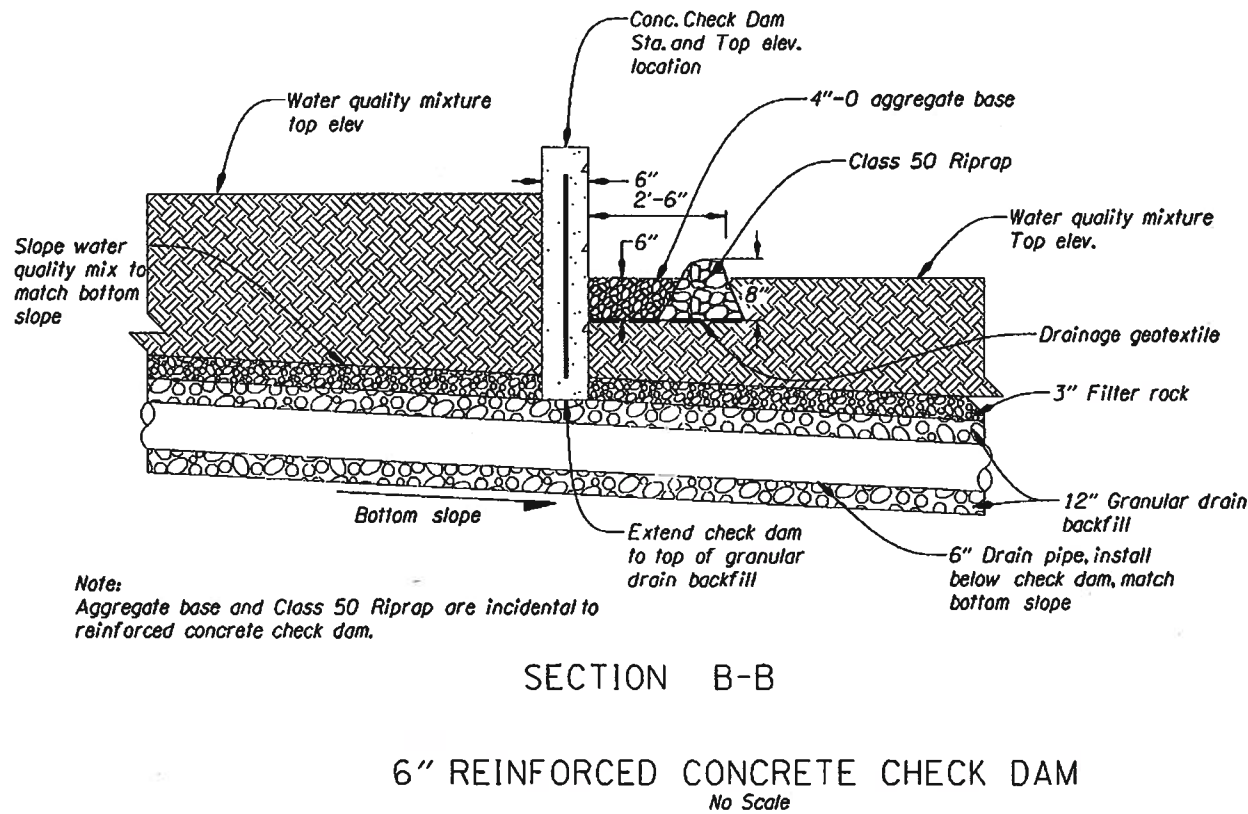

GENERAL NOTES FOR ALL DETAILS:

1. Provide all reinforcing steel according to ASTM A706 or AASHTO M31 (ASTM A615) Grade 60
2. Provide Commercial Grade Class 3300 - 1 1/2", 1", or 3/4" concrete unless noted otherwise.

**OREGON DEPARTMENT OF TRANSPORTATION**

**Otak Inc.**  
HanmiGlobal Partner  
700 Washington St, Ste. 401  
Vancouver, WA 98660  
Phone: 360.373.9613 Fax: 360.737.9651

**US101 @ OR6 (TILLAMOOK) SEC.**  
OREGON COAST HWY. & WILSON RIVER HWY.  
TILLAMOOK COUNTY

Reviewed By - T Kraft  
Designed By - A Cantlon  
Drafted By - S Reiter

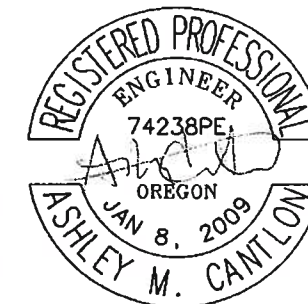

RENEWS: 12/31/2017

**WATER QUALITY DETAILS**

SHEET NO.  
GJ-11



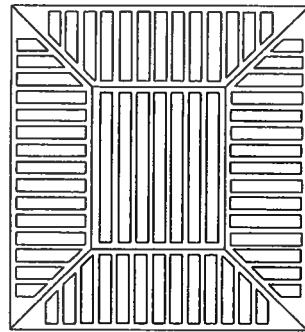

1. Beehive grate shall be model R-4347 or approved equal.
2. Type 3 Frame - Steel (modified) will be required for retrofit of beehive grate.
3. See Drg. No. RD378 for inlet base details.

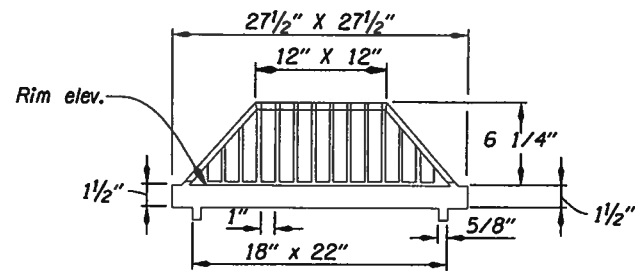

**BEEHIVE INLET**  
No Scale

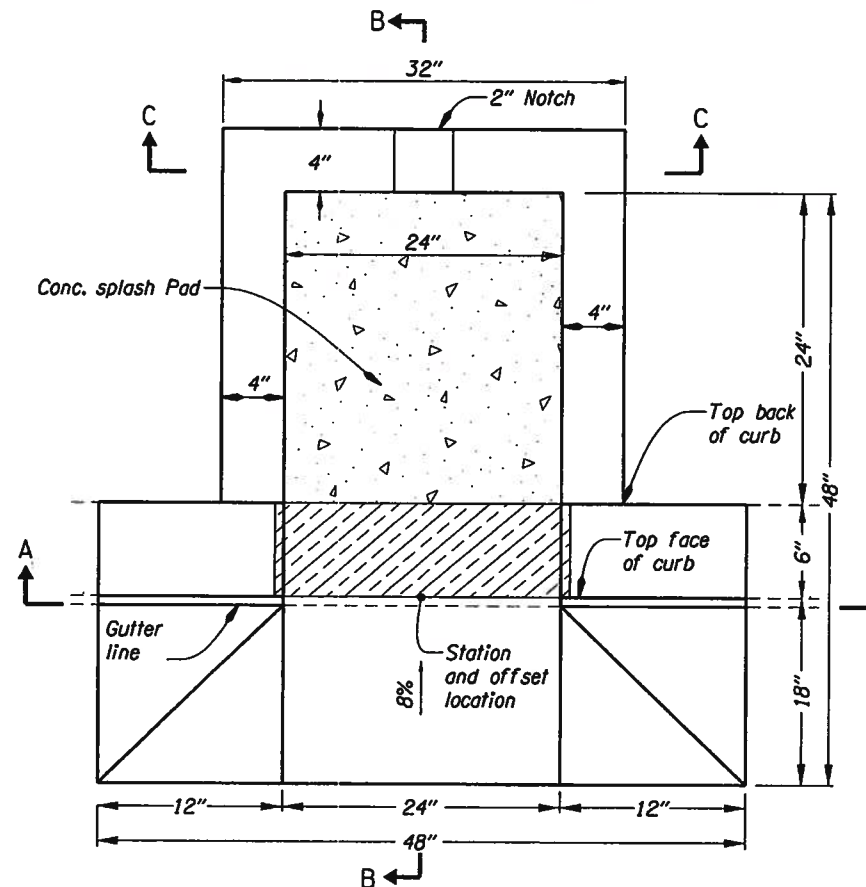

**CURB OPENING INLET PLAN**  
No Scale

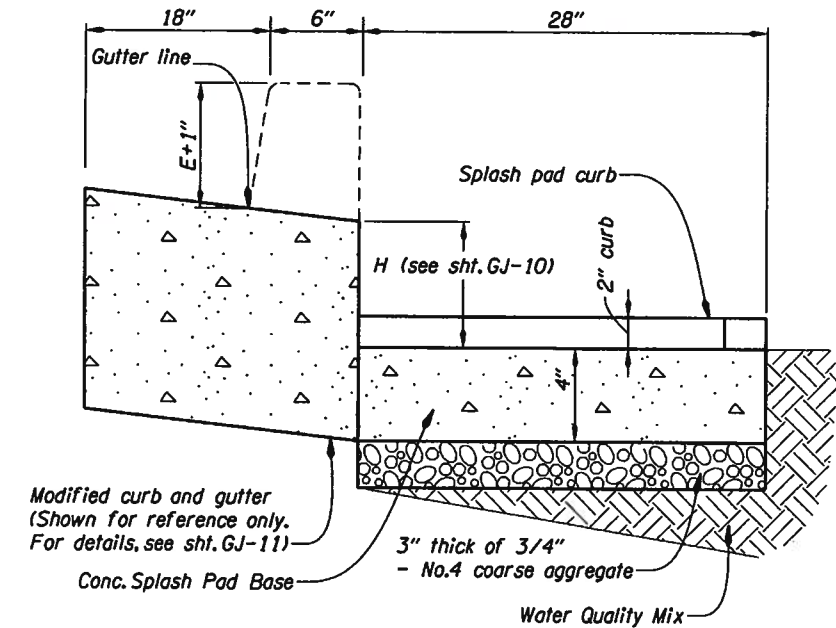

**CURB OPENING INLET SECTION B-B**  
No Scale

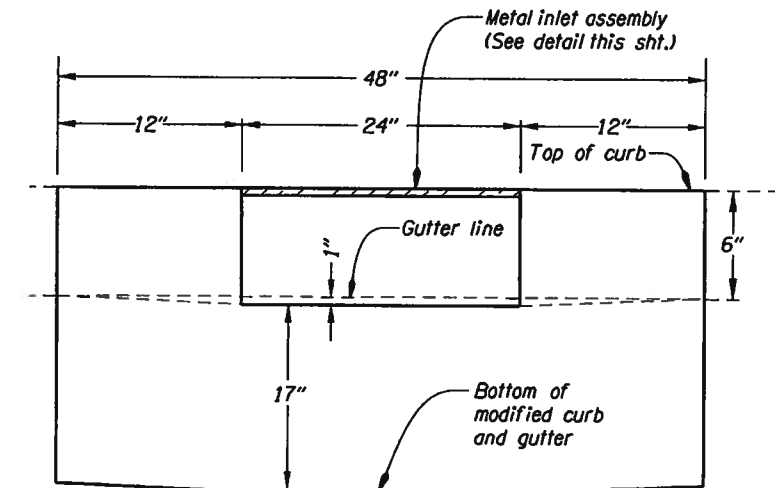

**CURB OPENING INLET SECTION A-A**  
No Scale

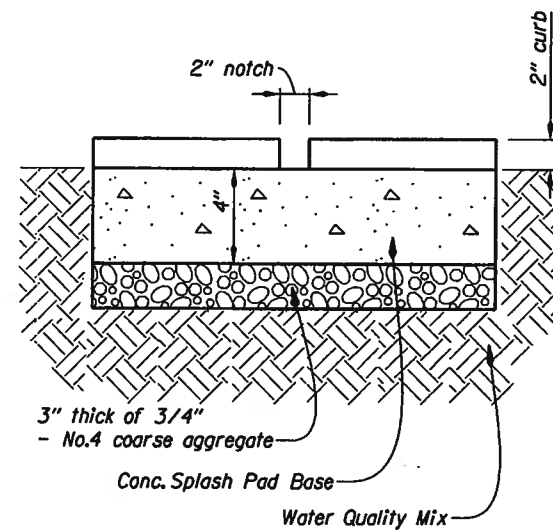

**CURB OPENING INLET SPLASH PAD SECTION C-C**  
No Scale

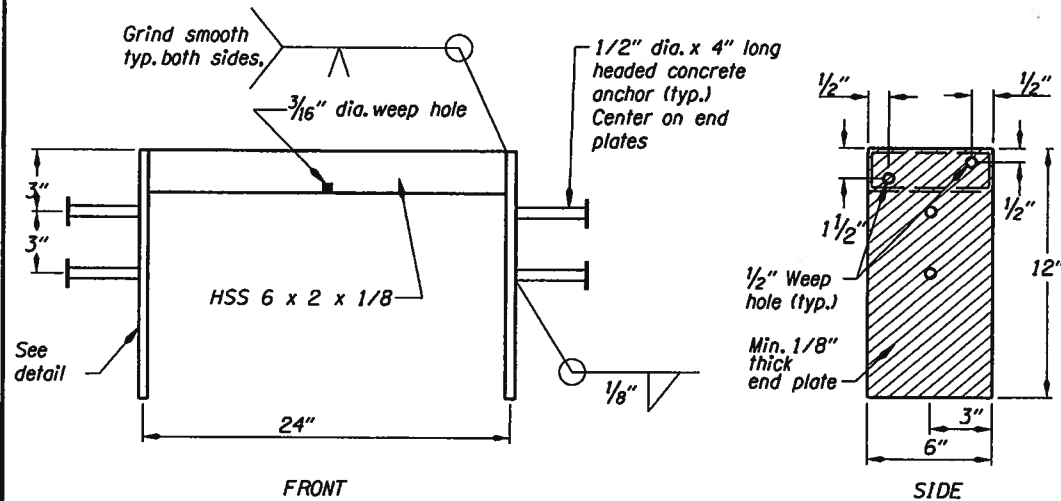

**METAL INLET ASSEMBLY**  
No Scale

**CONSTRUCTION NOTES**

1. Headed concrete anchors shall meet the requirements of ASTM A-108.
2. HSS 6 x 2 x 1/8 Channel shall meet the requirements of ASTM A-500 Grade B.
3. End Plates shall meet the requirements of ASTM A-36.
4. Entire assembly shall be Hot-Dip Galvanized in accordance with ASTM A-123.
5. Single Bevel Groove Weld.

**OREGON DEPARTMENT OF TRANSPORTATION**

**otak** Otak Inc. 700 Washington St. Ste. 401  
Vancouver, WA 98660  
Phone: 360.373.9613 Fax: 360.737.9651

**US101 @ OR6 (TILLAMOOK) SEC.**  
OREGON COAST HWY. & WILSON RIVER HWY.  
TILLAMOOK COUNTY

Reviewed By - T Kraft  
Designed By - A Cantion  
Drafted By - S Reiter

**WATER QUALITY DETAILS** SHEET NO. GJ-12

REGISTERED PROFESSIONAL ENGINEER  
7423800  
ASHLEY M. CANTION  
JAN 8, 2009  
RENEWS: 12/31/2017

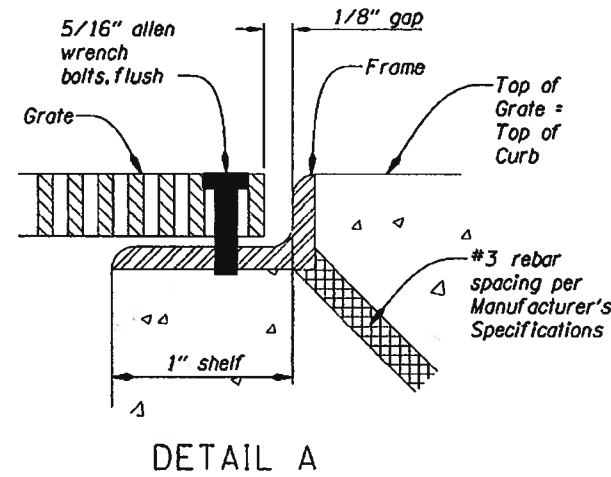
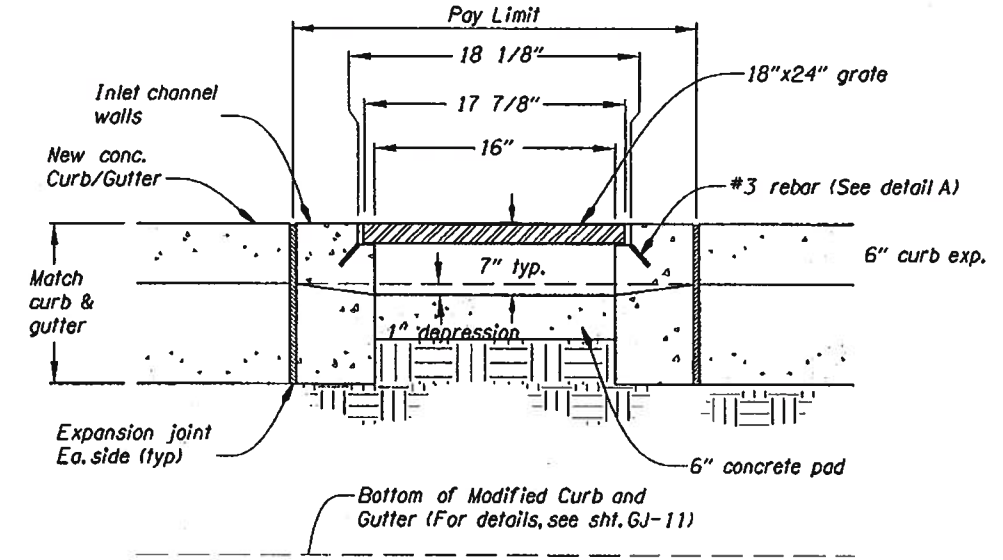
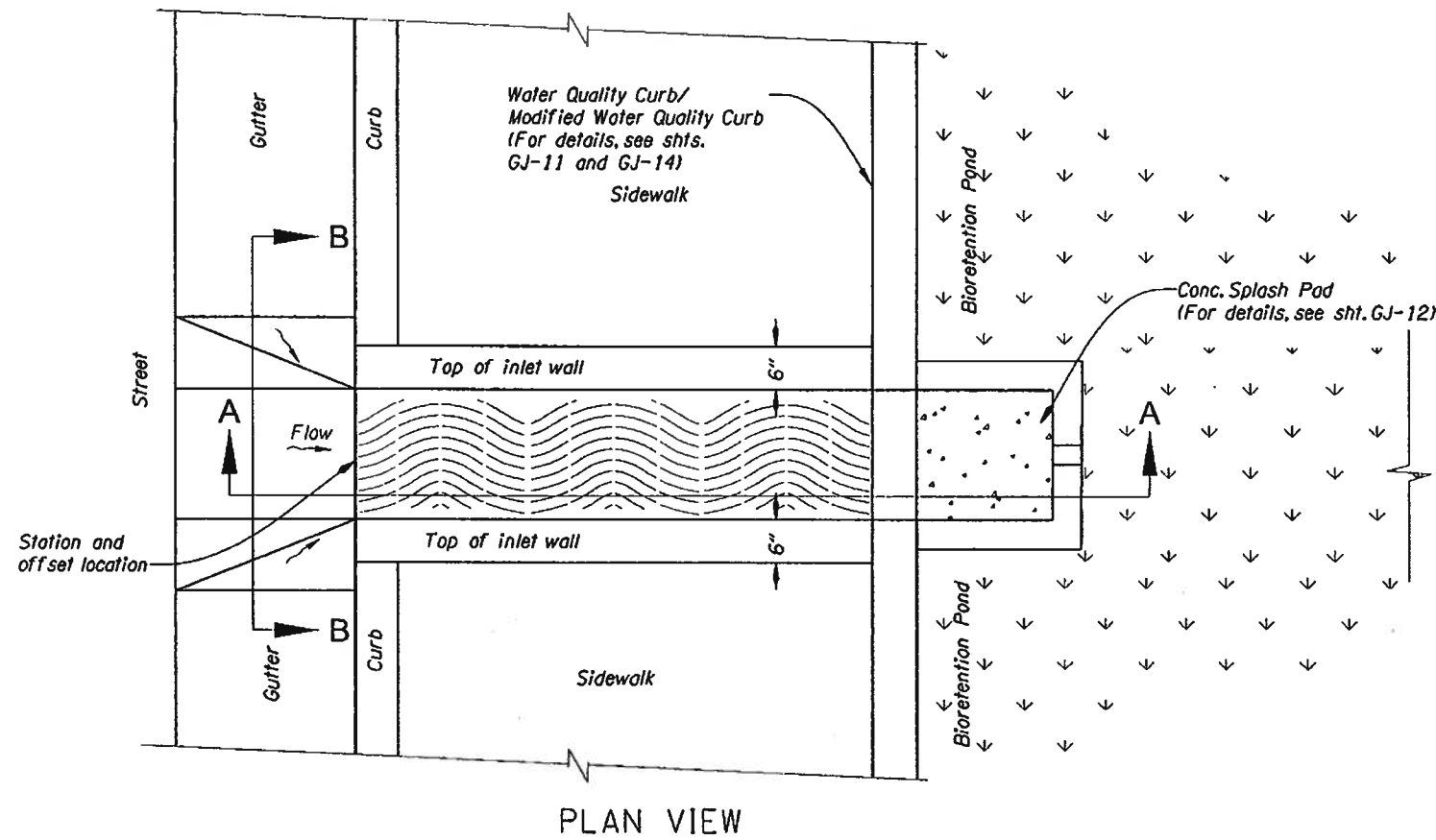

Note: Maximum grate hole width (open) 1/4 inch.  
Grate size 18"x24".  
Cast iron Urban Accessories  
Trench grate and frame.  
Title Wave model or equal.

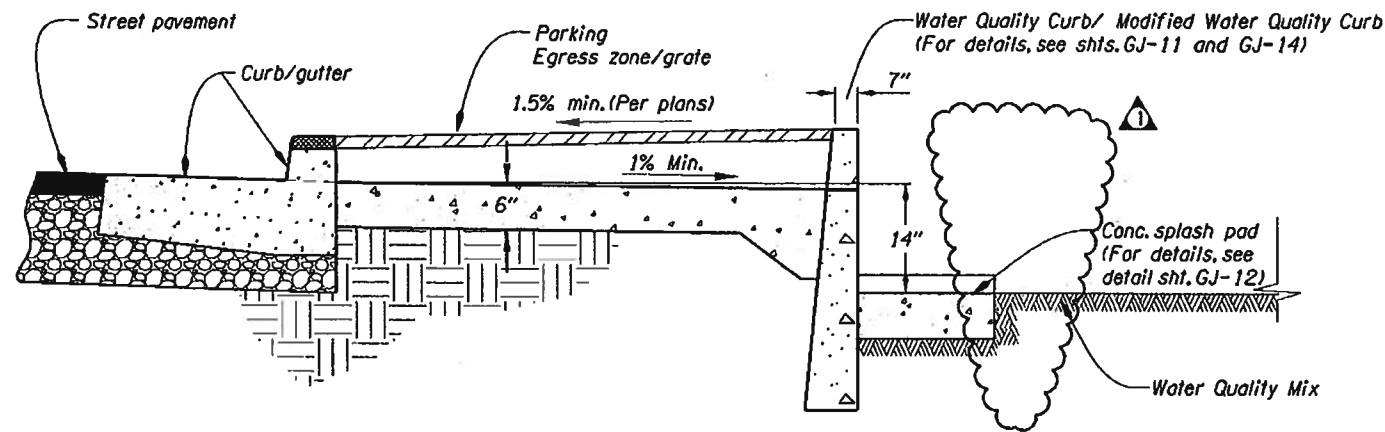

No.	DATE	REVISIONS	BY
1	05-03-16	Remove variable "T" reference	A.M.C.

CONCRETE CHANNEL INLET  
No Scale

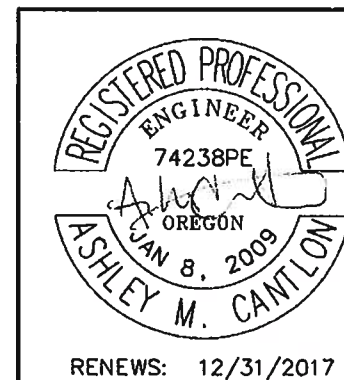

**OREGON DEPARTMENT OF TRANSPORTATION**

**Otak Inc.**  
Honami Global Partner  
700 Washington St, Ste. 401  
Vancouver, WA 98660  
Phone: 360.373.8613 Fax: 360.737.9651

**US101 @ OR6 (TILLAMOOK) SEC.**  
OREGON COAST HWY. & WILSON RIVER HWY.  
TILLAMOOK COUNTY

Reviewed By - T Kraft  
Designed By - A Contion  
Drafted By - S Reiter

**WATER QUALITY DETAILS**

SHEET NO.  
GJ-13

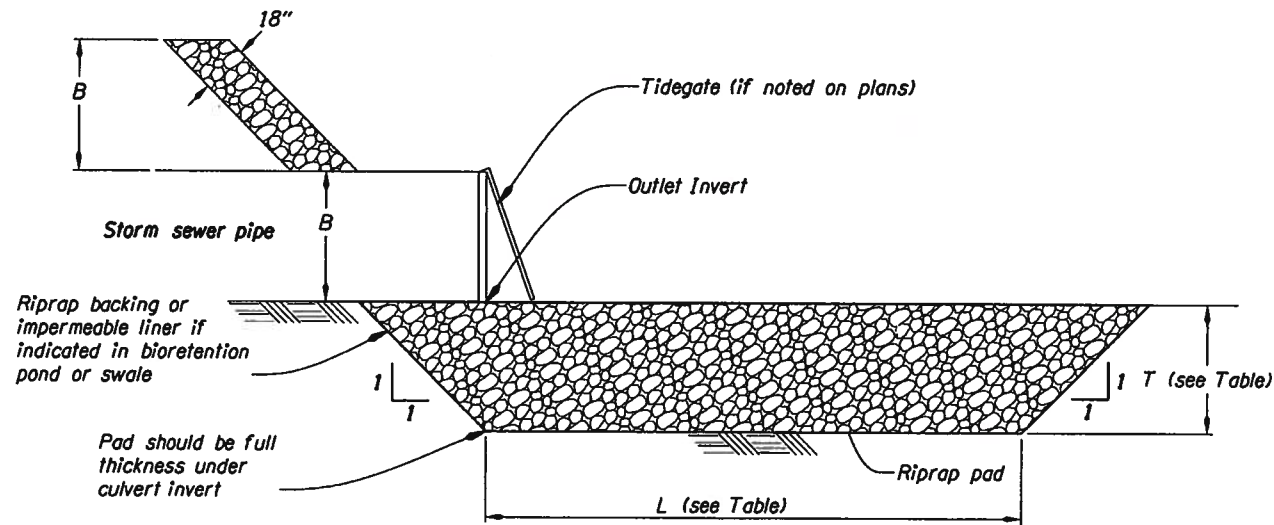

ELEVATION

B = Diameter of storm sew. pipe, ft  
 L = Length of bottom of riprap pad, ft  
 T = Thickness of riprap pad, ft  
 W = Width of top of riprap pad, ft

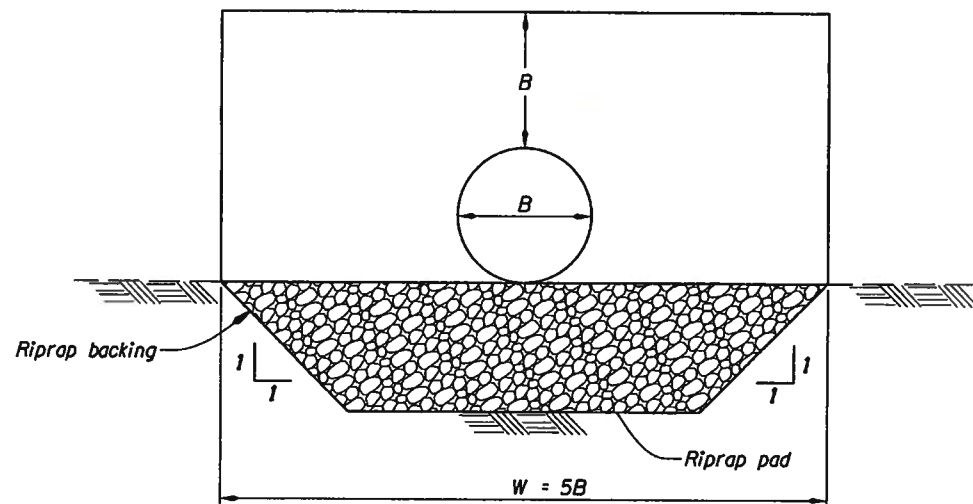

END VIEW

TABLE		
Riprap Class	L* (ft)	T (ft)
50	4B or 1.3	2.3
100	4B or 1.6	3.3

\* Use min. value

- NOTES:  
 1. Do not excavate non-erodible rock in order to place riprap.  
 2. Riprap backing under class 50 riprap shall be riprap geotextile, Type 1.

STORM OUTFALL PROTECTION  
 No Scale

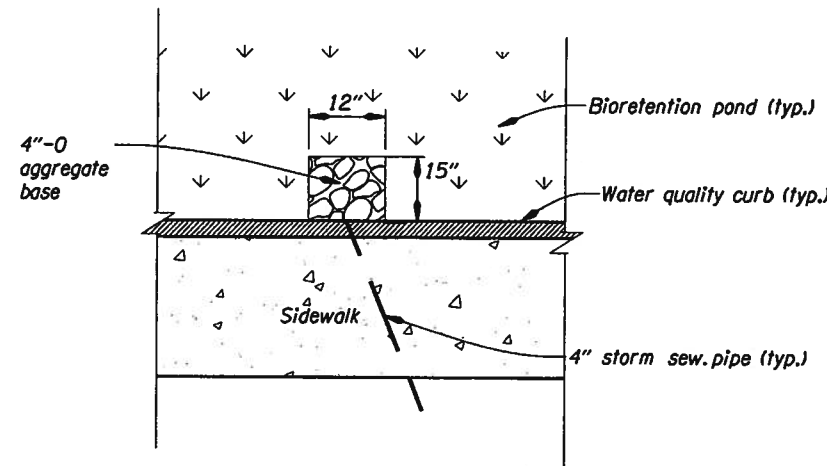

PLAN VIEW

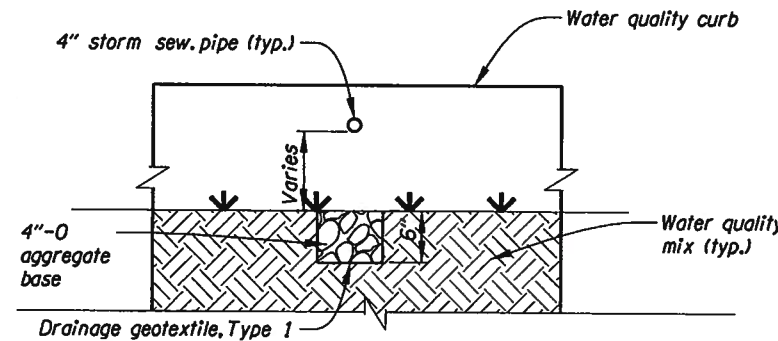

SECTION VIEW

ROCK SPLASH PAD  
 No Scale

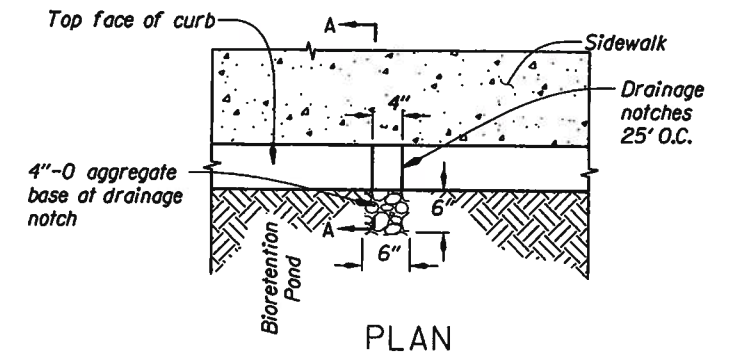

PLAN

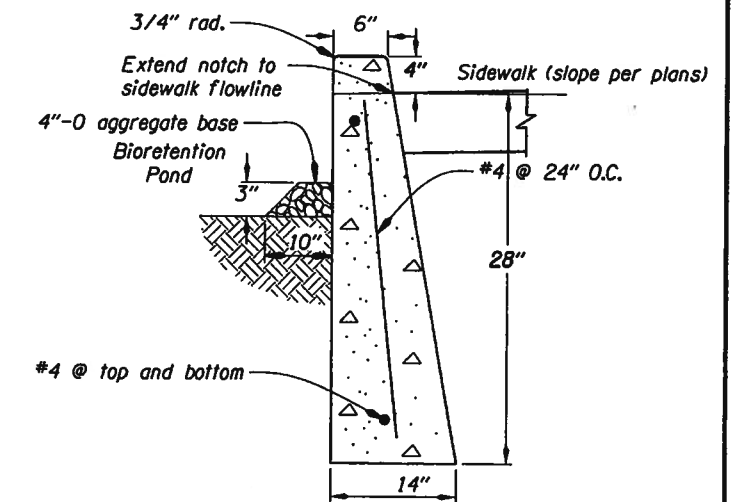

SECTION A-A

- NOTES:  
 1. Provide a 3/4" reveal (dummy joint) on sides and top at 10' O.C. and provide a 1/2" expansion joint at 50' O.C.

MODIFIED WATER QUALITY CURB  
 No Scale

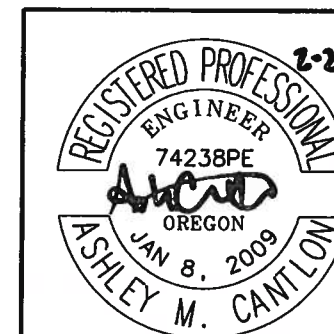

RENEWS: 12/31/2017



Otak Inc.  
 700 Washington St, Ste. 401  
 Vancouver, WA 98660  
 Phone: 360.373.9613 Fax: 360.737.9651

US101 @ OR6 (TILLAMOOK) SEC.  
 OREGON COAST HWY. & WILSON RIVER HWY.  
 TILLAMOOK COUNTY

Reviewed By - T Kroft  
 Designed By - A Cantlon  
 Drafted By - S Reiter

WATER QUALITY DETAILS

SHEET NO.  
 GJ-14