

OPERATION & MAINTENANCE MANUAL

DFI No. : D00670

Facility Type: Bio-Retention Pond

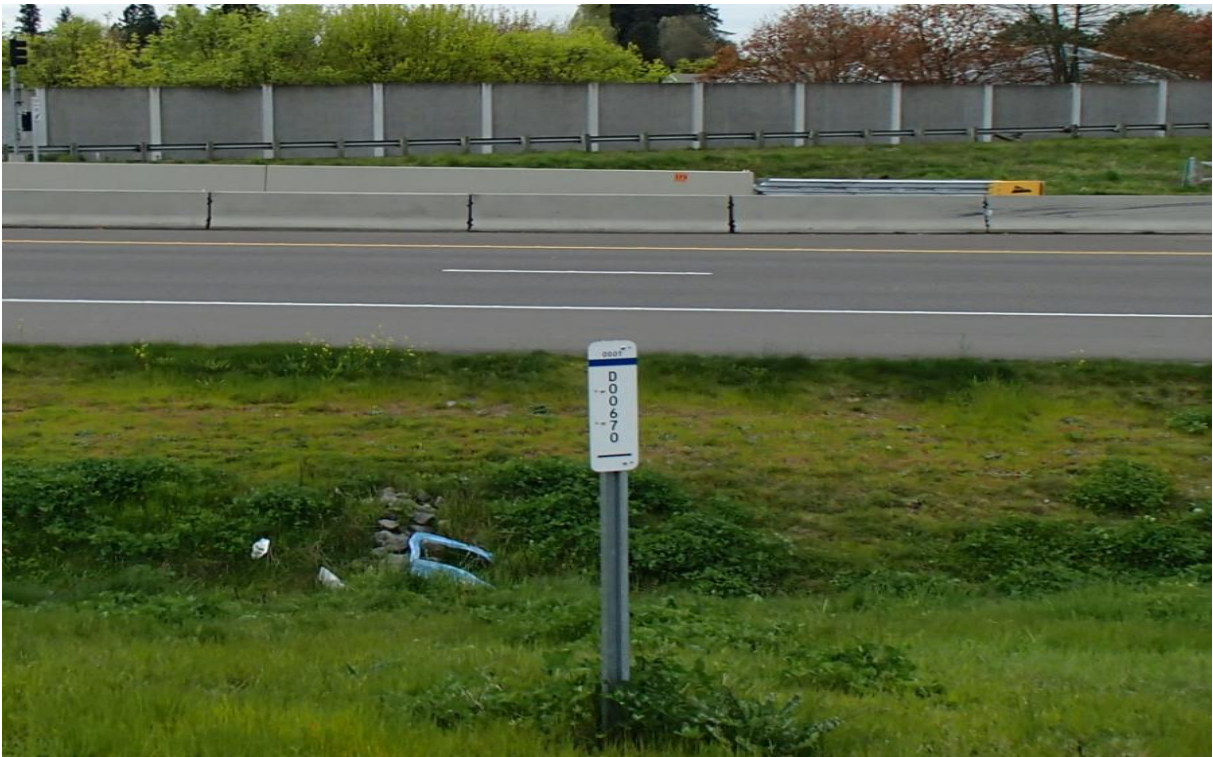

[April, 2014]

INDEX

1. IDENTIFICATION 1

2. FACILITY CONTACT INFORMATION 1

3. CONSTRUCTION..... 1

4. STORM DRAIN SYSTEM AND FACILITY OVERVIEW 2

5. FACILITY HAZ MAT SPILL FEATURE(S)..... 4

6. AUXILIARY OUTLET (HIGH FLOW BYPASS)..... 4

7. MAINTENANCE REQUIREMENTS..... 5

8. WASTE MATERIAL HANDLING..... 5

APPENDIX A: Operational Plan and Profile Drawing

APPENDIX B: ODOT Project Plan Sheets

1. Identification

Drainage Facility ID (DFI): **D00670**

Facility Type: Bio-Retention Pond

Construction Drawings: (V-File Number) 46V-022

Location: District: 2B

Highway No.: 68

Mile Post: (10.02 to 10.05) Hwy 68

Description: This facility is located south of the Sunrise Corridor, west of OR 213 (Cascade Highway North) and east of the off ramp from Interstate 205 to the Sunrise Corridor.

2. Facility Contact Information

Contact the Engineer of Record, Region Technical Center, or Geo-Environmental's Senior Hydraulics Engineer for:

- Operational clarification
- Maintenance clarification
- Repair or restoration assistance

Engineering Contacts:

Region Technical Center Hydro Unit Manager

Or

Geo-Environmental Senior Hydraulics Engineer (503) 986-3365.

3. Construction

Engineer of Record: Consultant Designer – [OBEC Consulting Engineers, Amy Jones, 971-634-2005]

Facility construction: [2014]

Contractor: Kerr Contractors, Inc.

4. Storm Drain System and Facility Overview

A bio-retention pond is a basin that is designed to capture the water quality design volume and filter out the pollutants by filtering the runoff through the water quality mix constructed in the pond bottom. The filtration process removes a variety of pollutants through physical, biological and chemical treatment mechanisms. The water in the facility exits through an under drain pipe below the water quality mix. The outlet control structure limits the rate of runoff leaving the pond by using an orifice. These facilities are designed to infiltrate the water quality design storm volume within 36 hours. The sizing of these facilities depends on the location and the amount of contributing impervious area.

This bio-retention pond is designed to store runoff during wet weather and is dry the remainder of the time. It is located south of the Sunrise Corridor, west of OR 213 (Cascade Highway North) and east of the off ramp from Interstate 205 to the Sunrise Corridor. Access to the facility is provided with a maintenance access road connecting to the ramp shoulder.

There are two 18-inch culverts that convey stormwater runoff from paved areas along 82nd Avenue, 82nd Drive, and the I-205 off ramp into the detention pond. The location of these are noted on the Operation Plan as points A, and B in Appendix A

Runoff exits the pond by way of a Type “D” inlet and 12-inch storm drain pipe that connects to a manhole containing the flow control assembly. See Photo 1 and Points C and D on the Operational Plan in Appendix A.

The storm drain outlet pipe from the flow control manhole connects to the downstream pipe system. These are shown in the Operational Plan in Appendix A. The receiving waterway for the outlet pipes is Dean Creek.

A. Maintenance equipment access:

The pond and outlet structures can be accessed from the ramp shoulder and from a maintenance access road connecting to the ramp shoulder. See the road layout on the Operational Plan in Appendix A.

B. Heavy equipment access into facility:

- Allowed (no limitations)
- Allowed (with limitations)
- Not allowed

C. Special Features:

- Amended Soils

- ☒ Porous Pavers
- ☐ Liners
- ☒ Underdrains

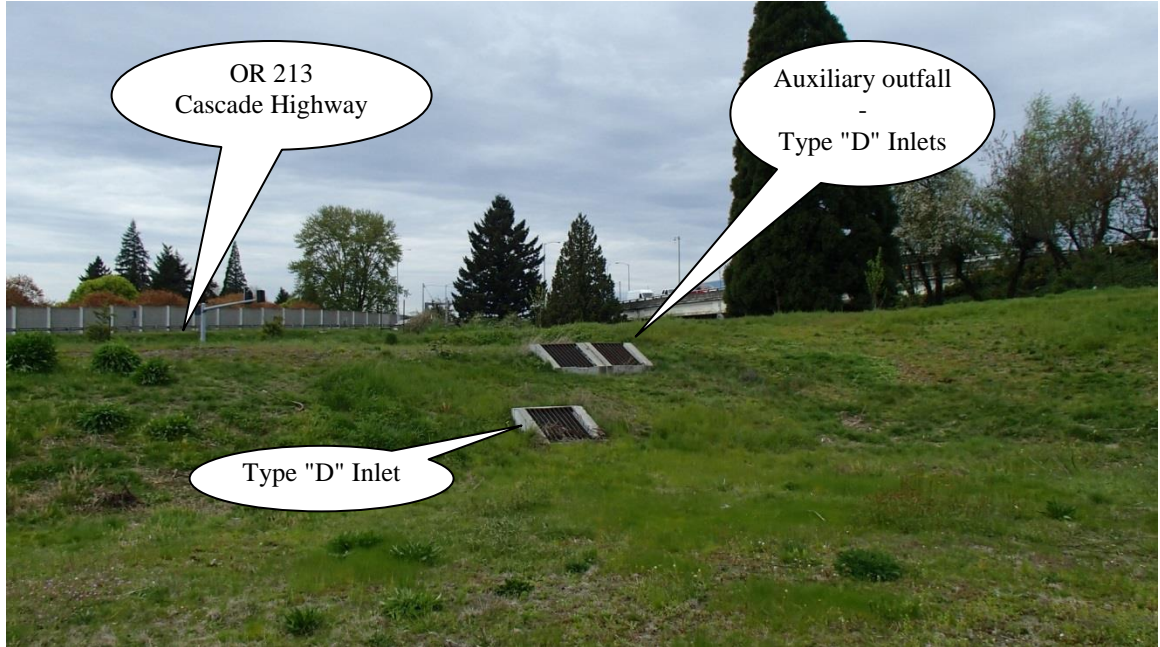

Photo 1: a view of bio-retention pond facility, looking West at Cascade highway.

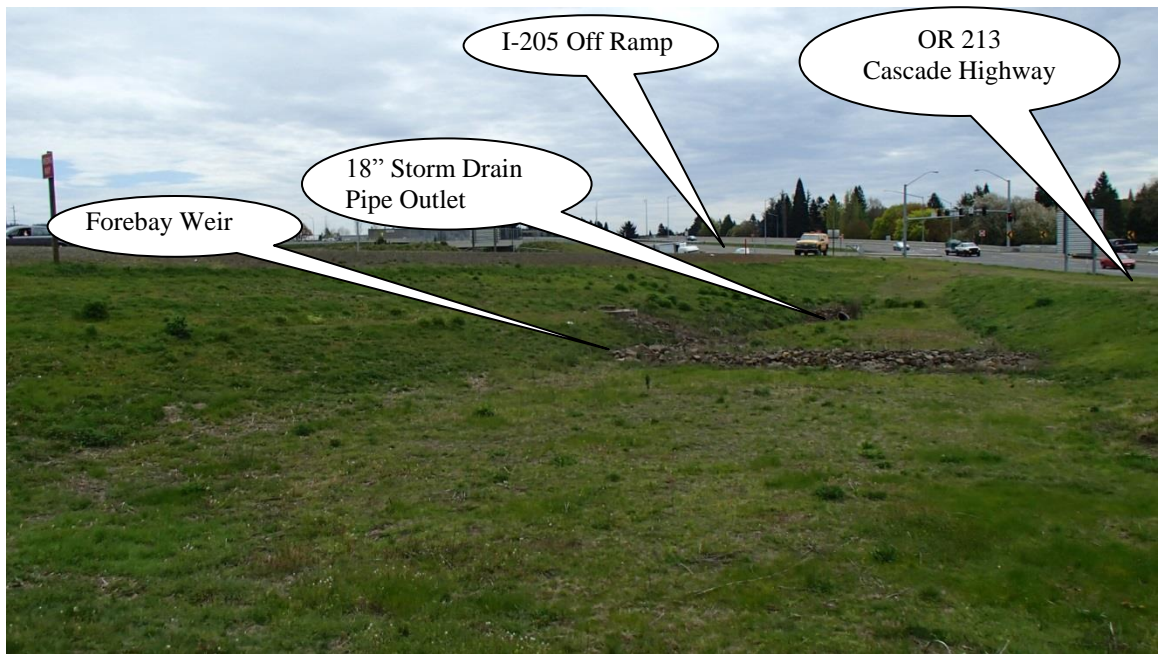

Photo 2: a view of bio-retention pond facility, looking South.

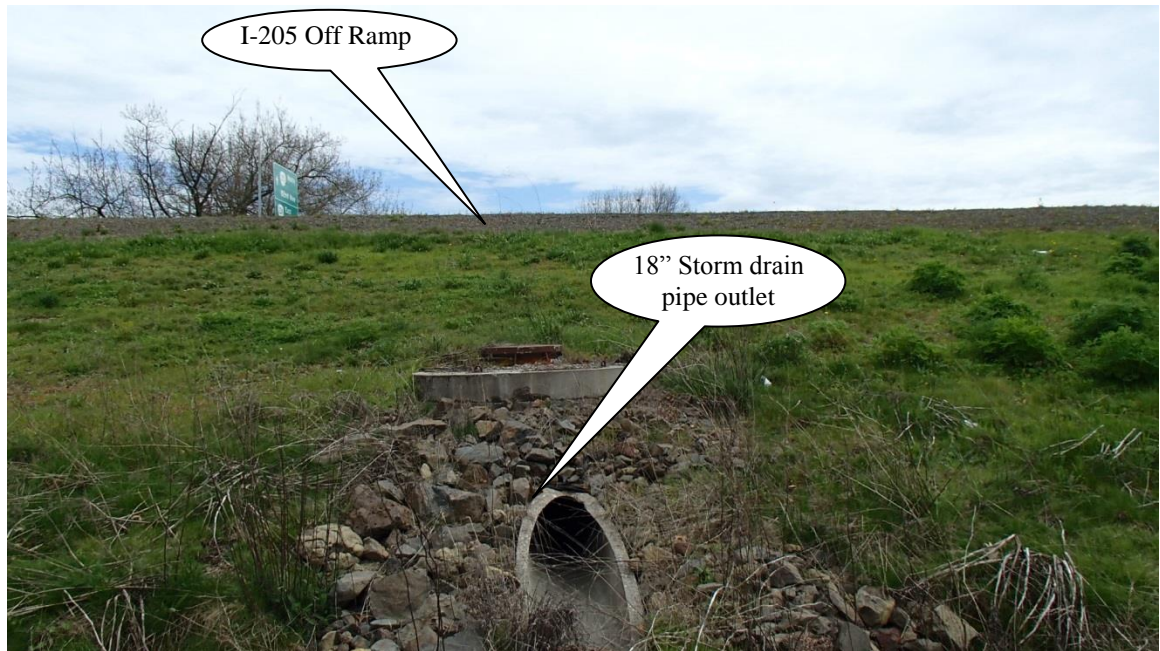

Photo 3: a view of 18" storm drain pipe outlet, looking East toward I-205 off ramp.

5. Facility Haz Mat Spill Feature(s)

The pond can be used to store a volume of liquid by blocking the 12-inch diameter outlet pipe with the Type "D" inlet located at the outfall structure on the south side of the pond. This is noted as point B in the Operational Plan. A barrier such as a metal plate over the metal grate on the inlet could be used to prevent liquid from draining from the pond.

6. Auxiliary Outlet (High Flow Bypass)

Auxiliary Outlets are provided if the primary outlet control structure cannot safely pass the projected high flows. Broad-crested spillway weirs and over flow risers are the two most common auxiliary outlets used in stormwater facility design. The auxiliary outlet feature is either a part of the facility or an additional storm drain feature/structure.

The auxiliary outlet feature for this facility is:

Designed into facility

High flows exit the pond through the auxiliary outlet structure consisting of two "D" inlets and a 12-inch outfall pipe. This connects to the flow control manhole noted as Point D on the Operation Plan. See Photo1 and Points E and F in the Operational Plan in Appendix A.

Other, as noted below

There is an underdrain pipe system designed to provide infiltration for the pond.

7. Maintenance Requirements

Routine maintenance table for non-proprietary stormwater treatment and storage/detention facilities have been incorporated into ODOT's Maintenance Guide. These tables summarize the maintenance requirements for ponds, swales, filter strips, bioslopes, and detention tanks and vaults. Special maintenance requirements in addition to the routine requirements are noted below when applicable.

The ODOT Maintenance Guide can be viewed at the following website:

<http://www.oregon.gov/ODOT/HWY/OOM/MGuide.shtml>

The following stormwater facility maintenance table (See ODOT Maintenance Guide) should be used to maintain the facility outlined in this Operation and Maintenance Manual:

- Table 1 (general maintenance)
- Table 2 (stormwater ponds)
- Table 3 (water quality biofiltration swales)
- Table 4 (water quality filter strips)
- Table 5 (water quality bioslopes)
- Table 6 (detention tank)
- Table 7 (detention vault)
- Appendix C (proprietary structure)
- Special Maintenance requirements

8. Waste Material Handling

Material removed from the facility is defined as waste by DEQ. Refer to the roadwaste section of the ODOT Maintenance Yard Environmental Management System (EMS) Policy and Procedures Manual for disposal options: <http://egov.oregon.gov/ODOT/HWY/OOM/EMS.shtml>

Contact any of the following for more detailed information about management of waste materials found on site:

ODOT Clean Water Unit	(503) 986-3008
ODOT Statewide Hazmat Coordinator	(503) 229-5129
ODOT Region Hazmat Coordinator	(503) 731-8290
ODEQ Northwest Region Office	(503) 229-5263

Appendix A

Content:

- **Operational Plan and Profile Drawing**

LEGEND:

- ◁ Photo Location / Direction
- ⊙ A 18" storm drain pipe outlet
- ⊙ B 18" storm drain pipe outlet
- ⊙ C Type "D" Inlet and 12" storm drain pipe outfall
- ⊙ D Flow control manhole
- ⊙ E Auxiliary outfall - 2 Type "D" Inlets and 24" storm drain pipe outfall
- ⊙ F Storm drain manhole
- ⊙ and ⊙ Manhole
- and □ Inlet
- Storm Pipe (Facility)
- Storm Pipe (Not connected to facility)
- Storm Pipe (Existing)
- Conveyance Direction
- Pavement / Facility Flow Path

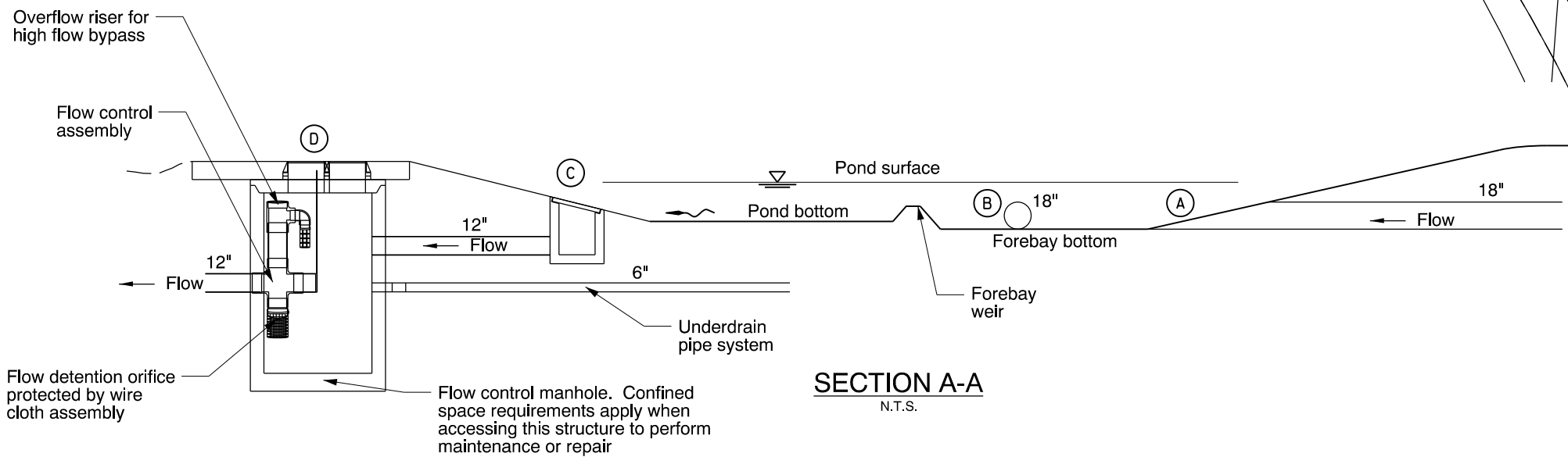
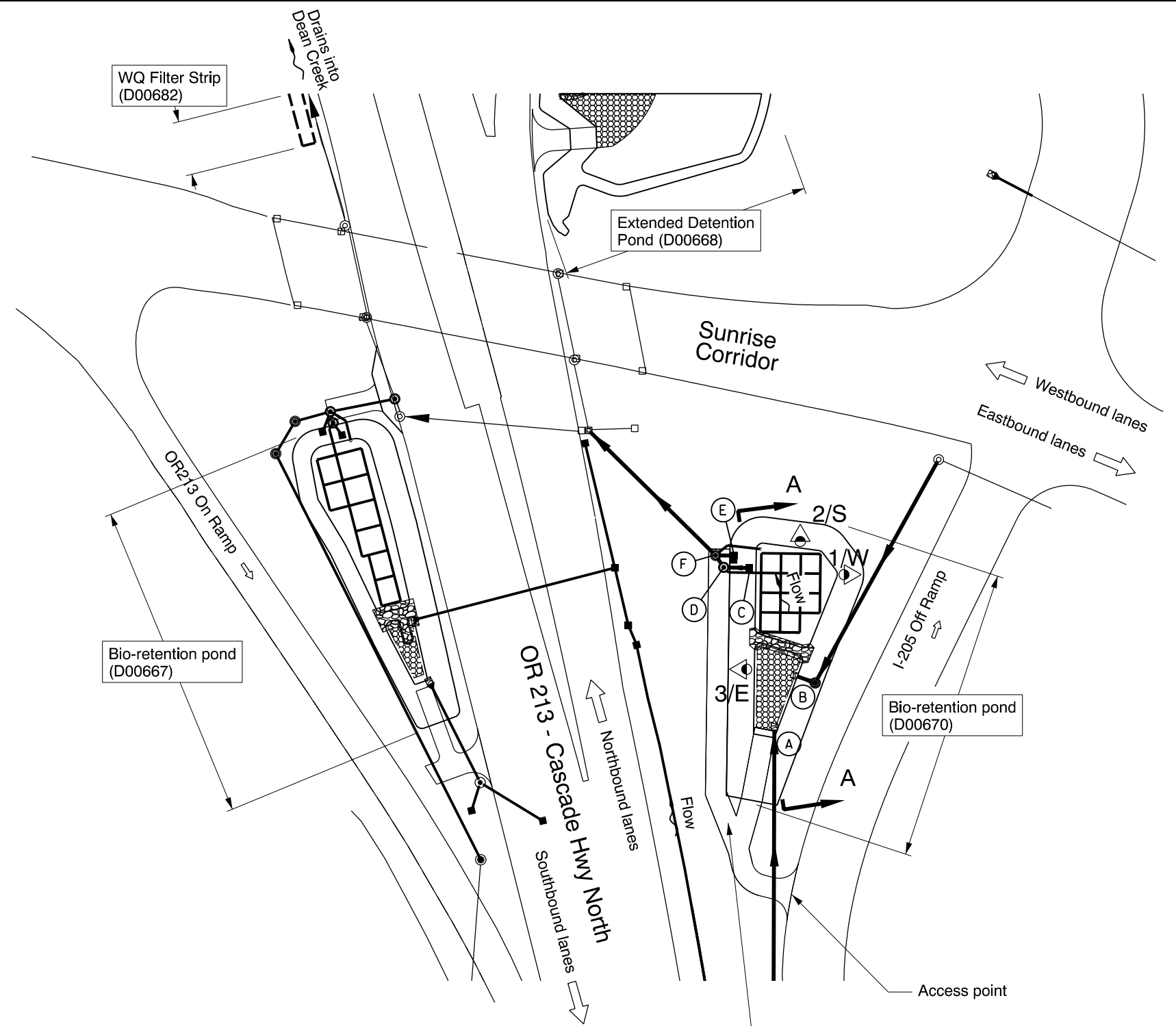

PLAN
N.T.S.

SECTION A-A
N.T.S.

OREGON DEPARTMENT OF TRANSPORTATION

Prepared By: Amy Jones
Drafted By: Amy Jones

DFI D00670
MAINTENANCE DISTRICT 2B HWY 68
BIO-RETENTION POND
CASCADE HWY NORTH MP 10.02 TO 10.05
CLACKAMAS COUNTY

Appendix B

Content:

- **ODOT Project Plan Sheets**
 - *Cover/Title Sheet*
 - *Water Quality/Detention Plan Sheets*
 - *Other Details*

STATE OF OREGON
 DEPARTMENT OF TRANSPORTATION
 PLANS FOR PROPOSED PROJECT
**GRADING, DRAINAGE, STRUCTURES, PAVING, SIGNING,
 ILLUMINATION, SIGNALS & ROADSIDE DEVELOPMENT**

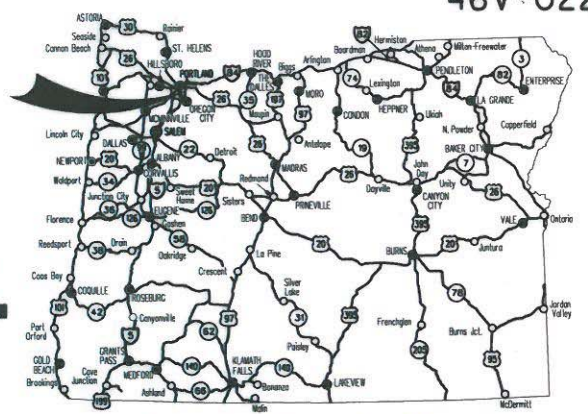

Overall Length Of Project - 3.90 Miles

INDEX OF SHEETS	
SHEET NO.	DESCRIPTION
1	Title Sheet
1A	Index Of Sheets Cont'd.

FFO - OR212/224: SUNRISE CORRIDOR (I-205 - SE 122ND AVE) SEC.

**CLACKAMAS HWY.
 CLACKAMAS COUNTY
 MARCH 2013**

**BEGIN WORK
 JTA-STP-S171(030)
 STA. "SR1" 505+78**

**BEGIN WORK
 JTA-STP-S171(030)
 STA. "G" 463+00**

**END WORK
 JTA-STP-S171(030)
 STA. "G" 492+00**

**END WORK
 JTA-STP-S171(030)
 STA. "OR" 352+20**

**END WORK
 JTA-STP-S171(030)
 STA. "T" 705+75**

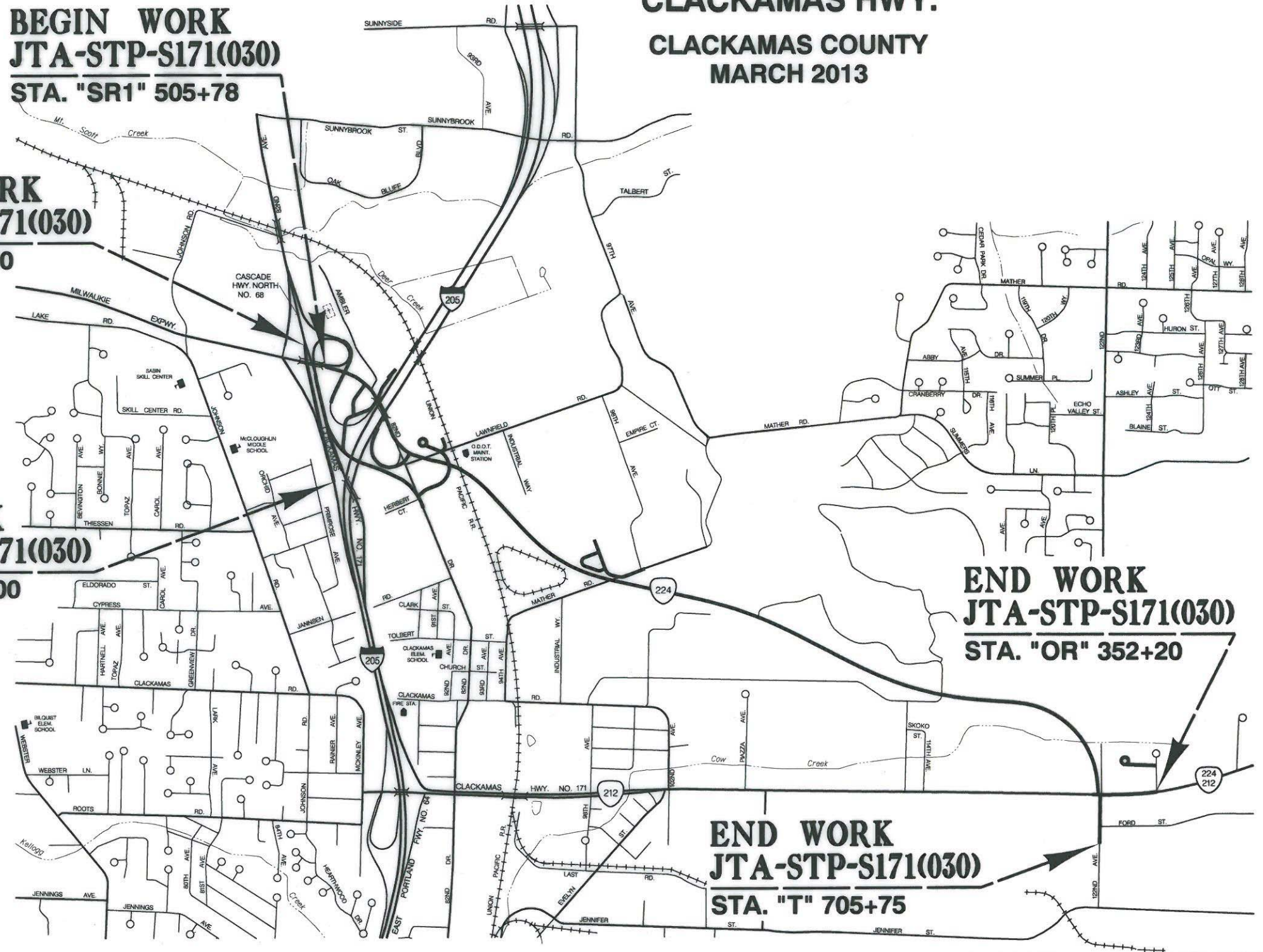

ATTENTION:
 Oregon Law Requires You To Follow Rules Adopted By The Oregon Utility Notification Center. Those Rules Are Set Forth In OAR 952-001-0010 Through OAR 952-001-0090. You May Obtain Copies Of The Rules By Calling The Center. (Note: The Telephone Number For The Oregon Utility Center is (503) 232-1987.)

**LET'S ALL
 WORK TOGETHER
 TO MAKE THIS
 JOB SAFE**

- OREGON TRANSPORTATION COMMISSION**
- Pat Egan CHAIR
 - David Lohman COMMISSIONER
 - Mary F. Olson COMMISSIONER
 - Mark Frohnmayer COMMISSIONER
 - Tammy Boney COMMISSIONER
 - Matthew L. Garrett DIRECTOR OF TRANSPORTATION

PLANS PREPARED FOR
 OREGON DEPARTMENT OF TRANSPORTATION

OBEC CONSULTING ENGINEERS
 CORPORATE OFFICE: 920 COUNTRY CLUB ROAD, SUITE 100B EUGENE, OREGON 97401-0089
 REGIONAL OFFICES: LAKE OSWEGO, SALEM, MEDFORD, OREGON; VANCOUVER, WASHINGTON

These plans were developed using ODOT design standards. Exceptions to these standards, if any, have been submitted and approved by the ODOT Chief Engineer or their delegated authority.

Approving Authority: *Lawrence H. Fox* 12/31/12
 Signature & date

LAWRENCE H. FOX - PROJECT MANAGER
 Print name and title

Concurrence by ODOT Chief Engineer

**FFO - OR212/224: SUNRISE CORRIDOR (I-205 - SE 122ND AVE) SEC.
 CLACKAMAS HWY.
 CLACKAMAS COUNTY**

FEDERAL HIGHWAY ADMINISTRATION	PROJECT NUMBER	SHEET NO.
OREGON DIVISION	JTA-STP-S171(030)	1

SEC. 4, 5, 9, 10, 11
 T. 2 S., R. 2 E., W.M.

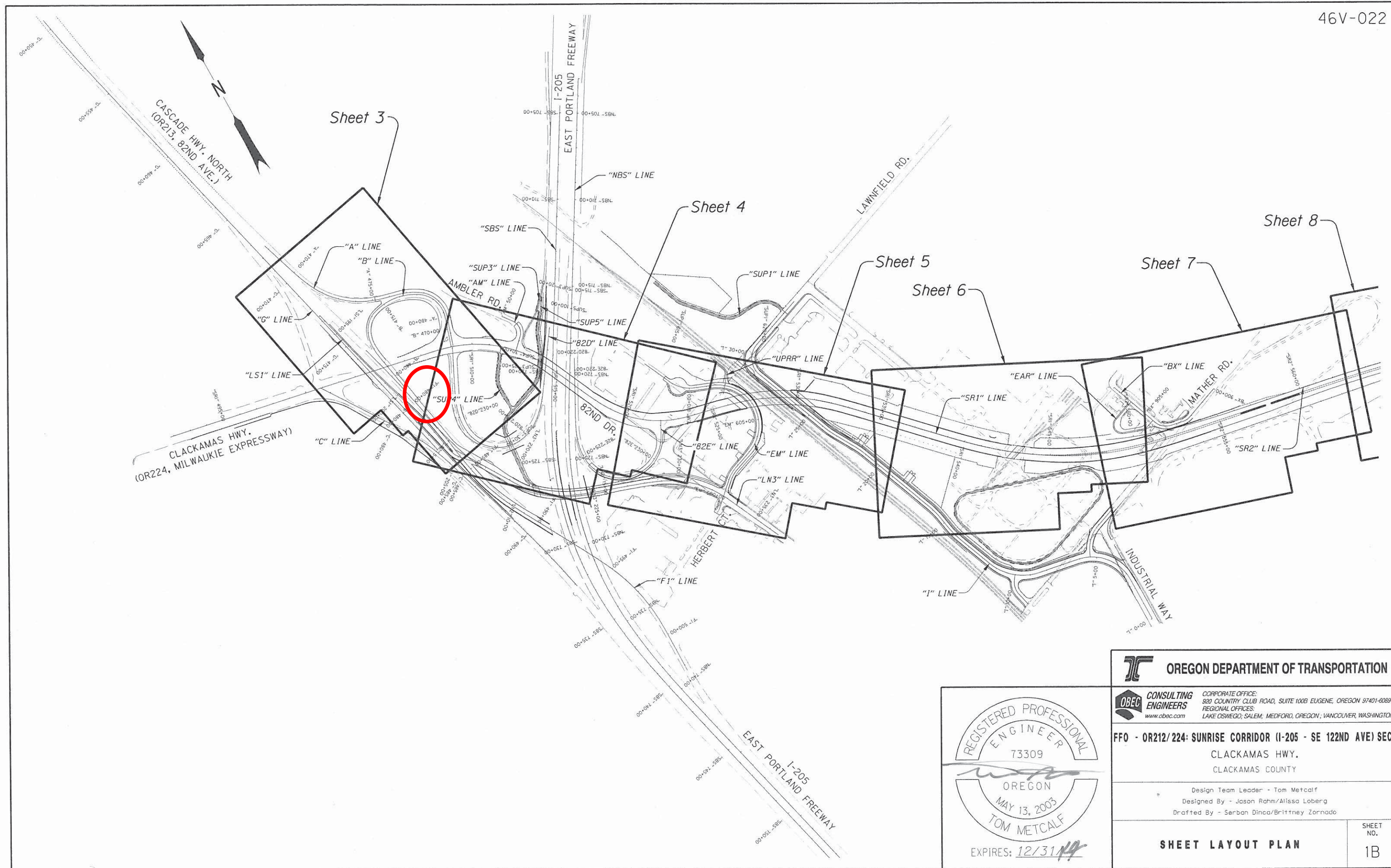

REGISTERED PROFESSIONAL
ENGINEER
73309
OREGON
MAY 13, 2003
TOM METCALF
EXPIRES: 12/31/14

OREGON DEPARTMENT OF TRANSPORTATION

OBEC CONSULTING ENGINEERS
CORPORATE OFFICE: 920 COUNTRY CLUB ROAD, SUITE 100B EUGENE, OREGON 97401-6089
REGIONAL OFFICES: LAKE OSWEGO, SALEM, MEDFORD, OREGON; VANCOUVER, WASHINGTON
www.obec.com

FFO - OR212/224: SUNRISE CORRIDOR (I-205 - SE 122ND AVE) SEC.
CLACKAMAS HWY.
CLACKAMAS COUNTY

Design Team Leader - Tom Metcalf
Designed By - Jason Rahm/Alissa Loberg
Drafted By - Serban Dinca/Brittney Zornado

SHEET LAYOUT PLAN
SHEET NO. 1B

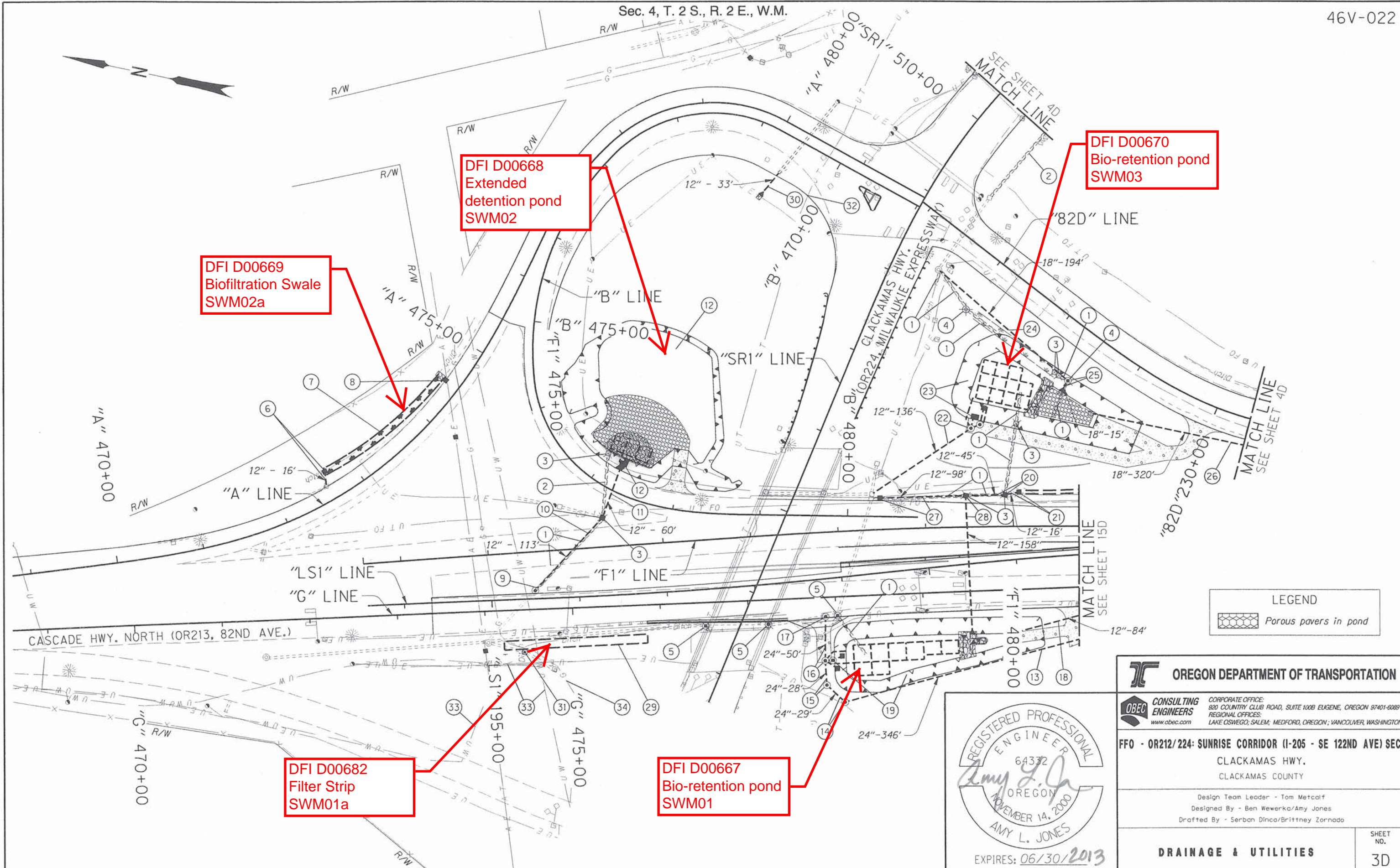

DFI D00669
Biofiltration Swale
SWM02a

DFI D00668
Extended
detention pond
SWM02

DFI D00670
Bio-retention pond
SWM03

DFI D00682
Filter Strip
SWM01a

DFI D00667
Bio-retention pond
SWM01

LEGEND

Porous pavers in pond

REGISTERED PROFESSIONAL
ENGINEER
64372
Amy L. Jones
OREGON
NOVEMBER 14, 2000
AMY L. JONES
EXPIRES: 06/30/2013

OREGON DEPARTMENT OF TRANSPORTATION

CONSULTING ENGINEERS
OBEC
www.obec.com

CORPORATE OFFICE:
920 COUNTRY CLUB ROAD, SUITE 100B EUGENE, OREGON 97401-6089
REGIONAL OFFICES:
LAKE OSWEGO, SALEM, MEDFORD, OREGON; VANCOUVER, WASHINGTON

FFO - OR212/224: SUNRISE CORRIDOR (I-205 - SE 122ND AVE) SEC.
CLACKAMAS HWY.
CLACKAMAS COUNTY

Design Team Leader - Tom Metcalf
Designed By - Ben Wewerka/Amy Jones
Drafted By - Serban Dinca/Brittney Zornada

DRAINAGE & UTILITIES

SHEET NO.
3D

- ① Remove pipe - 590'
- ② Abandon pipe
- ③ Remove inlet - 6
- ④ Remove manhole - 2
- ⑤ Minor adjust manhole - 3
(See drg. no. RD360)
- ⑥ Sta. "A" 472+66.6, Lt.
Const. type "D" inlet
Inst. 12" storm sew. pipe - 16'
5' depth
Connect to extg. inlet
(See drg. nos. RD300, RD326, RD370, RD380 & RD386)
- ⑦ Const. water quality swale, D00669 (SWM02a)
Inst. facility field markers, type S1 - 2
Inst. facility field marker, type S2
(For details, see sht. GJ-5B)
(See drg. no. RD399)
- ⑧ Sta. "A" 474+49.5, Lt.
Const. modified curb opening
(For details, see sheet 2B-14)
- ⑨ Sta. "F1" 474+50.64, 44.18' Lt.
Const. storm manhole over extg. storm sew. pipe
(See drg. nos. RD335, RD336, RD344 & RD356)
- ⑩ Sta. "F1" 475+32.86, 33.40' Lt.
Const. type "G-2M" inlet
Inst. 12" storm sew. pipe - 113'
10' depth
Tunneling, boring & jacking
(See drg. nos. RD308 & RD364)
- ⑪ Sta. "B" 477+24.04, 27.08' Lt.
Inst. 12" storm sew. pipe - 60'
5' depth
(See drg. no. RD302)
- ⑫ Const. storage pond, D00668 (SWM02)
Inst. facility field markers, type S1 - 2
Inst. facility field marker, type S2
Aggregate base - 65 tons
(For details, see sht. GJ-5)
- ⑬ Sta. "G" 481+44.11, 43.83' Rt. to
Sta. "G" 478+06.33, 119.98' Rt.
Inst. 24" storm sew. pipe - 346'
10' depth
- ⑭ Sta. "G" 478+06.33, 119.98' Rt.
Const. storm manhole 60" dia.
Inst. 24" storm sew. pipe - 29'
10' depth
(See drg. no. RD346)
- ⑮ Sta. "G" 477+86.16, 99.75' Rt.
Const. storm manhole 60" dia.
Inst. 24" storm sew. pipe - 28'
10' depth
- ⑯ Sta. "G" 477+85.48, 71.88' Rt.
Const. storm manhole 72" dia.
Inst. 24" storm sew. pipe - 50'
10' depth
- ⑰ Sta. "G" 477+88.02, 22' Rt.
Const. storm manhole 72" dia.
over extg. storm sew. pipe

- ⑱ Sta. "G" 480+87.09, 29.88' Rt. to Sta. "G" 480+04.97, 48.42' Rt.
Inst. 12" storm sew. pipe - 84'
5' depth
Const. sloped end
Const. riprap basin
(For details, see sht. GJ-22)
(For profile, see sht. 15F)
(See drg. nos. RD318 & RD316)
- ⑲ Const. bio-retention pond, D00667 (SWM01)
Inst. facility field markers, type S1 - 2
Inst. facility field marker, type S2
Conc. pipe anchor
Aggregate base - 150 tons
6" gate valve
(For details, see shts. GJ-4, GJ-4A, GJ-4B & GJ-21)
- ⑳ Sta. "F1" 479+91.16, 36.14' Lt.
Const. type "G-2" inlet
Inst. 12" storm sew. pipe - 45'
5' depth
- ㉑ Sta. "F1" 480+06.94, 39.09' Lt.
Const. type "D" inlet
Inst. 12" storm sew. pipe - 16'
5' depth
- ㉒ Sta. "F1" 479+54.26, 112.66' Lt.
Const. storm manhole 60" dia.
Inst. 12" storm sew. pipe - 136'
5' depth
- ㉓ Const. bio-retention pond, D00670 (SWM03)
Inst. facility field markers, type S1 - 2
Inst. facility field marker, type S2
Conc. pipe anchor
Aggregate base - 425 tons
6" gate valve
(For details, see shts. GJ-6 & GJ-6A)
- ㉔ Sta. "82D" 231+56.63, 60.5' Lt. to Sta. "82D" 233+49.63, 50.3' Lt.
Inst. 18" storm sew. pipe - 194'
10' depth
Connect to extg. manhole
(For profile, see sht. 4F-2)
- ㉕ Sta. "82D" 231+56.63, 60.5'
Const. storm manhole 60" dia.
Inst. 18" storm sew. pipe - 15'
5' depth
Const. sloped end
Const. paved end slope, Rt.
Const. riprap basin
(For detail, see sht. GJ-22)
(For profile, see sht. 4F-2)
(See drg. no. RD320)
- ㉖ Sta. "82D" 228+38.20, 57.3' Lt. to Sta. "82D" 231+14.08, 74.41' Lt.
Inst. 18" storm sew. pipe - 320'
10' depth
Const. sloped end
Const. riprap basin
(For detail, see sht. GJ-22)
(For profile, see sht. 4F-2)
- ㉗ Sta. "F1" 478+49.52, 35.94', Lt.
Const. type "G-2" inlet
Inst. 12" storm sew. pipe - 98'
5' depth

- ㉘ Sta. "F1" 479+46.43, 35.8' Lt.
Const. type "G-2" inlet
Inst. 12" storm sew. pipe - 158'
10' depth
Const. sloped end
Const. paved end slope, Rt
Tunneling, boring & jacking
- ㉙ Const. water quality filter strip, D00682 (SWM01a)
Inst. facility field marker, type S1 - 2
Inst. facility field marker, type S2
(For details, see sht. GJ-4C)
- ㉚ Sta. "B" 470+56.04, 43.95' Lt.
Extend - 33', Lt. 5' depth
Const. sloped end
Const. paved end slope, Lt.
Const. riprap basin
(For details, see sht. GJ-22)
- ㉛ Sta. "G" 474+43.5, 48.25' Rt.
Adjust inlet
(See drg. no. RD376)
- ㉜ Preserve and protect telephone line
- ㉝ Preserve and protect water line
- ㉞ Preserve and protect gas line

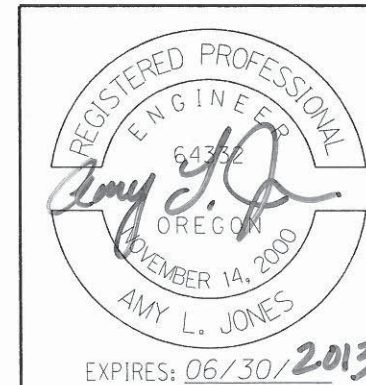
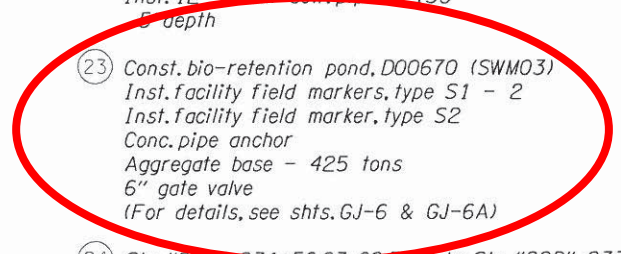

OREGON DEPARTMENT OF TRANSPORTATION	
	CONSULTING ENGINEERS <small>www.obec.com</small> CORPORATE OFFICE: 920 COUNTRY CLUB ROAD, SUITE 100B EUGENE, OREGON 97401-6088 REGIONAL OFFICES: LAKE OSWEGO; SALEM; MEDFORD, OREGON; VANCOUVER, WASHINGTON
FFO - OR212/224: SUNRISE CORRIDOR (I-205 - SE 122ND AVE) SEC.	
CLACKAMAS HWY. CLACKAMAS COUNTY	
Design Team Leader - Tom Metcalf Designed By - Ben Wewarka/Amy Jones Drafted By - Serban Dinca/Brittney Zornado	
DRAINAGE & UTILITIES NOTES	SHEET NO. 3E

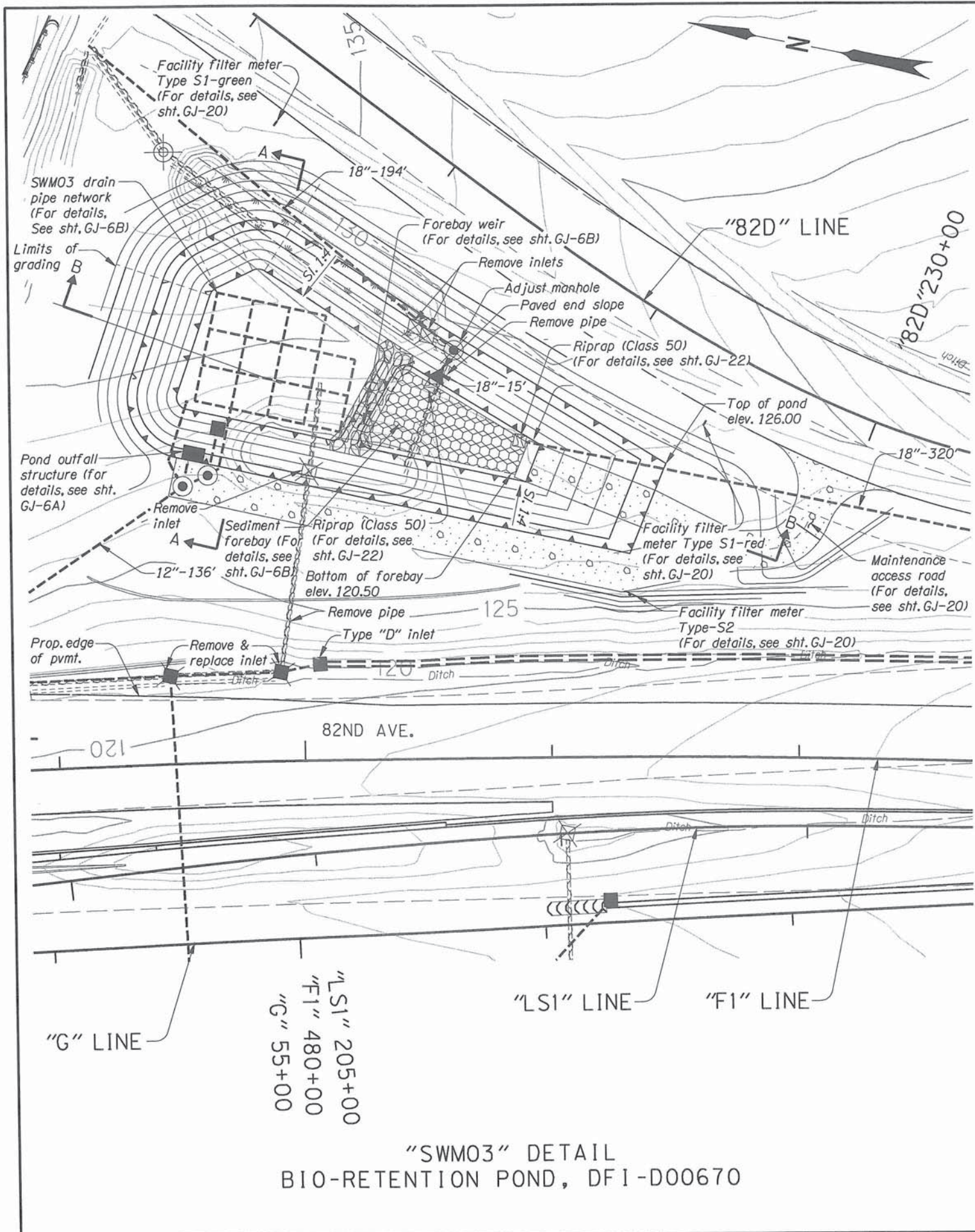

"SWM03" DETAIL
BIO-RETENTION POND, DFI-D00670

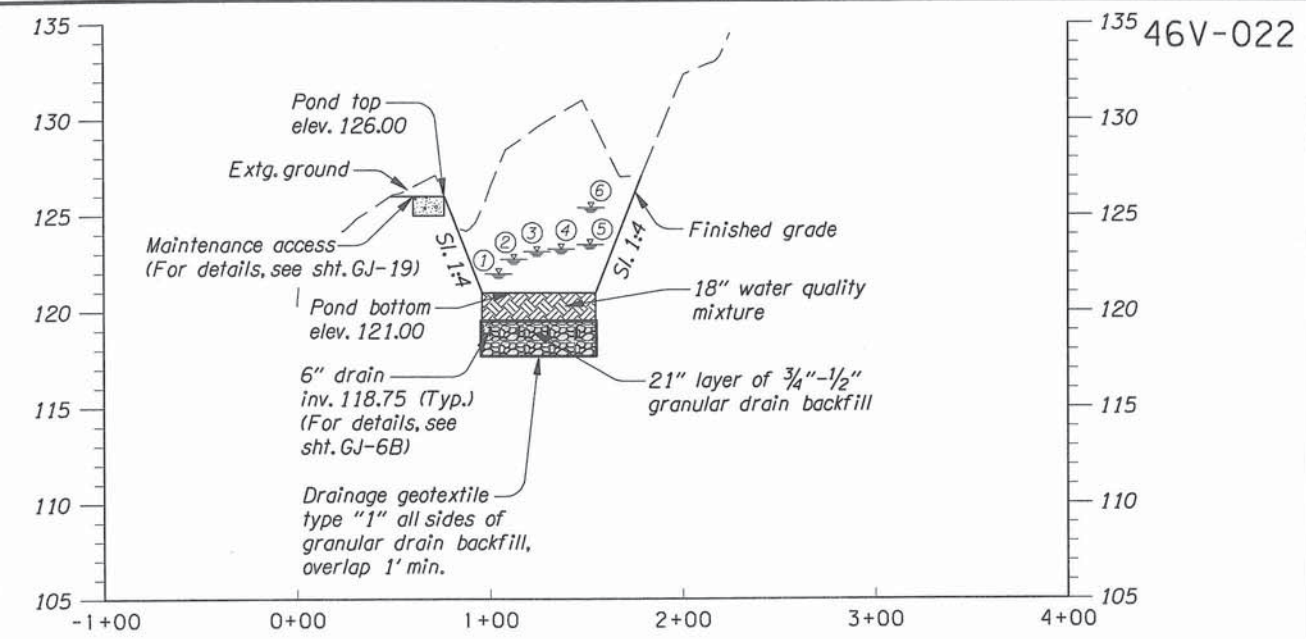

SECTION A-A

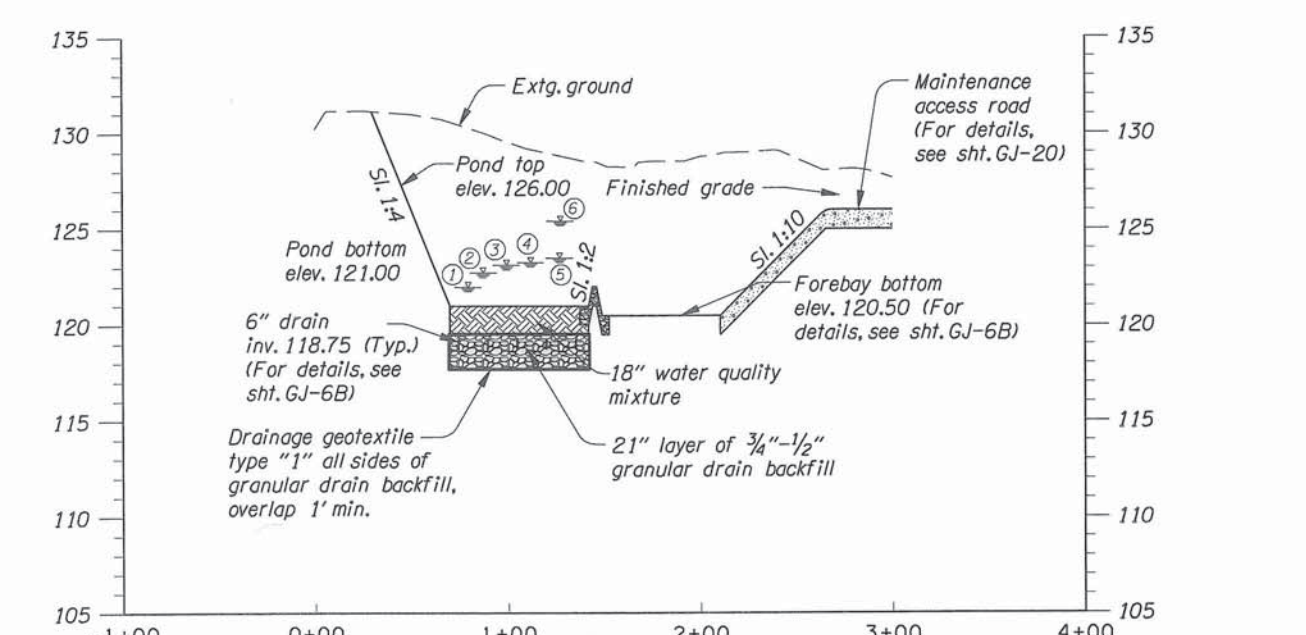

SECTION B-B

- ① Water quality WSE - 121.54
- ② 2 year WSE - 122.09
- ③ 10 year WSE - 122.83
- ④ 25 year WSE - 123.02
- ⑤ 50 year WSE - 123.26
- ⑥ 100 year WSE - 125.41
(Via emergency spillway only)

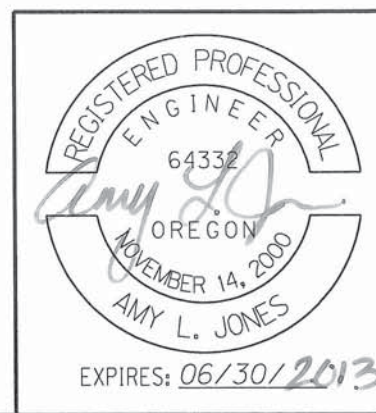

OREGON DEPARTMENT OF TRANSPORTATION

OBEC CONSULTING ENGINEERS
CORPORATE OFFICE: 920 COUNTRY CLUB ROAD, SUITE 100B EUGENE, OREGON 97401-0089
REGIONAL OFFICES: LAKE OSWEGO, SALEM, MEDFORD, OREGON; VANCOUVER, WASHINGTON

FFO - OR212/224: SUNRISE CORRIDOR (I-205 - SE 122ND AVE) SEC. CLACKAMAS HWY. CLACKAMAS COUNTY

Design Team Leader - Tom Metcalf
Designed By - Ben Wewerka/Amy Jones
Drafted By - Serban Dinco/Brittney Zornada

STORMWATER DETAILS

SHEET NO. **GJ-6**

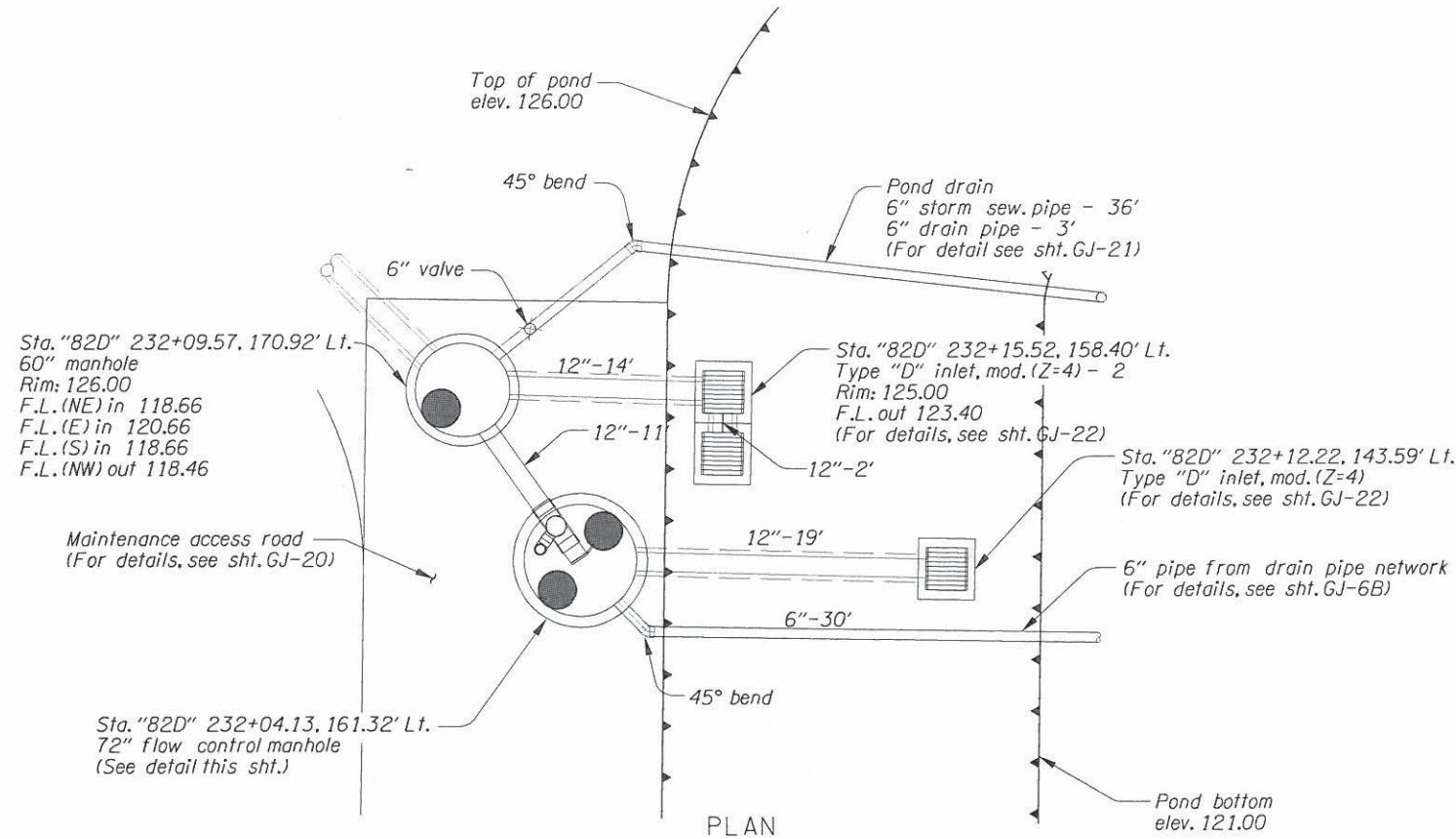

"SWM03" DETAIL
DF I-DO0670

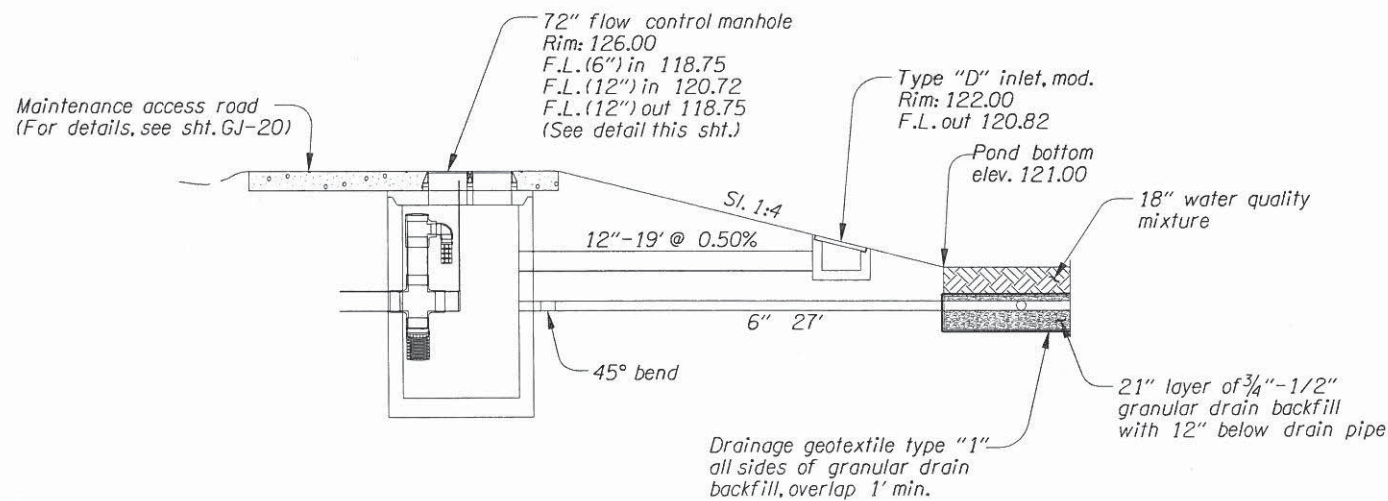

SECTION
OUTFALL STRUCTURE DETAIL

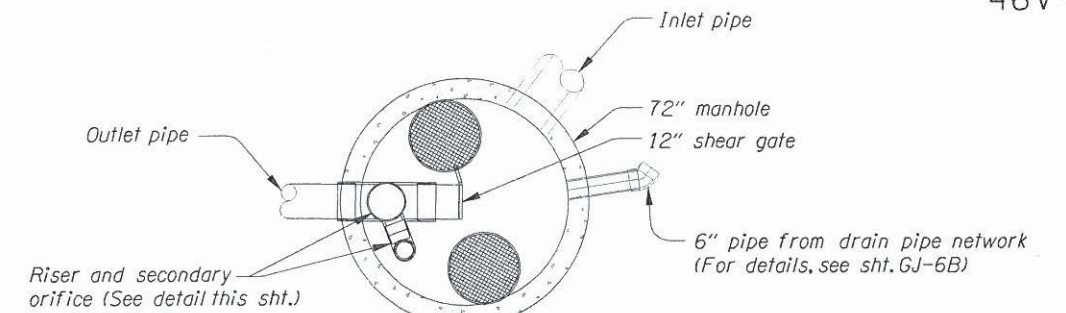

PLAN

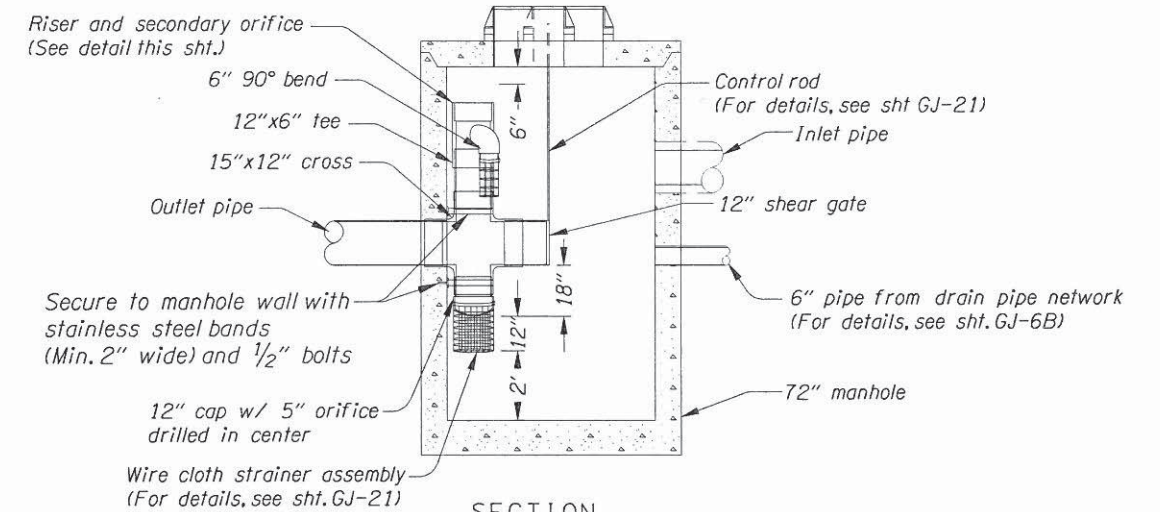

SECTION

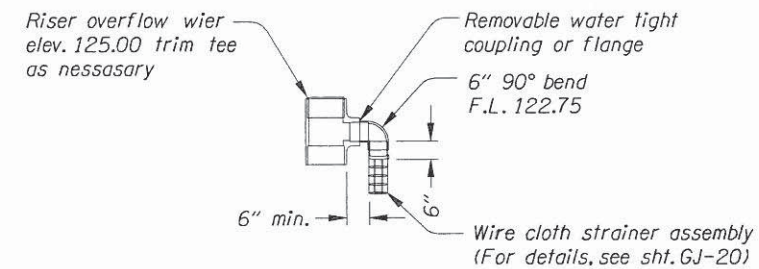

SECONDARY ORIFICE DETAIL

FLOW CONTROL MANHOLE

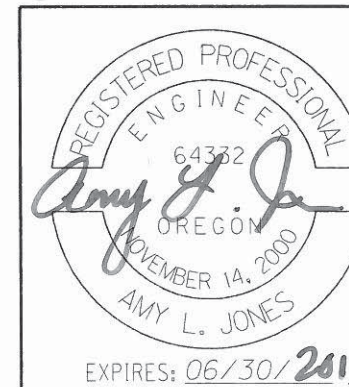

<p>OREGON DEPARTMENT OF TRANSPORTATION</p>	
<p>OBEC CONSULTING ENGINEERS www.obec.com</p>	<p>CORPORATE OFFICE: 920 COUNTRY CLUB ROAD, SUITE 100B EUGENE, OREGON 97401-6089 REGIONAL OFFICES: LAKE OSWEGO, SALEM, MEDFORD, OREGON; VANCOUVER, WASHINGTON</p>
<p>FFO - OR212/224: SUNRISE CORRIDOR (I-205 - SE 122ND AVE) SEC. CLACKAMAS HWY. CLACKAMAS COUNTY</p>	
<p>Design Team Leader - Tom Metcalf Designed By - Ben Wewerka/Amy Jones Drafted By - Serban Dinca/Brittney Zornado</p>	
<p>STORMWATER DETAILS</p>	
<p>SHEET NO. GJ-6A</p>	

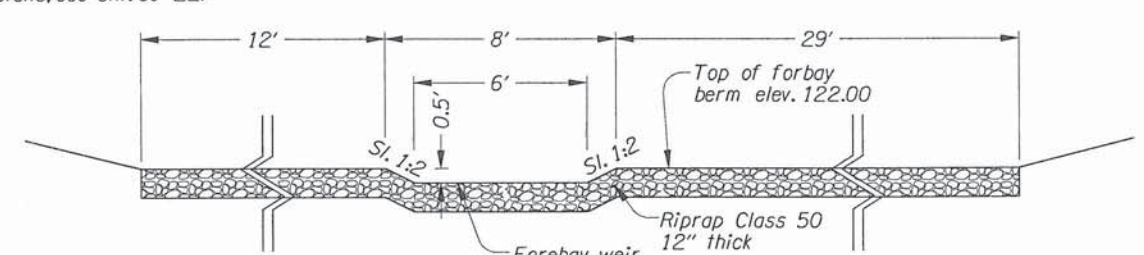
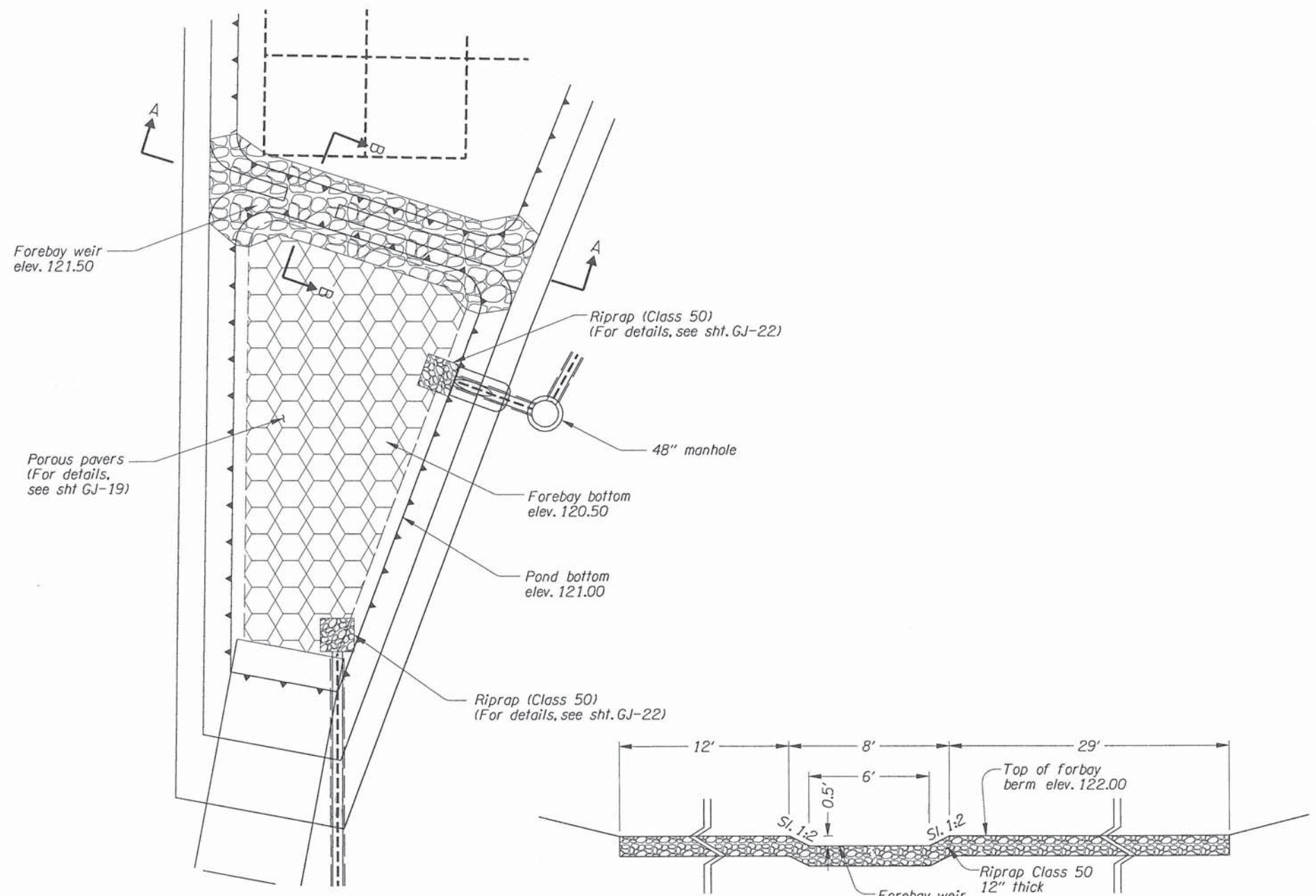

SECTION A-A

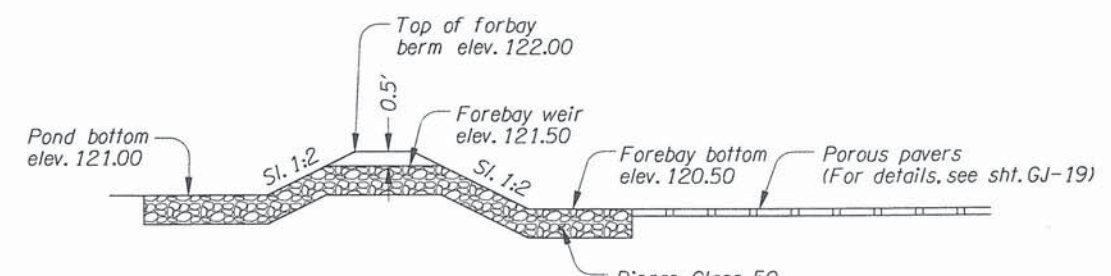

SECTION B-B

"SWM03" FOREBAY DETAIL
DF I -D00670

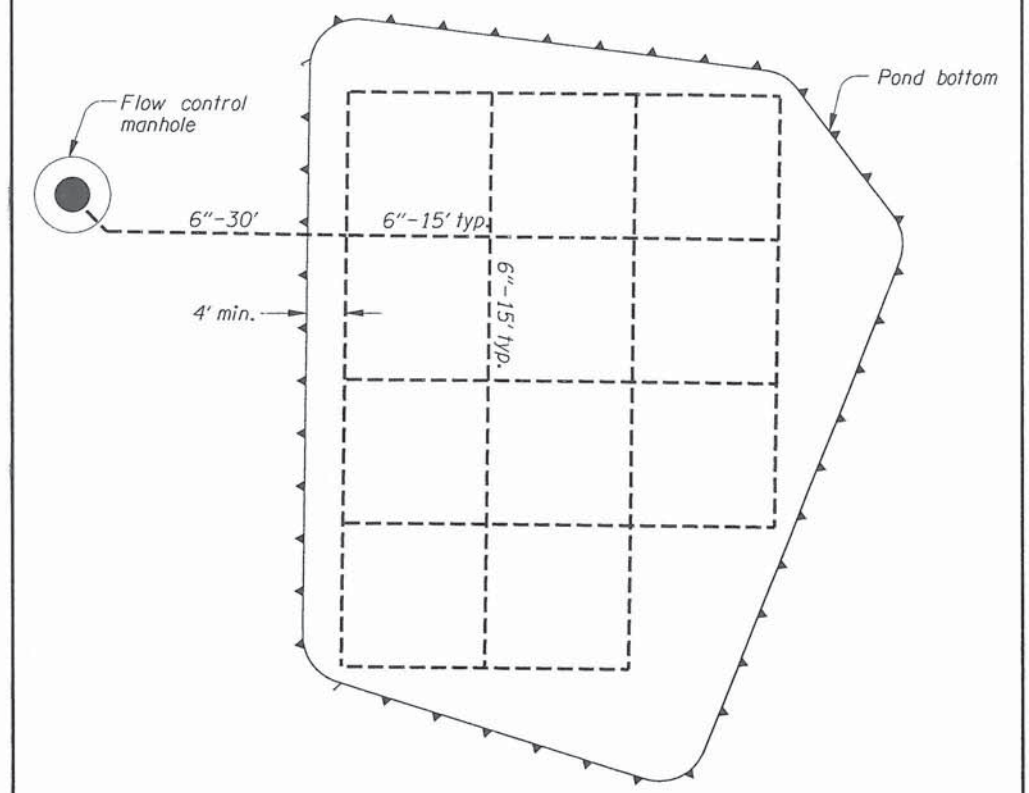

"SWM03" DRAIN PIPE DETAIL
DF I -D00670



CONSULTING ENGINEERS www.obec.com <small>CORPORATE OFFICE: 920 COUNTRY CLUB ROAD, SUITE 100B EUGENE, OREGON 97401-6089 REGIONAL OFFICES: LAKE OSWEGO, SALEM, MEDFORD, OREGON; VANCOUVER, WASHINGTON</small>	
FFO - OR212/224: SUNRISE CORRIDOR (I-205 - SE 122ND AVE) SEC. CLACKAMAS HWY. CLACKAMAS COUNTY	
Design Team Leader - Tom Metcalf Designed By - Ben Wewerka/Amy Jones Drafted By - Serban Dinca/Brittney Zornado	
STORMWATER DETAILS	SHEET NO. GJ-6B