

# OPERATION & MAINTENANCE MANUAL

## Water Quality Bioslope

Manual prepared: February 2019

DFI No. D00635



Figure 1: DFI No. D00635, looking southeast

## 1. Identification

Drainage Facility ID (DFI): D00635  
Facility Type: Water Quality Bioslope/Media Filter Drain (MFD)  
Construction Drawings: (V-File Numbers) 43V-086  
Location: District: 2B  
Highway No.: 047  
Mile Post: 66.08 – 66.35, [Right side]

## 2. Manual Purpose

The purpose of this manual is to outline inspection needs and summarize maintenance actions.

## 3. Facility Location

The location map below details the facility location. The highway, mile posts, side streets, access location, and stormwater flow directions are noted on the map. **NOTE: Mile posts are based off of the V-File, and may vary from TransGIS mile posts.**

Facility location type: **Roadway shoulder**

Flow direction: East



Figure 2: Facility Location Map

#### 4. Facility Summary

The width is measured perpendicular to the edge of pavement and is equivalent to the flow length. The length is measured parallel to the edge of pavement and is equivalent to the length of the contributing impervious area.

The length and width of the applicable facility components are:

<b>Component</b>	<b>Length (feet)</b>	<b>Width (feet)</b>
<b>Bioslope</b>	<b>1,384</b>	<b>8</b>

The slope of the facility is presented by a vertical distance (rise) followed by the horizontal distance (run).

<b>Side Slope</b>	<b>Rise (feet)</b>	<b>Run (feet)</b>
<b>Bioslope</b>	<b>1</b>	<b>6</b>

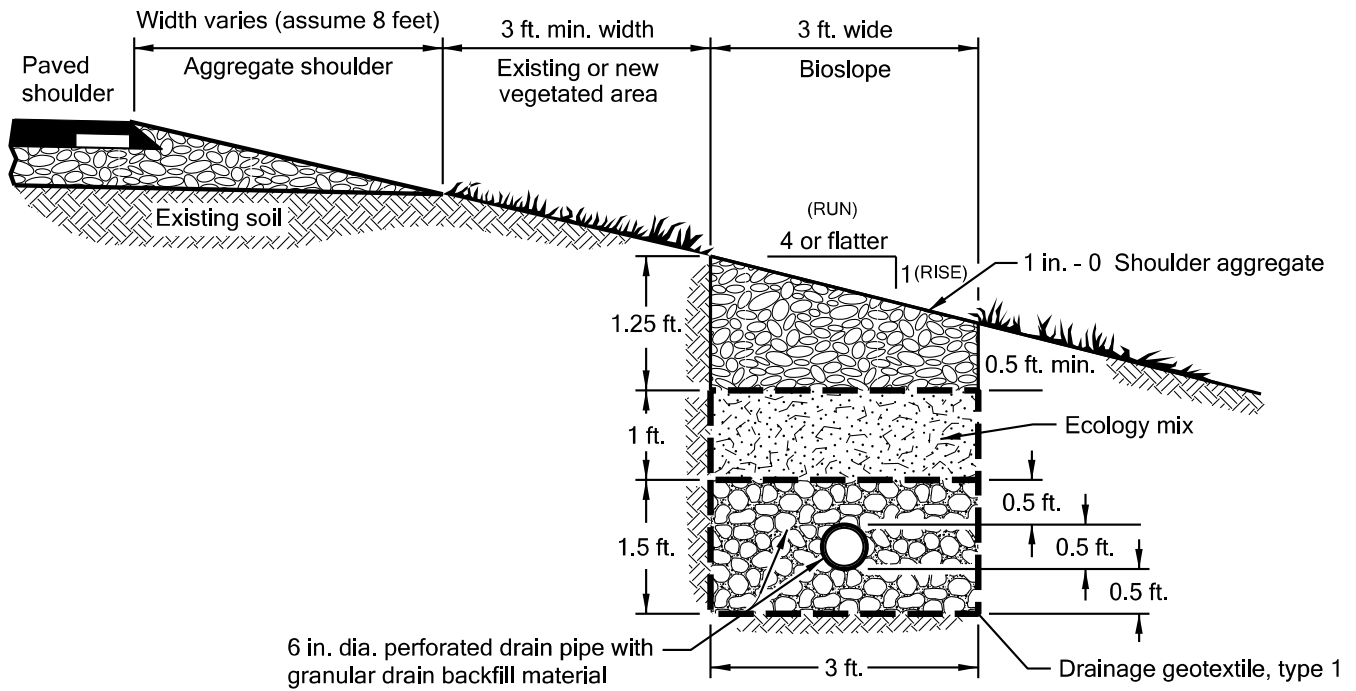

**Figure 3: BioSlope Section (Typical)**

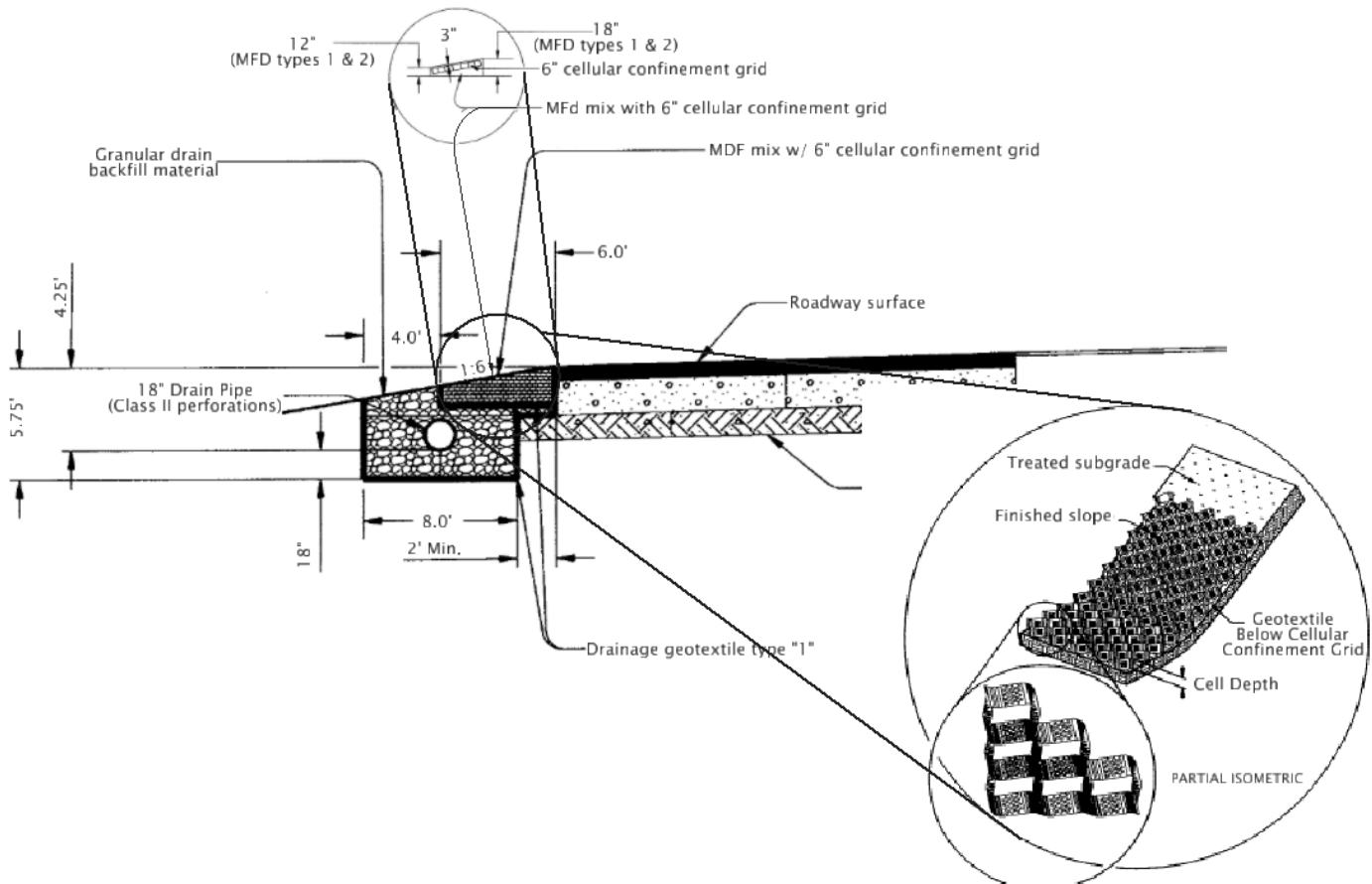

**Figure 4: Type 1 bioslope with slope configuration (No vegetated area/zone)**

**Site Specific Information:** This bioslope has one continuous type running from mile point 66.08 to 66.35 (See Appendix B, sheet GJ). The facility can be accessed via the highway shoulder. The water flows through the water quality facility to the west. It flows through a manhole before leaving the facility into a storm drain system. The water drains into Willow Creek.

**The facility is a modified version of the typical bioslope (Figure 3).** The main difference is the exclusion of a vegetation area between the edge of pavement and the bioslope section. This was developed as a result of right of way limitations, and in some locations, the prohibitive costs of moving adjacent high voltage line and frontage road.



## 5. Facility Access

Maintenance access to the facility:

<input type="checkbox"/> Roadside pad	<input checked="" type="checkbox"/> Roadside shoulder
<input type="checkbox"/> Access road with Gate	<input type="checkbox"/> Access road without Gate



Figure 5: Maintenance access

## 6. Operational Components / Maintenance Items

### Classification and Standard Operational (Op) Plan:

This facility is classified as a:

<p><input type="checkbox"/> <b>Filter Strip (Op Plan A)</b></p> <p>A filter strip consists of a vegetated or media slope located parallel to the edge of pavement. It maintains sheet flow of stormwater runoff over the width of the strip.</p>	<p><input checked="" type="checkbox"/> <b>Bioslope (Op Plan B)</b></p> <p>A bioslope consists of a filter strip and treatment zone. It is a flow-through stormwater treatment facility located along roadside embankments.</p>
<p><b>A standard operational plan illustrates the general facility footprint configuration and explains the purpose of each facility component. Operational plans (A, B) are provided in the Standard Operation Manual.</b></p>	

See Appendix A for the site specific operational plan.

### Operational Components

Filter strips and bioslopes have many components that assist with treatment, conveyance, and infiltration of stormwater runoff. The components in use can vary depending on the facility design. The facility components table (Table 1) has been provided to highlight the applicable components for this facility. The component is in use when the box contains an “x” (e.g.  ).

The Standard Operation Manual for Water Quality Filter Strips and Bioslopes (implemented February 2019) outlines facility operation, typical footprint configuration, and component definitions and details. A link to the manual is attached to the feature marker in TransGIS.

<https://gis.odot.state.or.us/TransGIS/>

## Maintenance Items

Operational components marked in Table 1 should be inspected and maintained according to Section 7. Each facility component is defined and detailed in the Standard Operation Manual using the associated ID number indicated below.

<b>Table 1: Bioslope/Filter Strip Components</b>		<b>ID #</b>
<b>Facility Inlet</b>		
Pavement Sheet Flow	<input checked="" type="checkbox"/>	<b>B1</b>
Flow Spreader	<input type="checkbox"/>	<b>B2</b>
<b>Ground Cover</b>		
Vegetated Slope	<input type="checkbox"/>	<b>B3</b>
Aggregate Media Slope	<input type="checkbox"/>	<b>B4</b>
<b>Underground Components</b>		
Water Quality Mix	<input type="checkbox"/>	<b>B5</b>
Ecology Mix	<input checked="" type="checkbox"/>	<b>B6</b>
Granular Drain Backfill Material	<input checked="" type="checkbox"/>	<b>B7</b>
Geotextile Fabric	<input checked="" type="checkbox"/>	<b>B8</b>
Cellular Confinement Grid	<input checked="" type="checkbox"/>	<b>B9</b>
<b>Structures</b>		
Curb/Berm	<input type="checkbox"/>	<b>B10</b>
Check Dam	<input type="checkbox"/>	<b>B11</b>
Cleanout	<input type="checkbox"/>	<b>B12</b>
<b>Facility Outlet</b>		
Perforated Drain Pipe	<input checked="" type="checkbox"/>	<b>B13</b>
Open Slope Outlet	<input type="checkbox"/>	<b>B14</b>
Open Channel Outlet	<input type="checkbox"/>	<b>B15</b>
Storm Drain Outlet Pipe	<input checked="" type="checkbox"/>	<b>B16</b>
<b>Outfall Type</b>		
Waterbody (Creek/Lake/Ocean)	<input type="checkbox"/> <b>C</b>	<b>B17</b>
	<input type="checkbox"/> <b>L</b>	
	<input type="checkbox"/> <b>O</b>	
Outfall Channel	<input type="checkbox"/>	<b>B18</b>
Storm Drain System	<input checked="" type="checkbox"/>	<b>B19</b>
<b>Outfall Components</b>		
Pervious Berm	<input type="checkbox"/>	<b>B20</b>
Riprap Pad	<input type="checkbox"/>	<b>B21</b>



## 7. Maintenance

### Maintenance Frequency/Maintain Records

- a. Inspect annually. Preferably prior to the rainy season.
- b. Clean and maintain as necessary. Refer to Activity 125 for conditions when maintenance is needed.
- c. Keep a record of inspections, maintenance, and repairs.

### Maintenance Guide/Maintenance Actions

The ODOT Routine Road Maintenance Water Quality and Habitat Guide (the *Blue Book*) outlines the standard maintenance actions for water quality facilities under Activity 125.

There are standard maintenance tables for standard ODOT designs. The maintenance tables describe the maintenance component, the defect or problem, the condition when maintenance is needed, and the recommended maintenance to correct the problem. Use the following tables to maintain ODOT filter strips and bioslopes:

- Table 1 (General Maintenance): Contains general maintenance and inspection guidelines that are applicable to all ODOT water quality facilities
- Table 4 (Water Quality Filter Strips)
- Table 5 (Water Quality Bioslopes)

The ODOT Maintenance Guide can be viewed at the following website:

<http://www.oregon.gov/ODOT/HWY/OOM/pages/mguide.aspx>

The *Blue Book* can be viewed at the following website:

[http://www.oregon.gov/ODOT/Maintenance/Documents/blue\\_book.pdf](http://www.oregon.gov/ODOT/Maintenance/Documents/blue_book.pdf)

## 8. Limitations

Filter strips and bioslopes are NOT designed to allow the use of heavy equipment. Vehicles entering the facility can create depressions (tire ruts), damage vegetation, and damage structural components (e.g. flow spreaders). These conditions may result in poor treatment and drainage performance.

## 9. Waste Material Handling

Material removed from the facility is defined as waste by the Department of Environmental Quality (DEQ). Refer to the road waste section of the ODOT Maintenance Yard Environmental Management System (EMS) Policy and Procedures Manual for disposal options:

<http://www.oregon.gov/ODOT/HWY/OOM/pages/ems.aspx>

Contact any of the following for more detailed information about management of waste materials found on site:

ODOT Clean Water Unit	(503) 986-3008
ODOT Statewide Hazmat Coordinator	(503) 667-7442
ODOT Region 1 Hazmat Coordinator	(503) 731-8290
ODOT Region 2 Hazmat Coordinator	(503) 986-2647
ODOT Region 3 Hazmat Coordinator	(541) 957-3594
ODOT Region 4 Hazmat Coordinator	(541) 388-6186
ODOT Region 5 Hazmat Coordinator	(541) 963-1590
ODEQ Northwest Region Office	(503) 229-5263

## **A Appendix A – Site Specific Operational Plan**

### **Contents:**

**Operational Plan: DFI D00635**

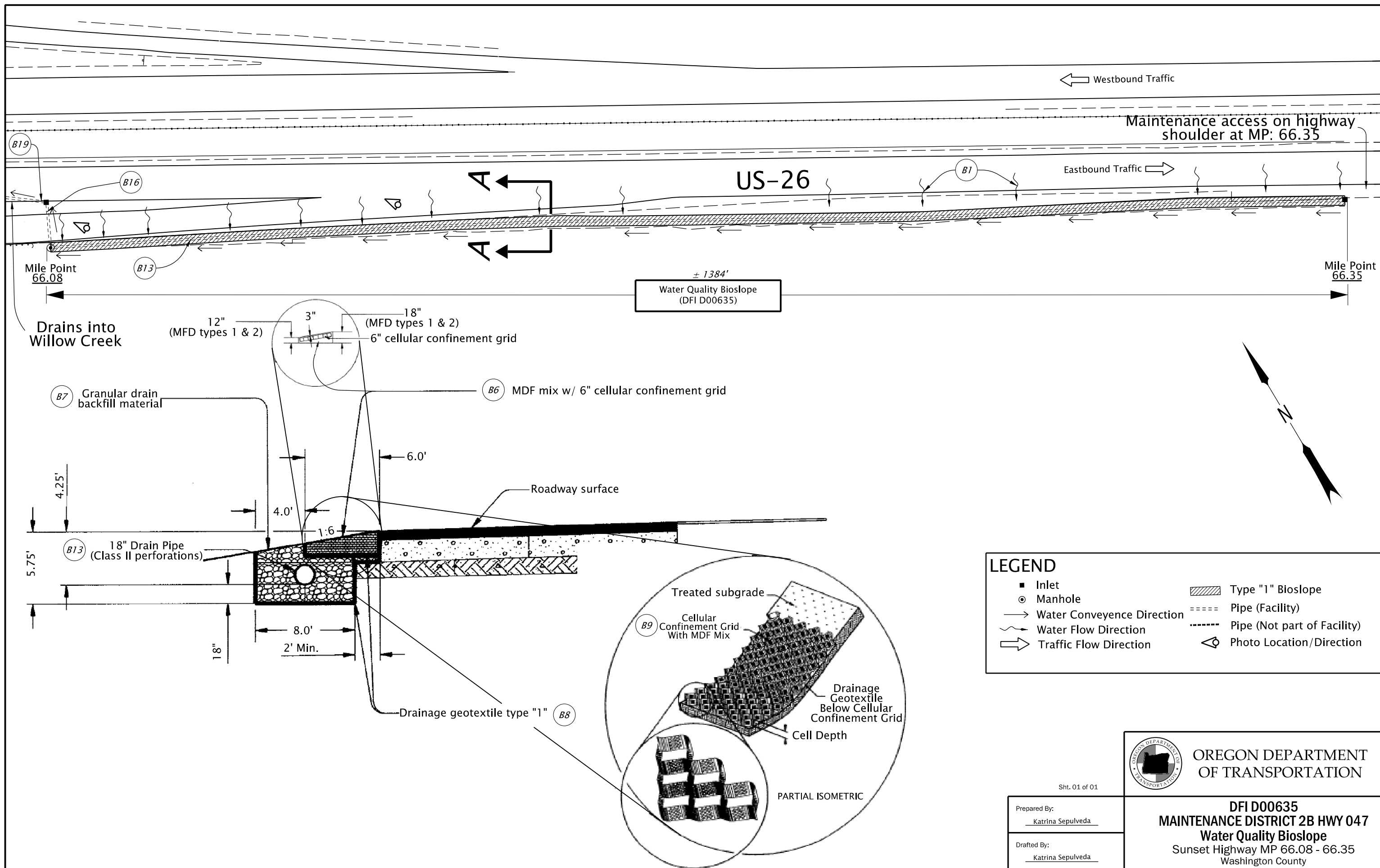

LEGEND			
■	Inlet	▨	Type "1" Bioslope
⊙	Manhole	----	Pipe (Facility)
→	Water Conveyence Direction	- - - -	Pipe (Not part of Facility)
~	Water Flow Direction	◁	Photo Location/Direction
⇨	Traffic Flow Direction		

**OREGON DEPARTMENT OF TRANSPORTATION**

Sht. 01 of 01  
 Prepared By:  
 Katrina Sepulveda  
 Drafted By:  
 Katrina Sepulveda

**DFI D00635**  
**MAINTENANCE DISTRICT 2B HWY 047**  
**Water Quality Bioslope**  
 Sunset Highway MP 66.08 - 66.35  
 Washington County

## **B Appendix B – Project Contract Plans**

### **Contents:**

**Site Specific Subset of Project Contract Plan 43V-086**

INDEX OF SHEETS	
SHEET NO.	DESCRIPTION
1	Title Sheet
1A	Index Of Sheets Cont'd.
1A-2	Std. Drg. Nos.

STATE OF OREGON  
DEPARTMENT OF TRANSPORTATION

PLANS FOR PROPOSED PROJECT

GRADING, DRAINAGE, STRUCTURES, PAVING, SIGNING, ILLUMINATION,  
SIGNALS & ROADSIDE DEVELOPMENT

**US26: NW 185TH AVE - CORNELL ROAD SEC.**

**SUNSET HIGHWAY  
WASHINGTON COUNTY**

APRIL 2010

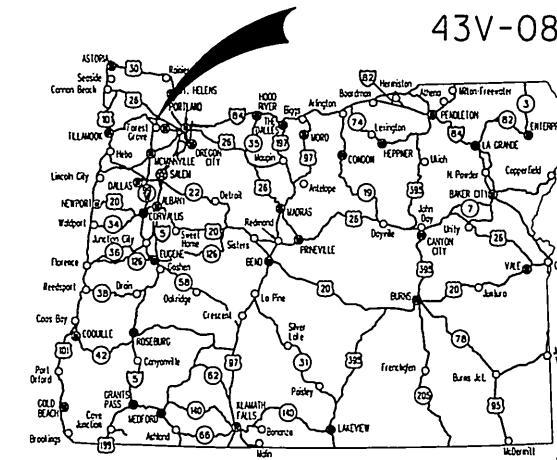

Overall Length Of Site - 2.10 Miles

**ATTENTION:**  
Oregon Law Requires You To Follow Rules Adopted By The Oregon Utility Notification Center. Those Rules Are Set Forth In OAR 952-001-0010 Through OAR 952-001-0090. You May Obtain Copies Of The Rules By Calling The Center. (Note: The Telephone Number For The Oregon Utility Center Is (503) 232-1987.)

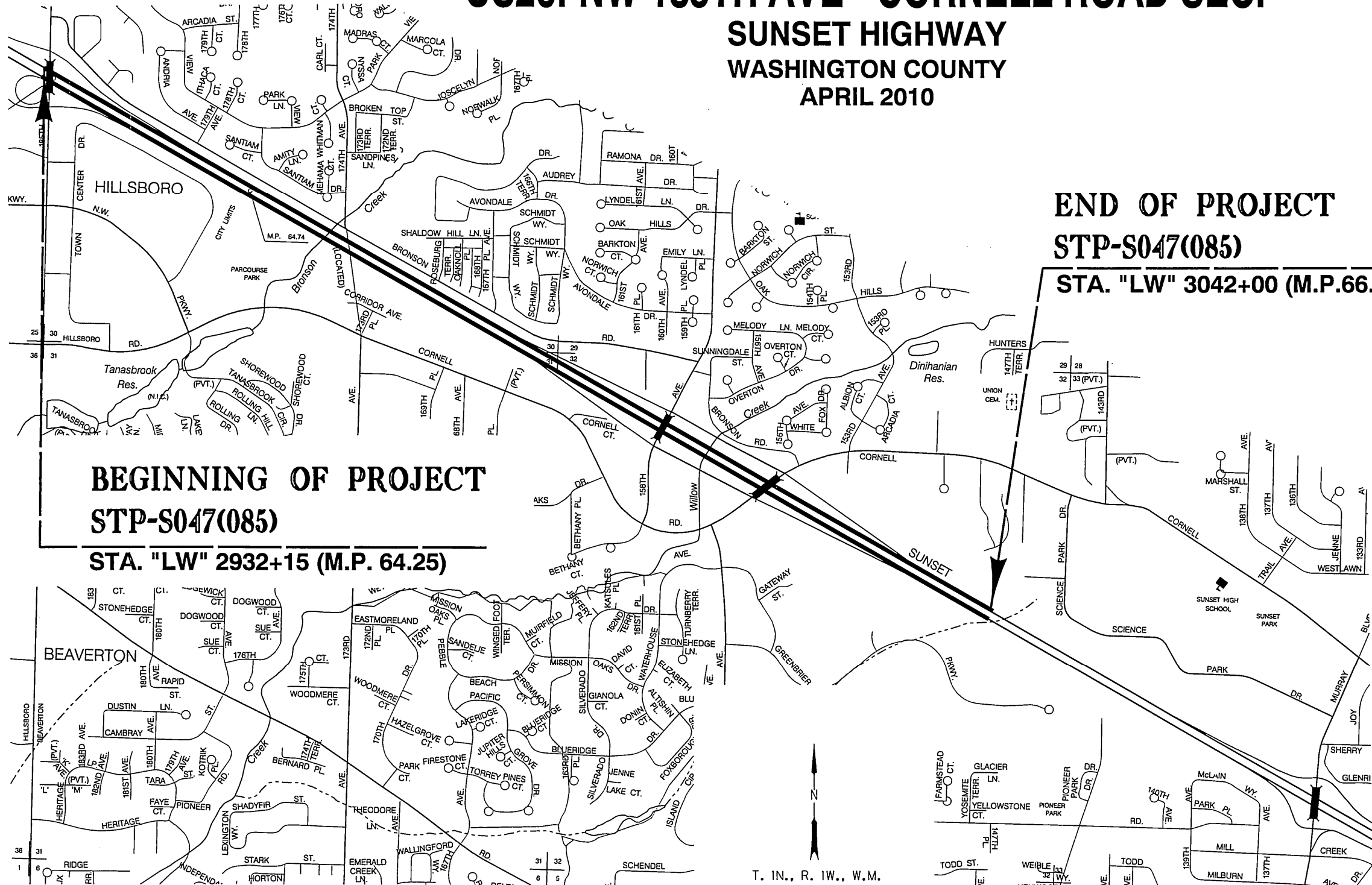

**END OF PROJECT  
STP-S047(085)**

**STA. "LW" 3042+00 (M.P.66.35)**

**BEGINNING OF PROJECT  
STP-S047(085)**

**STA. "LW" 2932+15 (M.P. 64.25)**

LET'S ALL  
WORK TOGETHER  
TO MAKE THIS  
JOB SAFE

OREGON TRANSPORTATION COMMISSION  
Gail Achterman CHAIR  
Michael Nelson VICE-CHAIR  
Janice Wilson COMMISSIONER  
Alan Brown COMMISSIONER  
David Lohman COMMISSIONER  
Matthew L. Garrett DIRECTOR OF TRANSPORTATION

These plans were developed using ODOT design standards. Exceptions to these standards, if any, have been submitted and approved by the ODOT Chief Engineer or their delegated authority.

By: *Naveen G. Chandra*  
Signature & date 2/8/10

Naveen G. Chandra P.E. - R1 Project Delivery Manager

Print name and title

*[Signature]*  
Concurrence by ODOT Chief Engineer

**US26: NW 185TH AVE - CORNELL ROAD SEC.  
SUNSET HIGHWAY  
WASHINGTON COUNTY**

FEDERAL HIGHWAY ADMINISTRATION	PROJECT NUMBER	SHEET NO.
OREGON DIVISION	STP-S047(085)	1



INDEX OF SHEETS, CONT'D.	
SHEET NO.	DESCRIPTION
2, 2A, 2A-2 Thru 2A-16	Typical Sections
2B, 2B-2 Thru 2B-3	Details
2C, 2C-2 Thru 2C-24	Traffic Control Plans
2C-25 Thru 2C-31	Detour Plan
2D, 2D-2	Pipe Data Sheet
3	Alignment
3A	General Construction
3B	Drainage & Utilities
3C	Drainage Profile
4	Alignment
4A	General Construction
4B	Drainage & Utilities
4C	Drainage Profile
5	Alignment
5A	General Construction
5B	Drainage & Utilities
5C	Drainage Profile
6	Alignment
6A	General Construction
6B	Drainage & Utilities
6C	Drainage Profile
7	Alignment
7A	General Construction
7B	Drainage & Utilities
6C	Drainage Profile
8	Alignment
8A	General Construction
8B	Drainage & Utilities
8C	Drainage Profile
9	Alignment
9A	General Construction
9B	Drainage & Utilities
9C	Drainage Profile
10	Alignment
10A	General Construction
10B	Drainage & Utilities
10C	Drainage Profile
11	Alignment
11A	General Construction
11B	Drainage & Utilities
11C	Drainage Profile
12	Alignment
12A	General Construction
12B	Drainage & Utilities
12C	Drainage Profile

INDEX OF SHEETS, CONT'D.	
SHEET NO.	DESCRIPTION
<b>PERMANENT PAVEMENT MARKERS</b>	
ST	Striping Details
ST-2 Thru ST-11 Incl.	Striping Plan
<b>GEO/HYDRO</b>	
GA, GA-2 Thru GA-11 Incl.	Erosion Control Plan
GA-12 Thru GA-15 Incl.	Erosion Control Details
<b>ROADSIDE DEVELOPMENT</b>	
GN, GN-2 Thru GN-8	Roadside Development Details
GN-9 Thru GN-12	Roadside Development Plan

  

DRAWING NO.	SHEET NO.	DESCRIPTION
83488	GB	Geotechnical Data
83495	GB-2	Geotechnical Data
83498	GB-3	Geotechnical Data
83499	GB-4	Geotechnical Data
<b>BRIDGE NO. 21329 - NORTH RETAINING WALL</b>		
83489	GC	Retaining Wall Plan & Profile
83490	GC-2	Retaining Wall Plan & Profile
83491	GC-3	Retaining Wall Plan & Profile
83492	GC-4	Retaining Wall Plan & Profile
<b>BRIDGE NO. 21328 - SOUTH RETAINING WALL</b>		
83496	GC-5	Retaining Wall Plan & Profile
83493	GC-6	North Retaining Wall Details
83494	GC-7	South Retaining Wall Details
83497	GC-8	Retaining Wall Details
GJ, GJ-2 Thru GJ-3		Water Quality Details

INDEX OF SHEETS, CONT'D.	
DRAWING NO.	DESCRIPTION
<b>PERMANENT SIGNING</b>	
S-11907 Thru S-11925 Incl.	Sign Installation Plan
S-11926 Thru S-11935 Incl.	Sign Details
S-11936 Thru S-11944 Incl.	Sign Post & Data Table
<b>ILLUMINATION</b>	
I-1688 Thru I-1698 Incl.	Illumination Plan
I-1699	Illumination Details
<b>TRAFFIC SIGNALS</b>	
ITS-889 Thru ITS-895 Incl.	Communication Plan
15564 Thru 15568 Incl.	Ramp Meter Plan
15569	Ramp Meter Details
<b>AUTOMATED TRAFFIC RECORDER #34-010</b>	
TDS-485	Base Mounted Service Cabinet
TDS-34-010A	Traffic Recorder Plan Legend
TDS-34-010B	Traffic Recorder Loop Details
<b>SIGN SUPPORTS</b>	
<b>BRIDGE NO. 08404A - NW MURRAY BLVD.</b>	
83409	Plan, Elevation & Section
83410	Details
<b>BRIDGE NO. 08910A - NW CORNELL RD.</b>	
83411	Plan, Elevation & Section
<b>BRIDGE NO. 16966 - NW BETHANY BLVD.</b>	
83412	Plan, Elevation & Section
<b>CANTILEVER SIGN STRUCTURES</b>	
S-11945	Plan & Elevation

<b>US26: NW 185TH AVE - CORNELL ROAD SEC.</b> SUNSET HIGHWAY WASHINGTON COUNTY		
FEDERAL HIGHWAY ADMINISTRATION	PROJECT NUMBER	SHEET NO.
OREGON DIVISION	STP-SO47(085)	1A

Sec. 32, T. 1 N., R. 1 W., W.M.

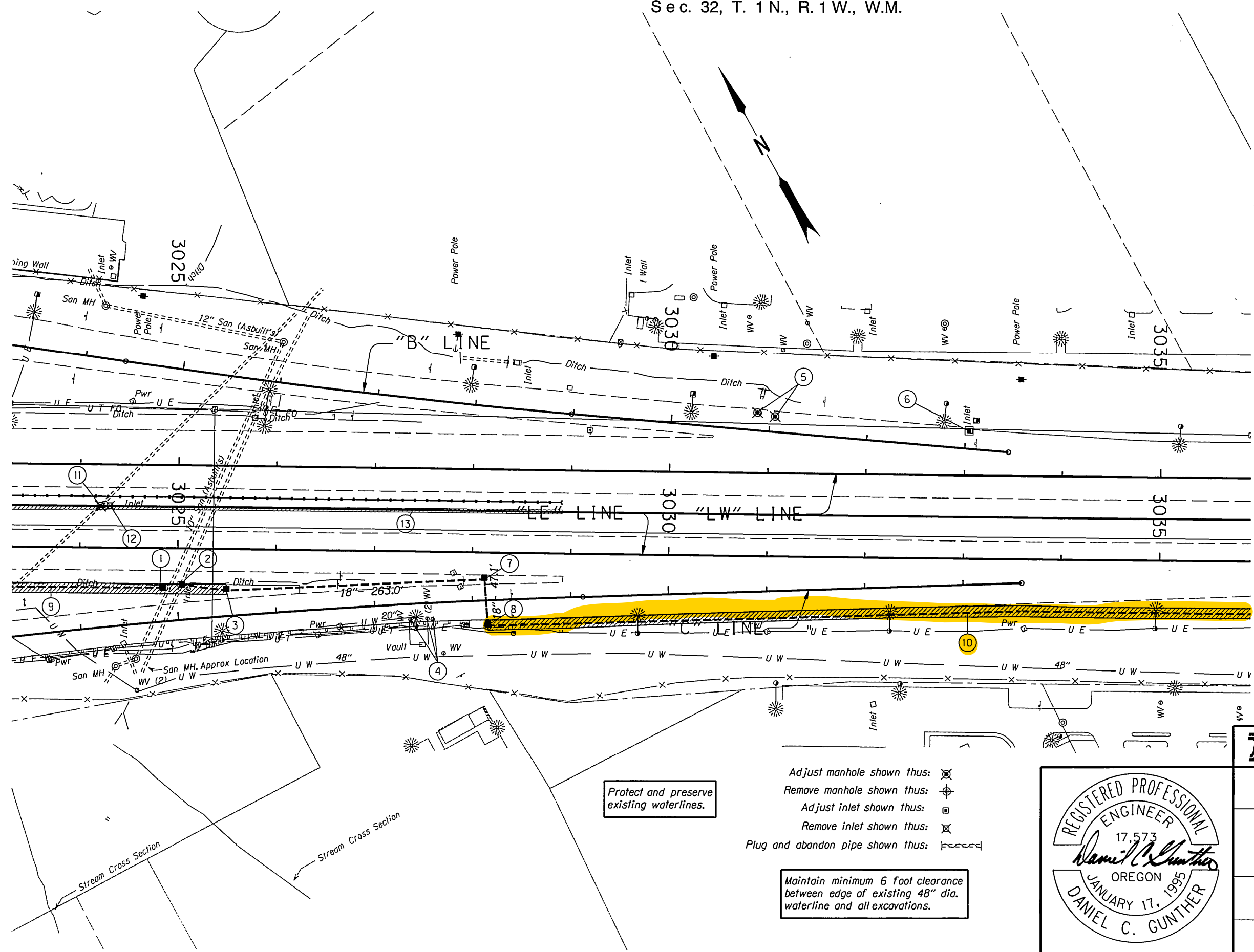

- ① Sta. "LE" 3024+82.28, 40.0 Rt.  
Const. type "PVC" inlet  
(For details, see sht. GJ-2)
- ② Sta. "LE" 3025+02.67, 36.41 Rt.  
Connect drain pipe to exist. inlet  
F.L. 210.00 into inlet
- ③ Sta. "LE" 3025+50.00, 42.00 Rt.  
Const. type "PVC" inlet  
Inst. 18" drain pipe - 47.6'  
5' depth  
(For details, see sht. GJ-2)
- ④ Adjust water valve to grade - 3  
(By others)
- ⑤ Adjust manhole - 2
- ⑥ Adjust inlet
- ⑦ Sta. "LE" 3028+12.59, 27.21 Rt.  
Const. type "PVC" inlet  
Inst. 18" sew. pipe - 263.0'  
5' depth  
(For details, see sht. GJ-2)
- ⑧ Sta. "LE" 3028+16.61, 74.10 Rt.  
Const. storm sewer pollution control  
manhole, (Mod.)  
Inst. 18" sew. pipe - 47.1'  
5' depth  
Trench resurf. - 16 sq.yd.  
(For details, see sht. GJ-3)
- ⑨ See sht. 8B note 15
- ⑩ Sta. "LE" 3028+16.61  
to Sta. "LE" 3041+99.97  
Const. MFD - 1384' (Type 1)
- ⑪ Sta. "LE" 3024+20.44, Lt.  
Connect median drain pipes to MH  
Adjust manhole
- ⑫ Sta. "LE" 3024+30.39, 42.36 Lt.  
Remove inlet
- ⑬ See sht. 10B note 9  
Const. median drain

Protect and preserve existing waterlines.

- Adjust manhole shown thus: [Symbol]
- Remove manhole shown thus: [Symbol]
- Adjust inlet shown thus: [Symbol]
- Remove inlet shown thus: [Symbol]
- Plug and abandon pipe shown thus: [Symbol]

Maintain minimum 6 foot clearance between edge of existing 48" dia. waterline and all excavations.

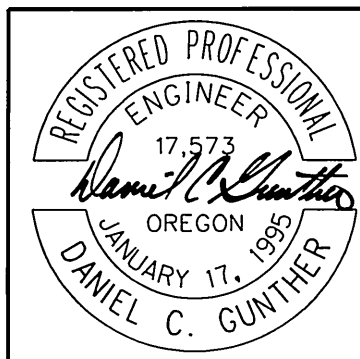

RENEWAL DATE: 6-30-2011

<b>OREGON DEPARTMENT OF TRANSPORTATION</b>	
<b>REGION 1 - GEO/HYDRO UNIT</b>	
US26: NW 185TH AVE - CORNELL ROAD SEC. SUNSET HIGHWAY WASHINGTON COUNTY	
Reviewed By - Bruce Council Designed By - Dan Gunther Drafted By - Dan Gunther	
<b>DRAINAGE &amp; UTILITIES</b>	SHEET NO. <b>11B</b>

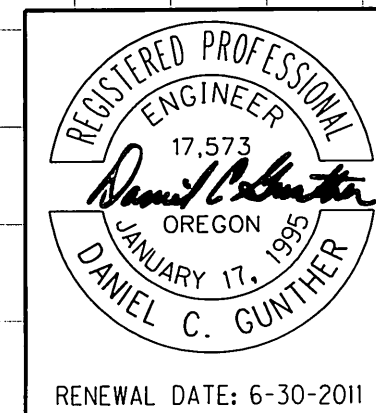
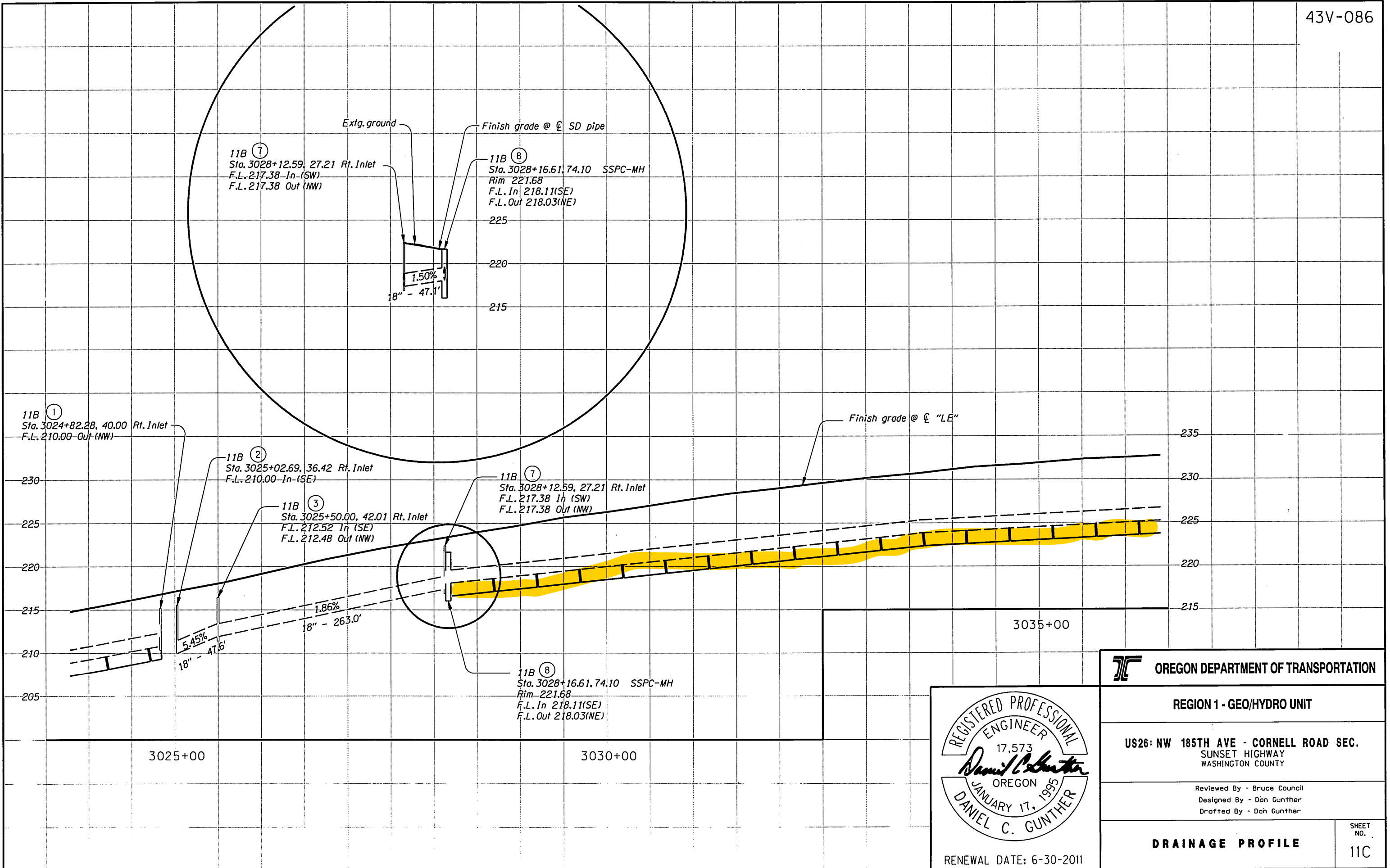

<b>OREGON DEPARTMENT OF TRANSPORTATION</b>	
<b>REGION 1 - GEO/HYDRO UNIT</b>	
<b>US26: NW 185TH AVE - CORNELL ROAD SEC.</b> SUNSET HIGHWAY WASHINGTON COUNTY	
Reviewed By - Bruce Council Designed By - Dan Gunther Drafted By - Dan Gunther	
<b>DRAINAGE PROFILE</b>	SHEET NO. <b>11C</b>

- ① Sta. "LE" 3041+99.97, 42.02 Rt.  
Const. type "PVC" inlet  
(For details, see sht. GJ-2)
- ② Adjust inlet - 5
- ③ See sht. 11B note 10  
Const. MFD

**END OF PROJECT**  
STA. "LW" 3042+00 (M.P. 66.35)

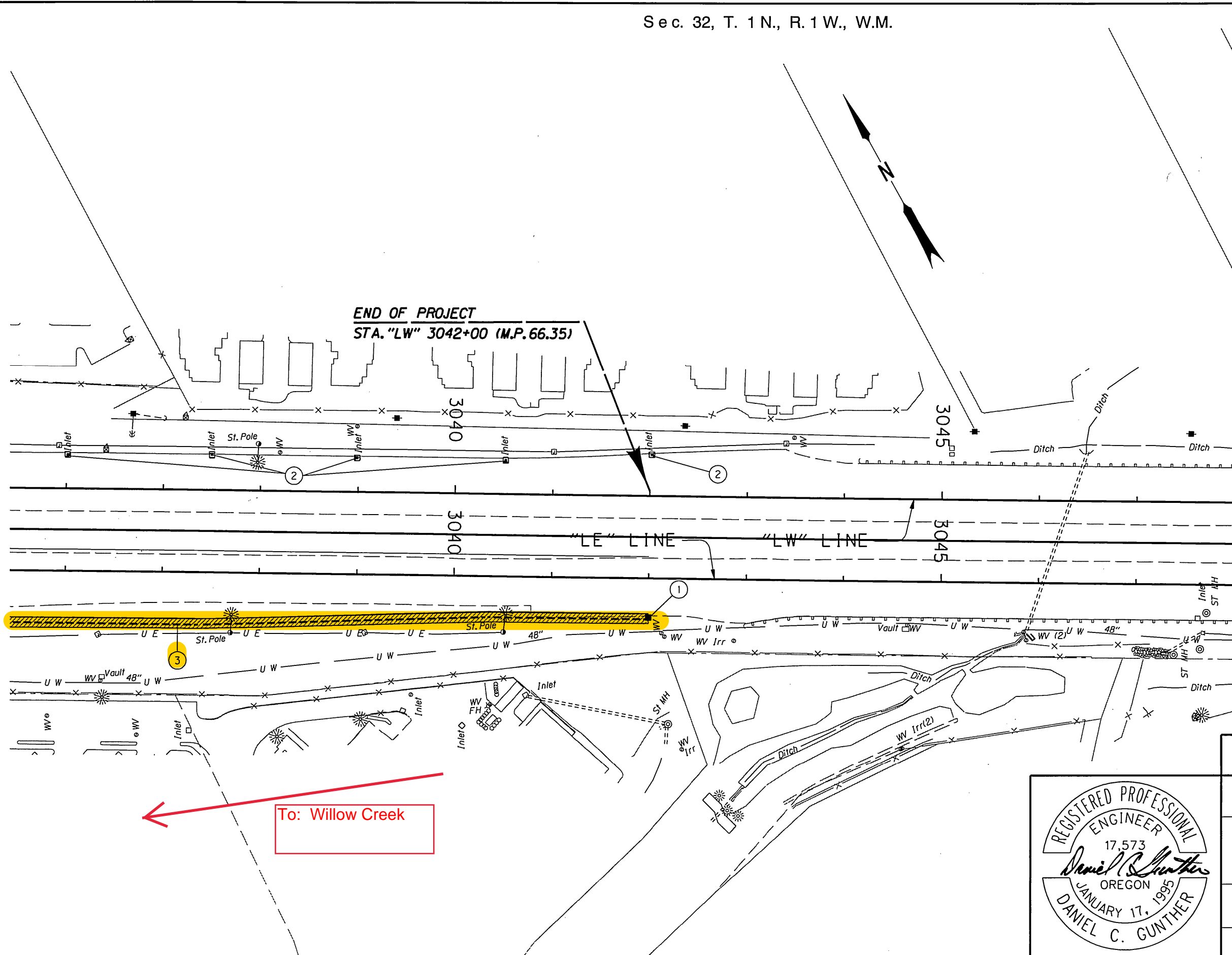

Protect and preserve existing waterlines.

- Adjust manhole shown thus:
- Remove manhole shown thus:
- Adjust inlet shown thus:
- Remove inlet shown thus:
- Plug and abandon pipe shown thus:

Maintain minimum 6 foot clearance between edge of existing 48" dia. waterline and all excavations.

To: Willow Creek

OREGON DEPARTMENT OF TRANSPORTATION	
REGION 1 - GEO/HYDRO UNIT	
US26: NW 185TH AVE - CORNELL ROAD SEC. SUNSET HIGHWAY WASHINGTON COUNTY	
Reviewed By - Bruce Council Designed By - Dan Gunther Drafted By - Dan Gunther	
<b>DRAINAGE &amp; UTILITIES</b>	SHEET NO. <b>12B</b>

REGISTERED PROFESSIONAL  
ENGINEER  
17,573  
*Daniel C. Gunther*  
OREGON  
JANUARY 17, 1995  
DANIEL C. GUNTHER  
RENEWAL DATE: 6-30-2011



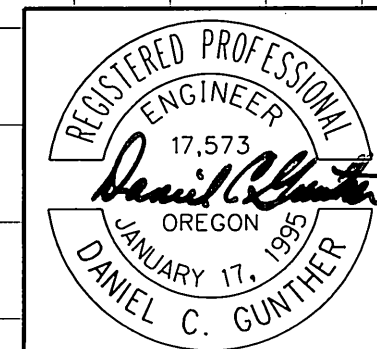
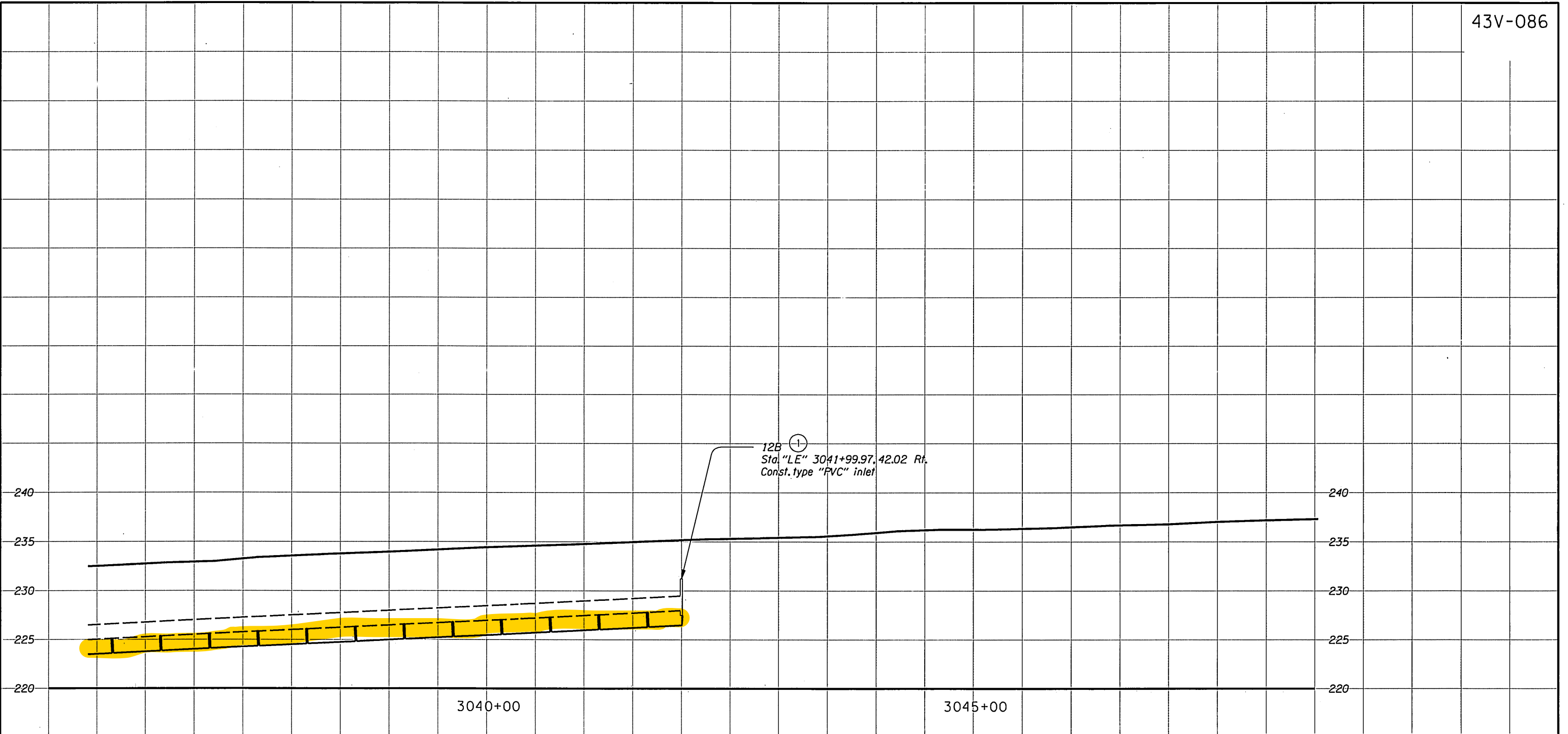

RENEWAL DATE: 6-30-2011

**OREGON DEPARTMENT OF TRANSPORTATION**

**REGION 1 - GEO/HYDRO UNIT**

**US26: NW 185TH AVE - CORNELL ROAD SEC.**  
SUNSET HIGHWAY  
WASHINGTON COUNTY

Reviewed By - Bruce Council  
Designed By - Dan Gunther  
Drafted By - Dan Gunther

**DRAINAGE PROFILE**

SHEET NO.

12C

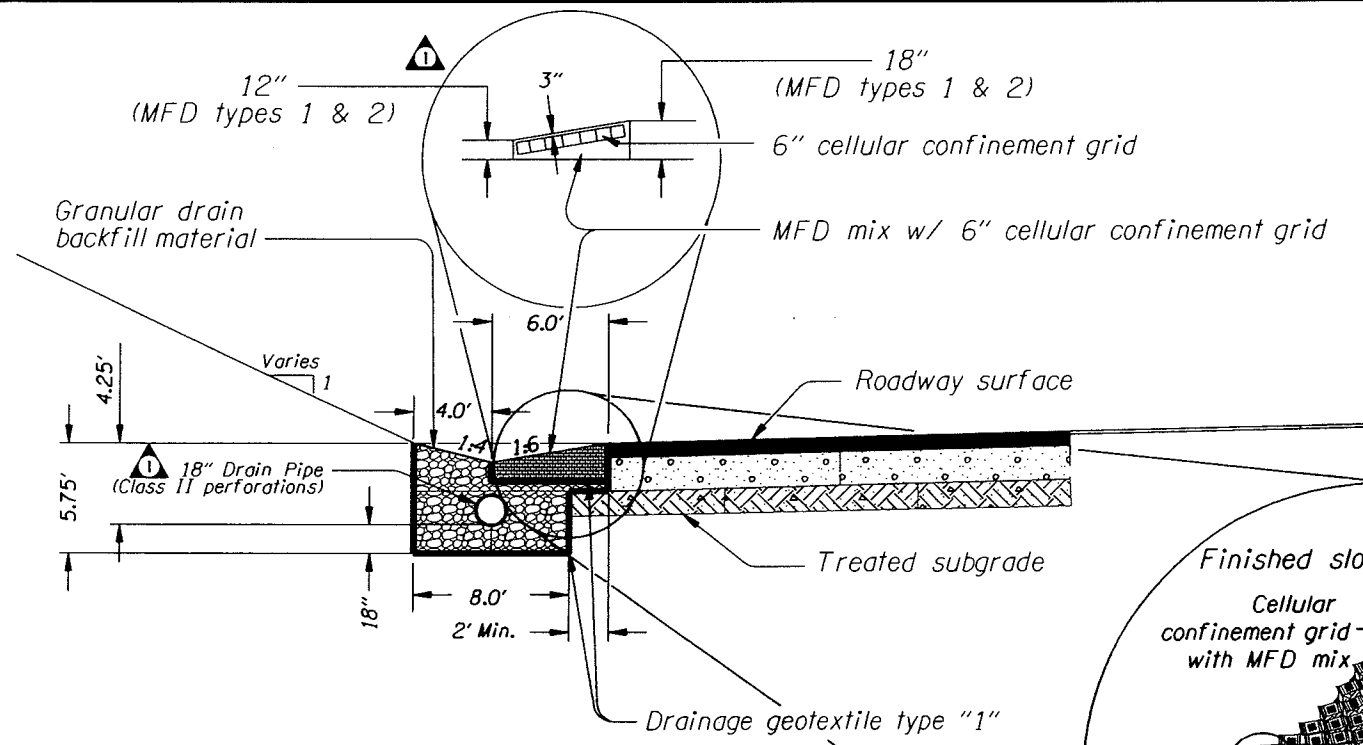

**MFD (TYPE 1) SECTION  
DITCH CONFIGURATION**

Horiz. Scale: 1"=10'  
Vert. Scale: 1"=10'

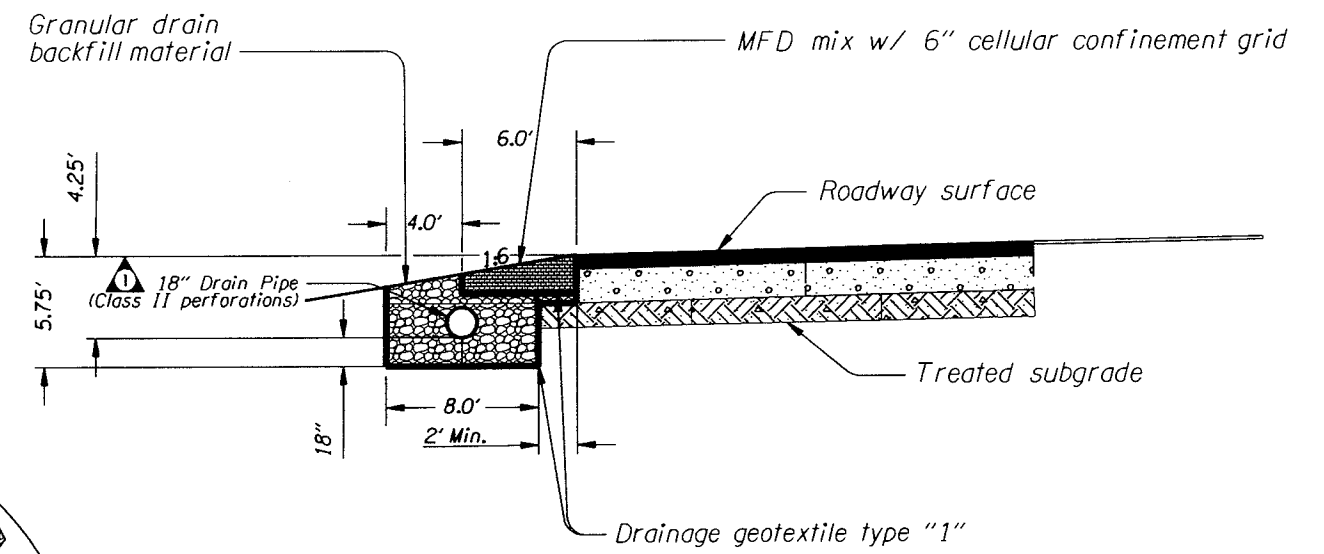
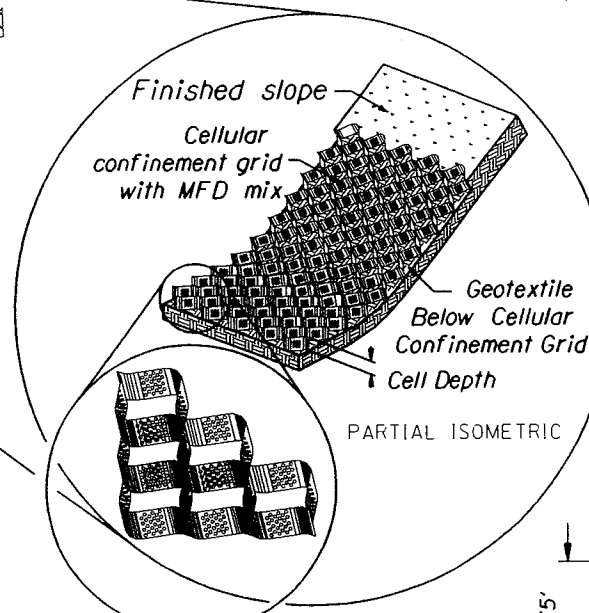

**MFD (TYPE 1) SECTION  
SLOPE CONFIGURATION**

Horiz. Scale: 1"=10'  
Vert. Scale: 1"=10'

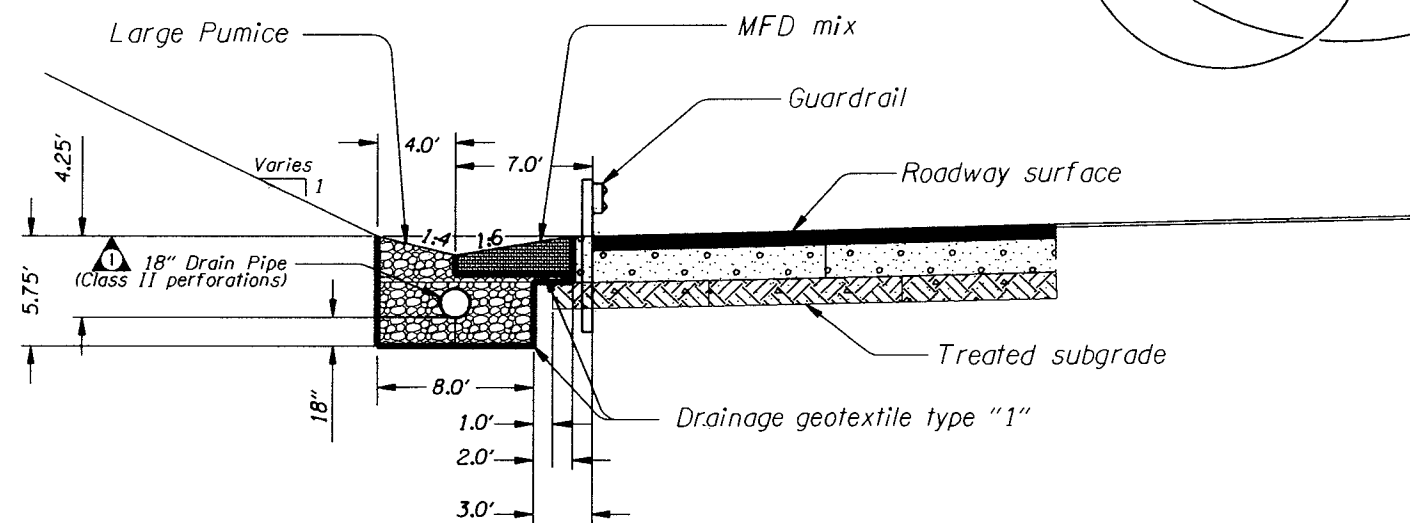

**MFD (TYPE 2) SECTION  
DITCH CONFIGURATION**

Horiz. Scale: 1"=10'  
Vert. Scale: 1"=10'

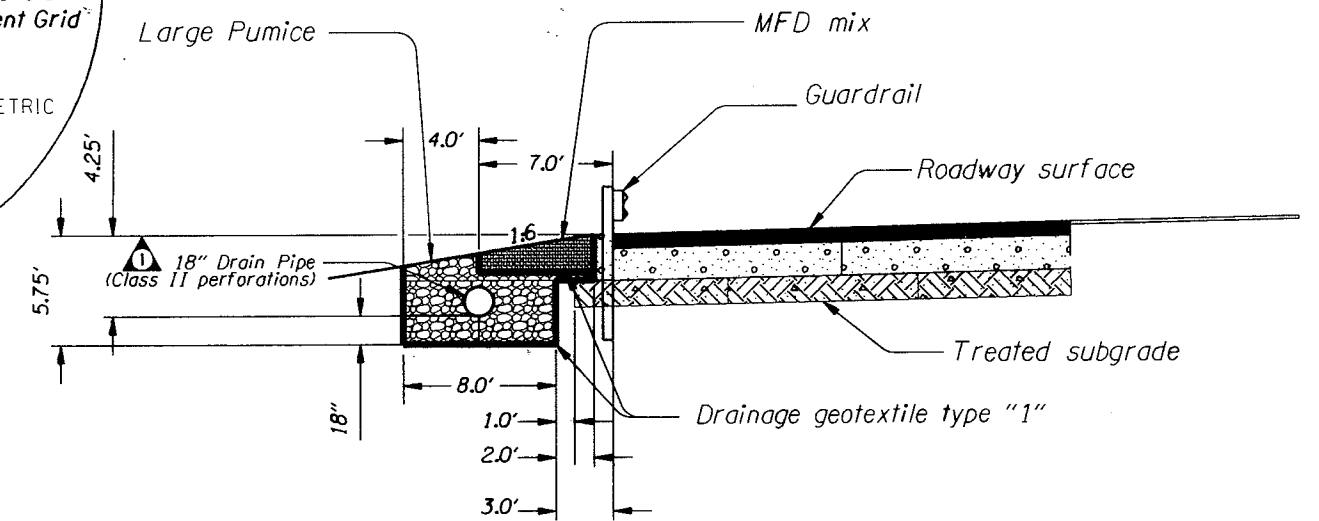

**MFD (TYPE 2) SECTION  
SLOPE CONFIGURATION**

Horiz. Scale: 1"=10'  
Vert. Scale: 1"=10'

**OREGON DEPARTMENT OF TRANSPORTATION**

**REGION 1 - GEO/HYDRO UNIT**

**US26: NW 185TH AVE - CORNELL ROAD SEC.  
SUNSET HIGHWAY  
WASHINGTON COUNTY**

Reviewed By - Bruce Council  
Designed By - Dan Gunther  
Drafted By - Dan Gunther

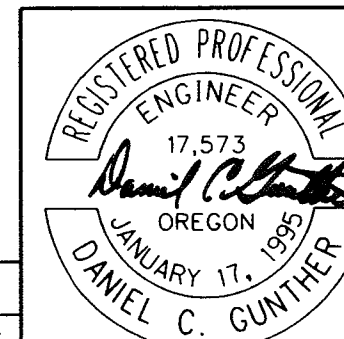

RENEWAL DATE: 6-30-2011

No.	DATE	REVISIONS	BY
1	04-01-10	Added drawing insert	D.C.G.
2	04-01-10	Added pipe callout	D.C.G.

**WATER QUALITY DETAILS**  
SHEET NO. GJ