

OPERATION & MAINTENANCE MANUAL

DFI No. : D00360

Facility Type: Water Quality Manhole



JULY, 2011

INDEX

1. IDENTIFICATION..... 1

2. FACILITY CONTACT INFORMATION..... 1

3. CONSTRUCTION..... 1

4. STORM DRAIN SYSTEM AND FACILITY OVERVIEW 2

5. FACILITY HAZ MAT SPILL FEATURE(S)..... 4

6. AUXILIARY OUTLET (HIGH FLOW BYPASS)..... 4

7. MAINTENANCE REQUIREMENTS..... 4

8. WASTE MATERIAL HANDLING..... 5

APPENDIX A: Operational Plan and Profile Drawing(s)

APPENDIX B: ODOT Project Plan Sheets

1. Identification

Drainage Facility ID (DFI): **D00360**
Facility Type: Water Quality Manhole
Construction Drawings: (V-File Number) 37V-041
Location: District: 2B (Old 2A)
Highway No.: 047
Mile Post: 66.77 (beg./end)
Description: This facility is located on the south side of eastbound US 26 (Hwy 047), and is separated from the travel lanes and shoulder by a guardrail.

2. Facility Contact Information

Contact the Engineer of Record, Region Technical Center, or Geo-Environmental's Senior Hydraulics Engineer for:

- Operational clarification
- Maintenance clarification
- Repair or restoration assistance

Engineering Contacts:

Region Technical Center Hydro Unit Manager

Or

Geo-Environmental Senior Hydraulics Engineer (503) 986-3365.

3. Construction

Engineer of Record: ODOT Designer – Region 1 Tech. Center, Bruce Council, (503) 731-8319

Facility construction: 2004
Contractor: Mowatt Construction Company

4. Storm Drain System and Facility Overview

This water quality manhole is an underground flow-through structure with a settling or separation unit designed to treat stormwater runoff by removing sediment and other pollutants. The system is an ODOT internally designed facility, providing pollution control and treatment through sedimentation by separating contaminants from the stormwater runoff. It is designed to treat stormwater runoff by separating contaminants, such as floatables (trash, debris and oil) and settleable particles, like sediment, from stormwater.

Inflows enter the manhole from the inlet pipe and subsequently go into an open weir channel. From the open weir channel, the treatment flow drops down into the manhole sump (its treatment zone) via a vertical pipe with an L-shaped lower portion. In the treatment zone, the treatment flow volume accumulates up to the elevation of the bottom of the open weir channel.

Contaminants separate from the treatment flow volume due to density differences. Contaminants less dense than water float to the top of the volume, and contaminants denser than water sink. As new flow enters the treatment zone, the input displaces old treatment flow and pushes it up another vertical pipe (which has an L-shaped lower portion.) This pipe leads to the open weir channel, which conveys the outflow to the manhole's outlet pipe.

This water quality facility treats sheet flow runoff from the eastbound travel lanes and shoulder of US 26 (Hwy 047). These flows are conveyed by a 12-inch diameter pipe into the facility. After treatment through the manhole, the water outfalls through a 12-inch diameter pipe into a water quality biofiltration swale (DFI D00167) located south of the water quality manhole facility.

A. Maintenance equipment access:

This facility is located behind a metal guardrail which runs parallel to the right shoulder along the eastbound travel lane of US 26 (Hwy 047). There is a maintenance access pad located just west of the facility that can be utilized for access to this facility.

B. Heavy equipment access into facility:

- Allowed (no limitations)
- Allowed (with limitations)
- Not allowed

C. Special Features:

- Amended Soils
- Porous Pavers
- Liners
- Underdrains



Photo 1: Water Quality Manhole looking eastbound on US 26 (Hwy 047).

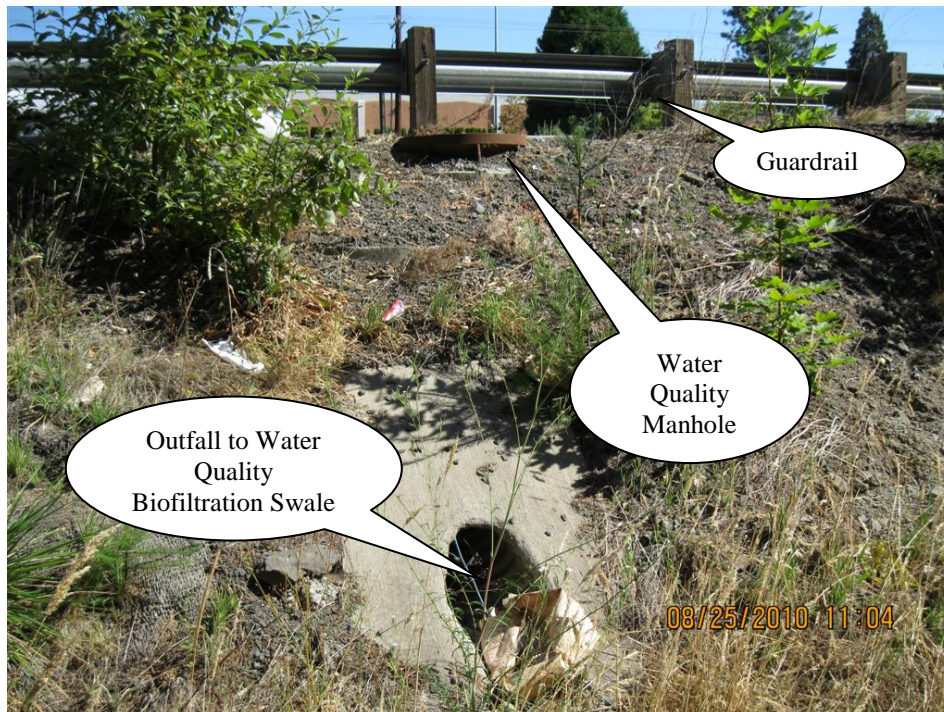

Photo 2: Water Quality Manhole and outfall pipe into Water Quality Biofiltration Swale (D00167).

5. Facility Haz Mat Spill Feature(s)

The water quality manhole can be used to store a volume of liquid by blocking the 12-inch diameter outlet pipe located at the outlet of the water quality manhole. This pipe is noted as point B in the Operational Plan; Appendix A.

6. Auxiliary Outlet (High Flow Bypass)

Auxiliary Outlets are provided if the primary outlet control structure can not safely pass the projected high flows. Broad-crested spillway weirs and over flow risers are the two most common auxiliary outlets used in stormwater treatment facility design. The auxiliary outlet feature is either a part of the facility or an additional storm drain feature/structure.

The auxiliary outlet feature for this facility is:

Designed into facility

The water quality manhole is equipped with a high flow weir which serves the facility as the high flow bypass when water flows reach certain levels. The high flow weir used within this facility is a metal angle. Refer to Section A-A in the Operational Plan; Appendix A for further details.

Other, as noted below

7. Maintenance Requirements

Routine maintenance table for non-proprietary stormwater treatment and storage/detention facilities have been incorporated into ODOT's Maintenance Guide. These tables summarize the maintenance requirements for ponds, swales, filter strips, bioslopes, and detention tanks and vaults. Special maintenance requirements in addition to the routine requirements are noted below when applicable.

The ODOT Maintenance Guide can be viewed at the following website:

<http://www.oregon.gov/ODOT/HWY/OOM/MGuide.shtml>

Maintenance requirements for proprietary structures, such as underground water quality manholes and/or vaults with filter media are noted in Appendix C when applicable.

The following stormwater facility maintenance table (See ODOT Maintenance Guide) should be used to maintain the facility outlined in this Operation and Maintenance Manual or follow the Maintenance

requirements outlined in Appendix C when proprietary structure is selected below:

- Table 1 (general maintenance)
- Table 2 (stormwater ponds)
- Table 3 (water quality biofiltration swales)
- Table 4 (water quality filter strips)
- Table 5 (water quality bioslopes)
- Table 6 (detention tank)
- Table 7 (detention vault)
- Appendix C (proprietary structure)
- Special Maintenance requirements:

Note: Special maintenance Requirements Require Concurrence from ODOT SR Hydraulics Engineer.

8. Waste Material Handling

Material removed from the facility is defined as waste by DEQ. Refer to the roadwaste section of the ODOT Maintenance Yard Environmental Management System (EMS) Policy and Procedures Manual for disposal options: <http://egov.oregon.gov/ODOT/HWY/OOM/EMS.shtml>

Contact any of the following for more detailed information about management of waste materials found on site:

ODOT Clean Water Unit	(503) 986-3008
ODOT Statewide Hazmat Coordinator	(503) 229-5129
ODOT Region Hazmat Coordinator	(503) 731-8304
ODEQ Northwest Region Office	(503) 229-5263

Appendix A

Content:

- **Operational Plan and Profile Drawing(s)**

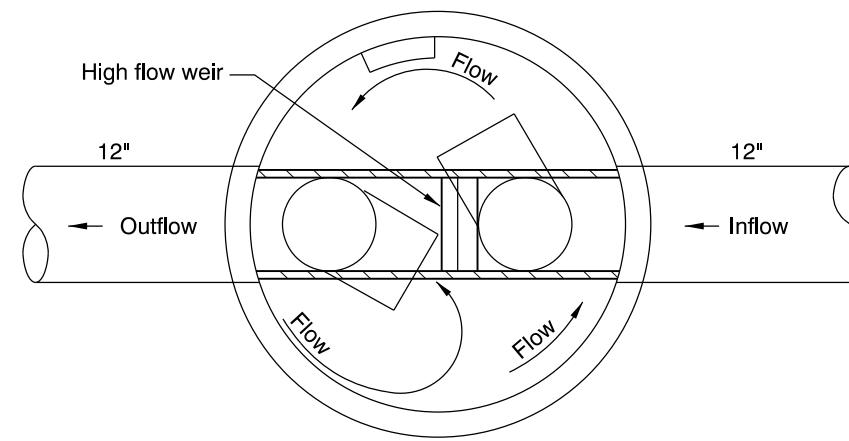
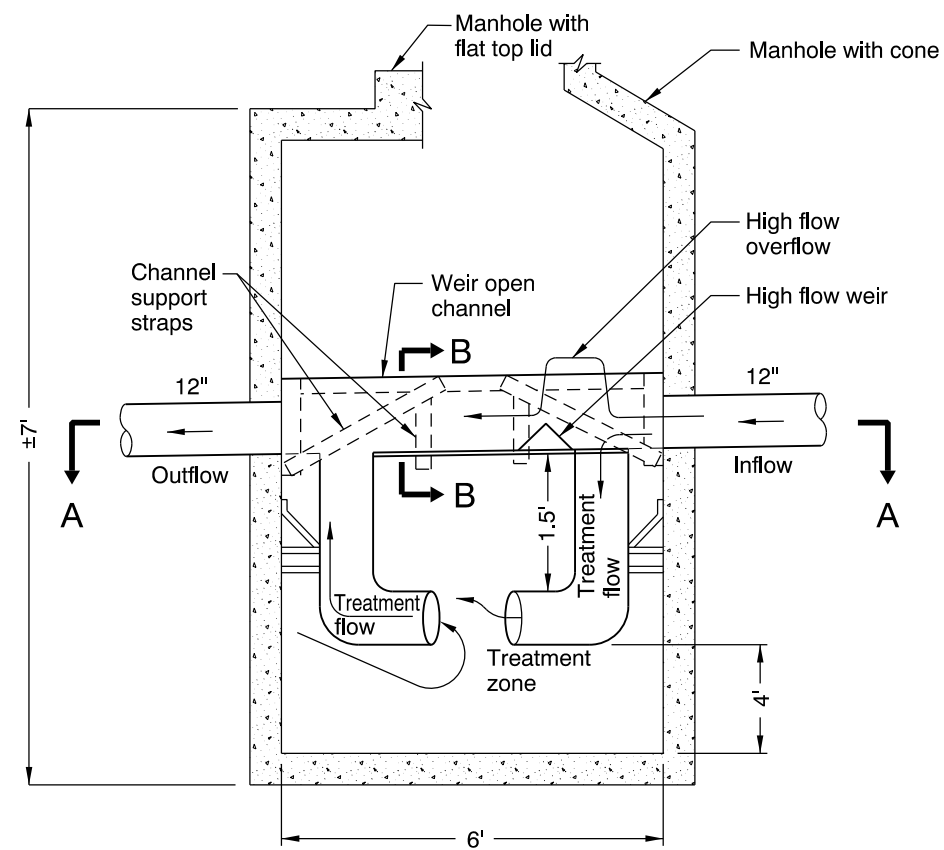
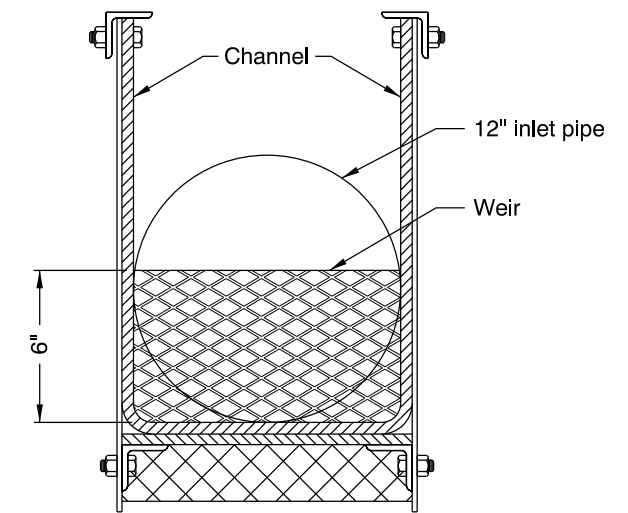
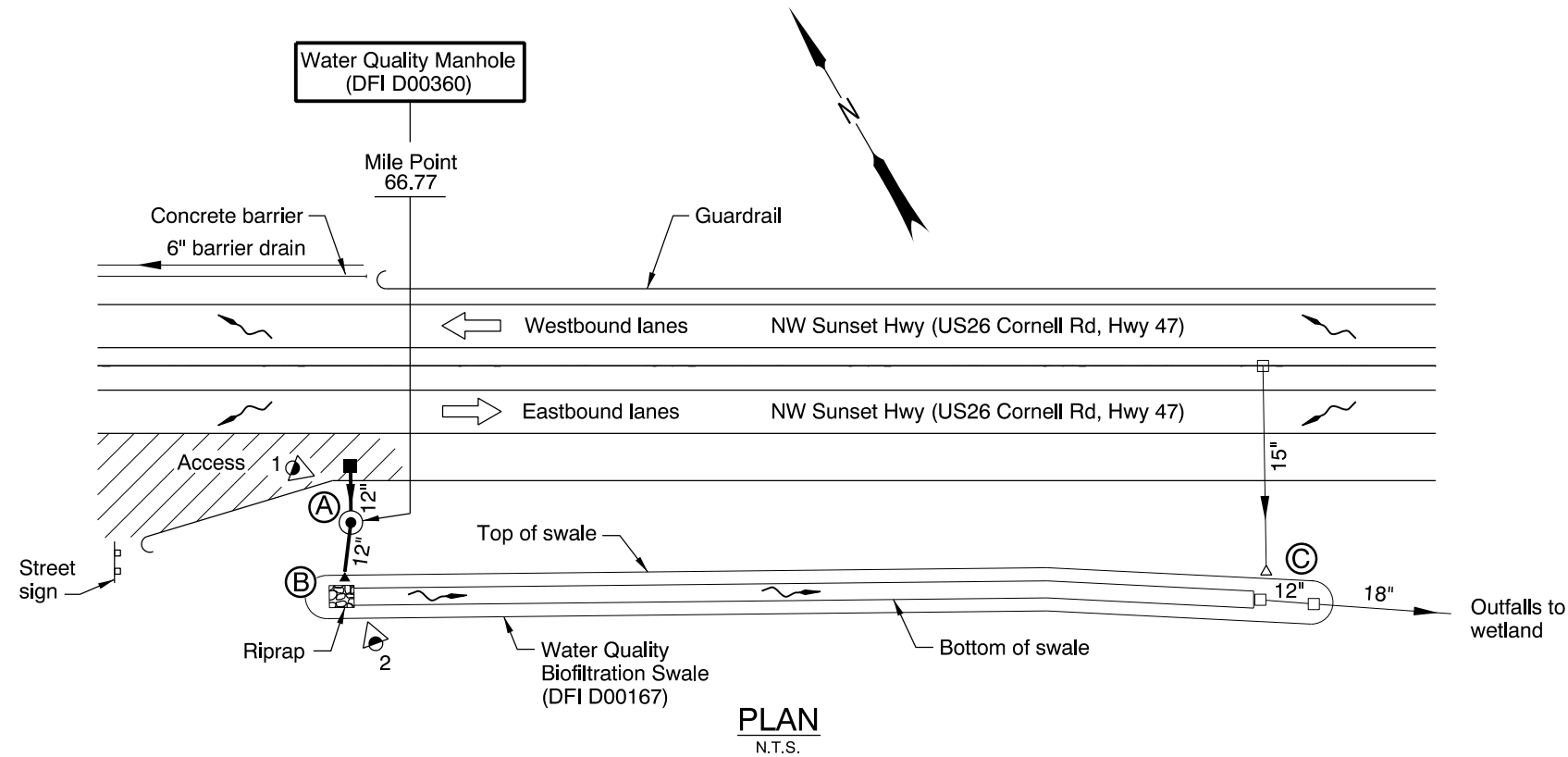

LEGEND:

- Photograph location / direction
- Water Quality Manhole
- Inlet
- Outlet
- Manhole
- Inlet
- Storm Pipe (Facility)
- Storm Pipe
- Conveyance Direction
- Pavement / Facility Flow Path
- Maintenance Access

Sht. 1 of 1

OREGON DEPARTMENT OF TRANSPORTATION

Prepared By: Craig Fox
 Drafted By: S. Wolfer

DFI D00360
MAINTENANCE DISTRICT 2B HWY 47
WATER QUALITY MANHOLE
 SUNSET HIGHWAY MP 66.77
 WASHINGTON COUNTY

Appendix B

Content:

- **ODOT Project Plan Sheets**
 - *Cover/Title Sheet*
 - *Water Quality/Detention Plan Sheets*
 - *Other Details*

STATE OF OREGON
DEPARTMENT OF TRANSPORTATION

PLANS FOR PROPOSED PROJECT
GRADING, DRAINAGE, STRUCTURES, PAVING, SIGNING,
ILLUMINATION, SIGNALS, & ROADSIDE DEVELOPMENT

**US26: CORNELL RD. -
OR217 (BEAVERTON) SEC.**

SUNSET HIGHWAY

WASHINGTON COUNTY
MARCH 2004

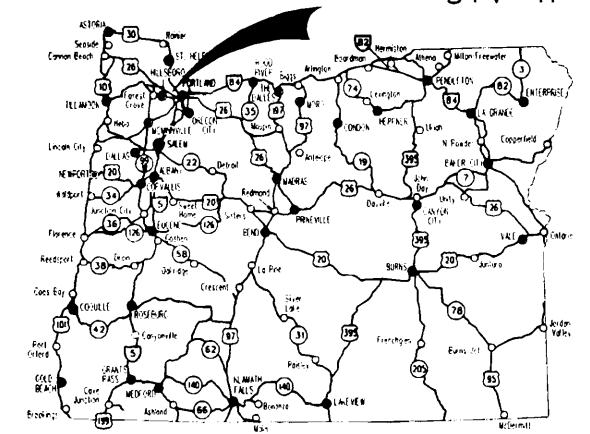

Overall Length Of Project - 6.51 km (4.05 Miles)

INDEX OF SHEETS	
SHEET NO.	DESCRIPTION
1	Title Sheet
1A, 1A-2	Index Of Sheets Cont'd.
1A-3	Std. Drq. Nos.
1B	Sheet Layout
2, 2A, 2A-2 Thru 2A-65 Incl.	Typical Sections
2B, 2B-2 Thru 2B-18 Incl.	Details
2C, 2C-2	Traffic Control Details
2CA, 2CA-2, 2CA-2A, 2CA-3 Thru 2CA-57 Incl.	Traffic Control Plans - Murray Work Area
2CB, 2CB-2 Thru 2CB-12 Incl.	Traffic Control Plans - Cornell Work Area
2D, 2D-2, Thru 2D-12, Incl.	Pipe Data Sheet

ATTENTION:
Oregon Law Requires You To Follow Rules
Adopted By The Oregon Utility Notification
Center. Those Rules Are Set Forth In
OAR 952-001-0010 Through OAR 952-001-0090.
You May Obtain Copies Of The Rules By Calling
The Center. (Note: The Telephone Number For
The Oregon Utility Center Is (503) 232-1987.)



LET'S ALL
WORK TOGETHER
TO MAKE THIS
JOB SAFE

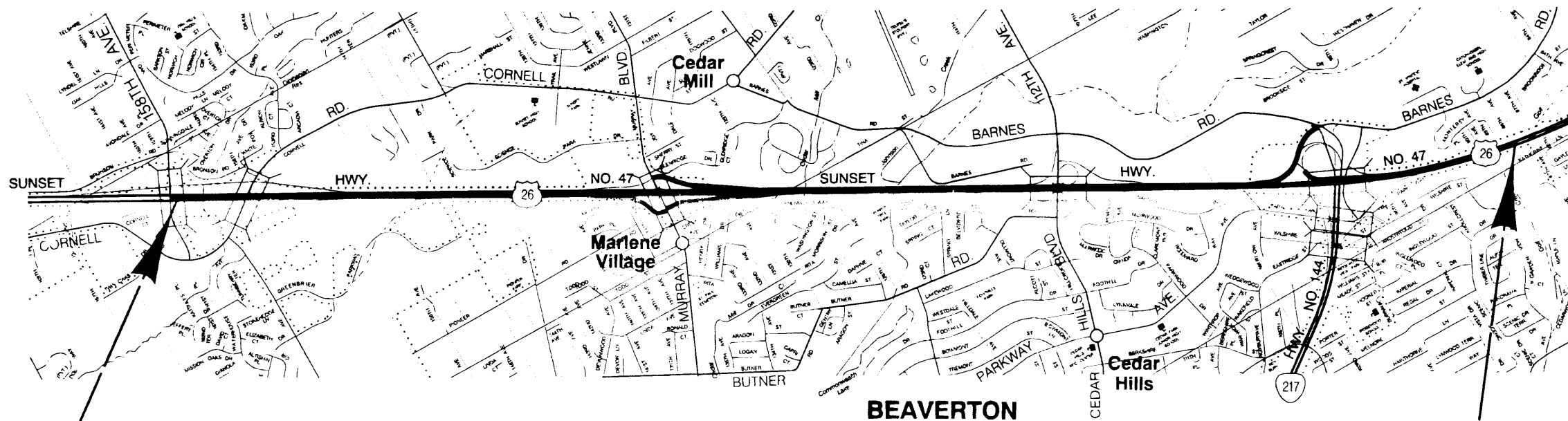

**BEGINNING OF PROJECT
NH-OTIA-S047(052)**

STA. "LW" 91+660.00 (M.P. 65.68)

**END OF PROJECT
NH-OTIA-S047(052)**

STA. "L" 98+160.00 (M.P. 69.73)

T. I. N., T. I. S.,
R. I. W., W. M.

OREGON TRANSPORTATION COMMISSION

Stuart Foster	CHAIRMAN
Gail L. Achterman	COMMISSIONER
Mike Nelson	COMMISSIONER
Randall Papé	COMMISSIONER
Jahn Russell	COMMISSIONER
Bruce A. Warner	DIRECTOR OF TRANSPORTATION

REGISTERED PROFESSIONAL ENGINEER
13,704
Catherine M. Nelson
OREGON
JULY 16, 1987
CATHERINE M. NELSON
Expires Dec. 31, 2004

Catherine M. Nelson
TECHNICAL SERVICES MANAGING ENGINEER

**US26: CORNELL RD. -
OR217 (BEAVERTON) SEC.
SUNSET HIGHWAY
WASHINGTON COUNTY**

FEDERAL HIGHWAY ADMINISTRATION	PROJECT NUMBER	SHEET NO.
OREGON DIVISION	NH-OTIA-S047(052)	1



PE000656/C0341403-011

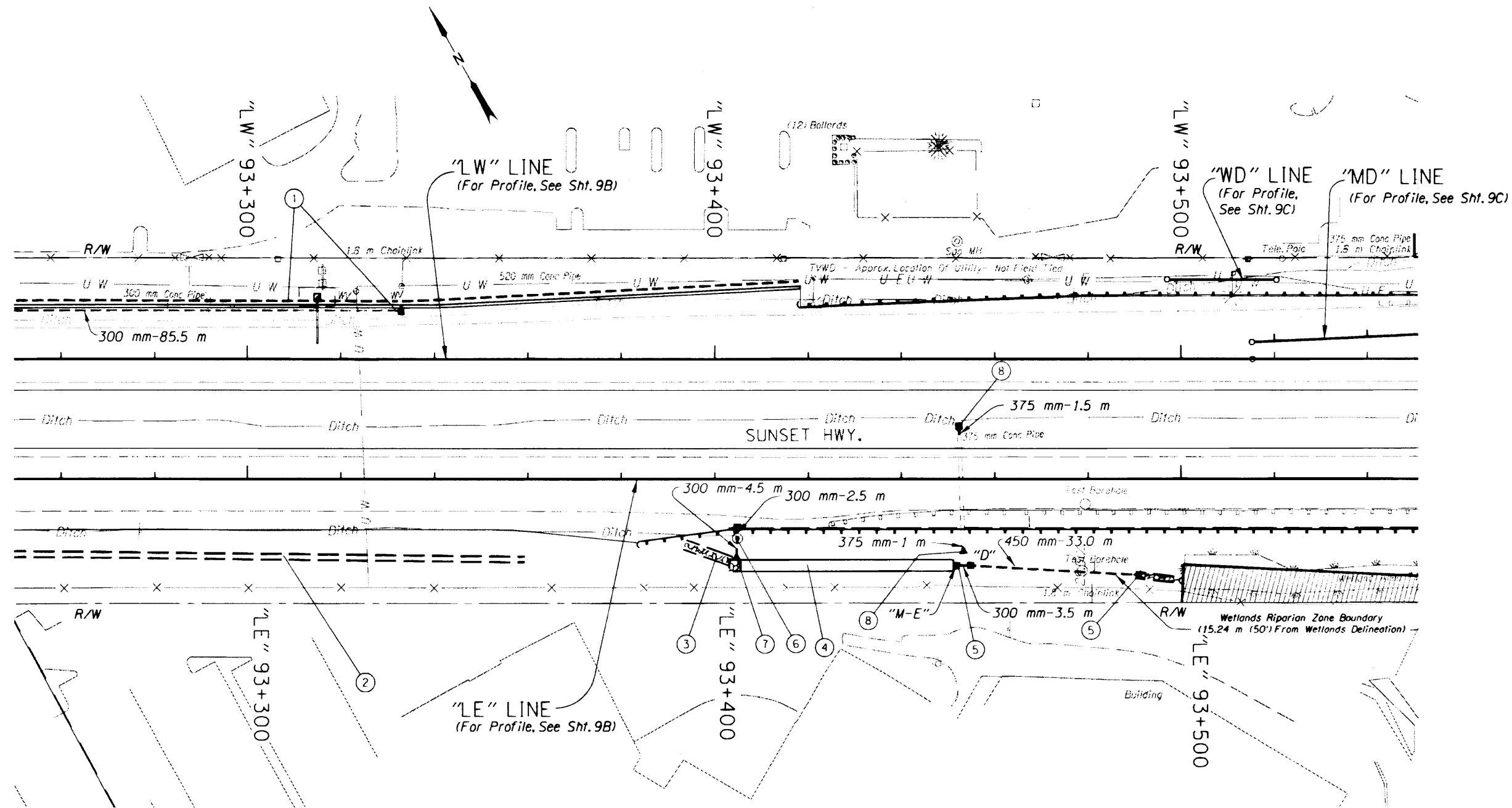

- ① See Sht. 8A, Note 9
- ② See Sht. 8A, Note 8
- ③ Sta. "LE" 93+407.591, 14.824 m Rt.
Const. Ditch
1.2 m Flat Bottom, 1:3 Slopes
Const. Loose Riprap (Class 25) - 44 MG
Riprap Geotextile Matl. Type "1" - 70 M²
Dt. Exc. - 28 M³
(For Details, See Sht. GHJ-8)
- ④ Const. Water Quality Swale "WC3A"
(For Details, See Shts. R-28 & GHJ-39)
- ⑤ Sta. "LE" 93+491.375, 18.982 m Rt.
Const. Ditch
1.2 m Flat Bottom, 1:3 Slopes
Const. Type "M-E" Detention Mod. Inlet
Const. Type "D" Mod. Inlet
Const. Paved End Slope - 5 m²
Const. Loose Riprap (Class 25) - 44 MG
Inst. 300 mm Storm Sew. Pipe - 3.5 m
1.5 m Depth
Inst. 450 mm Storm Sew. Pipe - 33.0 m
1.5 m Depth
Riprap Geotextile Matl. Type "1" - 70 m²
Dt. Exc. - 28 m³
(For Details, See Sht. GHJ-8)
- ⑥ Sta. "LE" 93+404.814, 12.65 m Rt.
Const. Pollution Control Manhole
Const. Type "G-2" Open Grade HMAC Inlet
Inst. 300 mm Storm Sew. Pipe - 2.5 m
1.5 m Depth
(For Details, See Sht. GHJ-23)
- ⑦ Sta. "LE" 93+404.544, 17.234 m Rt.
Const. Pave End Slope - 3.1 m²
Inst. 300 mm Storm Sew. Pipe - 4.5 m
1.5 m Depth
- ⑧ Sta. "LE" 93+453.222, 15.345 m Rt.
Const. Type "M-E" Mod. Inlet
Connect To Extg. Pipe
375 mm Extg. Pipe, In Pl.
Extend - 1.5 m, Lt.
1.0 m, Rt.
Const. Paved End Slope - 3.7 m²

Wetland Area No Work Zone, Shown Thus:

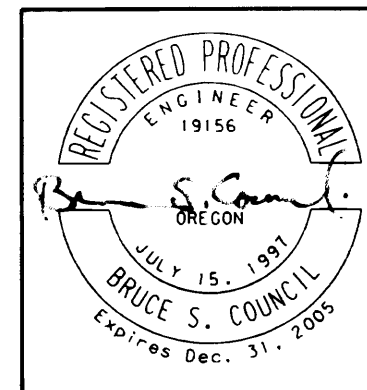

OREGON DEPARTMENT OF TRANSPORTATION ROADWAY ENGINEERING SECTION	
US26: CORNELL RD. - OR217 (BEAVERTON) SEC. SUNSET HIGHWAY WASHINGTON COUNTY	
Design Team Leader - Eileen J. Phelan Designed By - Bruce S. Council Drafted By - Tien Nguyen	
DRAINAGE & UTILITIES	SHEET NO. 9A

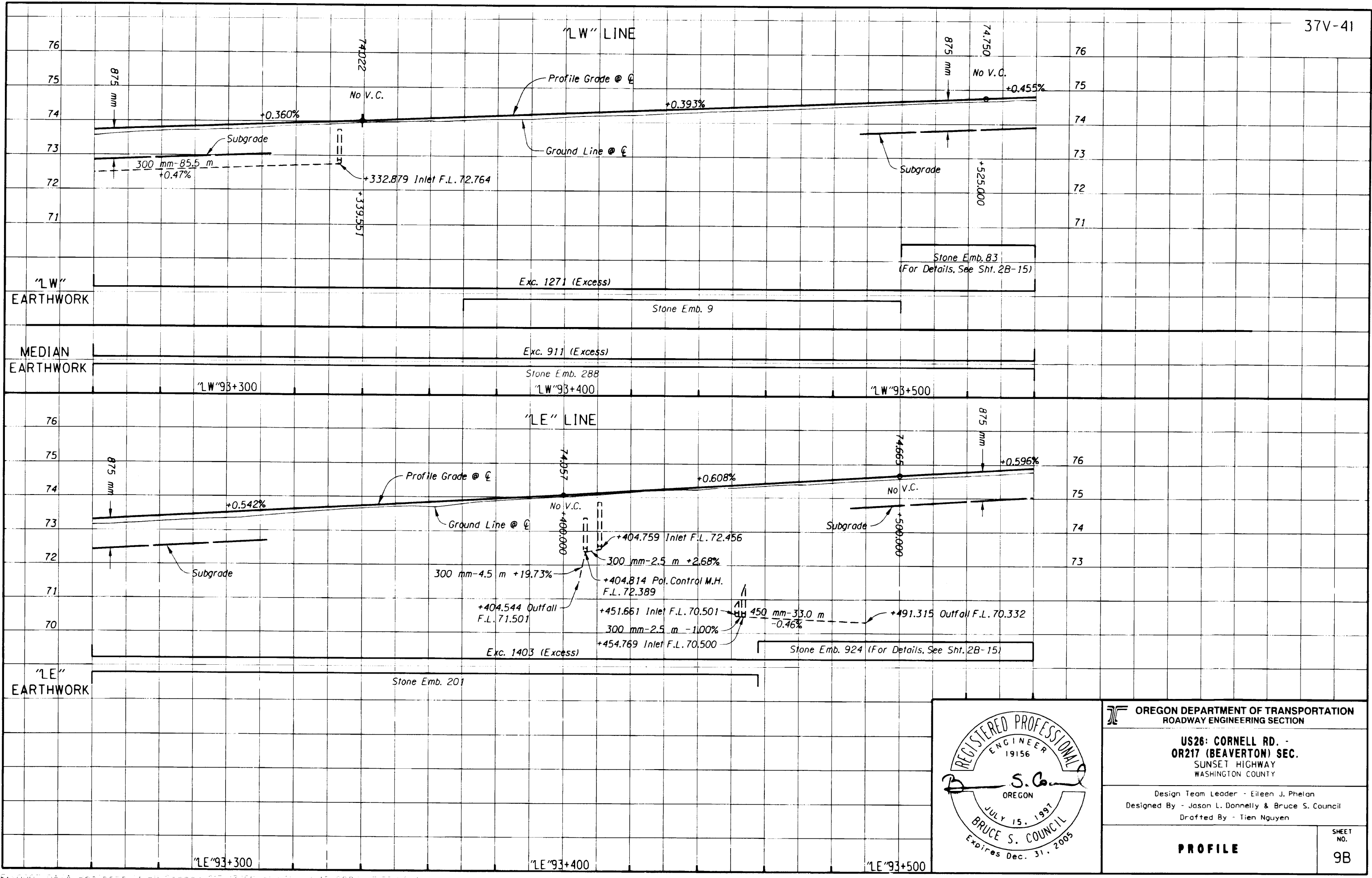

OREGON DEPARTMENT OF TRANSPORTATION
ROADWAY ENGINEERING SECTION

US26: CORNELL RD. -
OR217 (BEAVERTON) SEC.
SUNSET HIGHWAY
WASHINGTON COUNTY

Design Team Leader - Eileen J. Phelan
Designed By - Jason L. Donnelly & Bruce S. Council
Drafted By - Tien Nguyen

PROFILE

SHEET NO. **9B**

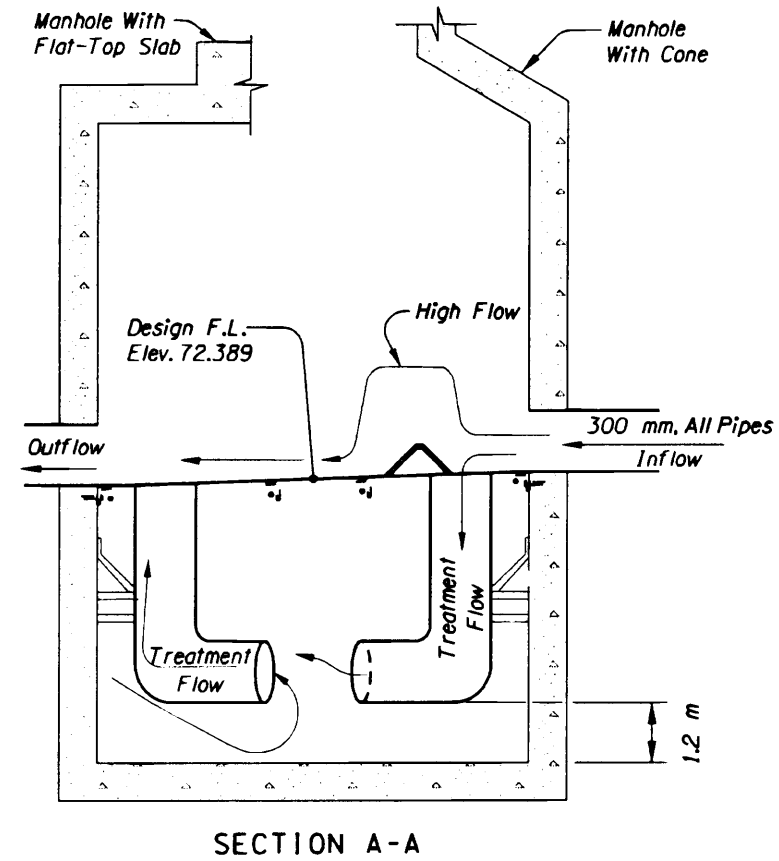
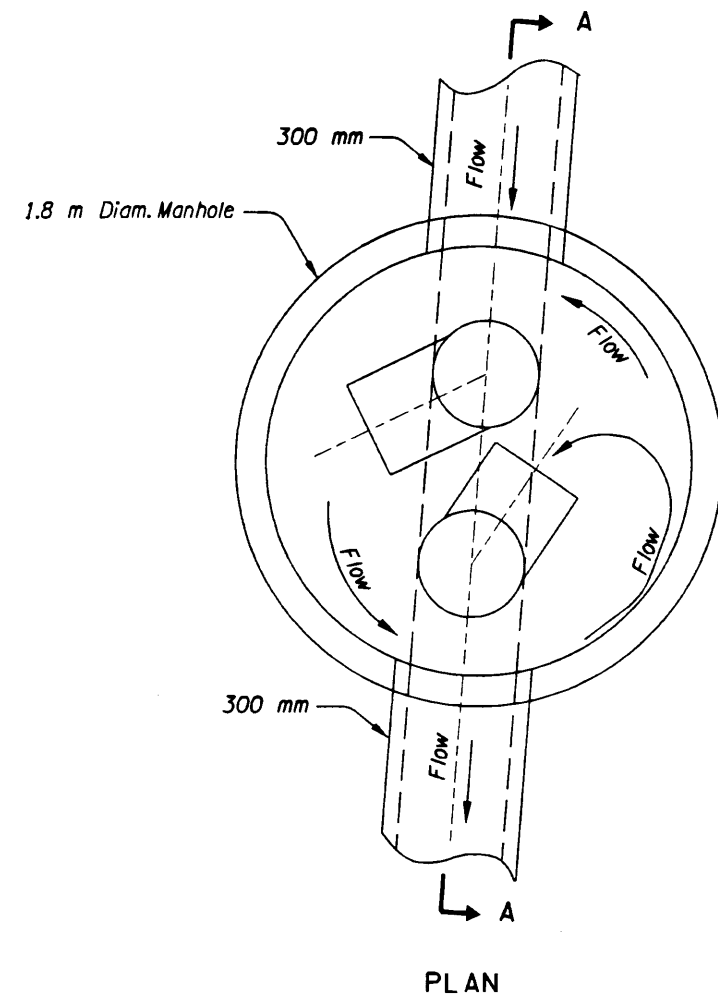

For Details Not Shown, See Sht. GHJ-31
 POLLUTION CONTROL MANHOLE
 Sta. "LE"93+404.86, Rt.

All Dimensions Are In Millimeters (mm)
 Unless Otherwise Noted.

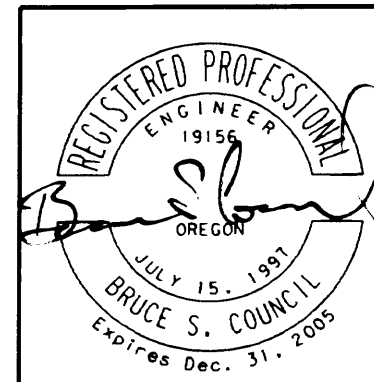

OREGON DEPARTMENT OF TRANSPORTATION GEO / HYDRO SECTION	
US26: CORNELL RD. - OR217 (BEAVERTON) SEC. SUNSET HIGHWAY WASHINGTON COUNTY	
Project Leader - Naveen Chandra Designed By - Bruce S. Council Drafted By - Martin G. Casillas	
WATER QUALITY DETAILS	SHEET NO. GHJ-24

THIS IS THE FILE NAME LOCATION \\screg\mybboc\LUU1\JAI AND\PROJECTS\SUB\Z1\WQ\WQ\WQ\GHJ24

