

det4237.dgn 30-01-2007

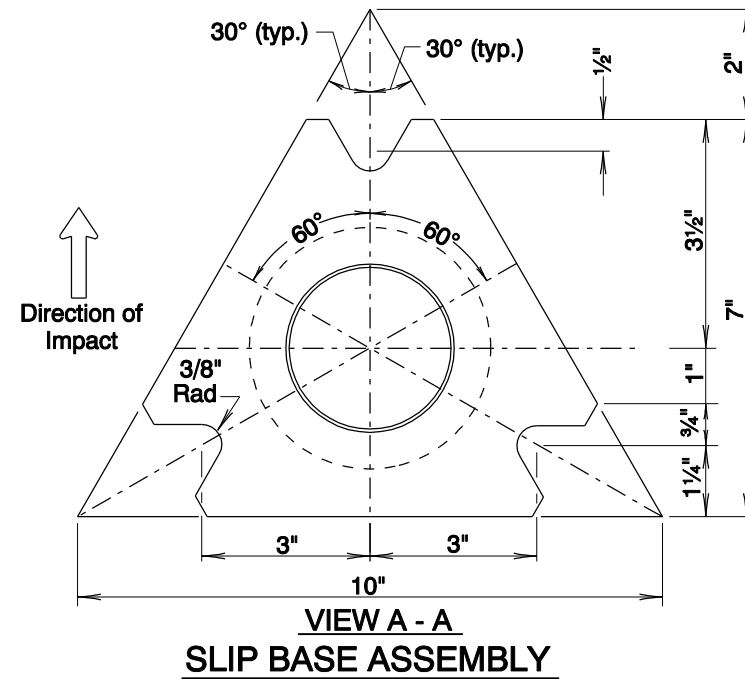
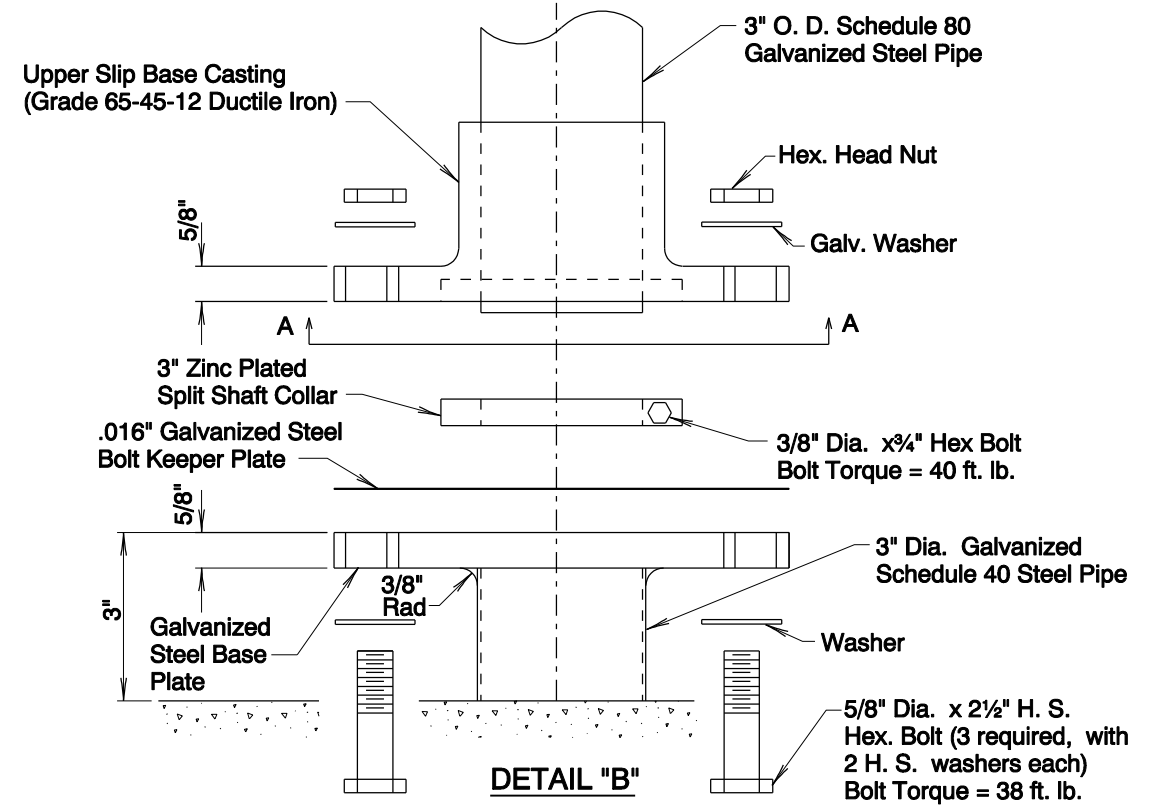
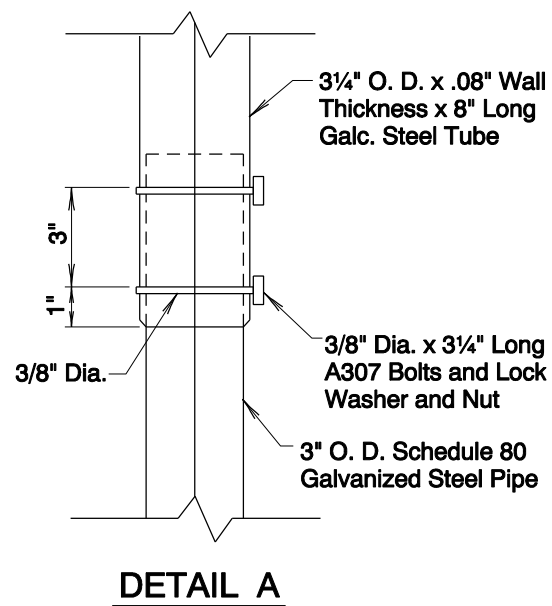
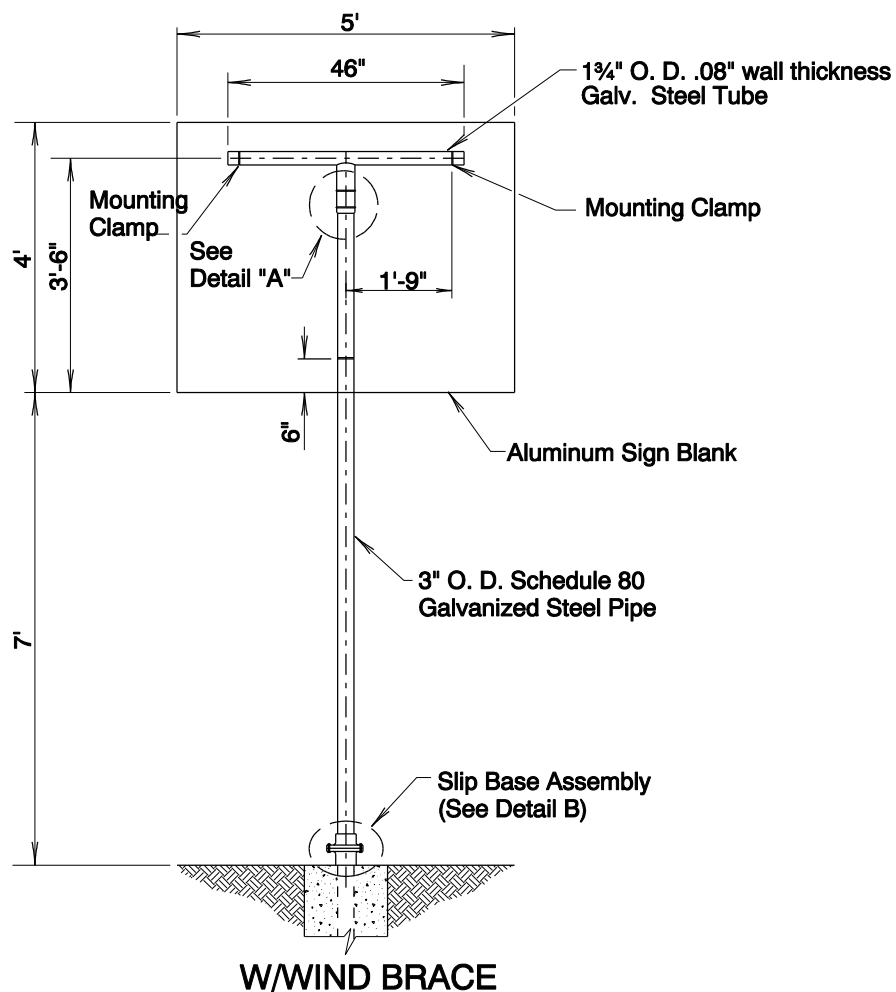
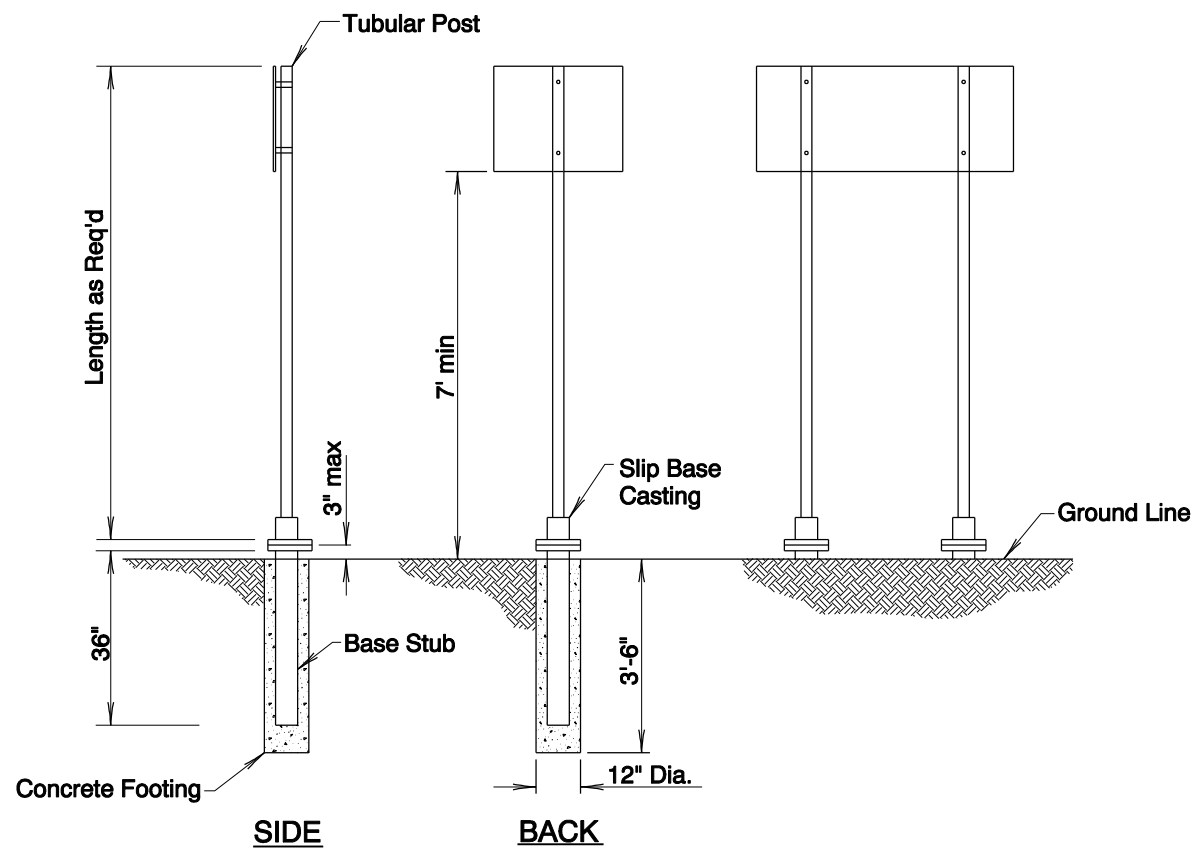

All Bolts, Nuts, and Washers shall be stainless steel ASTM A325 or A449. Option: Galvanized to ASTM A454.

NOT FOR USE ON STATE HIGHWAY SYSTEM

The selection and use of this detail, while designed in accordance with generally accepted engineering principles and practices, is the sole responsibility of the user and should not be used without consulting a Registered Professional Engineer.

OREGON DEPARTMENT OF TRANSPORTATION
TECHNICAL SERVICES
DETAILS

SPECIAL PIPE SIGN SUPPORT

DETAIL NO.

DET4237

DET4237

W/WIND BRACE