

CROSSWALK CLOSURE SUPPORT DETAIL

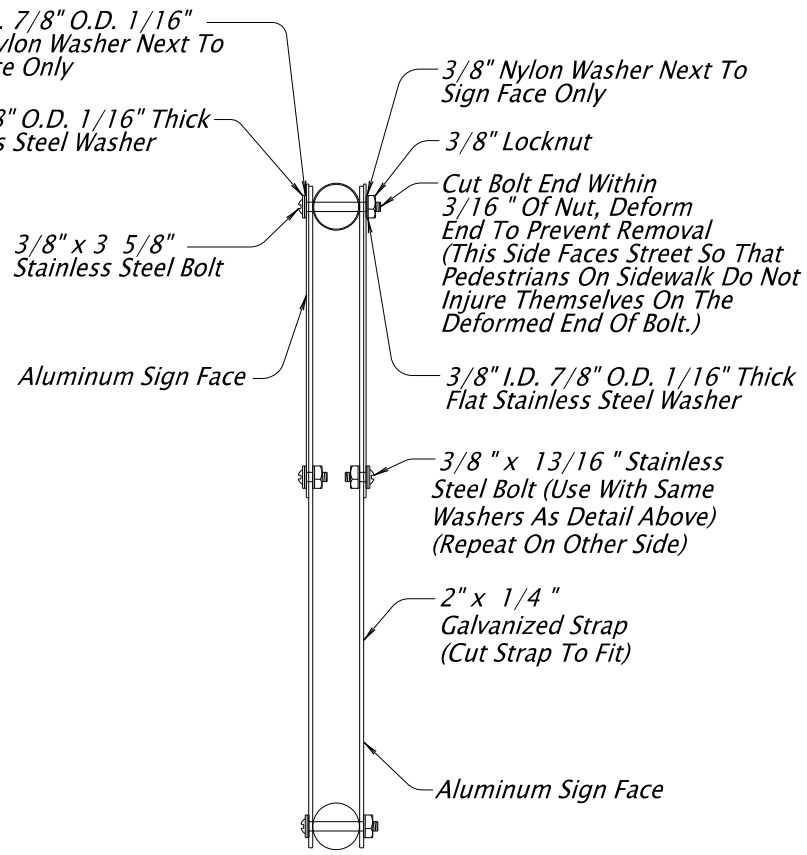

SECTION A-A

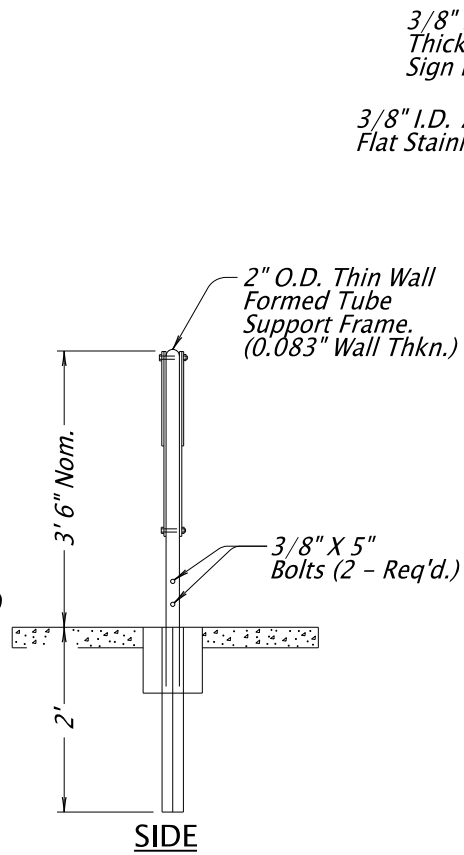

SIGN DETAIL
OR22-7
24" x 18"

Drill 3/8" Dia. Bolt Hole At Each Corner Where Needed.

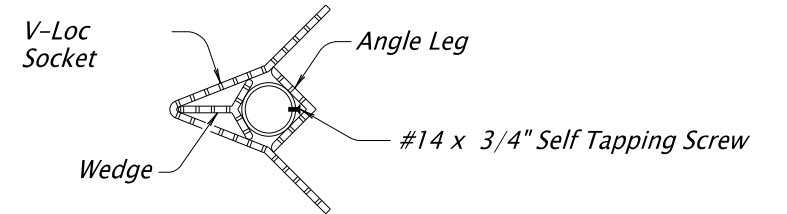

POST MOUNTING SOCKET

For Additional Details See Standard Drg. No. RD100

NOTE:
Care Shall Be Taken That No Concrete Is Placed Within Mounting Socket.

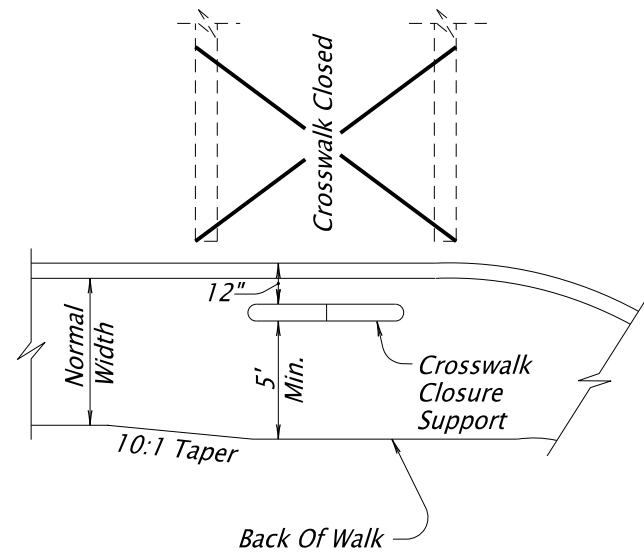

PLAN VIEW

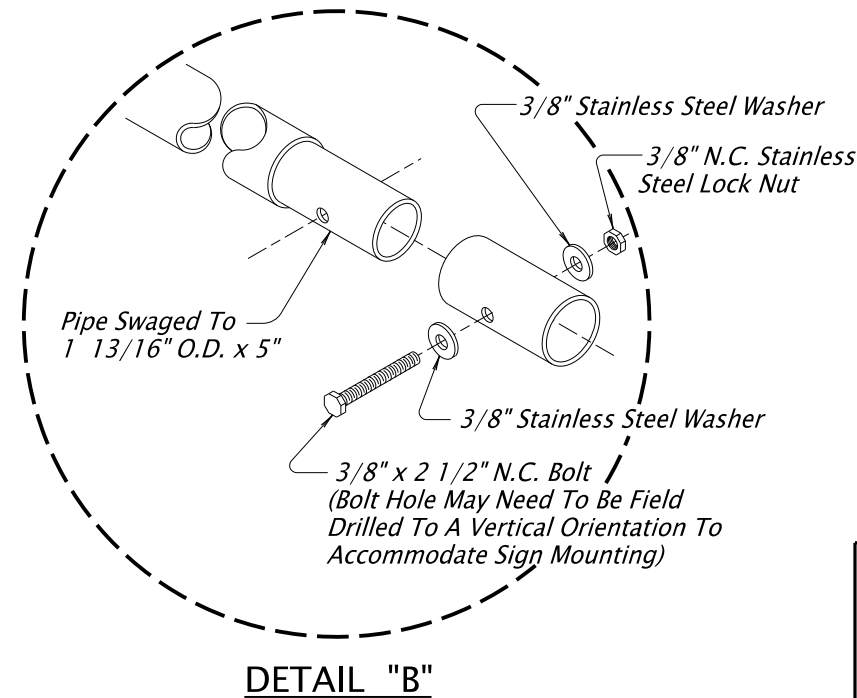

DETAIL "B"

GENERAL NOTES:

1. All Holes In The Tube Support Frame To Be Predrilled By The Manufacturer. (1/32" Larger Than Mounting Bolt)
2. Pipe Swaged By The Manufacturer.

The selection and use of this Standard Drawing, while designed in accordance with generally accepted engineering principles and practices, is the sole responsibility of the user and should not be used without first consulting a Registered Professional Engineer.

All materials shall be in accordance with the current Oregon Standard Specifications.

OREGON STANDARD DRAWINGS

CROSSWALK CLOSURE DETAIL

2021

DATE	REVISION	DESCRIPTION

CALC. BOOK NO. - - -	N/A - - -	SDR DATE - 02-JUL-2018 -	TM240
----------------------	-----------	--------------------------	--------------